

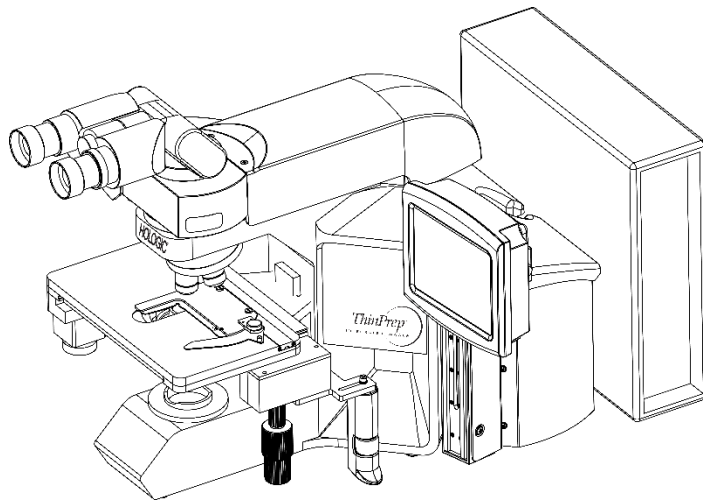

Operation Summary and Clinical Information



The ThinPrep® Integrated Imager

A. INTENDED USE

The Hologic ThinPrep® Integrated Imager is a device that uses computer imaging technology to assist in primary cervical cancer screening of ThinPrep® Pap Test slides for the presence of atypical cells, cervical neoplasia, including its precursor lesions (Low Grade Squamous Intraepithelial Lesions, High Grade Squamous Intraepithelial Lesions), and carcinoma as well as all other cytologic criteria as defined by the Bethesda System: Terminology for Reporting Results of Cervical Cytology¹.

B. SUMMARY AND EXPLANATION OF THE SYSTEM

The ThinPrep Integrated Imager is an automated imaging and review system for use with ThinPrep Pap Test slides. It combines imaging technology to identify microscopic fields of diagnostic interest with automated stage movement of a microscope in order to locate these fields. In routine use, the ThinPrep Integrated Imager selects 22 fields of view for a cytotechnologist to review. Following review of these fields, the cytotechnologist will either complete the diagnosis if no abnormalities are identified or review the entire slide if any abnormalities are identified. The ThinPrep Integrated Imager also allows the physical marking of locations of interest for the cytopathologist.

C. PRINCIPLES OF OPERATION

The ThinPrep Integrated Imager is a combined system which uses computerized image analysis and automated microscope location to assist a cytotechnologist or pathologist to identify areas of a slide that are of most interest. Slides used with this system must first be prepared on the ThinPrep® 2000 System or ThinPrep® 5000 processors, and stained with ThinPrep® Stain. The ThinPrep Integrated Imager can be used as a conventional microscope when not used for ThinPrep® imaging.

The ThinPrep Integrated Imager images the entire cell spot of the slide in approximately 90 seconds. The system acquires and processes image data from the slides to identify diagnostically relevant cells or cell groups based on an imaging algorithm that considers cellular features and nuclear darkness. During slide imaging, the alphanumeric slide accession identifier is recorded and the *x* and *y* coordinates of 22 fields of interest are stored in the system.

After image processing, the device acts as an automated microscope, presenting the 22 fields containing the cells of interest to the cytotechnologist for review. The cytotechnologist uses the review control or touch screen to step through each of the fields of interest (Autolocate). Additionally, the Review Scope provides a method for automated marking of objects for further review. If the cytotechnologist identifies any of these fields as containing abnormal objects, that field may be marked electronically. The Integrated Imager will guide the cytotechnologist to conduct a review of the entire cell spot for any slide that has had fields electronically marked (Autoscan).

The Cytotechnologist determines specimen adequacy and the presence of infections during the review of the 22 fields of view presented by the ThinPrep Integrated Imager. Either of two methods can be used to determine specimen adequacy. The first method is to count cells and determine the average number of cells in the 22 fields of view presented by the Imager. The second method is to count and determine the average number of cells in 10 fields of view across the diameter of the cell spot. Either method will enable the cytotechnologist to determine if the

minimum cells, as recommended by Bethesda System criteria, are present on the slide. At the conclusion of the slide review, electronically marked objects are manually marked on the slide by the cytotechnologist. Slide information is stored in the computer database including the *x* and *y* coordinates representing the electronically marked locations, and the status of the slide is designated as “complete”.

The cytotechnologist can review the slides immediately after each slide is imaged (sequential modality) or, as an alternative workflow for labs, slides can be imaged in succession, and coordinates stored in the computer database for later cytotechnologist or pathologist review (batched modality).

D. LIMITATIONS

- Only personnel who have been appropriately trained should operate the ThinPrep Integrated Imager.
- All slides that undergo primary automated screening with the Integrated Imager require manual rescreening of the selected fields of view by a cytotechnologist or pathologist.
- The ThinPrep Integrated Imager is only indicated for use with the ThinPrep Pap Test.
- The ThinPrep Integrated Imager is only indicated for the ThinPrep Pap Test slides prepared with the ThinPrep[®] 2000 System and the ThinPrep[®] 5000 processor. The ThinPrep Integrated Imager is not indicated for the ThinPrep Pap Test slides prepared with the ThinPrep[®] 3000 processor.
- ThinPrep[®] slides with fiducial marks must be used.
- Slides must be stained using the ThinPrep Stain according to the applicable ThinPrep Integrated Imager slide staining protocol.
- Slides should be clean and free of debris before being placed on the system.
- The slide coverslip should be dry and located correctly.
- Slides that are broken or poorly coverslipped should not be used.
- Slides used with the ThinPrep Integrated Imager must contain properly formatted accession number identification information as described in the operator’s manual.
- Slides once successfully imaged on the Integrated Imager cannot be imaged again.
- The performance of the ThinPrep Integrated Imager using slides prepared from reprocessed sample vials has not been evaluated; therefore it is recommended that these slides be manually reviewed.

E. WARNINGS

- The Integrated Imager generates, uses, and can radiate radio frequency energy and may cause interference to radio communications.
- A Hologic authorized service representative must install the ThinPrep Integrated Imager.

F. PRECAUTIONS

- Caution should be used when loading and unloading glass slides on the ThinPrep Integrated Imager to prevent slide breakage and/or injury.
- The Integrated Imager should be placed on a flat, sturdy surface away from any vibrating machinery to assure proper operation.

G. PERFORMANCE CHARACTERISTICS

The ThinPrep Integrated Imager is technologically similar to the ThinPrep Imaging System. The performance characteristics of the ThinPrep Integrated Imager were compared to the ThinPrep Imaging System in a multi-center clinical study. The ThinPrep® Imaging System was compared to Manual Review in a separate multi-center clinical study. Both clinical studies are described in the following sections.

G.1 ThinPrep Imaging System Compared to Manual Review

A multi-center, two-armed clinical study was performed over an eleven (11) month period at four (4) cytology laboratory sites within the United States². The objective of the study entitled “Multi-Center Trial Evaluating the Primary Screening Capability of the ThinPrep® Imaging System” was to show that routine screening of ThinPrep Pap Test slides using the ThinPrep Imaging System is equivalent to a manual review of ThinPrep slides for all categories used for cytologic diagnosis (specimen adequacy and descriptive diagnosis) as defined by the Bethesda System criteria¹.

The two-arm study approach allowed for a comparison of the cytologic interpretation (descriptive diagnosis and specimen adequacy) from a single ThinPrep-prepared slide, screened first using standard laboratory cervical cytology practices (*Manual Review*) and then after a 48-day time lag were screened with the assistance of the ThinPrep Imaging System (*Imager Review*). A subset of slides from the study were reviewed and adjudicated by a panel of three (3) independent cytopathologists to determine a consensus diagnosis. The consensus diagnosis was used as a “gold standard” for truth to evaluate the results of the study.

G.1.1 Laboratory and Patient Characteristics

Of the 10,359 subjects in the study, 9,550 met the requirements for inclusion in the descriptive diagnosis analysis. During the study, 7.1% (732/10,359) slides could not be read on the Imager and required a manual review during the *Imager Review* arm. Excessive number of air bubbles on the slides was the leading contributor. Additional factors included focus problems, slide density, slide identification read failures, slides detected out of position, multiple slides seated within a cassette slot and slides that had already been imaged. The cytology laboratories participating in the study were comprised of four centers. All sites selected had extensive experience in the processing and evaluation of gynecologic ThinPrep slides, and were trained in the use of the ThinPrep Imaging System. The study population represented diverse geographic regions and subject populations of women who would undergo cervical screening with the ThinPrep Imaging System in normal clinical use. These sites included both women being routinely screened (screening population) and patients with a recent previous cervical abnormality (referral population). The characteristics of the study sites are summarized in Table 1.

Table 1. Site Characteristics

| Site | 1 | 2 | 3 | 4 |
|---|----------|----------|----------|----------|
| Screening (Low Risk) Population | 88% | 82% | 90% | 94% |
| Referral (High Risk) Population | 12% | 18% | 10% | 6% |
| HSIL+ prevalence | 1.1% | 0.7% | 0.4% | 0.6% |
| ThinPrep Pap Tests Per Year | 120,000 | 70,200 | 280,000 | 105,000 |
| Number of Cytotechnologists | 14 | 9 | 32 | 11 |
| Number of Cytotechnologists in Study | 2 | 2 | 2 | 2 |
| Number of Cytopathologists | 6 | 5 | 6 | 14 |
| Number of Cytopathologists in Study | 1 | 2 | 1 | 2 |

G.1.2 Descriptive Diagnosis Sensitivity and Specificity Estimates

A panel of three independent cytopathologists adjudicated slides from all discordant (one-grade or higher cytologic difference) descriptive diagnosis cases (639), all concordant positive cases (355) and a random 5% subset of the 8550 negative concordant cases (428). The cytopathologists on the adjudication panel were board-certified, all of whom had a subspecialty certification in cytopathology. Their experience levels in cytopathology ranged from 6 to 12 years. Two of the adjudicators were from university practices and one adjudicator was from a private medical center. The volumes for the adjudicator’s institutions ranged from 12,000 to 30,000 ThinPrep Pap Tests annually.

A consensus diagnosis was defined as agreement by at least 2 of 3 cytopathologists. All slides sent to the panel of cytopathologists were not identified by site nor ordered in any fashion. When a consensus diagnosis could not be obtained by at least 2 of 3 cytopathologists, the full panel of cytopathologists reviewed each case simultaneously using a multi-headed microscope to determine a consensus diagnosis.

The adjudicated results were used as a “gold standard” to define the following major “true” descriptive diagnosis classifications of the Bethesda System: Negative, ASCUS, AGUS, LSIL, HSIL, Squamous Cell Carcinoma (SQ CA) and Glandular Cell Carcinoma (GL CA). Estimates of sensitivity and specificity together with 95% confidence intervals were calculated for the *Manual Review* and *Imager Review* arms of the study. The differences in sensitivity and specificity between the two arms, together with their 95% confidence intervals were also calculated. Among the random 5% subset of 8,550 cases (428 slides) that were found to be negative by both arms and adjudicated, there were 425 “true” negative and 3 “true” ASCUS slides. A multiple imputation technique was used to adjust the numbers of true positives and true negatives for the 8,550 negative concordant cases based on the 5% of cases that were adjudicated².

Table 2 summarizes the descriptive diagnosis sensitivity and specificity estimates with 95% confidence intervals for all sites combined for “true” ASCUS+, LSIL+ and HSIL+.

Table 2. Manual Review Versus Imager Review, Descriptive Diagnosis Summary

| Threshold | Sensitivity | | | Specificity | | |
|-----------|---------------------------|---------------------------|----------------------------|---------------------------|---------------------------|---------------------------|
| | Manual (95% CI) | Imager (95% CI) | Difference (95% CI) | Manual (95% CI) | Imager (95% CI) | Difference (95% CI) |
| ASCUS+ | 75.6% (72.2% to 78.8%) | 82.0% (78.8% to 84.8%) | +6.4% (2.6% to 10.0%) | 97.6% (97.2% to 97.9%) | 97.8% (97.4% to 98.1%) | +0.2% (-0.2% to 0.6%) |
| LSIL+ | 79.7% (75.3% to 83.7%) | 79.2% (74.7% to 83.2%) | -0.5% (-5.0% to 4.0%) | 99.0% (98.8% to 99.2%) | 99.1% (98.9% to 99.3%) | +0.09% (-0.1% to 0.3%) |
| HSIL+ | 74.1% (66.0% to 81.2%) | 79.9% (72.2% to 86.2%) | +5.8% (-1.1% to 12.6%) | 99.4% (99.2% to 99.6%) | 99.6% (99.5% to 99.7%) | +0.2% (0.06% to 0.4%) |
| UNSAT | 29.3% (18.1% to 42.7%) | 13.8% (6.1% to 25.4%) | -15.5% (-25.9% to 5.0%) | 99.5% (99.3% to 99.6%) | 99.8% (99.7% to 99.9%) | +0.3% (0.2% to 0.4%) |

The results presented in Table 2 show that for ASCUS+, the increase in sensitivity of the *Imager Review* over the *Manual Review* was statistically significant with the lower limit of the 95% confidence interval being 2.6% for all sites combined. The observed difference between sensitivities for ASCUS+ varied among the sites from -2.8% with a 95% confidence interval of (-10.6%; 5.0%) to +14.4% with a 95% confidence interval of (8.2%; 20.5%). The difference in specificity results between the *Imager Review* and the *Manual Review* was not statistically significant with a 95% confidence interval of -0.2% to +0.6%. The observed differences between specificities varied among the sites from -0.3% to +0.4%.

The results presented in Table 2 show that the difference between sensitivities of the *Imager Review* and *Manual Review* arms for LSIL+ for all sites combined was not statistically significant with a 95% confidence interval of -5.0% to +4.0%. The observed difference between sensitivities for LSIL+ varied among the sites from -6.3% with a 95% confidence interval of (-14.7%; 2.1%) to +8.1% with a 95% confidence interval of (-4.0%; 20.1%). The difference in specificity results between the *Imager Review* and the *Manual Review* was not statistically significant with a 95% confidence interval of -0.1% to +0.3%. The observed differences between specificities varied among the sites from -0.4% to +0.6%.

The results presented in Table 2 show that the difference between sensitivities of the *Imager Review* and *Manual Review* arms for HSIL+ for all sites combined was not statistically significant with a 95% confidence interval of -1.1% to +12.6%. The observed difference between sensitivities for HSIL+ varied among the sites from -2.5% with a 95% confidence interval of (-15.4%; 10.4%) to +13.6% with a 95% confidence interval of (-0.7%; 28.0%). The increase in specificity of the *Imager Review* over the *Manual Review* was statistically significant with a 95% confidence interval of +0.06% to +0.4%. The observed differences between specificities varied among the sites from -0.1% to +0.7%.

Table 3 shows the unadjudicated marginal frequencies data for benign cellular changes for all sites combined.

Table 3. Unadjudicated Marginal Frequencies - Summary of Descriptive Diagnosis for Benign Cellular Changes – All Sites Combined.

| Number of Patients: | Manual Review | | Imager Review | |
|---|---------------|------------|---------------|------------|
| | 9550 | | | |
| Descriptive Diagnosis | N | % | N | % |
| Benign Cellular Changes: | 405 | 4.2 | 293 | 3.1 |
| Infection: | | | | |
| Trichomonas Vaginalis | 8 | 0.1 | 8 | 0.1 |
| Fungal organisms consistent with Candida spp. | 47 | 0.5 | 31 | 0.3 |
| Predominance of coccobacilli | 71 | 0.7 | 60 | 0.6 |
| Bacteria consistent with Actinomyces spp. | 1 | 0.0 | 1 | 0.0 |
| Cellular Changes associated with Herpes virus | 1 | 0.0 | 1 | 0.0 |
| Other Infection | 1 | 0.0 | 0 | 0.0 |
| Reactive Cellular Changes Associated with: | | | | |
| Inflammation | 218 | 2.3 | 156 | 1.6 |
| Atrophic with inflammation (atrophic vaginitis) | 68 | 0.7 | 46 | 0.5 |
| Radiation | 0 | 0.0 | 0 | 0.0 |
| Intrauterine contraceptive device (IUD) | 0 | 0.0 | 0 | 0.0 |
| Other Reactive Cellular Change | 34 | 0.4 | 14 | 0.1 |

Note: Some patients had more than one diagnostic subcategory.

The Manual Review showed a higher rate of Benign Cellular Changes (405) than the Imager Review cases (293).

Please refer to the Instructions for Use for ThinPrep® Imaging System (MAN-04199-001) for detailed information about the performance of ThinPrep Imaging System.

G.2 ThinPrep Integrated Imager Compared to the ThinPrep Imaging System

A multi-center, two-armed clinical study was performed at three (3) sites within the United States. The objective of the study entitled “Multi-Center Evaluation of the ThinPrep® Integrated Imager” was to show that routine screening of ThinPrep Pap Test slides prepared on the ThinPrep® 2000 System and the ThinPrep® 5000 processor using the ThinPrep Integrated Imager is similar to the review of ThinPrep slides using the ThinPrep Imaging System for all categories used for cytologic diagnosis (specimen adequacy and descriptive diagnosis) as defined by the Bethesda System criteria¹.

The two-arm study approach allowed for a comparison of the cytologic interpretation (descriptive diagnosis and specimen adequacy) from a single ThinPrep-prepared slide (of known diagnosis), screened first using the Integrated Imager and then after two-week lag were screened with the assistance of the ThinPrep Imaging System. The adjudicated diagnosis at enrollment was used as a “gold standard” for truth to evaluate the results of the study.

Slides utilized in this study were processed on the ThinPrep® 2000 System and the ThinPrep® 5000 processor. Study slides were produced, reviewed manually and adjudicated during the execution of a previous study².

All slides were reviewed independently for both study arms. The slides were randomized prior to slide review in each study arm. Cytological diagnoses and specimen adequacy were determined in accordance with the Bethesda System criteria for both arms of the study.

G.2.1 Laboratory and Patient Characteristics

The cytology laboratories participating in the study were comprised of three (3) centers. All sites selected had extensive experience in the processing and evaluation of gynecologic ThinPrep slides, and were trained in the use of the ThinPrep Integrated Imager.

Number of patients (planned and analyzed):

2520 slides (840 each site) were enrolled in this study. Six (6) out of 2520 (0.2%) slides were excluded from review and analysis as they were broken and unreadable.

Basic demographic information was collected for each slide enrolled at each site to aid the cytotechnologist in making a diagnosis for the resulting slides. A summary of this demographic information is presented in Table 4 for all sites.

Table 4. Site Demographics

| Site Number | Age (yrs) Median | # Hysterectomy (% of enrolled) | # Postmenopausal (% of enrolled) |
|-------------|------------------|--------------------------------|----------------------------------|
| 1 | 36 yrs | 11 (2.6%) | 30 (7.1%) |
| 2 | 33 yrs | 15 (3.6%) | 25 (6.0%) |
| 3 | 37 yrs | 25 (6.0%) | 51 (12.1%) |
| Overall | 35 yrs | 51 (4.0%) | 106 (8.4%) |

Each slide was reviewed independently three (3) times at each site, by three (3) separate pairs of cytotechnologists and pathologists using normal laboratory and clinical procedures. This produced a total of 7542 diagnostic results. None of these results were excluded from analysis.

Main Eligibility Criteria

Inclusion Criteria

Study slides (two slides per case, one slide was prepared on the ThinPrep 2000 System and another slide was prepared on the ThinPrep 5000 processor) were produced, reviewed manually and adjudicated during the execution of a previous study². The ThinPrep Pap Test slides from three sites included the following:

- NILM: 1260 slides from 630 cases
- ASC-US: 300 slides from 150 cases
- LSIL: 300 slides from 150 cases
- ASC-H: 300 slides from 150 cases
- AGUS: 30 slides from 15 cases
- HSIL: 300 slides from 150 cases
- Cancers: 30 slides from 15 cases

Exclusion Criteria

Slide broken or rendered unreadable for the purposes of this study.

Criteria for Evaluation

The primary objective of this study was to estimate the sensitivity, specificity, and likelihood ratios when diagnosing slides imaged and reviewed on the Integrated Imager (sequential

modality) and to compare with the ThinPrep Imaging System (TIS). The reference standard for the slides in this study was pathologist adjudication consensus diagnosis from a previous study².

G.2.2 Descriptive Diagnosis Sensitivity and Specificity Estimates

Abbreviations for Diagnostic Thresholds:

Category Partitions

| Threshold | Negative | Positive |
|-----------|--------------------------------|--|
| ASCUS+ | NILM | ASCUS, LSIL, ASC-H, AGUS, HSIL, Cancer |
| LSIL+ | NILM, ASCUS | LSIL, ASC-H, AGUS, HSIL, Cancer |
| ASC-H+ | NILM, ASCUS, LSIL | ASC-H, AGUS, HSIL, Cancer |
| HSIL+ | NILM, ASCUS, LSIL, ASC-H, AGUS | HSIL, Cancer |

The study results are presented in Table 5. In all abnormal categories, the sensitivity for the Integrated Imager was higher than the ThinPrep Imaging System across all thresholds listed in Table 5. There was a slight decrease in specificity for the Integrated Imager as compared to the ThinPrep Imaging System.

Table 5. ThinPrep Imaging System (TIS) Versus Integrated Imager, Descriptive Diagnosis Summary (All Slides)

| Threshold | Sensitivity | | | Specificity | | |
|-----------|---------------------------|----------------------------|--------------------------|---------------------------|----------------------------|---------------------------|
| | TIS (95% CI) | Integrated Imager (95% CI) | Difference (95% CI) | TIS (95% CI) | Integrated Imager (95% CI) | Difference (95% CI) |
| ASCUS+ | 86.0% (84.7% to 87.3%) | 89.8% (88.6% to 90.9%) | 3.8% (2.6% to 5.0%) | 89.8% (88.9% to 90.6%) | 87.9% (86.9% to 88.8%) | -1.9% (-2.8% to -1.0%) |
| LSIL+ | 77.8% (76.0% to 79.6%) | 83.7% (82.0% to 85.2%) | 5.8% (4.1% to 7.5%) | 92.5% (91.7% to 93.2%) | 90.6% (89.8% to 91.4%) | -1.9% (-2.6% to -1.2%) |
| ASC-H+ | 73.3% (70.4% to 75.9%) | 80.7% (78.1% to 83.0%) | 7.4% (4.7% to 10.1%) | 92.7% (92.0% to 93.3%) | 91.1% (90.4% to 91.8%) | -1.6% (-2.1% to -1.0%) |
| HSIL+ | 59.6% (55.9% to 63.3%) | 67.5% (63.9% to 70.9%) | 7.9% (4.5% to 11.2%) | 95.1% (94.6% to 95.6%) | 94.0% (93.4% to 94.6%) | -1.1% (-1.6% to -0.6%) |
| UNSAT | 78.9% (71.6% to 84.7%) | 77.6% (70.2% to 83.5%) | -1.4% (-7.3% to 4.5%) | 98.4% (98.1% to 98.6%) | 98.4% (98.1% to 98.7%) | 0.1% (-0.2% to 0.3%) |

In addition, the data is presented below stratified by the type of processor used (ThinPrep 2000 System and ThinPrep 5000 processor). In all abnormal cases, the sensitivity for the Integrated Imager was higher than the ThinPrep Imaging System across all thresholds. There was a slight decrease in specificity for the Integrated Imager as compared to the ThinPrep Imaging System.

**Table 6. ThinPrep Imaging System (TIS) Versus Integrated Imager (I2),
Descriptive Diagnosis Summary (ThinPrep 2000 System-processed slides only)**

| Threshold | Sensitivity | | | Specificity | | |
|---------------|--|--|--|--|--|---|
| | TIS [# of reads] (95% CI) | I2 [# of reads] (95% CI) | Difference [# of reads] (95% CI) | TIS [# of reads] (95% CI) | I2 [# of reads] (95% CI) | Difference [# of reads] (95% CI) |
| ASCUS+ | 85.7% [1209/1411] (83.8% to 87.4%) | 90.0% [1270/1411] (88.3% to 91.5%) | 4.3% [61/1411] (2.6% to 6.1%) | 90.3% [2006/2222] (89.0% to 91.4%) | 88.9% [1975/2222] (87.5% to 90.1%) | -1.4% [-31/2222] (-2.7% to -0.1%) |
| LSIL+ | 77.6% [820/1057] (75.0% to 80.0%) | 84.3% [891/1057] (82.0% to 86.4%) | 6.7% [71/1057] (4.3% to 9.1%) | 92.7% [2388/2576] (91.6% to 93.6%) | 91.3% [2353/2576] (90.2% to 92.4%) | -1.4% [-35/2576] (-2.3% to -0.4%) |
| ASC-H+ | 73.1% [370/506] (69.1% to 76.8%) | 81.8% [414/506] (78.2% to 84.9%) | 8.7% [44/506] (4.9% to 12.5%) | 92.8% [2903/3127] (91.9% to 93.7%) | 91.1% [2849/3127] (90.1% to 92.1%) | -1.7% [-54/3127] (-2.5% to -1.0%) |
| HSIL+ | 59.0% [214/363] (53.8% to 63.9%) | 70.2% [255/363] (65.4% to 74.7%) | 11.3% [41/363] (6.4% to 16.1%) | 95.4% [3118/3270] (94.6% to 96.0%) | 94.2% [3081/3270] (93.4% to 95.0%) | -1.1% [-37/3270] (-1.8% to -0.5%) |
| UNSAT | 83.3% [65/78] (73.5% to 90.0%) | 82.1% [64/78] (72.1% to 89.0%) | -1.3% [1/78] (-8.9% to 6.2%) | 98.6% [3647/3699] (98.2% to 98.9%) | 98.6% [3649/3699] (98.2% to 99.0%) | 0.1% [2/3699] (-0.3% to 0.4%) |

**Table 7. ThinPrep Imaging System (TIS) Versus Integrated Imager (I2),
Descriptive Diagnosis Summary (ThinPrep 5000 Processor-processed slides only)**

| Threshold | Sensitivity | | | Specificity | | |
|---------------|--|--|--|--|--|---|
| | TIS [# of reads] (95% CI) | I2 [# of reads] (95% CI) | Difference [# of reads] (95% CI) | TIS [# of reads] (95% CI) | I2 [# of reads] (95% CI) | Difference [# of reads] (95% CI) |
| ASCUS+ | 86.4% [1190/1377] (84.5% to 88.1%) | 89.6% [1234/1377] (87.9% to 91.1%) | 3.2% [44/1377] (1.6% to 4.8%) | 89.3% [1989/2228] (87.9% to 90.5%) | 86.8% [1935/2228] (85.4% to 88.2%) | -2.4% [-54/2228] (-3.8% to -1.1%) |
| LSIL+ | 78.1% [796/1019] (75.5% to 80.5%) | 83.0% [846/1019] (80.6% to 85.2%) | 4.9% [50/1019] (2.5% to 7.3%) | 92.2% [2385/2586] (91.1% to 93.2%) | 89.9% [2324/2586] (88.6% to 91.0%) | -2.4% [-61/2586] (-3.4% to -1.4%) |
| ASC-H+ | 73.4% [354/482] (69.3% to 77.2%) | 79.5% [383/482] (75.6% to 82.8%) | 6.0% [29/482] (2.2% to 9.8%) | 92.5% [2888/3123] (91.5% to 93.3%) | 91.1% [2845/3123] (90.0% to 92.0%) | -1.4% [-43/3123] (-2.2% to -0.6%) |
| HSIL+ | 60.4% [194/321] (55.0% to 65.6%) | 64.5% [207/321] (59.1% to 69.5%) | 4.0% [13/321] (-0.6% to 8.6%) | 94.9% [3116/3284] (94.1% to 95.6%) | 93.8% [3082/3284] (93.0% to 94.6%) | -1.0% [-34/3284] (-1.7% to -0.3%) |
| UNSAT | 73.9% [51/69] (62.5% to 82.8%) | 72.5% [50/69] (61.0% to 81.6%) | -1.4% [1/69] (-11.3% to 8.4%) | 98.2% [3628/3696] (97.7% to 98.5%) | 98.2% [3630/3696] (97.7% to 98.6%) | 0.1% [2/3696] (-0.3% to 0.4%) |

Tables 8 through 14 show the performance of TIS review and Integrated Imager review compared to adjudicated diagnosis made by the adjudication panel (truth, from previous study) for the following major descriptive diagnosis classifications of the Bethesda System: NILM, ASCUS, LSIL, ASC-H, AGUS, HSIL and Cancer.

**Table 8. “True Negative” (NILM) Contingency Table (for All Sites Combined)
Overall Adjudicated NILM
TIS vs. I2**

| | | TIS | | | | | | | |
|----|--------|-------|------|-------|------|-------|------|------|--------|
| | | UNSAT | NILM | ASCUS | LSIL | ASC-H | AGUS | HSIL | Cancer |
| I2 | UNSAT | 75 | 29 | 2 | 0 | 1 | 1 | 0 | 0 |
| | NILM | 25 | 3735 | 147 | 5 | 13 | 7 | 3 | 0 |
| | ASCUS | 5 | 187 | 123 | 11 | 16 | 1 | 1 | 0 |
| | LSIL | 0 | 21 | 22 | 14 | 2 | 0 | 2 | 0 |
| | ASC-H | 1 | 29 | 20 | 1 | 23 | 1 | 4 | 0 |
| | AGUS | 1 | 15 | 3 | 0 | 0 | 5 | 0 | 0 |
| | HSIL | 0 | 8 | 4 | 0 | 10 | 0 | 10 | 0 |
| | Cancer | 0 | 0 | 2 | 0 | 0 | 1 | 0 | 4 |

**Table 9. “True ASCUS” Contingency Table (for All Sites Combined)
Overall Adjudicated ASCUS
TIS vs. I2**

| | | TIS | | | | | | | |
|----|--------|-------|------|-------|------|-------|------|------|--------|
| | | UNSAT | NILM | ASCUS | LSIL | ASC-H | AGUS | HSIL | Cancer |
| I2 | UNSAT | 2 | 0 | 1 | 0 | 2 | 0 | 0 | 0 |
| | NILM | 1 | 143 | 36 | 7 | 4 | 5 | 2 | 1 |
| | ASCUS | 0 | 76 | 113 | 23 | 15 | 0 | 3 | 0 |
| | LSIL | 1 | 11 | 33 | 45 | 5 | 0 | 2 | 0 |
| | ASC-H | 0 | 16 | 18 | 5 | 37 | 1 | 19 | 0 |
| | AGUS | 1 | 0 | 0 | 0 | 1 | 2 | 0 | 0 |
| | HSIL | 0 | 5 | 6 | 5 | 19 | 0 | 53 | 0 |
| | Cancer | 0 | 0 | 0 | 1 | 0 | 0 | 0 | 0 |

**Table 10. “True LSIL” Contingency Table (for All Sites Combined)
Overall Adjudicated LSIL
TIS vs. I2**

| | | TIS | | | | | | | |
|----|--------|-------|------|-------|------|-------|------|------|--------|
| | | UNSAT | NILM | ASCUS | LSIL | ASC-H | AGUS | HSIL | Cancer |
| I2 | UNSAT | 1 | 0 | 0 | 0 | 0 | 0 | 0 | 0 |
| | NILM | 0 | 13 | 11 | 8 | 0 | 0 | 1 | 0 |
| | ASCUS | 0 | 18 | 107 | 49 | 4 | 0 | 1 | 0 |
| | LSIL | 0 | 19 | 86 | 516 | 10 | 0 | 17 | 0 |
| | ASC-H | 0 | 3 | 12 | 13 | 16 | 1 | 16 | 9 |
| | AGUS | 0 | 0 | 0 | 0 | 0 | 0 | 0 | 0 |
| | HSIL | 0 | 1 | 3 | 40 | 11 | 2 | 107 | 0 |
| | Cancer | 0 | 0 | 0 | 2 | 0 | 0 | 0 | 1 |

**Table 11. “True ASC-H” Contingency Table (for All Sites Combined)
Overall Adjudicated ASC-H
TIS vs. I2**

| | | TIS | | | | | | | |
|----|--------|-------|------|-------|------|-------|------|------|--------|
| | | UNSAT | NILM | ASCUS | LSIL | ASC-H | AGUS | HSIL | Cancer |
| I2 | UNSAT | 0 | 0 | 0 | 0 | 1 | 0 | 0 | 0 |
| | NILM | 0 | 5 | 4 | 0 | 2 | 1 | 1 | 0 |
| | ASCUS | 0 | 9 | 16 | 1 | 13 | 0 | 4 | 0 |
| | LSIL | 0 | 1 | 3 | 2 | 7 | 0 | 1 | 0 |
| | ASC-H | 0 | 4 | 14 | 1 | 31 | 1 | 9 | 0 |
| | AGUS | 0 | 1 | 1 | 0 | 0 | 0 | 0 | 0 |
| | HSIL | 0 | 4 | 4 | 2 | 17 | 0 | 31 | 1 |
| | Cancer | 0 | 0 | 1 | 0 | 0 | 0 | 0 | 2 |

**Table 12. “True AGUS” Contingency Table (for All Sites Combined)
Overall Adjudicated AGUS
TIS vs. I2**

| | | TIS | | | | | | | |
|----|--------|-------|------|-------|------|-------|------|------|--------|
| | | UNSAT | NILM | ASCUS | LSIL | ASC-H | AGUS | HSIL | Cancer |
| I2 | UNSAT | 1 | 0 | 0 | 0 | 0 | 0 | 0 | 0 |
| | NILM | 1 | 30 | 2 | 0 | 1 | 3 | 0 | 0 |
| | ASCUS | 0 | 2 | 0 | 0 | 1 | 0 | 1 | 0 |
| | LSIL | 0 | 0 | 0 | 0 | 0 | 0 | 0 | 0 |
| | ASC-H | 0 | 1 | 0 | 0 | 4 | 1 | 2 | 0 |
| | AGUS | 2 | 10 | 3 | 0 | 1 | 12 | 1 | 1 |
| | HSIL | 1 | 2 | 2 | 0 | 4 | 3 | 9 | 0 |
| | Cancer | 2 | 2 | 1 | 0 | 0 | 1 | 1 | 9 |

**Table 13. “True HSIL” Contingency Table (for All Sites Combined)
Overall Adjudicated HSIL
TIS vs. I2**

| | | TIS | | | | | | | |
|----|--------|-------|------|-------|------|-------|------|------|--------|
| | | UNSAT | NILM | ASCUS | LSIL | ASC-H | AGUS | HSIL | Cancer |
| I2 | UNSAT | 0 | 0 | 0 | 0 | 0 | 0 | 0 | 0 |
| | NILM | 0 | 4 | 0 | 0 | 0 | 0 | 0 | 0 |
| | ASCUS | 0 | 3 | 12 | 1 | 7 | 0 | 2 | 1 |
| | LSIL | 0 | 2 | 7 | 28 | 7 | 0 | 5 | 0 |
| | ASC-H | 0 | 0 | 16 | 13 | 58 | 1 | 23 | 2 |
| | AGUS | 0 | 1 | 3 | 0 | 1 | 1 | 3 | 0 |
| | HSIL | 0 | 3 | 12 | 26 | 44 | 6 | 243 | 5 |
| | Cancer | 0 | 0 | 0 | 1 | 0 | 1 | 16 | 12 |

**Table 14. “True Cancer” Contingency Table (for All Sites Combined)
Overall Adjudicated Cancer
TIS vs. I2**

| | | TIS | | | | | | | |
|----|--------|-------|------|-------|------|-------|------|------|--------|
| | | UNSAT | NILM | ASCUS | LSIL | ASC-H | AGUS | HSIL | Cancer |
| I2 | UNSAT | 0 | 0 | 0 | 0 | 0 | 0 | 0 | 0 |
| | NILM | 0 | 0 | 0 | 0 | 0 | 0 | 0 | 0 |
| | ASCUS | 0 | 0 | 0 | 0 | 1 | 0 | 0 | 0 |
| | LSIL | 0 | 0 | 1 | 0 | 0 | 0 | 0 | 0 |
| | ASC-H | 0 | 0 | 1 | 1 | 2 | 0 | 0 | 0 |
| | AGUS | 0 | 0 | 0 | 1 | 0 | 6 | 0 | 8 |
| | HSIL | 0 | 0 | 0 | 0 | 1 | 0 | 19 | 1 |
| | Cancer | 0 | 0 | 0 | 0 | 0 | 4 | 5 | 63 |

Table 15 shows the descriptive diagnosis marginal frequencies for benign cellular changes for all sites combined. Each slide was read three times, first by a cytotechnologist and then by a pathologist.

**Table 15. Unadjudicated Marginal Frequencies -
Summary of Descriptive Diagnosis for Benign Cellular Changes –
All Sites Combined.**

| Number of reads Descriptive Diagnosis | TIS Review | | I2 Review | |
|--|------------|------|-----------|------|
| | 7542 | | 7542 | |
| | N | % | N | % |
| Benign Cellular Changes | 402 | 5.3% | 420 | 5.6% |
| Organisms: | | | | |
| Trichomonas vaginalis | 20 | 0.3% | 28 | 0.4% |
| Fungal organisms consistent with Candida spp. | 122 | 1.6% | 128 | 1.7% |
| Shift in Flora s/o bacterial vaginosis | 183 | 2.4% | 208 | 2.8% |
| Bacteria consistent with Actinomyces spp. | 2 | 0.0% | 3 | 0.0% |
| Cellular changes consistent with Herpes virus | 2 | 0.0% | 1 | 0.0% |
| Other infection | 0 | 0.0% | 0 | 0.0% |
| Other Non-Neoplastic Findings | | | | 0.0% |
| Reactive cellular changes assoc. w/ inflammation | 34 | 0.5% | 16 | 0.2% |
| Atrophy | 33 | 0.4% | 26 | 0.3% |
| Reactive cellular changes assoc. w/ radiation | 0 | 0.0% | 0 | 0.0% |
| Reactive cellular changes assoc. w/ IUD | 0 | 0.0% | 1 | 0.0% |
| Glandular cells status post hysterectomy | 0 | 0.0% | 0 | 0.0% |
| Endometrial cells in a woman ≥ 45 yrs of age | 6 | 0.1% | 9 | 0.1% |

The Integrated Imager showed a slightly higher rate of Benign Cellular Changes (420 out of 7542, or 5.6%) than TIS Review (402 out of 7542, or 5.3%), however this was not statistically significant.

Conclusion

The sensitivity and specificity of Integrated Imager for review of ThinPrep 2000 and ThinPrep 5000 slides are similar to the sensitivity and specificity of the ThinPrep Imaging System.

G2.3 Analytical performance of Integrated Imager

Within-instrument Reproducibility

Analytical performance was evaluated by reviewing the content of the 22 fields of view (FOVs) presented by the Integrated Imager. Evaluations were carried out by Cytotechnologists. No Pathologist reviewed the FOV. Full slide reviews were not carried out for this evaluation.

Within-instrument reproducibility results were collected by 3 Cytotechnologists who performed review of slides 3 times on the same instrument with a washout period of a minimum of 14 days.

The 260 slides used in this study were previously prepared from ThinPrep specimens and had an adjudicated cytology diagnosis.

The highest ranked diagnosis from review of 22 FOVs and number of abnormal FOVs were recorded for each of three runs for both TIS review and I2 review.

In Table 16, the within-instrument results are summarized for each diagnostic category of slides (according to adjudicated truth results). For each grouping, the following metrics are reported:

- % Abnormal – the proportion of slides for which any abnormal FOVs were observed. (For NILM or UNSAT slides, the % Normal column is used to record the proportion that are not abnormal).
- % Category+ – the proportion of slides for which at least one FOV was observed with content of the slide’s true category or higher.
- % N/A – the proportion of slides in that category that are excluded from analysis (slide not able to be imaged by imager or missing data)
- Abnormal FOV, % zero – the proportion of slides for which zero abnormal FOV were observed.
- Abnormal FOV, Median – the median number of abnormal FOV observed (out of 22 total).

Table 16. Summarized Results of Within-instrument Study

| Dx | Imager | % Abnormal | % Category+ | % Normal | % N/A | Abnormal FOV | |
|--------|--------|------------|-------------|----------|-------|--------------|--------|
| | | | | | | % zero | Median |
| NILM | TIS | | | 69.6% | 11.0% | 70.4% | 0 |
| | I2 | | | 78.1% | 4.3% | 78.4% | 0 |
| ASCUS | TIS | 75.9% | 75.9% | | 13.3% | 25.0% | 6 |
| | I2 | 71.9% | 71.9% | | 5.0% | 28.1% | 7 |
| LSIL | TIS | 97.3% | 93.2% | | 3.3% | 2.8% | 14 |
| | I2 | 96.0% | 94.0% | | 0.7% | 4.0% | 15 |
| ASC-H | TIS | 93.3% | 86.7% | | 0.0% | 6.7% | 11.5 |
| | I2 | 100% | 83.3% | | 0.0% | 0.0% | 14 |
| AGUS | TIS | 63.0% | 51.9% | | 6.7% | 35.7% | 2 |
| | I2 | 55.6% | 48.1% | | 10.0% | 44.4% | 2 |
| HSIL | TIS | 98.0% | 77.3% | | 0.0% | 2.0% | 20 |
| | I2 | 97.3% | 71.3% | | 0.7% | 2.7% | 20 |
| CANCER | TIS | 100% | 46.7% | | 0.0% | 0.0% | 22 |
| | I2 | 100% | 53.3% | | 0.0% | 0.0% | 22 |
| UNSAT | TIS | | | 72.2% | 40.0% | 72.2% | 0 |
| | I2 | | | 85.7% | 36.7% | 94.7% | 0 |

Between-instrument Reproducibility

Between-instrument reproducibility results were derived from the clinical study. In the clinical study, 3 Cytotechnologist/Pathologist pairs reviewed slides on different instruments.

In Table 17, the between-instrument results are summarized for each diagnostic category of slides (according to adjudicated truth results). For each grouping, the following metrics are reported:

- % Abnormal – the proportion of slides for which any abnormal diagnosis was recorded. (For NILM or UNSAT slides, the % Normal column is used to record the proportion that are not abnormal).
- % Category+ - the proportion of slides for which the site diagnosis was equal to or higher than the slide’s adjudicated category.

Table 17. Summarized Results of Between-instrument Study

| Dx | Imager | % Abnormal | % Category+ | % Normal |
|---------------|---------------|-------------------|--------------------|-----------------|
| NILM | TIS | -- | -- | 90.0% |
| | I2 | -- | -- | 88.1% |
| ASCUS | TIS | 64.4% | 64.4% | -- |
| | I2 | 71.7% | 71.7% | -- |
| LSIL | TIS | 95.0% | 75.0% | -- |
| | I2 | 96.9% | 80.6% | -- |
| ASC-H | TIS | 87.7% | 62.6% | -- |
| | I2 | 92.8% | 63.6% | -- |
| AGUS | TIS | 53.8% | 37.6% | -- |
| | I2 | 67.5% | 57.3% | -- |
| HSIL | TIS | 97.7% | 54.7% | -- |
| | I2 | 99.3% | 64.7% | -- |
| CANCER | TIS | 100% | 63.2% | -- |
| | I2 | 100% | 63.2% | -- |
| UNSAT | TIS | -- | -- | 95.2% |
| | I2 | -- | -- | 93.2% |

G2.4 Cytotechnologist Screening Rates During Clinical Study

During the study, nine cytotechnologists (CTs) recorded the number of hours they worked each day and the number of slides screened for both the TIS and I2 reviews. The experience levels of the cytologists ranged from 4 to 30 years. During the study, the cytotechnologist’s screening times for both TIS Review and I2 Review included automated screening of the 22 fields of view, full slide review if the automated screening was not applicable, and automated screening of the 22 fields of view followed by full slide review when abnormal cells were identified during automated screening. The number of hours each cytotechnologist screened slides per day varied due to logistical issues and scheduling. Only the sequential modality of I2 Review was evaluated during clinical study.

These data are summarized in Table 18 below.

Note: These numbers represent total number of slides and does not consider the review type; Field of view (FOV) only, Full Manual Review (FMR), or FOV+FMR. These rates are lower than would be routinely observed in clinical practice as the number of abnormal cases in this clinical study was much higher than typically observed in normal clinical practice (50% versus 10-20%).

Table 18. CT Screening Rates

| | TIS Average slides/hour | I2 Average slides/hour |
|------------------------|--|---------------------------------------|
| Site 1 | | |
| CT 1 | 9.8 | 9.9 |
| CT 2 | 10.4 | 9.7 |
| CT 3 | 11.1 | 8.1 |
| Site 2 | | |
| CT 1 | 6.2 | 6.1 |
| CT 2 | 9.0 | 6.4 |
| CT 3 | 9.1 | 6.5 |
| Site 3 | | |
| CT 1 | 9.2 | 6.6 |
| CT 2 | 9.9 | 6.8 |
| CT 3 | 10.1 | 6.5 |
| Combined Median | 9.8 | 6.6 |
| | 100% | 67% |

In this study, the number of equivalent slides reviewed could not be determined as the review type was not tracked.

CTs using the Integrated Imager scanned and reviewed 67% of the slides that CTs reviewed when using TIS.

Note: The time recorded for the TIS reviewed slides does not account for the scanning time. The scanning time adds approximately 90 seconds per slide when using the Integrated Imager Sequential Modality.

G2.5 Cytotechnologist Timing Study (Batched and Sequential Modalities)

An additional study “Cytotechnologist Screening Time Study ThinPrep® Integrated Imager” was performed to characterize the screening volumes for cytotechnologists (CTs) when assistive imaging is implemented as part of the slide review process. These data were collected using the Integrated Imager in two ways:

- 1.) Each slide was imaged and then reviewed by a CT using the Integrated Imager. This is referred to as *Sequential Modality* in this study (i.e., imaging and slide review is performed consecutively, by the CT).
- 2.) All slides were imaged as a batch using the Integrated Imager and then the CT reviewed slides as a batch. This is referred to as *Batched Modality* in this study. In batched modality, imaging of slides is performed in advance, separate from the slide review.

Three CTs participated in this study. The CTs reviewed slides over three days (screening slides for an 8 hour day) for each arm of the study. Slides were imaged and reviewed independently by each of the three CTs.

All slides were prepared from ThinPrep® specimens of known cytology diagnoses, on a ThinPrep processor, and stained with ThinPrep Stain. Sets of 400 randomized slides per CT, each with approximately 10% abnormal diagnosis were provided in order to fully occupy a CT for 3 full days of screening. The CTs were blinded to the diagnoses.

A minimum one week “washout period” occurred between study arms for each CT.

Table 19 shows the total breakdown of the types of reviews performed in the CT Timing Study

Table 19. Total Slides Reviewed by Review Type / CT
 (% Autoscan = #FOV+FMR / Total # slides reviewed over 3 days)

| | Sequential Review | | | | Batched Review | | | |
|--------------------------------|-------------------|-------|-------|---------|----------------|-------|-------|---------|
| | CT #1 | CT #2 | CT #3 | Overall | CT #1 | CT #2 | CT #3 | Overall |
| Total # slides reviewed | 255 | 285 | 300 | 840 | 365 | 340 | 353 | 1058 |
| # FOV only | 212 | 179 | 239 | 630 | 308 | 226 | 265 | 799 |
| # FOV+FMR | 42 | 100 | 37 | 179 | 51 | 109 | 75 | 235 |
| # FMR Only | 1 | 6 | 4 | 11 | 6 | 5 | 13 | 24 |
| % Autoscan Referral | 16% | 35% | 19% | 24% | 14% | 32% | 21% | 22% |

The results are shown in **Table 20**. The median number of slides screened per day when the Integrated Imager in Sequential Modality was used for screening and reviewing of slides was **92** slides. CTs using the Integrated Imager in Batched Modality reviewed 86% of the maximum number of slides that CTs could have reviewed when using TIS.

Table 20. Cytotechnologist Daily Slide Review Rates

| | CT | # Slides Reviewed | | | | Overall Daily Median |
|----------------------------|--------------|-------------------|-------|-------|--------------|----------------------|
| | | Day 1 | Day 2 | Day 3 | Daily Median | |
| Sequential Modality | CT #1 | 87 | 80 | 88 | 87 | 92 (67%*) |
| | CT #2 | 90 | 100 | 95 | 95 | |
| | CT #3 | 92 | 108 | 100 | 100 | |
| Batched Modality | CT #1 | 119 | 123 | 123 | 123 | 119 (86%*) |
| | CT #2 | 124 | 106 | 110 | 110 | |
| | CT #3 | 119 | 120 | 114 | 119 | |

* Percentage with regards to TIS being 100%.

The agreement of the CT diagnosis was compared to the adjudicated results and are shown in Table 21. High rates of agreement in diagnosis with the adjudicated slide results supports the clinical utility of this study.

**Table 21. PPA and NPA Results by Cytotechnologist Based on Adjudicated Results.
(Positive Results Mean ASC-US+)**

| | Sequential Modality | | Batched Modality | |
|----------------|---------------------|-----|------------------|-----|
| | PPA | NPA | PPA | NPA |
| CT #1 | 100% | 97% | 97% | 96% |
| CT #2 | 100% | 76% | 100% | 79% |
| CT #3 | 91% | 94% | 100% | 90% |
| Overall | 97% | 89% | 99% | 89% |

Workload is defined by CLIA as a maximum limit of 100 slides in no less than an 8-hour workday. This refers to a full manual review of 100 slides.

When using automated Imaging systems, users may need to review only a portion of the slide in order to make a diagnosis of NILM, thereby decreasing the time needed for CT review. Conversely, in cases where abnormality is present, the partial slide review is followed by a full manual review, leading to a longer CT review time. In both cases, different values are used to account for the difference in review times in order to arrive at slide workload estimates (see Tables 22 and 23).

When using the Sequential Modality, the Integrated Imager scans the slide in approximately 90 seconds. This time should be considered when determining the value used for workload calculations.

When using the Batched Modality, the scanning time is not considered in the review time, and as such, more slides can be reviewed in an 8 hour day.

In order to help laboratories determine the workload, based on the number of slides reviewed with FOV only and FOV+FMR, for their cytotechnologists when using the Integrated Imager, laboratories should use the following method in **Table 22 and Table 24 for Sequential Modality and Table 23 and Table 25 for Batched Modality** when calculating workload.

Tables 24 and 25 are intended to help individual cytotechnologists keep an on-going tally of the FOV only and FOV+FMR slides screened during each workday.

**Table 22. Values for Calculating Workload,
Integrated Imager, Sequential Modality**

| |
|---------------------------------|
| FMR = 1 slide |
| FOV = 0.85 slide |
| FMR + FOV = 1.85 slides |
| Upper Limit = 100 slides |

When using Sequential Modality, use the following equation for determining workload:

$$[(\# \text{ slides FMR}) (1) + (\# \text{ slides FOV}) (0.85) + (\# \text{ slides FOV+FMR}) (1.85)] = 100 \text{ slides}$$

Table 23. Values for Calculating Workload, Integrated Imager, Batched Modality

| |
|---|
| <p>FMR = 1 slide FOV = 0.65 slide FMR + FOV = 1.65 slides Upper Limit = 100 slides</p> |
|---|

When using Batched Modality, use the following equation for determining workload:

$$[(\# \text{ slides FMR}) (1) + (\# \text{ slides FOV}) (0.65) + (\# \text{ slides FOV+FMR}) (1.65)] = 100 \text{ slides}$$

Note: The ThinPrep® Integrated Imager workload limit in an 8-hour workday includes all activities needed to process the cases, not exclusively time spent using the microscope:

- Screening 22 Fields of View
 - Full manual slide review using the Autoscan feature
 - Review clinical history
 - Record results and triage appropriately
- Slides where only 22 Fields of View (FOV) are used for diagnosis should be considered as less than a full slide.
 - When using the *Sequential Modality*, a slide should be considered as 0.85 of a slide.
 - When the *Batched Modality* is used, a slide should be considered 0.65 of a slide
 - Slides where full manual review (FMR) are performed using either manual stage indexing, or with the Autoscan feature: should be considered as 1 slide (as mandated by CLIA '88 for manual screening).
 - Slides where **both** FOV review and a FMR are conducted should be considered as :
 - 1.85 slides when using Sequential Modality,
 - 1.65 slides when using Batched Modality.
 - If less than an 8-hour workday is practiced, the following formula must be applied to determine the maximum number of slides to be reviewed during that workday:

$$\left(\frac{\text{Number of hours examining slides}}{8} \right) \times 100$$

- **Note:** ALL laboratories should have a clear standard operation procedure for documentation of their method of workload counting and for establishing workload limits.
- It is the responsibility of the Technical Supervisor to evaluate and set workload limits for individual cytotechnologists based on laboratory clinical performance.
- **Note:** The manual workload limit does not supersede the CLIA requirement of 100 slides in a 24-hour period in no less than an 8-hour day. When conducting manual review, refer to the CLIA requirements for calculating workload limits. Manual review includes the following types of slides:
 - Slides reviewed on the ThinPrep Imaging System using the Autoscan feature
 - Slides reviewed without the ThinPrep Imaging System
 - Non-gynecologic slides.
- According to CLIA '88, these workload limits should be reassessed every six months.

Table 24. Screening Work Completion Look up Table – Integrated Imager, Sequential Modality

| | | FOV+FMR | | | | | | | | | | | | | | | | | | | | | | | | | | | | | | | | | | | | | | | | | | | | | | | | | | | | | | | | |
|-----|----|---------|----|----|----|----|----|----|----|----|----|----|----|----|----|----|----|----|----|----|----|----|----|----|----|----|----|----|----|----|----|----|----|----|----|----|----|----|----|----|----|-----|----|-----|-----|----|----|-----|-----|-----|-----|----|----|-----|-----|-----|--|--|
| | | 0 | 1 | 2 | 3 | 4 | 5 | 6 | 7 | 8 | 9 | 10 | 11 | 12 | 13 | 14 | 15 | 16 | 17 | 18 | 19 | 20 | 21 | 22 | 23 | 24 | 25 | 26 | 27 | 28 | 29 | 30 | 31 | 32 | 33 | 34 | 35 | 36 | 37 | 38 | 39 | 40 | 41 | 42 | 43 | 44 | 45 | 46 | 47 | 48 | 49 | 50 | 51 | 52 | 53 | 54 | | |
| FOV | 0 | 0 | 2 | 4 | 6 | 7 | 9 | 11 | 13 | 15 | 17 | 19 | 20 | 22 | 24 | 26 | 28 | 30 | 31 | 33 | 35 | 37 | 39 | 41 | 43 | 44 | 46 | 48 | 50 | 52 | 54 | 56 | 57 | 59 | 61 | 63 | 65 | 67 | 68 | 70 | 72 | 74 | 76 | 78 | 80 | 81 | 83 | 85 | 87 | 89 | 91 | 93 | 94 | 96 | 98 | 100 | | |
| | 1 | 1 | 3 | 5 | 6 | 8 | 10 | 12 | 14 | 16 | 18 | 19 | 21 | 23 | 25 | 27 | 29 | 30 | 32 | 34 | 36 | 38 | 40 | 42 | 43 | 45 | 47 | 49 | 51 | 53 | 55 | 56 | 58 | 60 | 62 | 64 | 66 | 67 | 69 | 71 | 73 | 75 | 77 | 79 | 80 | 82 | 84 | 86 | 88 | 90 | 92 | 93 | 95 | 97 | 99 | | | |
| | 2 | 2 | 4 | 5 | 7 | 9 | 11 | 13 | 15 | 17 | 18 | 20 | 22 | 24 | 26 | 28 | 29 | 31 | 33 | 35 | 37 | 39 | 41 | 42 | 44 | 46 | 48 | 50 | 52 | 54 | 55 | 57 | 59 | 61 | 63 | 65 | 66 | 68 | 70 | 72 | 74 | 76 | 78 | 79 | 81 | 83 | 85 | 87 | 89 | 91 | 92 | 94 | 96 | 98 | 100 | | | |
| | 3 | 3 | 4 | 6 | 8 | 10 | 12 | 14 | 16 | 17 | 19 | 21 | 23 | 25 | 27 | 28 | 30 | 32 | 34 | 36 | 38 | 40 | 41 | 43 | 45 | 47 | 49 | 51 | 53 | 54 | 56 | 58 | 60 | 62 | 64 | 65 | 67 | 69 | 71 | 73 | 75 | 77 | 78 | 80 | 82 | 84 | 86 | 88 | 90 | 91 | 93 | 95 | 97 | 99 | | | | |
| | 4 | 3 | 5 | 7 | 9 | 11 | 13 | 15 | 16 | 18 | 20 | 22 | 24 | 26 | 27 | 29 | 31 | 33 | 35 | 37 | 39 | 40 | 42 | 44 | 46 | 48 | 50 | 52 | 53 | 55 | 57 | 59 | 61 | 63 | 64 | 66 | 68 | 70 | 72 | 74 | 76 | 77 | 79 | 81 | 83 | 85 | 87 | 89 | 90 | 92 | 94 | 96 | 98 | 100 | | | | |
| | 5 | 4 | 6 | 8 | 10 | 12 | 14 | 15 | 17 | 19 | 21 | 23 | 25 | 26 | 28 | 30 | 32 | 34 | 36 | 38 | 39 | 41 | 43 | 45 | 47 | 49 | 51 | 52 | 54 | 56 | 58 | 60 | 62 | 63 | 65 | 67 | 69 | 71 | 73 | 75 | 76 | 78 | 80 | 82 | 84 | 86 | 88 | 89 | 91 | 93 | 95 | 97 | 99 | | | | | |
| | 6 | 5 | 7 | 9 | 11 | 13 | 14 | 16 | 18 | 20 | 22 | 24 | 25 | 27 | 29 | 31 | 33 | 35 | 37 | 38 | 40 | 42 | 44 | 46 | 48 | 50 | 51 | 53 | 55 | 57 | 59 | 61 | 62 | 64 | 66 | 68 | 70 | 72 | 74 | 75 | 77 | 79 | 81 | 83 | 85 | 87 | 88 | 90 | 92 | 94 | 96 | 98 | 99 | | | | | |
| | 7 | 6 | 8 | 10 | 12 | 13 | 15 | 17 | 19 | 21 | 23 | 24 | 26 | 28 | 30 | 32 | 34 | 36 | 37 | 39 | 41 | 43 | 45 | 47 | 49 | 50 | 52 | 54 | 56 | 58 | 60 | 61 | 63 | 65 | 67 | 69 | 71 | 73 | 74 | 76 | 78 | 80 | 82 | 84 | 86 | 87 | 89 | 91 | 93 | 95 | 97 | 98 | | | | | | |
| | 8 | 7 | 9 | 11 | 12 | 14 | 16 | 18 | 20 | 22 | 23 | 25 | 27 | 29 | 31 | 33 | 35 | 36 | 38 | 40 | 42 | 44 | 46 | 48 | 49 | 51 | 53 | 55 | 57 | 59 | 60 | 62 | 64 | 66 | 68 | 70 | 72 | 73 | 75 | 77 | 79 | 81 | 83 | 85 | 86 | 88 | 90 | 92 | 94 | 96 | 97 | 99 | | | | | | |
| | 9 | 8 | 10 | 11 | 13 | 15 | 17 | 19 | 21 | 22 | 24 | 26 | 28 | 30 | 32 | 34 | 35 | 37 | 39 | 41 | 43 | 45 | 47 | 48 | 50 | 52 | 54 | 56 | 58 | 59 | 61 | 63 | 65 | 67 | 69 | 71 | 72 | 74 | 76 | 78 | 80 | 82 | 84 | 85 | 87 | 89 | 91 | 93 | 95 | 96 | 98 | | | | | | | |
| | 10 | 9 | 10 | 12 | 14 | 16 | 18 | 20 | 21 | 23 | 25 | 27 | 29 | 31 | 33 | 34 | 36 | 38 | 40 | 42 | 44 | 46 | 47 | 49 | 51 | 53 | 55 | 57 | 58 | 60 | 62 | 64 | 66 | 68 | 70 | 71 | 73 | 75 | 77 | 79 | 81 | 83 | 84 | 86 | 88 | 90 | 92 | 94 | 95 | 97 | 99 | | | | | | | |
| | 11 | 9 | 11 | 13 | 15 | 17 | 19 | 20 | 22 | 24 | 26 | 28 | 30 | 32 | 33 | 35 | 37 | 39 | 41 | 43 | 45 | 46 | 48 | 50 | 52 | 54 | 56 | 57 | 59 | 61 | 63 | 65 | 67 | 69 | 70 | 72 | 74 | 76 | 78 | 80 | 82 | 83 | 85 | 87 | 89 | 91 | 93 | 94 | 96 | 98 | 100 | | | | | | | |
| | 12 | 10 | 12 | 14 | 16 | 18 | 19 | 21 | 23 | 25 | 27 | 29 | 31 | 32 | 34 | 36 | 38 | 40 | 42 | 44 | 45 | 47 | 49 | 51 | 53 | 55 | 56 | 58 | 60 | 62 | 64 | 66 | 68 | 69 | 71 | 73 | 75 | 77 | 79 | 81 | 82 | 84 | 86 | 88 | 90 | 92 | 93 | 95 | 97 | 99 | | | | | | | | |
| | 13 | 11 | 13 | 15 | 17 | 18 | 20 | 22 | 24 | 26 | 28 | 30 | 31 | 33 | 35 | 37 | 39 | 41 | 43 | 44 | 46 | 48 | 50 | 52 | 54 | 55 | 57 | 59 | 61 | 63 | 65 | 67 | 68 | 70 | 72 | 74 | 76 | 78 | 80 | 81 | 83 | 85 | 87 | 89 | 91 | 92 | 94 | 96 | 98 | 100 | | | | | | | | |
| | 14 | 12 | 14 | 16 | 17 | 19 | 21 | 23 | 25 | 27 | 29 | 30 | 32 | 34 | 36 | 38 | 40 | 42 | 43 | 45 | 47 | 49 | 51 | 53 | 54 | 56 | 58 | 60 | 62 | 64 | 66 | 67 | 69 | 71 | 73 | 75 | 77 | 79 | 80 | 82 | 84 | 86 | 88 | 90 | 91 | 93 | 95 | 97 | 99 | | | | | | | | | |
| | 15 | 13 | 15 | 16 | 18 | 20 | 22 | 24 | 26 | 28 | 29 | 31 | 33 | 35 | 37 | 39 | 41 | 42 | 44 | 46 | 48 | 50 | 52 | 53 | 55 | 57 | 59 | 61 | 63 | 65 | 66 | 68 | 70 | 72 | 74 | 76 | 78 | 79 | 81 | 83 | 85 | 87 | 89 | 90 | 92 | 94 | 96 | 98 | 100 | | | | | | | | | |
| | 16 | 14 | 15 | 17 | 19 | 21 | 23 | 25 | 27 | 28 | 30 | 32 | 34 | 36 | 38 | 40 | 41 | 43 | 45 | 47 | 49 | 51 | 52 | 54 | 56 | 58 | 60 | 62 | 64 | 65 | 67 | 69 | 71 | 73 | 75 | 77 | 78 | 80 | 82 | 84 | 86 | 88 | 89 | 91 | 93 | 95 | 97 | 99 | | | | | | | | | | |
| | 17 | 14 | 16 | 18 | 20 | 22 | 24 | 26 | 27 | 29 | 31 | 33 | 35 | 37 | 39 | 40 | 42 | 44 | 46 | 48 | 50 | 51 | 53 | 55 | 57 | 59 | 61 | 63 | 64 | 66 | 68 | 70 | 72 | 74 | 76 | 77 | 79 | 81 | 83 | 85 | 87 | 88 | 90 | 92 | 94 | 96 | 98 | 100 | | | | | | | | | | |
| | 18 | 15 | 17 | 19 | 21 | 23 | 25 | 26 | 28 | 30 | 32 | 34 | 36 | 38 | 39 | 41 | 43 | 45 | 47 | 49 | 50 | 52 | 54 | 56 | 58 | 60 | 62 | 63 | 65 | 67 | 69 | 71 | 73 | 75 | 76 | 78 | 80 | 82 | 84 | 86 | 87 | 89 | 91 | 93 | 95 | 97 | 99 | | | | | | | | | | | |
| | 19 | 16 | 18 | 20 | 22 | 24 | 25 | 27 | 29 | 31 | 33 | 35 | 37 | 38 | 40 | 42 | 44 | 46 | 48 | 49 | 51 | 53 | 55 | 57 | 59 | 61 | 62 | 64 | 66 | 68 | 70 | 72 | 74 | 75 | 77 | 79 | 81 | 83 | 85 | 86 | 88 | 90 | 92 | 94 | 96 | 98 | 99 | | | | | | | | | | | |
| | 20 | 17 | 19 | 21 | 23 | 24 | 26 | 28 | 30 | 32 | 34 | 36 | 37 | 39 | 41 | 43 | 45 | 47 | 48 | 50 | 52 | 54 | 56 | 58 | 60 | 61 | 63 | 65 | 67 | 69 | 71 | 73 | 74 | 76 | 78 | 80 | 82 | 84 | 85 | 87 | 89 | 91 | 93 | 95 | 97 | 98 | | | | | | | | | | | | |
| | 21 | 18 | 20 | 22 | 23 | 25 | 27 | 29 | 31 | 33 | 35 | 36 | 38 | 40 | 42 | 44 | 46 | 47 | 49 | 51 | 53 | 55 | 57 | 59 | 60 | 62 | 64 | 66 | 68 | 70 | 72 | 73 | 75 | 77 | 79 | 81 | 83 | 84 | 86 | 88 | 90 | 92 | 94 | 96 | 97 | 99 | | | | | | | | | | | | |
| | 22 | 19 | 21 | 22 | 24 | 26 | 28 | 30 | 32 | 34 | 35 | 37 | 39 | 41 | 43 | 45 | 46 | 48 | 50 | 52 | 54 | 56 | 58 | 59 | 61 | 63 | 65 | 67 | 69 | 71 | 72 | 74 | 76 | 78 | 80 | 82 | 83 | 85 | 87 | 89 | 91 | 93 | 95 | 96 | 98 | | | | | | | | | | | | | |
| | 23 | 20 | 21 | 23 | 25 | 27 | 29 | 31 | 33 | 34 | 36 | 38 | 40 | 42 | 44 | 45 | 47 | 49 | 51 | 53 | 55 | 57 | 58 | 60 | 62 | 64 | 66 | 68 | 70 | 71 | 73 | 75 | 77 | 79 | 81 | 82 | 84 | 86 | 88 | 90 | 92 | 94 | 95 | 97 | 99 | | | | | | | | | | | | | |
| | 24 | 20 | 22 | 24 | 26 | 28 | 30 | 32 | 33 | 35 | 37 | 39 | 41 | 43 | 44 | 46 | 48 | 50 | 52 | 54 | 56 | 57 | 59 | 61 | 63 | 65 | 67 | 69 | 70 | 72 | 74 | 76 | 78 | 80 | 81 | 83 | 85 | 87 | 89 | 91 | 93 | 94 | 96 | 98 | 100 | | | | | | | | | | | | | |
| | 25 | 21 | 23 | 25 | 27 | 29 | 31 | 32 | 34 | 36 | 38 | 40 | 42 | 43 | 45 | 47 | 49 | 51 | 53 | 55 | 56 | 58 | 60 | 62 | 64 | 66 | 68 | 69 | 71 | 73 | 75 | 77 | 79 | 80 | 82 | 84 | 86 | 88 | 90 | 92 | 93 | 95 | 97 | 99 | | | | | | | | | | | | | | |
| | 26 | 22 | 24 | 26 | 28 | 30 | 31 | 33 | 35 | 37 | 39 | 41 | 42 | 44 | 46 | 48 | 50 | 52 | 54 | 55 | 57 | 59 | 61 | 63 | 65 | 67 | 68 | 70 | 72 | 74 | 76 | 78 | 79 | 81 | 83 | 85 | 87 | 89 | 91 | 92 | 94 | 96 | 98 | 100 | | | | | | | | | | | | | | |
| | 27 | 23 | 25 | 27 | 29 | 30 | 32 | 34 | 36 | 38 | 40 | 41 | 43 | 45 | 47 | 49 | 51 | 53 | 54 | 56 | 58 | 60 | 62 | 64 | 66 | 67 | 69 | 71 | 73 | 75 | 77 | 78 | 80 | 82 | 84 | 86 | 88 | 90 | 91 | 93 | 95 | 97 | 99 | | | | | | | | | | | | | | | |
| 28 | 24 | 26 | 28 | 29 | 31 | 33 | 35 | 37 | 39 | 40 | 42 | 44 | 46 | 48 | 50 | 52 | 53 | 55 | 57 | 59 | 61 | 63 | 65 | 66 | 68 | 70 | 72 | 74 | 76 | 77 | 79 | 81 | 83 | 85 | 87 | 89 | 90 | 92 | 94 | 96 | 98 | 100 | | | | | | | | | | | | | | | | |

Table 25. Screening Work Completion Look up Table – Integrated Imager, Batched Modality

| | | FOV+FMR | | | | | | | | | | | | | | | | | | | | | | | | | | | | | | | | | | | | | | | | | | | | | | | | | | | | | | | | | | | | |
|-----|----|---------|----|----|----|----|----|----|----|----|----|----|----|----|----|----|----|----|----|----|----|----|----|----|----|----|----|----|----|----|----|----|----|----|----|----|----|----|----|----|----|----|----|----|----|----|----|----|----|----|----|----|-----|----|-----|-----|-----|-----|-----|-----|-----|-----|
| | | 0 | 1 | 2 | 3 | 4 | 5 | 6 | 7 | 8 | 9 | 10 | 11 | 12 | 13 | 14 | 15 | 16 | 17 | 18 | 19 | 20 | 21 | 22 | 23 | 24 | 25 | 26 | 27 | 28 | 29 | 30 | 31 | 32 | 33 | 34 | 35 | 36 | 37 | 38 | 39 | 40 | 41 | 42 | 43 | 44 | 45 | 46 | 47 | 48 | 49 | 50 | 51 | 52 | 53 | 54 | 55 | 56 | 57 | 58 | 59 | 60 |
| FOV | 0 | 0 | 2 | 3 | 5 | 7 | 8 | 10 | 12 | 13 | 15 | 17 | 18 | 20 | 21 | 23 | 25 | 26 | 28 | 30 | 31 | 33 | 35 | 36 | 38 | 40 | 41 | 43 | 45 | 46 | 48 | 50 | 51 | 53 | 54 | 56 | 58 | 59 | 61 | 63 | 64 | 66 | 68 | 69 | 71 | 73 | 74 | 76 | 78 | 79 | 81 | 83 | 84 | 86 | 87 | 89 | 91 | 92 | 94 | 96 | 97 | 99 |
| | 1 | 1 | 2 | 4 | 6 | 7 | 9 | 11 | 12 | 14 | 16 | 17 | 19 | 20 | 22 | 24 | 25 | 27 | 29 | 30 | 32 | 34 | 35 | 37 | 39 | 40 | 42 | 44 | 45 | 47 | 49 | 50 | 52 | 53 | 55 | 57 | 58 | 60 | 62 | 63 | 65 | 67 | 68 | 70 | 72 | 73 | 75 | 77 | 78 | 80 | 82 | 83 | 85 | 86 | 88 | 90 | 91 | 93 | 95 | 96 | 98 | 100 |
| | 2 | 1 | 3 | 5 | 6 | 8 | 10 | 11 | 13 | 15 | 16 | 18 | 19 | 21 | 23 | 24 | 26 | 28 | 29 | 31 | 33 | 34 | 36 | 38 | 39 | 41 | 43 | 44 | 46 | 48 | 49 | 51 | 52 | 54 | 56 | 57 | 59 | 61 | 62 | 64 | 66 | 67 | 69 | 71 | 72 | 74 | 76 | 77 | 79 | 81 | 82 | 84 | 85 | 87 | 89 | 90 | 92 | 94 | 95 | 97 | 99 | |
| | 3 | 2 | 4 | 5 | 7 | 9 | 10 | 12 | 14 | 15 | 17 | 18 | 20 | 22 | 23 | 25 | 27 | 28 | 30 | 32 | 33 | 35 | 37 | 38 | 40 | 42 | 43 | 45 | 47 | 48 | 50 | 51 | 53 | 55 | 56 | 58 | 60 | 61 | 63 | 65 | 66 | 68 | 70 | 71 | 73 | 75 | 76 | 78 | 80 | 81 | 83 | 84 | 86 | 88 | 89 | 91 | 93 | 94 | 96 | 98 | 99 | |
| | 4 | 3 | 4 | 6 | 8 | 9 | 11 | 13 | 14 | 16 | 17 | 19 | 21 | 22 | 24 | 26 | 27 | 29 | 31 | 32 | 34 | 36 | 37 | 39 | 41 | 42 | 44 | 46 | 47 | 49 | 50 | 52 | 54 | 55 | 57 | 59 | 60 | 62 | 64 | 65 | 67 | 69 | 70 | 72 | 74 | 75 | 77 | 79 | 80 | 82 | 83 | 85 | 87 | 88 | 90 | 92 | 93 | 95 | 97 | 98 | 100 | |
| | 5 | 3 | 5 | 7 | 8 | 10 | 12 | 13 | 15 | 16 | 18 | 20 | 21 | 23 | 25 | 26 | 28 | 30 | 31 | 33 | 35 | 36 | 38 | 40 | 41 | 43 | 45 | 46 | 48 | 49 | 51 | 53 | 54 | 56 | 58 | 59 | 61 | 63 | 64 | 66 | 68 | 69 | 71 | 73 | 74 | 76 | 78 | 79 | 81 | 82 | 84 | 86 | 87 | 89 | 91 | 92 | 94 | 96 | 97 | 99 | | |
| | 6 | 4 | 6 | 7 | 9 | 11 | 12 | 14 | 15 | 17 | 19 | 20 | 22 | 24 | 25 | 27 | 29 | 30 | 32 | 34 | 35 | 37 | 39 | 40 | 42 | 44 | 45 | 47 | 48 | 50 | 52 | 53 | 55 | 57 | 58 | 60 | 62 | 63 | 65 | 67 | 68 | 70 | 72 | 73 | 75 | 77 | 78 | 80 | 81 | 83 | 85 | 86 | 88 | 90 | 91 | 93 | 95 | 96 | 98 | 100 | | |
| | 7 | 5 | 6 | 8 | 10 | 11 | 13 | 14 | 16 | 18 | 19 | 21 | 23 | 24 | 26 | 28 | 29 | 31 | 33 | 34 | 36 | 38 | 39 | 41 | 43 | 44 | 46 | 47 | 49 | 51 | 52 | 54 | 56 | 57 | 59 | 61 | 62 | 64 | 66 | 67 | 69 | 71 | 72 | 74 | 76 | 77 | 79 | 80 | 82 | 84 | 85 | 87 | 89 | 90 | 92 | 94 | 95 | 97 | 99 | | | |
| | 8 | 5 | 7 | 9 | 10 | 12 | 13 | 15 | 17 | 18 | 20 | 22 | 23 | 25 | 27 | 28 | 30 | 32 | 33 | 35 | 37 | 38 | 40 | 42 | 43 | 45 | 46 | 48 | 50 | 51 | 53 | 55 | 56 | 58 | 60 | 61 | 63 | 65 | 66 | 68 | 70 | 71 | 73 | 75 | 76 | 78 | 79 | 81 | 83 | 84 | 86 | 88 | 89 | 91 | 93 | 94 | 96 | 98 | 99 | | | |
| | 9 | 6 | 8 | 9 | 11 | 12 | 14 | 16 | 17 | 19 | 21 | 22 | 24 | 26 | 27 | 29 | 31 | 32 | 34 | 36 | 37 | 39 | 41 | 42 | 44 | 45 | 47 | 49 | 50 | 52 | 54 | 55 | 57 | 59 | 60 | 62 | 64 | 65 | 67 | 69 | 70 | 72 | 74 | 75 | 77 | 78 | 80 | 82 | 83 | 85 | 87 | 88 | 90 | 92 | 93 | 95 | 97 | 98 | 100 | | | |
| | 10 | 7 | 8 | 10 | 11 | 13 | 15 | 16 | 18 | 20 | 21 | 23 | 25 | 26 | 28 | 30 | 31 | 33 | 35 | 36 | 38 | 40 | 41 | 43 | 44 | 46 | 48 | 49 | 51 | 53 | 54 | 56 | 58 | 59 | 61 | 63 | 64 | 66 | 68 | 69 | 71 | 73 | 74 | 76 | 77 | 79 | 81 | 82 | 84 | 86 | 87 | 89 | 91 | 92 | 94 | 96 | 97 | 99 | | | | |
| | 11 | 7 | 9 | 10 | 12 | 14 | 15 | 17 | 19 | 20 | 22 | 24 | 25 | 27 | 29 | 30 | 32 | 34 | 35 | 37 | 39 | 40 | 42 | 43 | 45 | 47 | 48 | 50 | 52 | 53 | 55 | 57 | 58 | 60 | 62 | 63 | 65 | 67 | 68 | 70 | 72 | 73 | 75 | 76 | 78 | 80 | 81 | 83 | 85 | 86 | 88 | 90 | 91 | 93 | 95 | 96 | 98 | 100 | | | | |
| | 12 | 8 | 9 | 11 | 13 | 14 | 16 | 18 | 19 | 21 | 23 | 24 | 26 | 28 | 29 | 31 | 33 | 34 | 36 | 38 | 39 | 41 | 42 | 44 | 46 | 47 | 49 | 51 | 52 | 54 | 56 | 57 | 59 | 61 | 62 | 64 | 66 | 67 | 69 | 71 | 72 | 74 | 75 | 77 | 79 | 80 | 82 | 84 | 85 | 87 | 89 | 90 | 92 | 94 | 95 | 97 | 99 | | | | | |
| | 13 | 8 | 10 | 12 | 13 | 15 | 17 | 18 | 20 | 22 | 23 | 25 | 27 | 28 | 30 | 32 | 33 | 35 | 37 | 38 | 40 | 41 | 43 | 45 | 46 | 48 | 50 | 51 | 53 | 55 | 56 | 58 | 60 | 61 | 63 | 65 | 66 | 68 | 70 | 71 | 73 | 74 | 76 | 78 | 79 | 81 | 83 | 84 | 86 | 88 | 89 | 91 | 93 | 94 | 96 | 98 | 99 | | | | | |
| | 14 | 9 | 11 | 12 | 14 | 16 | 17 | 19 | 21 | 22 | 24 | 26 | 27 | 29 | 31 | 32 | 34 | 36 | 37 | 39 | 40 | 42 | 44 | 45 | 47 | 49 | 50 | 52 | 54 | 55 | 57 | 59 | 60 | 62 | 64 | 65 | 67 | 69 | 70 | 72 | 73 | 75 | 77 | 78 | 80 | 82 | 83 | 85 | 87 | 88 | 90 | 92 | 93 | 95 | 97 | 98 | 100 | | | | | |
| | 15 | 10 | 11 | 13 | 15 | 16 | 18 | 20 | 21 | 23 | 25 | 26 | 28 | 30 | 31 | 33 | 35 | 36 | 38 | 39 | 41 | 43 | 44 | 46 | 48 | 49 | 51 | 53 | 54 | 56 | 58 | 59 | 61 | 63 | 64 | 66 | 68 | 69 | 71 | 72 | 74 | 76 | 77 | 79 | 81 | 82 | 84 | 86 | 87 | 89 | 91 | 92 | 94 | 96 | 97 | 99 | | | | | | |
| | 16 | 10 | 12 | 14 | 15 | 17 | 19 | 20 | 22 | 24 | 25 | 27 | 29 | 30 | 32 | 34 | 35 | 37 | 38 | 40 | 42 | 43 | 45 | 47 | 48 | 50 | 52 | 53 | 55 | 57 | 58 | 60 | 62 | 63 | 65 | 67 | 68 | 70 | 71 | 73 | 75 | 76 | 78 | 80 | 81 | 83 | 85 | 86 | 88 | 90 | 91 | 93 | 95 | 96 | 98 | 100 | | | | | | |
| | 17 | 11 | 13 | 14 | 16 | 18 | 19 | 21 | 23 | 24 | 26 | 28 | 29 | 31 | 33 | 34 | 36 | 37 | 39 | 41 | 42 | 44 | 46 | 47 | 49 | 51 | 52 | 54 | 56 | 57 | 59 | 61 | 62 | 64 | 66 | 67 | 69 | 70 | 72 | 74 | 75 | 77 | 79 | 80 | 82 | 84 | 85 | 87 | 89 | 90 | 92 | 94 | 95 | 97 | 99 | | | | | | | |
| | 18 | 12 | 13 | 15 | 17 | 18 | 20 | 22 | 23 | 25 | 27 | 28 | 30 | 32 | 33 | 35 | 36 | 38 | 40 | 41 | 43 | 45 | 46 | 48 | 50 | 51 | 53 | 55 | 56 | 58 | 60 | 61 | 63 | 65 | 66 | 68 | 69 | 71 | 73 | 74 | 76 | 78 | 79 | 81 | 83 | 84 | 86 | 88 | 89 | 91 | 93 | 94 | 96 | 98 | 99 | | | | | | | |
| | 19 | 12 | 14 | 16 | 17 | 19 | 21 | 22 | 24 | 26 | 27 | 29 | 31 | 32 | 34 | 35 | 37 | 39 | 40 | 42 | 44 | 45 | 47 | 49 | 50 | 52 | 54 | 55 | 57 | 59 | 60 | 62 | 64 | 65 | 67 | 68 | 70 | 72 | 73 | 75 | 77 | 78 | 80 | 82 | 83 | 85 | 87 | 88 | 90 | 92 | 93 | 95 | 97 | 98 | 100 | | | | | | | |
| | 20 | 13 | 15 | 16 | 18 | 20 | 21 | 23 | 25 | 26 | 28 | 30 | 31 | 33 | 34 | 36 | 38 | 39 | 41 | 43 | 44 | 46 | 48 | 49 | 51 | 53 | 54 | 56 | 58 | 59 | 61 | 63 | 64 | 66 | 67 | 69 | 71 | 72 | 74 | 76 | 77 | 79 | 81 | 82 | 84 | 86 | 87 | 89 | 91 | 92 | 94 | 96 | 97 | 99 | | | | | | | | |
| | 21 | 14 | 15 | 17 | 19 | 20 | 22 | 24 | 25 | 27 | 29 | 30 | 32 | 33 | 35 | 37 | 38 | 40 | 42 | 43 | 45 | 47 | 48 | 50 | 52 | 53 | 55 | 57 | 58 | 60 | 62 | 63 | 65 | 66 | 68 | 70 | 71 | 73 | 75 | 76 | 78 | 80 | 81 | 83 | 85 | 86 | 88 | 90 | 91 | 93 | 95 | 96 | 98 | 99 | | | | | | | | |
| | 22 | 14 | 16 | 18 | 19 | 21 | 23 | 24 | 26 | 28 | 29 | 31 | 32 | 34 | 36 | 37 | 39 | 41 | 42 | 44 | 46 | 47 | 49 | 51 | 52 | 54 | 56 | 57 | 59 | 61 | 62 | 64 | 65 | 67 | 69 | 70 | 72 | 74 | 75 | 77 | 79 | 80 | 82 | 84 | 85 | 87 | 89 | 90 | 92 | 94 | 95 | 97 | 98 | | | | | | | | | |
| | 23 | 15 | 17 | 18 | 20 | 22 | 23 | 25 | 27 | 28 | 30 | 31 | 33 | 35 | 36 | 38 | 40 | 41 | 43 | 45 | 46 | 48 | 50 | 51 | 53 | 55 | 56 | 58 | 60 | 61 | 63 | 64 | 66 | 68 | 69 | 71 | 73 | 74 | 76 | 78 | 79 | 81 | 83 | 84 | 86 | 88 | 89 | 91 | 93 | 94 | 96 | 97 | 99 | | | | | | | | | |
| | 24 | 16 | 17 | 19 | 21 | 22 | 24 | 26 | 27 | 29 | 30 | 32 | 34 | 35 | 37 | 39 | 40 | 42 | 44 | 45 | 47 | 49 | 50 | 52 | 54 | 55 | 57 | 59 | 60 | 62 | 63 | 65 | 67 | 68 | 70 | 72 | 73 | 75 | 77 | 78 | 80 | 82 | 83 | 85 | 87 | 88 | 90 | 92 | 93 | 95 | 96 | 98 | 100 | | | | | | | | | |
| | 25 | 16 | 18 | 20 | 21 | 23 | 25 | 26 | 28 | 29 | 31 | 33 | 34 | 36 | 38 | 39 | 41 | 43 | 44 | 46 | 48 | 49 | 51 | 53 | 54 | 56 | 58 | 59 | 61 | 62 | 64 | 66 | 67 | 69 | 71 | 72 | 74 | 76 | 77 | 79 | 81 | 82 | 84 | 86 | 87 | 89 | 91 | 92 | 94 | 95 | 97 | 99 | | | | | | | | | | |
| | 26 | 17 | 19 | 20 | 22 | 24 | 25 | 27 | 28 | 30 | 32 | 33 | 35 | 37 | 38 | 40 | 42 | 43 | 45 | 47 | 48 | 50 | 52 | 53 | 55 | 57 | 58 | 60 | 61 | 63 | 65 | 66 | 68 | 70 | 71 | 73 | 75 | 76 | 78 | 80 | 81 | 83 | 85 | 86 | 88 | 90 | 91 | 93 | 94 | 96 | 98 | 99 | | | | | | | | | | |
| | 27 | 18 | 19 | 21 | 23 | 24 | 26 | 27 | 29 | 31 | 32 | 34 | 36 | 37 | 39 | 41 | 42 | 44 | 46 | 47 | 49 | 51 | 52 | 54 | 56 | 57 | 59 | 60 | 62 | 64 | 65 | 67 | 69 | 70 | 72 | 74 | 75 | 77 | 79 | 80 | 82 | 84 | 85 | 87 | 89 | 90 | 92 | 93 | 95 | 97 | 98 | | | | | | | | | | | |
| | 28 | 18 | 20 | 22 | 23 | 25 | 26 | 28 | 30 | 31 | 33 | 35 | 36 | 38 | 40 | 41 | 43 | 45 | 46 | 48 | 50 | 51 | 53 | 55 | 56 | 58 | 59 | 61 | 63 | 64 | 66 | 68 | 69 | 71 | 73 | 74 | 76 | 78 | 79 | 81 | 83 | 84 | 86 | 88 | 89 | 91 | 92 | 94 | 96 | 97 | 99 | | | | | | | | | | | |
| | 29 | 19 | 21 | 22 | 24 | 25 | 27 | 29 | 30 | 32 | 34 | 35 | 37 | 39 | 40 | 42 | | | | | | | | | | | | | | | | | | | | | | | | | | | | | | | | | | | | | | | | | | | | | | |

H. Clinical Investigation Conclusions

- When ThinPrep Integrated Imager is compared to ThinPrep Imaging System, reviewers achieved higher sensitivity in all abnormal categories. There was some decrease in specificity.
 - For ASCUS+ slides, the increase of sensitivity was 3.8% with 95% confidence interval of 2.6% to 5.0% and a decrease of specificity was -1.9% with 95% confidence interval of -2.8% to -1.0%.
 - For LSIL+ slides, the increase in sensitivity was 5.8% with 95% confidence interval of 4.1% to 7.5% and a decrease of specificity was -1.9% with a 95% confidence interval of -2.6 to -1.2%
 - For HSIL+ the increase in sensitivity was 7.9% with a 95% confidence interval of 4.5% to 11.2% and a decrease in specificity of -1.1% with a 95% confidence interval of -1.6% to -0.6%.
- Considering the technological similarity of the ThinPrep Imaging System and the comparative clinical study results, it is concluded that the ThinPrep Integrated Imager is similar to the ThinPrep Imaging System and may be used as replacement for manual review of ThinPrep® Pap Test slides prepared on the ThinPrep 2000 System and the ThinPrep 5000 processor for the presence of atypical cells, cervical neoplasia, including its precursor lesions (Low Grade Squamous Intraepithelial Lesions, High Grade Squamous Intraepithelial Lesions), and carcinoma as well as all other cytological criteria as defined by the Bethesda System.
- The screening volume for the CTs when using the Integrated Imager for the imaging and review of slides is within the Clinical Laboratory Improvement Amendments (CLIA) guidelines for total number of slides that can be screened in one day.
- In order to increase the number of slides that can be reviewed by a Cytotechnologist in one day, slides can be imaged in advance (in batched modality) and then reviewed by the CT in a batch.
- The number of slides that a Cytotechnologist can scan and review in one day is less on the Integrated Imager than the ThinPrep Imaging System.
 - Performance may vary from site to site as a result of differences in patient populations and reading practices. As a result each laboratory using this device should employ quality assurance and control systems to ensure proper use and selection of appropriate workload limits.
 - For these clinical sites and these study populations, the data from the clinical trial demonstrate that the use of the ThinPrep Integrated Imager to assist in primary cervical cancer screening of ThinPrep® Pap Test slides for the presence of atypical cells, cervical neoplasia, including its precursor lesions, and carcinoma as well as all other cytological criteria as defined by the Bethesda System, is safe and effective for the detection of cervical abnormalities.

I. Bibliography

1. Nayar R, Wilbur DC. (eds). *The Bethesda System for Reporting Cervical Cytology: Definitions, Criteria, and Explanatory Notes*. 3rd ed. Cham, Switzerland: Springer: 2015
2. Hologic, Inc. *ThinPrep® Imaging System Operation Summary and Clinical Information*. Part number MAN-03938-001.