



EverFlex™

Self-expanding Peripheral Stent System

Protégé™ EverFlex™

Self-expanding Biliary Stent System

INSTRUCTIONS FOR USE

SFA and ILIAC INDICATIONS

DEVICE DESCRIPTION

The EverFlex™ self-expanding peripheral stent system (EverFlex stent) is a self-expanding Nitinol stent system intended for permanent implantation. The self-expanding stent is made of a nickel titanium alloy (Nitinol) and comes pre-mounted on a 6 F, 0.035" over-the-wire delivery system. The stent is cut from a Nitinol tube in an open lattice design, and has tantalum radiopaque markers at the proximal and distal ends of the stent. Upon deployment, the stent achieves its predetermined diameter and exerts a constant, gentle outward force to establish patency.

The delivery system, as shown in **Figure 1, 1a, and 1b**, includes an inner subassembly (1) and outer subassembly (2), which are locked together with a safety lock (3). The inner subassembly terminates distally in a flexible catheter tip (4) and originates proximally at the hub (5).

The distal portion of the delivery system for the 20 – 150 mm stents, as shown in **Figure 1a**, is comprised of two radiopaque markers, one marker distal (6) and one marker/retainer proximal (7) to the stent, on the inner subassembly.

The distal portion of the delivery system for the 200 mm stents, as shown in **Figure 1b**, includes the same components as those in **Figure 1a** except for the radiopaque markers: one marker/retainer distal (13) and one marker/holder proximal (14) to the stent, on the inner subassembly.

The outer sheath connects proximally to the manifold subassembly (8). The self-expanding stent is constrained within the space between the inner and outer sub-assemblies. This space is flushed prior to the procedure through the stopcock (9). The outer subassembly has a radiopaque marker at its distal end (10).

The stent is positioned at the target lesion using the two radiopaque markers on the inner subassembly and the radiopaque markers on the stent.

For stent deployment, turn the safety lock counterclockwise to unlock the outer subassembly. The outer subassembly retracts by pulling the distal grip (11) toward the proximal grip (12). Stent deployment is complete when the radiopaque marker on the outer subassembly passes the proximal radiopaque marker on the inner subassembly.

Refer to **Table 1** for sizing information.

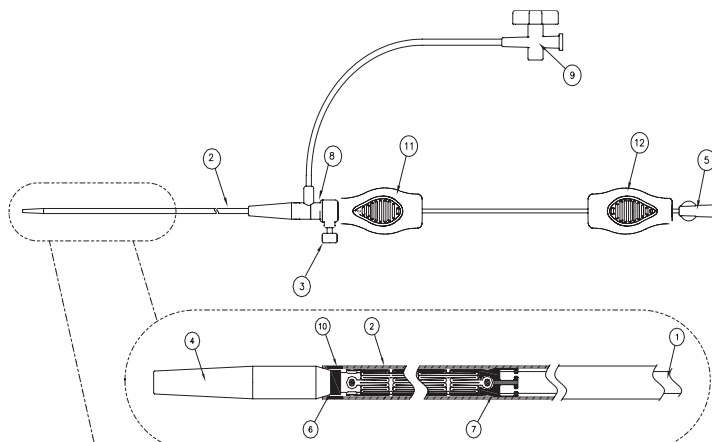

Figure 1a: Distal Portion of 20 - 150 mm Delivery System

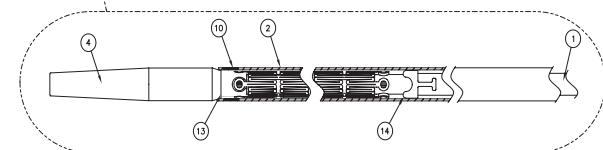

Figure 1b: Distal Portion of 200 mm Delivery System

Figure 1: Delivery System

1. Inner Subassembly
2. Outer Subassembly
3. Safety Lock
4. Distal Catheter Tip
5. Proximal Hub
6. Inner Subassembly Distal Marker Band
7. Inner Subassembly Proximal Marker Band/Retainer
8. Manifold Subassembly
9. Stopcock
10. Outer Subassembly Distal Marker Band
11. Distal Grip
12. Proximal Grip
13. Inner Subassembly Distal Marker Band/Retainer
14. Inner Subassembly Proximal Marker/Holder Retainer

INDICATIONS FOR USE - SFA

The EverFlex™ self-expanding peripheral stent system is intended to improve luminal diameter in the treatment of symptomatic *de novo* or restenotic lesions up to 180 mm in length in the native Superficial Femoral Artery (SFA) and/or proximal popliteal arteries with reference vessel diameters ranging from 4.5 – 7.5 mm.

INDICATIONS FOR USE - ILIAC

The EverFlex™ self-expanding peripheral stent system is indicated for improving luminal diameter in patients with atherosclerotic disease of the common and/or external iliac arteries up to and including 100 mm in length, with a reference vessel diameter of 4.5 – 7.5 mm.

CONTRAINDICATIONS

- Patients in whom anticoagulant and/or antiplatelet therapy is contraindicated.
- Patients with known hypersensitivity to nickel titanium.
- Patients who are judged to have a lesion that prevents complete inflation of an angioplasty balloon or proper placement of the stent or stent delivery system.

WARNINGS

- The device is provided STERILE for single use only. Do not reprocess or resterilize. Reprocessing and resterilizing could increase the risk of patient infection and risk of compromised device performance.
- If resistance is encountered at any time during the insertion procedure, do not force passage. Resistance may cause damage to stent or vessel. Carefully withdraw the stent system without deploying the stent.
- If resistance is felt when initially pulling back on the distal grip, do not force deployment. Carefully withdraw the stent system without deploying the stent.
- If resistance is met during delivery system withdrawal, advance the outer subassembly until the outer subassembly marker contacts the catheter tip and withdraw the system as one unit.

PRECAUTIONS

- Carefully inspect the sterile package and device prior to use to verify that no damage occurred during shipment.
- Do not exceed 300 psi / 20 ATM while flushing the delivery system.
- Do not use if the stent is partially deployed upon removal from the package, or before starting the deployment procedure.
- Support from a sheath is necessary to minimize lengthening or shortening during stent deployment.
- Always use a sheath during the implant procedure to protect both the vessel and puncture site.
- Failure to pre-dilate the lesion may impair the ability to remove the stent system after stent deployment.
- The stent system is not designed for recapturing or repositioning after establishing vessel apposition.
- Failure to hold the proximal grip in a fixed position may result in partial deployment, foreshortening, lengthening or increased deployment force.
- The stent is not designed to be lengthened or shortened past its nominal length. Excessive stent lengthening or shortening may increase the risk of stent fracture.
- Use caution when crossing a deployed stent with any adjunct device.
- Stent should not be expanded past its nominal diameter.

Table 1: Sizing Chart

Vessel Sizing for SFA Stents					
Device Diameter (mm)	Recommended Vessel Diameter (mm)	Introducer Sheath Size (Fr)	Guidewire Compatibility	Device Lengths (mm)	Catheter Lengths (cm)
6	4.5 - 5.5	6	0.035"	20, 40, 60, 80, 100, 120, 150, 200	80, 120
7	5.5 - 6.5	6	0.035"	20, 40, 60, 80, 100, 120, 150, 200	80, 120
8	6.5 - 7.5	6	0.035"	20, 40, 60, 80, 100, 120, 150, 200	80, 120
Vessel Sizing for Iliac Stents					
Device Diameter (mm)	Recommended Vessel Diameter (mm)	Introducer Sheath Size (Fr)	Guidewire Compatibility	Device Lengths (mm)	Catheter Lengths (cm)
6	4.5 - 5.5	6	0.035"	20, 40, 60, 80, 100, 120	80, 120
7	5.5 - 6.5	6	0.035"	20, 40, 60, 80, 100, 120	80, 120
8	6.5 - 7.5	6	0.035"	20, 40, 60, 80, 100, 120	80, 120
Duct Sizing for Biliary Stents					
Device Diameter (mm)	Recommended Duct Diameter (mm)	Introducer Sheath Size (Fr)	Guidewire Compatibility	Device Lengths (mm)	Catheter Lengths (cm)
5	3.5 - 4.5	6	0.035"	20, 40, 60, 80, 100, 120	80, 120
6	4.5 - 5.5	6	0.035"	20, 40, 60, 80, 100, 120, 150	80, 120
7	5.5 - 6.5	6	0.035"	20, 40, 60, 80, 100, 120, 150	80, 120
8	6.5 - 7.5	6	0.035"	20, 40, 60, 80, 100, 120, 150	80, 120

Table 2: Stent Foreshortening

Stent Diameter (mm)	Average
6	0 - 6%
7	0 - 6%
8	1 - 6%

SFA INDICATION

ADVERSE EVENTS

The EverFlex™ self-expanding peripheral stent system was evaluated in a study titled the US StuDy for Evaluating Endovascular Treatments of Lesions in the Superficial Femoral Artery and Proximal Popliteal By using the EverFlex Nitinol Stent System II (DURABILITY II). A total of 287 subjects were enrolled. The primary objective was to evaluate the safety and effectiveness of primary stenting using the EverFlex self-expanding stent system compared to percutaneous transluminal angioplasty (PTA) performance goals for the treatment of stenotic, restenotic or occluded lesions (non-stented) of the native superficial femoral artery or the superficial femoral and proximal popliteal arteries.

Table 3 provides a summary of the adverse events (AE) documented in the DURABILITY II study. The data are presented as a percentage of subjects experiencing an AE followed by the total number of events in brackets.

POTENTIAL ADVERSE EVENTS

The potential adverse effects (e.g., complications) that may occur and/or require intervention with the use of this device include, but are not limited to:

- Abrupt or sub-acute closure
- Allergic reaction to device materials or procedure medications
- Allergic reaction to Nitinol
- Amputation
- Aneurysm
- Angina
- Arrhythmia
- Arterio-venous fistula
- Artery injury (e.g., dissection, perforation, or rupture)
- Bleeding requiring transfusion
- Bruising
- Contrast medium reaction/renal failure
- Death
- Device breakage
- Edema
- Embolism
- Failure to deploy stent
- Fever
- Gastrointestinal bleeding due to anticoagulation
- Hematoma
- Hypertension/hypotension
- Infection
- Inflammation
- Intraluminal thrombus
- Myocardial infarction
- Pain
- Partial stent deployment
- Pseudoaneurysm
- Renal failure
- Renal insufficiency
- Restenosis
- Sepsis
- Shock
- Stent collapse or fracture
- Stent migration
- Stent misplacement
- Stroke
- Surgical or endovascular intervention
- Thrombosis/occlusion of the stent
- Transient ischemic attack
- Venous thromboembolism
- Vessel spasm
- Worsening claudication or rest pain

Table 3: Summary of Adverse Events

Adverse Event	Events at ≤ 30 days % (n/N) [Events]	Events at ≤ 1 Year % (n/N) [Events]	Events at ≤ 2 Year % (n/N) [Events]	Events at ≤ 3 Year % (n/N) [Events]	Total Events
Total Subjects with AEs*	47.0% (134/285) [223]	88.3% (248/281) [860]	93.2% (262/281) [1365]	97.2% (273/281) [1900]	95.5% (274/287) [1966]
Access site complication	4.9% (14/285) [14]	5.0% (14/281) [14]	5.3% (15/281) [15]	6.0% (17/281) [17]	5.9% (17/287) [17]
Acute stent thrombosis	-	2.1% (6/281) [7]	2.1% (6/281) [8]	2.1% (6/281) [8]	2.1% (6/287) [8]
Allergic reaction	1.4% (4/285) [4]	1.8% (5/281) [5]	1.8% (5/281) [5]	1.8% (5/281) [5]	1.7% (5/287) [5]
Amputation of treated limb	0.4% (1/285) [1]	0.4% (1/281) [1]	1.1% (3/281) [3]	1.1% (3/281) [4]	1.0% (3/287) [4]
Amputation of untreated limb	-	0.4% (1/281) [1]	0.4% (1/281) [1]	0.4% (1/281) [1]	0.3% (1/287) [1]
Angina	0.4% (1/285) [1]	4.3% (12/281) [13]	7.5% (21/281) [23]	9.3% (26/281) [31]	9.4% (27/287) [32]
Arrhythmia	0.7% (2/285) [2]	2.1% (6/281) [7]	3.9% (11/281) [12]	5.3% (15/281) [16]	5.2% (15/287) [16]
Artery perforation	1.8% (5/285) [8]	1.8% (5/281) [8]	1.8% (5/281) [8]	1.8% (5/281) [8]	1.7% (5/287) [8]
Cerebrovascular accident	-	1.8% (5/281) [5]	3.2% (9/281) [9]	5.0% (14/281) [14]	4.9% (14/287) [14]
Death**	-	1.1% (3/281) [3]	2.5% (7/281) [7]	2.5% (7/281) [7]	2.4% (7/287) [7]
Dissection	13.3% (38/285) [40]	14.6% (41/281) [47]	14.9% (42/281) [50]	15.3% (43/281) [52]	15.3% (44/287) [53]
Edema	1.8% (5/285) [5]	5.3% (15/281) [15]	7.5% (21/281) [25]	10.0% (28/281) [34]	9.8% (28/287) [34]
GI bleeding	0.4% (1/285) [1]	1.4% (4/281) [4]	2.8% (8/281) [8]	3.6% (10/281) [10]	3.5% (10/287) [10]
Hyper/hypotension	1.8% (5/285) [5]	4.3% (12/281) [12]	5.0% (14/281) [16]	6.8% (19/281) [21]	6.6% (19/287) [21]
Myocardial infarction	-	1.1% (3/281) [3]	2.5% (7/281) [7]	2.8% (8/281) [8]	2.8% (8/287) [8]
Other bleeding/lymphatic system disorders	1.1% (3/285) [3]	4.3% (12/281) [13]	6.8% (19/281) [22]	7.5% (21/281) [25]	7.3% (21/287) [26]
Other cardiac disorders	1.1% (3/285) [3]	9.6% (27/281) [31]	14.9% (42/281) [56]	21.4% (60/281) [95]	20.9% (60/287) [95]
Other GU disorders	0.7% (2/285) [2]	5.0% (14/281) [17]	7.5% (21/281) [33]	11.7% (33/281) [51]	11.8% (34/287) [52]
Other gastrointestinal disorders	3.5% (10/285) [12]	13.9% (39/281) [59]	17.4% (49/281) [85]	22.1% (62/281) [107]	22.0% (63/287) [110]
Other infections	0.4% (1/285) [1]	3.9% (11/281) [12]	6.4% (18/281) [23]	12.1% (34/281) [48]	12.2% (35/287) [50]
Other musculoskeletal disorders	4.9% (14/285) [16]	19.2% (54/281) [72]	29.5% (83/281) [121]	37.0% (104/281) [176]	36.6% (105/287) [182]
Other respiratory issues	0.4% (1/285) [1]	11.4% (32/281) [39]	18.1% (51/281) [72]	22.8% (64/281) [112]	22.6% (65/287) [113]
Other vascular disorders	5.3% (15/285) [16]	20.6% (58/281) [78]	32.4% (91/281) [134]	43.4% (122/281) [221]	44.6% (128/287) [236]
Percutaneous revascularization of non target vessel	-	3.6% (10/281) [11]	3.6% (10/281) [13]	3.6% (10/281) [14]	3.5% (10/287) [14]
Percutaneous revascularization of target vessel	0.4% (1/285) [1]	0.7% (2/281) [2]	0.7% (2/281) [2]	1.1% (3/281) [3]	1.0% (3/287) [3]
Renal failure	-	1.1% (3/281) [3]	1.4% (4/281) [4]	2.5% (7/281) [7]	2.4% (7/287) [7]
Renal insufficiency	-	-	0.4% (1/281) [1]	1.1% (3/281) [3]	1.0% (3/287) [3]
Restenosis	0.7% (2/285) [2]	24.6% (69/281) [75]	36.3% (102/281) [134]	43.1% (121/281) [177]	43.2% (124/287) [189]
Stent malposition/migration	0.4% (1/285) [1]	0.4% (1/281) [1]	0.4% (1/281) [1]	0.4% (1/281) [1]	0.3% (1/287) [1]
Stent/Vessel thrombosis	0.4% (1/285) [1]	1.1% (3/281) [3]	1.8% (5/281) [5]	2.1% (6/281) [6]	2.1% (6/287) [6]
Vessel flow complication	0.4% (1/285) [1]	0.4% (1/281) [1]	0.7% (2/281) [2]	1.1% (3/281) [3]	1.0% (3/287) [3]
Other	21.4% (61/285) [82]	50.9% (143/281) [298]	62.3% (175/281) [460]	68.3% (192/281) [615]	67.6% (194/287) [638]

* The denominators in each column represent the number of subjects with adverse events for the reported time period (285 subjects at ≤30 days; 281 subjects at ≤1 year; 287 total subjects, etc).

** Count of AEs labeled "death" is less than total number of study deaths since death may be attributable to other AEs.

CLINICAL STUDIES

DURABILITY II

The US StuDy for Evaluating Endovascular Treatments of Lesions in the Superficial Femoral Artery and Proximal Popliteal By using the EverFlex Nitinol Stent System II (DURABILITY II) study was a prospective, multi-center, non-randomized, single arm study. DURABILITY II compared percutaneous transluminal angioplasty (PTA) and primary stenting with the EverFlex™ stent to performance goals of PTA alone in the treatment of atherosclerotic lesions of the native superficial femoral artery (SFA) or the superficial femoral and proximal popliteal arteries. The safety and effectiveness performance goals were based on an aggregate of published trial data as described by VIVA Physicians Inc. (VPI)^{1,2}. DURABILITY II was conducted at 40 US and four European investigational sites. A total of 287 subjects were enrolled. Eligible subjects either had stenotic, restenotic (non-stented) or occluded lesions. The reference vessel diameter of the treated subjects was to be 4.5 - 7.5 mm and the lesion length from 4 - 18 cm long. Subjects had to have Rutherford Clinical Categories of 2 - 4. Subject follow-up occurred at 30 days, 6 months, 1, 2, and 3 years post-procedure. The primary safety endpoint for the study was Major Adverse Event (MAE) rate at 30 days and the primary effectiveness endpoint was primary stent patency rate at 1 year.

¹ Rocha-Singh KJ. Proposed Performance Goals for Single-Arm Clinical Trials of Bare Nitinol Stents in the Femoral Popliteal Artery. *Vascular Interventional Advances*. Las Vegas, NV2006.

² Rocha-Singh KJ, Jaff MR, Crabtree TR, Bloch DA, Ansel G. Performance goals and endpoint assessments for clinical trials of femoropopliteal bare nitinol stents in patients with symptomatic peripheral arterial disease. *Catheter Cardiovasc Interv*. May 1 2007;69(6):910-919.

SUBJECT ELIGIBILITY CRITERIA

Subjects with stenosis of the native superficial femoral artery or the superficial femoral and proximal popliteal arteries, who consented to participate, were eligible for inclusion in the DURABILITY II study. To be included, they had to be at least 18 years old.

SUBJECT FOLLOW-UP

Table 4 summarizes subject follow-up compliance in the DURABILITY II study. Percentages are based on subjects expected for each follow-up visit. Subjects expected for each follow-up visit included those who had completed the visit and those who had not completed the visit but for whom the visit window had closed.

Table 4: Summary of Subject Compliance

Time	Compliance
Pre-discharge	100% (287/287)
30 Days	97% (279/287)
6 Months	96% (275/287)
1 Year	92% (265/287)
2 Year	81% (232/287)
3 Year	77% (220/287)

SFA INDICATION (continued)

Baseline demographics and clinical characteristics are presented in **Table 5**.

Table 5: Demographics and Baseline Clinical Characteristics

Subject Characteristics	N=287
Age (yrs.)	
Mean ± SD (N)	67.7 ± 10.7 (287)
Range (min, max)	(39.4, 93.3)
Male	66.2% (190/287)
Race	
White/Caucasian	88.9% (255/287)
African	7.7% (22/287)
Asian	0.7% (2/287)
Hispanic	2.4% (7/287)
Other	0.3% (1/287)
Risk Factors	
Diabetes	42.9% (123/287)
Type I	3.1% (9/287)
Type II	39.7% (114/287)
Hyperlipidemia	86.1% (247/287)
Hypertension	88.2% (253/287)
Renal Insufficiency	9.8% (28/287)
Current smoker	39.0% (112/287)
Medical History	
Angina	17.4% (50/287)
Arrhythmia	14.6% (42/287)
Congestive heart failure (CHF)	9.8% (28/287)
Stroke	6.6% (19/287)
Transient ischemic attack (TIA)	4.9% (14/287)
Myocardial Infarction	20.9% (60/287)
Non-healing ischemic ulcer in the lower extremities	1.4% (4/287)
Amputation of the lower extremities	1.0% (3/287)
Previous Interventions in the superficial femoral arteries or popliteal	41.1% (118/287)
Clinical Characteristics	
Rutherford Clinical Category	
2=Moderate claudication	39.4% (113/287)
3=Severe claudication	55.7% (160/287)
4=Ischemic rest pain	4.5% (13/287)
5=Minor tissue loss	0.3% (1/287)
Ankle Brachial Index	
Mean ± SD (N)	0.69 ± 0.19 (281*)
Range (min, max)	(0.06, 1.38)
*ABI not available for 6 subjects due to non-compressible arteries.	

Table 6 presents baseline characteristics (assessed by the angiographic core laboratory except as otherwise noted), including lesion location, length and pre-procedure vessel diameter.

Per site assessment, normal-to-normal lesion was determined by measuring the length of the target lesion from healthy tissue to healthy tissue. In contrast, 20-to-20 lesion length was determined by measuring between the proximal and distal points at which the lesion was 20% stenosed by the angiographic core laboratory. The mean lesion length was 109.6 mm by the normal-to-normal method and 89.1 mm by the 20-to-20 method.

Table 6: Angiographic Core Laboratory-Reported Baseline Target Lesion Characteristics

Lesion Characteristics	N=287
SFA Location	
Superior SFA	27.5% (79/287)
Inferior SFA	70.4% (202/287)
Popliteal	2.1% (6/287)
Lesion length (mm) (Normal-to-Normal method)*	
Mean ± SD (N)	109.6 ± 45.0 (287)
Range (min, max)	(10.0, 180.0)
Lesion Length (mm) (20-to-20 method)	
Mean ± SD (N)	89.1 ± 44.8 (287)
Range (min, max)	(7.3, 200.9)
Pre-procedure Reference Vessel Diameter (mm)	
Mean ± SD (N)	4.8 ± 0.9 (287)
Range (min, max)	(2.7, 8.0)
Pre-procedure Minimum Lumen Diameter (mm)	
Mean ± SD (N)	0.7 ± 0.8 (287)
Range (min, max)	(0.0, 2.7)
Pre-procedure Diameter Stenosis (%)	
Mean ± SD (N)	85.8 ± 16.2 (287)
Range (min, max)	(50.7, 100.0)
Occlusion	48.1% (138/287)
Bend	100% (287/287)
Calcification	
None/Mild	30.0% (86/287)
Moderate	26.8% (77/287)
Severe	43.2% (124/287)
Ulcerated	10.5% (30/287)
Aneurysm	1.0% (3/287)

*Normal-to-normal lesion length assessed per site investigator

CLINICAL RESULTS

The primary effectiveness analysis was specified to occur using the first 232 single-stent subjects. Because the primary safety analysis was pre-specified to occur using all 287 enrolled subjects, safety and effectiveness data from the 287-patient Intent-to-Treat cohort using the same endpoints and definitions were also available. Because this larger analysis yielded similar results as the analysis of the first 232 single-stent subjects, the results of the analysis of the full cohort are presented.

Primary Safety Endpoint

The primary safety endpoint was the major adverse event rate at 30 days. MAE was defined as clinically-driven target lesion revascularization (TLR), amputation of treated limb, or all-cause mortality, as adjudicated by the Clinical Event Committee (CEC).

The 30 day MAE rate was 0% (**Table 7**). The 97.5% upper confidence bound was 1.1% (as calculated by the Exact method), which is less than the performance goal (PG) of 12%.

Table 7: Summary of Primary Safety Endpoint

MAE within 30 Days	N= 284*	97.5% Upper Confidence Bound	Performance Goal	Objective Met
Subjects with MAE within 30 Days	0.0% (0/284) [0]	1.1%	12%	Yes
Death	0.0% (0/284) [0]	-	-	-
Amputation of treated limb	0.0% (0/284) [0]	-	-	-
Clinically-driven TLR	0.0% (0/284) [0]	-	-	-

*The denominator included subjects who had completed the 30-day follow-up visit (N=280) and those who did not complete the 30-day visit but came back for later follow up visits (N=4). Three (3) subjects with no reported MAEs prior to 30 days, who did not complete the 30-day visit, and were without any further follow-up information were not included in the analysis.

SFA INDICATION (continued)

Primary Effectiveness Endpoint

The primary effectiveness endpoint was primary stent patency, defined as Peak Systolic Velocity (PSV) ratio < 2.0 at the stented target lesion with no clinically-driven reintervention within the stented segment as measured at the 1-year follow-up day. Primary stent patency was evaluated in all enrolled subjects with evaluable 1-year data (N=227, excluding out-of-window duplexes) and was achieved in 67.8% (154/227) of the subjects (Table 8). The 97.5% lower confidence bound of 61.3% is greater than the PG of 57%. Therefore, the primary effectiveness endpoint was met and the null hypothesis is rejected.

In twenty-seven (27) subjects, the 1-year duplex data were evaluable but obtained out of the 1-year follow-up visit window. If the 27 subjects with out-of-window duplexes were included in the analysis, the primary stent patency would be achieved in 68.5% (174/254) of the subjects.

Table 8: Summary of Primary Effectiveness Endpoint

Primary Effectiveness Endpoint	Primary Stent Patency Rate	97.5% Lower Confidence Bound	Performance Goal	Objective Met?
Single-stent & multi-stent subjects (Exclude Out-of-Window Duplex)	67.8% (154/227)	61.3%	57.0%	Yes
Single-stent & multi-stent subjects (Include Out-of-Window Duplex)	68.5% (174/254)	62.4%	57.0%	Yes

The primary stent patency rate was also analyzed using the Kaplan-Meier method. The analysis cohort consisted of all enrolled subjects.

As presented in Figure 2 and Table 9, the freedom from loss of primary patency (PSV < 2.0 and no clinically-driven reintervention within the stented segment) at 1 year was 77.9%.

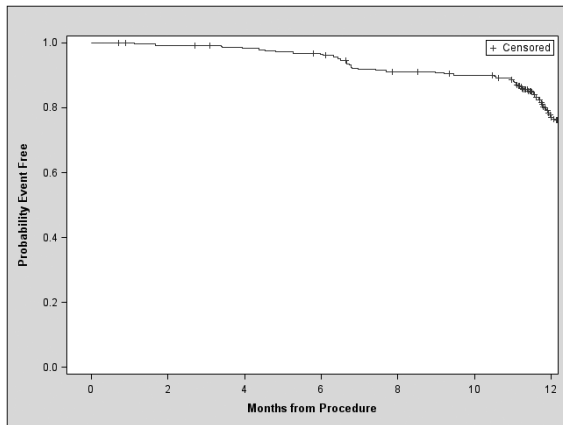

Figure 2: Freedom from Loss of Primary Patency through 1 Year

Table 9: Probability of Freedom from Loss of Primary Patency through 1 Year

Month	# At Risk	Cumulative # Events	Cumulative Censored	Probability Event Free	95% CI
0	287	0	0	100%	-
1	285	0	2	100%	-
6	272	0	6	96.8%	94.0%-98.3%
12	181	61	16	77.9%	72.5%-82.4%

Table 10 provides stent patency at 1-year broken out by lesion length, as assessed by the Corelab.

Table 10: Primary Stent Patency at 1 Year by Lesion Length as Assessed by Corelab

Primary Stent Patency at 1 Year	Lesion Length 0-150 mm	Lesion Length >150-180 mm	Lesion Length >180 mm
Protocol defined primary analysis	71.4% (145/203)	50% (8/16)	12.5% (1/8)
Kaplan-Meier analysis of freedom from loss of primary patency	81.1%	65.0%	13.9%

DURABILITY II 3-YEAR RESULTS

Major Adverse Events

Major adverse events were collected through 3-year follow-up. A MAE was defined as clinically-driven TLR, amputation of treated limb, and all-cause mortality, as adjudicated by the CEC. The 1-year MAE rate was 17.2% (47/273), the 2-year MAE rate was 33.0% (86/261), and the 3-year MAE rate was 40.9%. Table 11 presents details of MAEs through 3 years.

Table 11: Major Adverse Event Rate at 1, 2, and 3 Years

Major Adverse Event	MAE at ≤ 30 Days % (n/N) [Events]	MAE at ≤ 1 Year % (n/N) [Events]	MAE at ≤ 2 Year % (n/N) [Events]	MAE at ≤ 3 Year % (n/N) [Events]
Major Adverse Event	0.0% (0/284) [0]	17.2% (47/273) [51]	33.0% (86/261) [103]	40.9% (105/257) [135]
Death	0.0% (0/284) [0]	2.9% (8/273) [8]	7.7% (20/261) [20]	10.1% (26/257) [26]
Amputation of treated limb	0.0% (0/284) [0]	0.0% (0/273) [0]	0.4% (1/261) [1]	0.8% (2/257) [2]
Clinically driven TLR	0.0% (0/284) [0]	14.3% (39/273) [43]	25.7% (67/261) [82]	31.1% (80/257) [107]

Primary Stent Patency

Primary stent patency rate was also analyzed through 3 years (Table 12). Primary stent patency was defined binary duplex ultrasound ratio < 2.0 at the stented target lesion with no clinically-driven reintervention within the stented segment. The analysis cohort consisted of all enrolled subjects.

Table 12: Primary Patency through 3 Years

Primary Stent Patency	1 Year	2 Year	3 Year
Single-stent & multi-stent subjects (Exclude Out-of-Window Duplex)	67.8% (154/227)	56.5% (121/214)	52.5% (114/217)
Single-stent & multi-stent subjects (Include Out-of-Window Duplex)	68.5% (174/254)	57.5% (130/226)	53.9% (124/230)

The primary stent patency rate was also analyzed using the Kaplan-Meier method. As shown in Figure 3 and Table 13, the freedom from loss of primary patency (PSV ratio < 2.0 and no clinically-driven reintervention within the stented segment) at 1 year was 77.9%, 66.1% at two years, and 60.0% at three years.

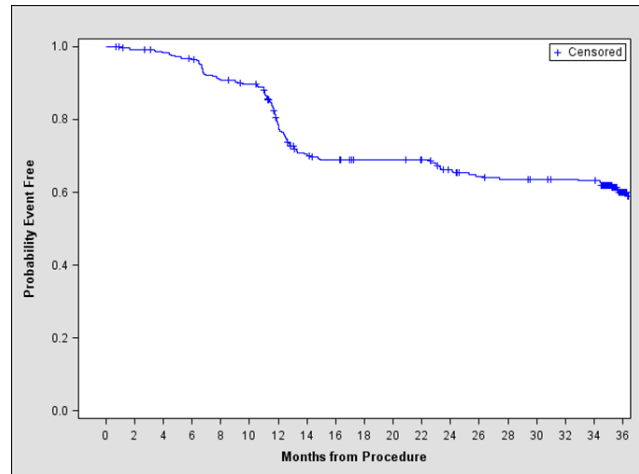

Figure 3: Freedom from Loss of Primary Patency through 3 Years

SFA INDICATION (continued)

Table 13: Probability of Freedom from Loss of Primary Patency through 3 Years

Month	# At Risk	Cumulative # Events	Cumulative Censored	Probability Event Free	95% CI
0	287	0	0	100%	-
1	285	0	2	100%	-
6	272	9	6	96.8%	94.0%-98.3%
12	210	61	16	77.9%	72.5%-82.4%
24	161	92	34	66.1%	60.1%-71.4%
36	72	105	110	60.0%	53.7%-65.8%

Stent fractures were evaluated through 3 years of follow-up. X-rays on 263 stents (251 subjects) at 1 year, 226 stents (214 subjects) at 2 years, and 217 stents (207 subjects) at 3 years were available for analysis by the core laboratory for stent fractures. Stent fractures identified by the core laboratory were evaluated and classified by the Stent Fracture Adjudication Committee. (Table 14).

Table 14: Stent Fracture through 3 Years³

Stent Fracture	1 Year	2 Year	3 Year
Stent Fracture	0.4% (1/263)	0.9% (2/226)	0.9% (2/217)
Class I - One strut fracture	0.0% (0/263)	0.0% (0/226)	0.0% (0/217)
Class II - Multiple strut fracture	0.0% (0/263)	0.0% (0/226)	0.0% (0/217)
Class III - Complete linear horizontal fracture without displacement	0.0% (0/263)	0.4% (1/226)	0.5% (1/217)
Class IV - Complete linear horizontal fracture with displacement	0.0% (0/263)	0.0% (0/226)	0.0% (0/217)
Class V - Trans-axial spiral fracture with displacement	0.4% (1/263)	0.4% (1/226)	0.5% (1/217)

The DURABILITY II Post Approval Plan was implemented as a condition of approval for the DURABILITY II PMA. The DURABILITY II Post Approval Plan analyzed subjects enrolled in the DURABILITY II Study with evaluable data out to 3 years. The follow-up compliance rate through 3 years (Table 4), baseline demographics and clinical characteristics (Table 5) for the DURABILITY II cohort have been described.

The subject data analyzed in the Post Approval Plan were the same as those in the DURABILITY II study, although some study endpoints were defined and analyzed differently. The primary objective of the Post Approval Plan was to confirm the long-term safety and effectiveness of the EverFlex™ stent through 3 years post-procedure. The primary endpoint was a composite defined as freedom from acute death, 36-month amputation, and 36-month clinically-driven TLR. Secondary endpoints included freedom from stent fracture at 1, 2, and 3 years and adverse event rates through 3 years.

As shown in Table 15, the primary composite endpoint of the DURABILITY II Post Approval Plan was freedom from acute death, amputation, and TLR at 36 months and was analyzed using the Kaplan-Meier method. The composite endpoint for the DURABILITY II Post Approval Plan was 69.7% with a lower 97.5% confidence interval of 63.7%. The study endpoint was met.

Table 15: Primary Endpoint Freedom from Acute Death, Amputation and TLR at 36 Months

Primary Endpoint	Freedom from Primary Endpoint	97.5% Lower Confidence Limit	Performance Goal	Objective Met
Freedom From Primary Endpoint	69.7%	63.7%	35.0%	Yes

Strengths and Weaknesses of the DURABILITY II Study

DURABILITY II was a prospective, multi-center, single-arm study that enrolled a robust number of subjects and had a high follow-up compliance rate through three years. The study included independent oversight of the safety and effectiveness outcomes. A Clinical Events Committee (CEC) and a Data Safety Monitoring Board (DSMB) reviewed the safety data. Independent angiographic, radiographic, and duplex ultrasound core laboratories analyzed procedural and follow-up images. One of the limitations was a lack of a control direct comparison.

Supplemental Clinical Information

DURABILITY I⁴ (Study Measuring the Durability of the PROTÉGÉ™ EverFlex™ stent in Lesions of the Superficial Femoral Artery), was a multi-center, non-randomized, prospective study. It was designed to evaluate the safety and efficacy of the EverFlex stent in the treatment of *de novo*, restenotic or reoccluded SFA lesions in symptomatic PAD patients. The study enrolled 151 subjects (151 target lesions) between August 2006 and June 2007 at 13 centers in Europe. Technical success was achieved in all patients. The primary patency (defined as PSVR < 2.5) rate at 12 months was 72.2%. The target lesion revascularization rate was 20.9% at 12 months. The secondary patency rate at 12 months was 89.1% (115/129). Stent fractures were found in 10 of 123 subjects with available x-ray data, resulting in a 12-month stent fracture rate of 8.1%. Elongation of the EverFlex stent during implantation was identified in 90% (9/10) of the fractured stents at 12 months. An improvement of Rutherford classification was achieved in 91.8% (123/134) of patients at 12 months.

³ Jaff M, Dake M, Pompa J, Ansel G, Yoder T. Standardized evaluation and reporting of stent fractures in clinical trials of noncoronary devices. *Catheter Cardiovasc Interv*. Sep 2007;70(3):460-462.

⁴ Bosiers M, Torsello et al. Nitinol Stent Implantation in Long Superficial Femoral Artery Lesions: 12-Month Results of the DURABILITY I Study. *J Endovas Ther* 2009;16:261-269.

ILIAC INDICATION

ADVERSE EVENTS

The EverFlex™ self-expanding peripheral stent system (EverFlex stent) and the Protégé™ GPS self-expanding stent system (the stents) were evaluated in a study titled DURABILITY Iliac. A total of 75 subjects were enrolled; 31 of these subjects were implanted with the EverFlex™ stent. The primary objective was to confirm the safety and effectiveness of primary stenting using the stents for the treatment of stenotic, restenotic or occluded lesions in the common and external iliac arteries.

Table 16 provides a summary of the Clinical Events Committee (CEC) adjudicated Serious Adverse Events (SAEs) for all subjects implanted with the EverFlex stent in the DURABILITY Iliac study. They are summarized by MedDRA System/Organ Class and include all reported serious adverse events, regardless of study device, study procedure or study requirement relatedness. The data are presented as a percentage of subjects experiencing SAEs followed by the total number of events in brackets.

Table 16: Summary of Serious Adverse Events

MedDRA System Organ Class (MedDRA Preferred Term)	≤ 30 Days % (n/N) [Events]	≤ 9 Months % (n/N) [Events]	≤ 3 Years % (n/N) [Events]
Total*	16.1% (5/31) [6]	41.9% (13/31) [24]	54.8% (17/31) [46]
Cardiac disorders (Angina unstable, Cardiac failure congestive)	0.0% (0/31) [0]	9.7% (3/31) [5]	9.7% (3/31) [7]
Gastrointestinal disorders (Anal fistula)	0.0% (0/31) [0]	0.0% (0/31) [0]	3.2% (1/31) [1]
Infections and infestations (Pneumonia, Urinary tract infection)	3.2% (1/31) [1]	3.2% (1/31) [1]	6.5% (2/31) [2]
Injury, poisoning and procedural complications (Arterial injury, In-stent arterial restenosis)	0.0% (0/31) [0]	6.5% (2/31) [2]	12.9% (4/31) [5]
Neoplasms benign, malignant and unspecified (incl cysts and polyps) (Basal cell carcinoma, Lung neoplasm malignant, Non-Hodgkin's lymphoma recurrent, Pancreatic carcinoma, Skin cancer)	6.5% (2/31) [2]	9.7% (3/31) [3]	16.1% (5/31) [5]
Nervous system disorders (Carpal tunnel syndrome, Cerebrovascular accident, Transient ischaemic attack)	0.0% (0/31) [0]	6.5% (2/31) [2]	9.7% (3/31) [3]
Reproductive system and breast disorders (Breast mass)	0.0% (0/31) [0]	0.0% (0/31) [0]	3.2% (1/31) [1]
Respiratory, thoracic and mediastinal disorders** (Chronic obstructive pulmonary disease, Respiratory distress)	0.0% (0/31) [0]	0.0% (0/31) [0]	6.5% (2/31) [2]
Vascular disorders (Arterial stenosis, Artery dissection, Artery occlusion, Hypotension, Iliac artery stenosis, Peripheral artery dissection)	6.5% (2/31) [3]	16.1% (5/31) [11]	29.0% (9/31) [20]

*A total of 31/75 subjects were implanted with the EverFlex stent in the DURABILITY Iliac study.

**There was one (1) death that occurred in the study. The event that caused the death was categorized under "Respiratory, thoracic and mediastinal disorder". The event that caused the death was adjudicated by the CEC as not related to the device, procedure or study requirements.

POTENTIAL ADVERSE EVENTS

The potential adverse effects (e.g., complications) that may occur and/or require intervention with the use of this device include, but are not limited to:

- Abrupt or sub-acute closure
- Allergic reaction to device materials or procedure medications
- Allergic reaction to Nitinol
- Amputation
- Aneurysm
- Angina
- Arrhythmia
- Arterio-venous fistula
- Artery injury (e.g., dissection, perforation, or rupture)
- Bleeding requiring transfusion
- Bruising
- Contrast medium reaction/renal failure
- Death
- Device breakage
- Edema
- Embolism
- Failure to deploy stent
- Fever
- Gastrointestinal bleeding due to anticoagulation
- Hematoma
- Hypertension/Hypotension
- Infection
- Inflammation
- Intraluminal thrombus
- Myocardial infarction
- Pain
- Partial stent deployment
- Pseudoaneurysm
- Renal failure
- Renal insufficiency
- Restenosis
- Sepsis
- Shock
- Stent collapse or fracture
- Stent migration
- Stent misplacement
- Stroke
- Surgical or endovascular intervention
- Thrombosis/occlusion of the stent
- Transient ischemic attack
- Venous thromboembolism
- Vessel spasm
- Worsening claudication or rest pain

CLINICAL STUDIES

The DURABILITY Iliac study was a prospective, multi-center, non-randomized, single arm study to evaluate the EverFlex™ self-expanding stent system and the Protégé™ GPS self-expanding stent system (the stents) for the treatment of stenotic, restenotic (from PTA or adjunct therapy, not including stents or stent grafts) or occluded lesions of the common and/or external iliac arteries.

The objective of the study was to confirm the safety and effectiveness of the primary stenting.

A total of 75 subjects were enrolled at 13 US and two European investigational sites; 31 of the 75 subjects had an EverFlex stent implanted. Subject follow-up occurred at pre-discharge, 30 days, 9 months, 1, 2 and 3 years post-procedure. The primary outcome for the study was Major Adverse Event (MAE) rate at 9 months. Secondary outcomes were MAE rate at 30 days, primary patency rate at 9 months, change of ankle-brachial index at 30 days and 9 months, device success, change in walking impairment questionnaire score at 30 days and 9 months, and clinically driven target vessel revascularization at 30 days and 9 months.

SUBJECT ELIGIBILITY CRITERIA

Eligible subjects had claudication defined as Rutherford Clinical Category Score of 2 - 4. Target lesions were stenotic, restenotic (from PTA or adjunct therapy, not including stents or stent grafts) or occluded lesions. The reference vessel diameter of the target lesion was to be ≥ 4.5 and ≤ 11 mm and the lesion length ≤ 10 cm. To be included, they had to be at least 18 years old and consent to participate.

SUBJECT FOLLOW-UP

Table 17 summarizes subject follow-up compliance in the DURABILITY Iliac study. Percentages are based on the number of subjects implanted with an EverFlex stent that completed a visit.

Table 17: Summary of Subject Compliance

Time	Compliance*
Pre-discharge	100% (31/31)
30-Day	96.8% (30/31)
9-Month	90.3% (28/31)

*A total of 31/75 subjects were implanted with the EverFlex stent in the DURABILITY Iliac study.

Baseline demographics and clinical characteristics for subjects implanted with an EverFlex stent are presented in **Table 18**.

Table 18: Demographics and Baseline Clinical Characteristics

Subject Characteristics	N=31*
Age (yrs.), Mean± SD (N), [Median] (Min, Max)	62.6 ± 8.7 (31) [64.0] (49.0, 80.0)
Male	54.8% (17/31)
Race	
Caucasian	93.5% (29/31)
African American	3.2% (1/31)
Asian	0.0% (0/31)
American Indian or Alaska Native	0.0% (0/31)
Native Hawaiian or other Pacific Islander	3.2% (1/31)
Other	0.0% (0/31)
Ethnicity	
Hispanic	0.0% (0/31)
Not Hispanic	100.0% (31/31)
Risk Factors and Medical History	
Diabetes	16.1% (5/31)
Type I	0.0% (0/5)
Type II	100.0% (5/5)
Hyperlipidemia	58.1% (18/31)
Hypertension	74.2% (23/31)
Renal insufficiency	3.2% (1/31)
Current smoker	61.3% (19/31)
Angina	6.5% (2/31)
Arrhythmia	6.5% (2/31)
Congestive Heart Failure (CHF)	9.7% (3/31)
Stroke	9.7% (3/31)
Transient Ischemic Attack (TIA)	9.7% (3/31)
Myocardial Infarction (MI)	6.5% (2/31)
No-healing ischemic ulcers in the lower extremities	0.0% (0/31)
Amputation of the lower extremities	0.0% (0/31)
Peripheral Intervention**	19.4% (6/31)
Clinical Characteristics	
Rutherford Clinical Category	
2=Moderate claudication	45.2% (14/31)
3=Severe claudication	51.6% (16/31)
4=Ischemic rest pain	3.2% (1/31)
Ankle-Brachial Index (ABI)	0.68 ± 0.15 (30) [0.69] (0.29, 0.95)

*A total of 31/75 subjects were implanted with the EverFlex stent in the DURABILITY Iliac study.

**Types of historical peripheral interventions included: PTA, Stenting, Atherectomy, or Bypass. There was no history of Cryoplasty, Laser or other types of interventions.

ILIAC INDICATION (continued)

Table 19 presents baseline characteristics assessed by the angiographic core laboratory for the subjects with the EverFlex™ stent.

Table 19: Baseline Target Lesion Characteristics

Lesion Characteristics	N=32 (# of lesions)*
Right Iliac Artery	56.3% (18/32)
Common	44.4% (8/18)
External	55.6% (10/18)
Left Iliac Artery	43.8% (14/32)
Common	71.4% (10/14)
External	28.6% (4/14)
Lesion Morphology	
Distance from Ostium (mm)	38.6 ± 38.4 (32) [32.0] (0.0, 129.4)
Lesion Length (mm)	42.8 ± 25.8 (32) [37.7] (7.0, 114.9)
Eccentric Lesion	53.1% (17/32)
Bend	11.3 ± 7.0 (32) [10.0] (0.0, 30.0)
Thrombus	0.0% (0/32)
Any Calcification	56.3% (18/32)
None/Mild	43.8% (14/32)
Moderate	31.3% (10/32)
Severe	25.0% (8/32)
Ulceration present	25.0% (8/32)
Aneurysm present	9.4% (3/32)
TASC II	
Type A	46.9% (15/32)
Type B	40.6% (13/32)
Type C	6.3% (2/32)
Type D	6.3% (2/32)
Quantitative Angiographic Results	
Pre-procedure Reference Diameter (mm)	6.7 ± 1.2 (32) [6.8] (4.4, 9.6)
Pre-procedure Minimal Lumen Diameter (mm)	1.9 ± 1.2 (32) [2.2] (0.0, 4.2)
Pre-procedure % Diameter Stenosis	71.4 ± 16.9 (32) [69.5] (45.1, 100.0)
Percent Total Occlusions (100% stenosis)	18.8% (6/32)
*A total of 31 subjects with 32 target lesions were implanted with the EverFlex stent. One subject had two target lesions, one treated with the Protégé GPS stent and one treated with the EverFlex stent.	

CLINICAL RESULTS

PRIMARY OUTCOME

The primary outcome of the study is MAE rate at 9 months (270 days) post-procedure. An MAE was defined as a composite of periprocedural death, in hospital MI, clinically-driven target lesion revascularization, and amputation of treated limb, as adjudicated by the Clinical Event Committee (CEC). The 9-month MAE rate for subjects implanted with the EverFlex stent was 0.0% (0/31) (**Table 20**).

Table 20: Summary of Primary Outcome

9-Month MAE	N=31* % (n/N) [Events]
9-Month MAE	0.0% (0/31) [0]
Periprocedural Death	0.0% (0/31) [0]
In-hospital MI	0.0% (0/31) [0]
Clinically-driven TLR	0.0% (0/31) [0]
Amputation of the Treated limb	0.0% (0/31) [0]
*A total of 31/75 subjects were implanted with the EverFlex stent in the DURABILITY Iliac study.	

Figure 4 displays the freedom from Major Adverse Event at 9 months.

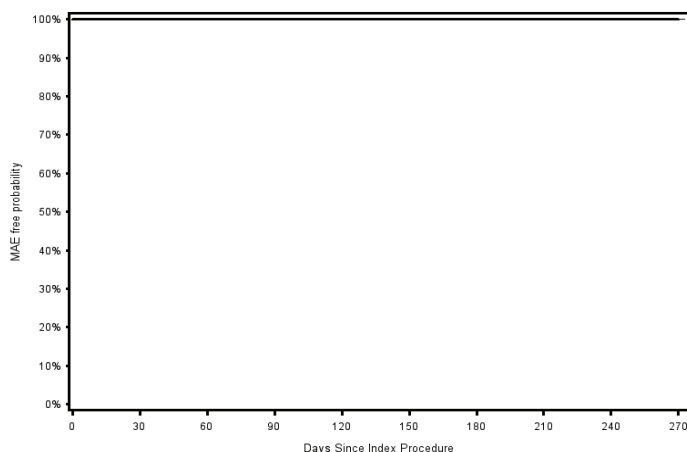

Figure 4: Freedom from MAE at 9 Months (270 days), All Subjects (N=31)

OUTCOME SUMMARY

Table 21 provides a summary of the primary and secondary outcome measures for the 31 subjects implanted with the EverFlex stent in the DURABILITY Iliac study.

Table 21: Summary of Primary and Secondary Outcomes

Primary Outcome Measures	N=31*
9-Month MAE ¹	0.0% (0/31) [0]
Periprocedural Death	0.0% (0/31) [0]
In-hospital MI	0.0% (0/31) [0]
Clinically-driven TLR	0.0% (0/31) [0]
Amputation of the Treated limb	0.0% (0/31) [0]
Freedom from 9-Month MAE -KM Estimate	100.0%
Secondary Outcome Measures	N=31*
30-Day MAE ¹	0.0% (0/31) [0]
Periprocedural Death	0.0% (0/31) [0]
In-hospital MI	0.0% (0/31) [0]
Clinically driven TLR	0.0% (0/31) [0]
Amputation of the Treated limb	0.0% (0/31) [0]
Primary Patency Rate at 9 Months - KM Estimate ²	93.2%
Device Success ³	100.0% (32/32)**
Freedom from clinically-driven TVR at 30 days -KM Estimate	100.0%
Freedom from clinically-driven TVR at 9 months KM Estimate	100.0%
*A total of 31/75 subjects were implanted with the EverFlex stent in the DURABILITY Iliac study. **A total of 31 subjects with 32 target lesions were implanted with the EverFlex stent. One subject had two target lesions, one treated with the Protégé GPS stent and one treated with the EverFlex stent.	
¹ Numbers are % (n/N) [Events]	
² Primary patency rate defined as a binary duplex ultrasound ratio ≤ 2.4 at the stented target lesion with no clinically-driven re-intervention within the stented segment	
³ Device success was defined as the ability to deploy the stent as intended at the treatment site. The denominator includes number of stents implanted.	

CONCLUSION

Overall, the data supports the conclusion that the clinical benefits of primary stenting with the EverFlex stent, outweigh the risks in the intended population. The results of the study provide reasonable assurance that the EverFlex stent is safe and effective for the treatment of stenotic, restenotic or occluded lesions in the common and external iliac arteries.

PROCEDURE for SFA and ILIAC INDICATIONS

PROCEDURE

PREPARATION PROCEDURES

WARNING: The device is provided STERILE for single use only. Do not reprocess or sterilize. Reprocessing and resterilizing could increase the risk of patient infection and risk of compromised device performance.

1. Required Items for Implantation Procedure

- 5-10 cc syringe filled with heparinized saline
- 0.035" Exchange guidewire
- Hemostatic sheath
- PTA Balloon

2. Select Stent Size

Refer to **Table 1** and **Table 2** for stent sizing information.

Measure the diameter of the reference vessel (proximal and distal to lesion). Measure the length of the target lesion. Choose a stent length that will extend proximal and distal to the target lesion.

3. Preparation of Stent Delivery System

- Open the shelf box to reveal the pouch containing the stent and delivery catheter.
- After careful inspection of the pouch, looking for damage to the sterile barrier, carefully peel open the outer pouch and extract the tray with contents.
- Set the tray on a flat surface. Carefully pull the lid off the tray and remove the stent/delivery system.
CAUTION: Carefully inspect the sterile package and device prior to use to verify that no damage occurred during shipment.
- Verify the device is locked by tightening the safety lock clockwise.
CAUTION: Do not exceed 300 psi / 20 ATM while flushing the delivery system.
- Attach a 5-10 cc syringe filled with heparinized saline to the stopcock on the manifold. Open the stopcock and vigorously inject saline into the annular space between the shafts until it comes out the outer sheath.
- Attach a 5-10 cc syringe filled with heparinized saline to the proximal luer lock injection hub. Inject the saline solution through the guidewire lumen until it comes out the catheter tip.
- Examine the distal end of the catheter to ensure the stent is flush with the outer subassembly. If a gap exists between the catheter tip and outer subassembly, open the safety lock and gently pull the inner shaft in a proximal direction until the gap is closed. Lock the safety lock after the adjustment by turning the knob clockwise.
CAUTION: Do not use if the stent is partially deployed upon removal from the package, or before starting the deployment procedure.

STENT DEPLOYMENT PROCEDURE

1. Insertion of Sheath and Guidewire

- Gain femoral access using a sheath with a hemostatic valve that is compatible with a 6 F delivery system. The sheath should be of adequate length to provide support of stent delivery system.
NOTE: For SFA procedure, the sheath should be of adequate length to provide support of stent delivery system beyond the aortoiliac arch.
CAUTION: Support from a sheath is necessary to minimize lengthening or shortening during stent deployment.
- Insert a guidewire of appropriate length across the target lesion via the sheath.
CAUTION: Always use a sheath during the implant procedure to protect both the vessel and puncture site.

2. Dilatation of Lesion

Pre-dilate the lesion using standard PTA techniques. Remove the PTA balloon from the patient while maintaining lesion access with the guidewire.

CAUTION: Failure to pre-dilate the lesion may impair the ability to remove the stent system after stent deployment.

3. Introduction of Stent Delivery System

Advance the device over the guidewire through the hemostatic valve and sheath.

WARNING: If resistance is encountered at any time during the insertion procedure, do not force passage. Resistance may cause damage to stent or vessel. Carefully withdraw the stent system without deploying the stent.

4. Stent Deployment

- Advance the delivery system until the distal (leading) radiopaque inner subassembly marker is distal to the target lesion.
NOTE: For the 200 mm stent delivery system, the stent will move back approximately 5 mm from the distal retainer upon initial release.
- Pull back on the delivery system until there is no slack in the delivery system and the radiopaque inner subassembly markers extend distal and proximal to the target lesion.
- Open the safety lock by turning the knob counterclockwise.
- Initiate stent deployment by pinning down (holding) the inner subassembly (proximal grip) in a fixed position and pulling the outer subassembly (distal grip) toward the proximal grip as shown in **Figure 5**.

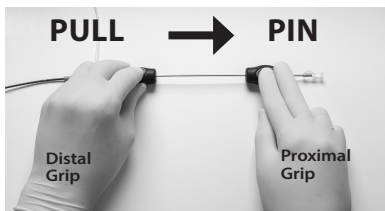

Figure 5: Stent Deployment

- Once initial deployment is visible on fluoroscopy and prior to achieving vessel apposition, reposition stent as needed using radiopaque markers.
NOTE: It is recommended to lock the safety lock in order to ensure that there is no relative movement between the grips during repositioning.
CAUTION: The stent system is not designed for recapturing or repositioning after establishing vessel apposition.
- During deployment of the stent, the whole length of the flexible deployment system should be kept as straight as possible. In order to ensure that no slack is introduced into the delivery system, hold the proximal grip stationary and fixed. Deployment is complete when the outer subassembly marker passes the proximal inner shaft stent marker and the stent is released.

WARNING: If resistance is felt when initially pulling back on the distal grip, do not force deployment. Carefully withdraw the stent system without deploying the stent.

CAUTION: Failure to hold the proximal grip in a fixed position may result in partial deployment, foreshortening, lengthening or increased deployment force.

CAUTION: The stent is not designed to be lengthened or shortened past its nominal length. Excessive stent lengthening or shortening may increase the risk of stent fracture.

NOTE: If a second stent is needed, place the more distal stent first. If overlap of sequential stents is necessary, the amount of overlap should be kept to a minimum.

5. Post Stent Deployment

- While using fluoroscopy following stent deployment, withdraw the entire delivery system as one unit, over the guidewire, into the catheter sheath and out of the body. Remove the delivery system from the guidewire.

WARNING: If resistance is met during delivery system withdrawal, advance the outer subassembly until the outer subassembly marker contacts the catheter tip and withdraw the system as one unit.

- Using fluoroscopy, visualize the stent to verify full deployment.
- If incomplete expansion exists within the stent at any point along the lesion, post deployment balloon dilation may be performed.

CAUTION: Use caution when crossing a deployed stent with any adjunct device.

CAUTION: Stent should not be expanded past its nominal diameter.

- To dilate the stent, select an appropriate size PTA balloon catheter and dilate with conventional technique. The inflation diameter of the PTA balloon should approximate the diameter of the reference vessel.
- Confirm full stent expansion is complete, then remove the PTA balloon from the patient.
- Remove the guidewire and sheath from the body.
- Close entry wound as appropriate.
- Discard the delivery system, guidewire and sheath.

Protégé™ EverFlex™

Self-expanding Biliary Stent System

INSTRUCTIONS FOR USE

BILIARY INDICATION

DEVICE DESCRIPTION

The Protégé™ EverFlex™ self-expanding biliary stent system is a self-expanding Nitinol stent system designed for the palliative treatment of malignant neoplasms in the biliary tree. The self-expanding stent is made of a nickel titanium alloy (Nitinol) and comes pre-mounted on a 6 F 0.035" over-the-wire delivery system. The stent is cut from a Nitinol tube into an open lattice design and has tantalum radiopaque markers at the proximal and distal ends of the stent. Upon deployment, the stent achieves its predetermined diameter and exerts a constant, gentle outward force to establish patency in the biliary ducts.

The delivery system, as shown in **Figure 6**, is comprised of an inner shaft (1) and outer (2) sheath, which are locked together with a safety lock (3). The nylon inner shaft terminates distally in a flexible catheter tip (4) and originates proximally at the hub (5). Two radiopaque markers, one marker distal (6) and one marker/retainer proximal (7) to the constrained stent, are on the inner shaft.

The outer sheath connects proximally to the Y-adaptor (8). The self-expanding stent is constrained within the space between the inner shaft and outer sheath. This space is flushed prior to the procedure through the stopcock (9). The outer sheath has a radiopaque marker at its distal end (10).

Stent positioning at the target stricture is achieved prior to deployment by utilizing the two radiopaque markers on the inner shaft, and the radiopaque markers on the stent. For stent deployment, the safety lock is turned counterclockwise to unlock the outer sheath.

The outer sheath retraction is achieved by pulling the distal grip (11) toward the proximal grip (12). Complete deployment of the stent is achieved when the radiopaque marker on the outer sheath passes the proximal radiopaque marker on the inner shaft.

Refer to **Table 1** and **Table 2** for stent sizing information.

INDICATIONS FOR USE

The stent is intended as a palliative treatment of malignant neoplasms in the biliary tree.

CONTRAINDICATIONS

None known.

WARNINGS

- The safety and effectiveness of this device for use in the vascular system have not been established.
- The device is provided STERILE for single use only and should be used by the "Use By" date printed on the package. Do Not Resterilize.
- If resistance is encountered at any time during the insertion procedure, do not force passage. Resistance may cause damage to stent or lumen. Carefully withdraw the stent system without deploying the stent.
- If resistance is felt when pulling back on the distal grip, do not force deployment. Carefully withdraw the stent system without deploying the stent.
- If resistance is met during delivery system withdrawal, advance the outer sheath until the outer sheath marker contacts the catheter tip and withdraw the system as one unit.

PRECAUTIONS

- Carefully inspect the sterile package and device prior to use to verify that no damage occurred during shipment.
- Do not exceed 300 psi / 20 ATM while flushing the delivery system.
- Do not use if the stent is partially deployed.
- Support from a sheath is necessary to minimize lengthening or shortening during stent deployment.
- Always use a sheath during the implant procedure to protect both the liver tract and puncture site.
- The stent is not designed for either repositioning after establishing duct apposition or recapturing.
- Failure to hold the proximal grip in a fixed position may result in partial deployment, foreshortening, lengthening or increased deployment force.
- The stent is not designed to be stretched past its nominal length.
- The effects of overlapping stents have not been evaluated.
- Use caution when crossing a deployed stent with any adjunct device.
- Stent should not be expanded past its nominal diameter.
- Federal (U.S.A.) law restricts this device to sale by or on the order of a physician

POTENTIAL ADVERSE EVENTS

Potential hazards and side effects include, but are not limited to:

- Infection secondary to contamination of the stent may lead to cholangitis, hemobilia, peritonitis, or abscess.
- The stent may migrate from the site of implant down the biliary tract.
- Overstretching the duct may result in rupture.
- Persons with allergic reactions to nickel titanium (nitinol) may suffer an allergic response to this implant.
- Device breakage.
- Failure to deploy stent.
- Partial stent deployment.
- Stent collapse or fracture.
- Stent misplacement.
- Surgical intervention.

PROCEDURE

PREPARATION PROCEDURES

Required items:

- 5-10 cc syringe filled with saline
- 0.035" guidewire
- Sheath

1. Inject Contrast Medium

Perform a percutaneous cholangiogram using standard technique.

2. Evaluate and Mark Stricture

Fluoroscopically evaluate and mark the stricture, observing the most distal level of the biliary stricture.

3. Select Stent Size

Measure the diameter of the reference bile duct (proximal and distal to the stricture). Refer to **Table 1** for stent diameter sizing. Measure the length of the target stricture. Choose a stent length that will extend proximal and distal to the tumor to protect against impingement from further tumor growth.

4. Preparation of Stent Delivery System

- Open the outer box to reveal the pouch containing the stent and delivery catheter.
- After careful inspection of the pouch, looking for damage to the sterile barrier, carefully peel open the outer pouch and extract the tray with contents.
- Set the tray on a flat surface. Carefully pull the lid off the tray and remove the stent/delivery system. If it is suspected that the sterility has been compromised or the device is damaged do not use the device.
CAUTION: Carefully inspect the sterile package and device prior to use to verify that neither has been damaged during shipment.

- Verify the device is locked by tightening the safety knob clockwise.

CAUTION: Do not exceed 300 psi / 20 ATM while flushing.

- Attach a 5-10 cc syringe filled with saline to the stopcock on the manifold. Open the stopcock and vigorously inject saline into the annular space between the shafts until it comes out the outer sheath.
- Attach a 5-10 cc syringe filled with saline to the proximal luer lock injection hub. Inject the saline solution through the guidewire lumen until it comes out the catheter tip.
- Examine the distal end of the catheter to ensure the stent is contained within the outer sheath. Do not use if the stent is partially deployed. If a gap exists between the catheter tip and outer sheath, open the safety knob and gently pull the inner shaft in a proximal direction until the gap is closed. Lock the safety knob after the adjustment by turning the knob clockwise.

CAUTION: Do not use if the stent is partially deployed.

STENT DEPLOYMENT PROCEDURE

1. Insertion of Sheath and Guidewire

- Gain access at the appropriate site utilizing a sheath that is compatible with a 6 F delivery system.

CAUTION: Support from a sheath is necessary to minimize lengthening or shortening during stent deployment.

- Insert 0.035" guidewire of appropriate length across the target stricture via the sheath.

CAUTION: Always use a sheath during the implant procedure to protect both the liver tract and puncture site.

2. Dilation of Stricture

Generally, predilation is not performed on malignant strictures. However, if it is determined that predilation is necessary, use standard balloon dilation techniques. Remove the balloon catheter from the patient while maintaining stricture access with the guidewire.

3. Introduction of Stent Delivery System

Advance the device over the guidewire and through the sheath.

WARNING: If resistance is encountered at any time during the insertion procedure, do not force passage. Resistance may cause damage to stent or duct. Carefully withdraw the stent system without deploying the stent.

4. Stent Deployment

- Advance the delivery system until the distal (leading) radiopaque inner shaft marker is distal to the target stricture.
- Pull back on the delivery system until there is no slack in the delivery system and the radiopaque inner shaft markers extend distal and proximal to the target stricture.
- Open the safety lock by turning the knob counterclockwise.
- Initiate stent deployment by pinning down (holding) the inner shaft (proximal grip) in a fixed position and pulling the outer sheath (distal grip) toward the proximal grip as shown in **Figure 6**.
- Once initial deployment is visible and prior to achieving duct apposition, reposition stent as needed using radiopaque markers.

NOTE: It is recommended to lock the safety lock in order to ensure that there is no relative movement between the grips during repositioning.

CAUTION: The stent is not designed for either repositioning after establishing duct apposition or recapturing.

- During release of the stent, the whole length of the flexible deployment system should be kept as straight as possible. In order to ensure that no slack is introduced in to the delivery system, hold the proximal grip stationary and fixed. Deployment is complete when the outer sheath marker passes the proximal inner shaft stent marker and the stent is released.

WARNING: If resistance is felt when initially pulling back on the distal grip, do not force deployment. Carefully withdraw the stent system without deploying the stent.

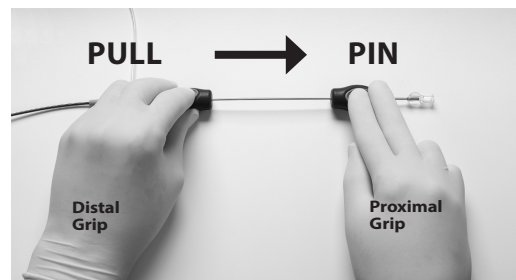

Figure 6: Stent Deployment

CAUTION: Failure to hold the proximal grip in a fixed position could lead to partial deployment, foreshortening, lengthening or increased deployment force.

CAUTION: The stent is not designed to be stretched past its nominal length.

NOTE: If a second stent is needed, place the more distal stent first. If overlap of sequential stents is necessary, the amount of overlap should be kept to a minimum.

CAUTION: The effects of overlapping stents have not been evaluated.

5. Post Stent Deployment

- While using fluoroscopy, withdraw the entire delivery system as one unit, over the guidewire, into the catheter sheath and out of the body. Remove the delivery system from the guidewire.

WARNING: If resistance is met during delivery system withdrawal, advance the outer sheath until the outer sheath marker contacts the catheter tip and withdraw the system as one unit.

- Using fluoroscopy, visualize the stent to verify full deployment.
- If incomplete expansion exists within the stent at any point along the stricture, post deployment balloon dilation can be performed.

BILIARY INDICATION (continued)

CAUTION: Use caution when crossing a deployed stent with any adjunct device.

CAUTION: Stent should not be expanded past its nominal diameter.

Select an appropriate size balloon catheter that is labeled for biliary stent deployment and/or optimization, and dilate the stricture with conventional technique. The inflation diameter of the balloon used for post dilation should approximate the diameter of the reference biliary duct. Remove the balloon from the patient.

- d. Remove the guidewire and sheath from the body.
- e. Close entry wound as appropriate.
- f. Discard the delivery system, guidewire and sheath.

NOTE: Physician experience and discretion will determine the appropriate drug regimen for each patient.

MRI INFORMATION (for all indications)

MRI INFORMATION



Non-clinical testing demonstrated that the EverFlex stent is MR Conditional for lengths up to 200 mm. A patient may be scanned safely, immediately after stent placement under the following conditions:

- Static magnetic field of 3-Tesla or 1.5-Tesla
- Maximum spatial gradient magnetic field of 8,000-Gauss/cm (extrapolated) or less (80 T/m)
- The maximum whole-body averaged specific absorption rate (SAR) shall be limited to 2.0 W/kg (normal operating mode) for 15 minutes of scanning (per pulse sequence)

MRI-RELATED HEATING

Under the scan conditions defined above, the EverFlex stent is expected to produce a maximum temperature rise of 4.5° C after 15 minutes of continuous scanning (per pulse sequence).

These temperature changes will not pose a hazard to a patient under the conditions indicated above. It is recommended that patients register conditions under which the implant may be scanned safely with the MedicAlert Foundation (www.medicalert.org) or equivalent organization.















ARTIFACT INFORMATION

The maximum artifact size as seen on the gradient echo pulse sequence at 3-Tesla extends approximately 5 mm relative to the size and shape of the EverFlex stent. The lumen of the stent cannot be visualized using the T1-weighted, spin echo and gradient echo pulse sequences at 3-Tesla.

WARRANTY DISCLAIMER

Although this product has been manufactured under carefully controlled conditions, ev3 Inc. has no control over the conditions under which this product is used. ev3 Inc. therefore disclaims all warranties, both express and implied, with respect to the product including, but not limited to, any implied warranty of merchantability or fitness for a particular purpose. ev3 Inc. shall not be liable to any person or entity for any medical expenses or any direct, incidental or consequential damages caused by any use, defect, failure or malfunction of the product, whether a claim for such damages is based upon warranty, contract, tort or otherwise. No person has any authority to bind ev3 Inc. to any representation or warranty with respect to the product. The exclusions and limitations set out above are not intended to, and should not be construed so as to contravene mandatory provisions of applicable law. If any part or term of this Disclaimer of Warranty is held to be illegal, unenforceable or in conflict with applicable law by a court of competent jurisdiction, the validity of the remaining portions of this Disclaimer of Warranty shall not be affected, and all rights and obligations shall be construed and enforced as if this Disclaimer of Warranty did not contain the particular part or term held to be invalid.

SYMBOL LEGEND

	MR conditional
	Manufacturer
	Consult instructions for use
	Sterilized using ethylene oxide
	Catalogue number
	Batch code
	Keep dry
	Keep away from sunlight
	Use-by date
	Do not re-use
	Do not use if package is damaged
	Telephone
	Facsimile
	For prescription use only

CONTACT INFORMATION

If you have any questions or comments regarding the use of this product contact:



Manufacturer

ev3 Inc.
4600 Nathan Lane North
Plymouth, MN 55442 USA
PH +1 763 398 7000
FX +1 763 398 7001
Tollfree +1 800 716 6700
www.ev3.net

©2014 Covidien. All rights reserved.
EverFlex and Protégé are trademarks of a Covidien company.