



DIAMONDBACK 360[®] Coronary Orbital Atherectomy System

Including the DIAMONDBACK 360[®] Coronary Orbital Atherectomy Device, Saline Infusion Pump, and VIPERWIRE Advance[®] Coronary Guide Wire

Instructions for use

Caution: Federal Law (USA) restricts this device to sale by or on the order of a physician.

The following are trademarks of Cardiovascular Systems, Inc.:

CSI[®], Cardiovascular Systems[®], DIAMONDBACK 360[®], VIPERSLIDE[®], VIPERWIRE
Advance[®]

Explanation of symbols on package labels

Refer to the package labels to see which symbols apply to specific products.



Model number



Caution - consult www.csi360.com for Instructions for use



Lot number



Do not reuse



Manufacturer



Maximum tip diameter



Maximum shaft diameter



Guide wire length



Use by



Crown diameter



Guide wire



Crown style



Nose length



Shaft length

Explanation of symbols on the Saline Infusion Pump



Low saline red LED indicator



Start button and green LED pump on indicator



Pump status yellow LED indicator



Prime button

Table of contents

1	System description.....	1
2	Indications for use.....	6
3	Contraindications.....	6
4	Warnings.....	6
5	Precautions.....	8
6	OAS component storage and handling.....	9
7	Adverse events.....	10
8	Clinical study summary.....	11
9	Equipment, set up, and test.....	21
10	OAS directions for use.....	28
11	Specifications.....	35
12	OAS Pump declaration of conformity.....	37
13	EMC declaration.....	37
	Appendix A – OAS Troubleshooting.....	38
	Appendix B – Maximum orbit and resulting lumen diameter.....	44
	Appendix C – Orbit performance.....	45

1. System description

The Cardiovascular Systems, Inc. (CSI) DIAMONDBACK 360 Coronary Orbital Atherectomy System (OAS) is a catheter-based system designed for facilitating stent delivery in patients with coronary artery lesions. The OAS consists of the hand-held CSI DIAMONDBACK 360 Coronary Orbital Atherectomy Device (OAD), the CSI Saline Infusion Pump (OAS pump), the CSI VIPERWIRE Advance Coronary Guide Wire (VIPERWIRE guide wire), and the CSI VIPERSLIDE Lubricant. The OAS reduces coronary plaque on the vessel wall by using a rotating, diamond-coated crown, within coronary arteries, in order to facilitate stent delivery.

The OAS consists of the following:

- DIAMONDBACK 360 Coronary Orbital Atherectomy Device Model DBEC-125 or DBEC-150
- Orbital Atherectomy System Pump Model SIP-3000
- VIPERWIRE Advance Coronary Guide Wire Model GWC-12325LG-FLP
- VIPERSLIDE Lubricant Model VPR-SLD2

Caution: The OAD and VIPERWIRE Guide Wire are for use with DIAMONDBACK 360 coronary OAS components only.

1.1 Orbital Atherectomy Device (OAD)

The orbital atherectomy device (OAD) is a hand-held, over-the-wire device that includes a sheath-covered drive shaft and a diamond-coated crown (Figure 1). The diamond coating on the crown provides an abrasive surface with which to reduce coronary plaque within coronary arteries. The OAD is designed to track and rotate only over the CSI VIPERWIRE Advance Coronary Guide Wire. **Do not use any other guide wire with the OAD.** Select a crown size according to the crown's ability to cross the coronary artery lesion and based upon the maximum lumen potential of the crown. See Table 1 for available crown sizes. See Appendices B and C for orbit performance.

Figure 1. OAD

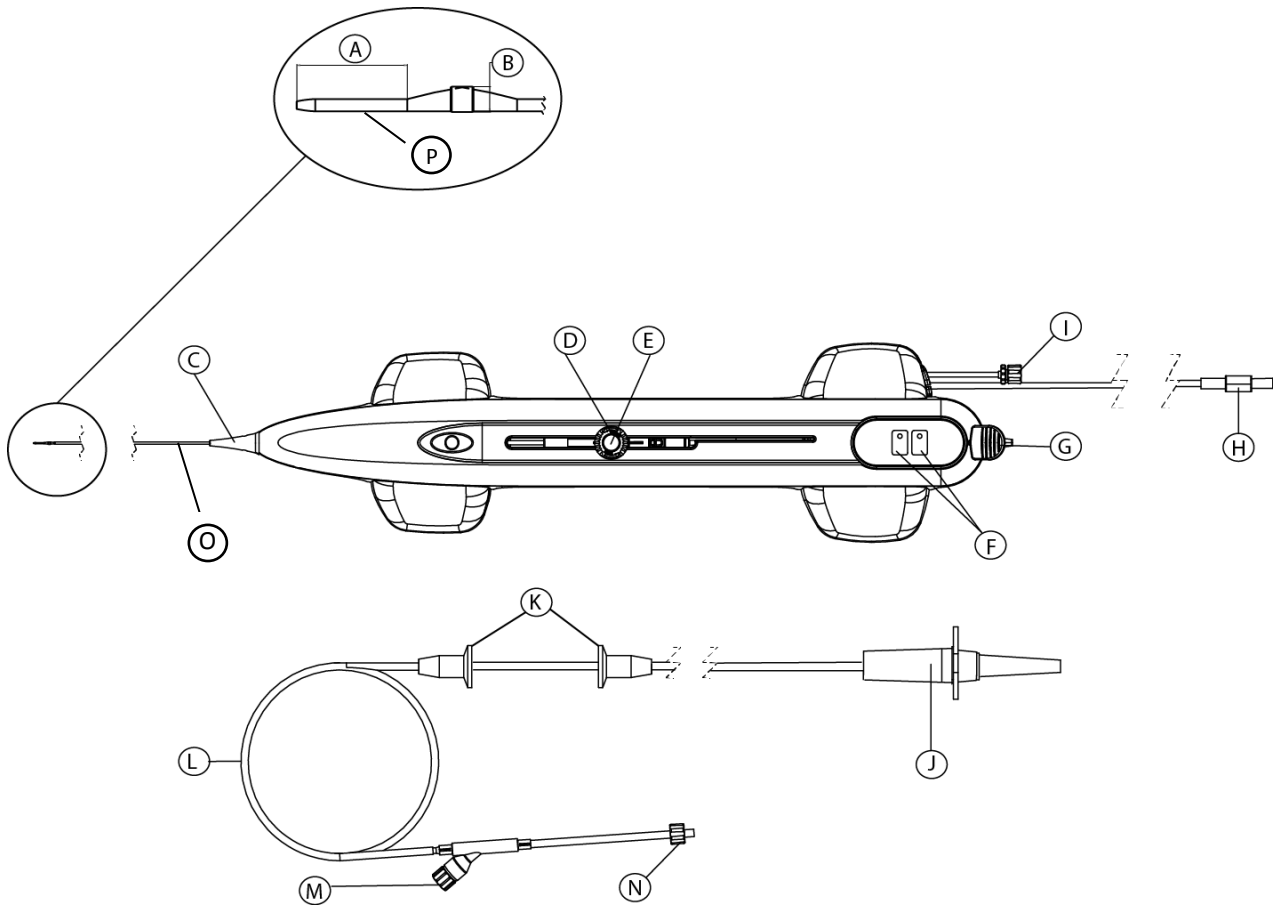

- A. Nose length
- B. Crown diameter
- C. Strain relief
- D. Lockable crown advancer knob
- E. On/Off button
- F. Crown rotation speed buttons and indicators
- G. Guide wire brake lever
- H. Electrical power cord
- I. OAD saline infusion port connector
- J. Saline bag spike
- K. Saline tubing positioners
- L. Saline tubing
- M. Injection port
- N. Saline line infusion port connector
- O. Sheath
- P. Drive Shaft

Table 1. Crown sizes

Model Number	Crown Size (mm)	Nose Length* (mm)	Maximum Lumen (mm)	OAD maximum catheter outer diameter (mm)	Minimum guide catheter diameter
DBEC-125	1.25	5	1.84	1.34	6 French with an internal diameter of at least 0.066 inches (1.68 mm)
DBEC-150**	1.50	10	2.16	1.34	

* Nose length is the length of the drive shaft from the crown to the distal tip of the shaft.

** The DBEC-150 crown size should only be used for crossing lesions of a diameter greater than 1.25mm.

OAD components:

- crown
- crown advancer knob
- drive shaft
- sheath (covering the drive shaft up to the crown)
- electrical power cord
- saline tubing for connecting the OAS pump to the OAD

OAD features:

- On/Off button that allows the user to control when crown rotation starts and stops
- 2 speed control buttons that allow the user to select the crown rotation speed
- crown advancement measurement indicators
- manual guide wire brake that allows the user to restrict both the rotational and axial movement of the VIPERWIRE guide wire
- an eccentrically-mounted, diamond-coated crown that provides an abrasive surface with which to reduce coronary plaque on the vessel wall
- a green polymer strain relief on the nose of the OAD that prevents kinks where the sheath and the drive shaft attach to the handle

1.2 OAD package contents

The OAD and accessories are supplied sterile and are for single-use only. Each package contains:

- OAD Model DBEC-125 or DBEC-150
- Saline tubing (connects the OAD to the OAS pump)

1.3 OAS Pump

The OAS pump provides the saline pumping mechanism and power to the OAD. The small, reusable, and portable OAS pump attaches to a standard five-wheel rolling intravenous (IV) pole (Figure 2). The OAS pump includes a built-in, audible 25 second spin time notification, OAS power and priming buttons, and status indicators.

Figure 2. OAS Pump

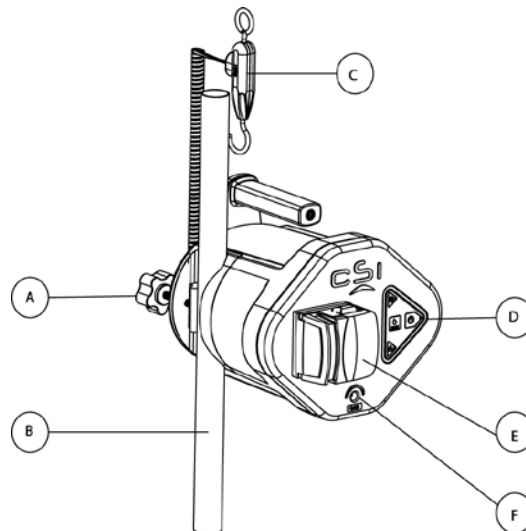

- A. IV pole screw clamp
- B. IV pole (not included)
- C. Low saline level sensor and connector cord
- D. Control panel
- E. OAS pump door
- F. OAD connection

1.4 OAS Pump package contents

The OAS pump and accessories are supplied non-sterile. Each package contains:

- OAS pump Model SIP-3000 with attached IV pole screw clamp
- Power cord
- Low saline level sensor and connector cord

1.5 VIPERWIRE Advance Coronary Guide Wire

The VIPERWIRE guide wire is a smooth, stainless steel wire, with a silicone coating, and a radiopaque distal spring tip (Figure 3). The VIPERWIRE guide wire allows for proper positioning of the OAD crown within coronary arteries and provides a center of rotation for the OAD drive shaft. The VIPERWIRE guide wire torquer is an accessory, packaged with the VIPERWIRE guide wire, and provides a gripping surface for manipulating the VIPERWIRE guide wire.

Figure 3. VIPERWIRE Guide Wire

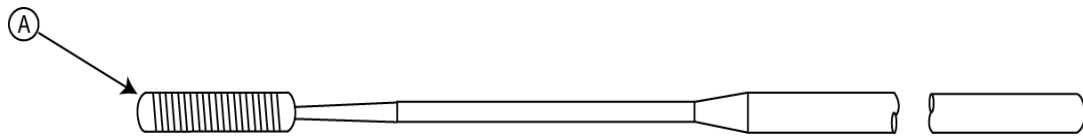

A. Distal spring tip

1.6 VIPERWIRE Advance Coronary Guide Wire package contents

The VIPERWIRE guide wire and VIPERWIRE guide wire torquer are supplied sterile and are for single-use only. Each package contains:

- Five (5) VIPERWIRE guide wires Model GWC-12325LG-FLP (sterile)
- Five (5) VIPERWIRE guide wire torquers (sterile)

1.7 VIPERSLIDE Lubricant

VIPERSLIDE Lubricant reduces friction between the OAD drive shaft and the VIPERWIRE guide wire.

Note: Please refer to the VIPERSLIDE Lubricant IFU prior to starting the atherectomy procedure.

2. Indications for use

The DIAMONDBACK 360 Coronary Orbital Atherectomy System (OAS) is a percutaneous orbital atherectomy system indicated to facilitate stent delivery in patients with coronary artery disease (CAD) who are acceptable candidates for PTCA or stenting due to *de novo*, severely calcified coronary artery lesions.

3. Contraindications

Use of the OAS is contraindicated in the following situations:

- The VIPERWIRE guide wire cannot pass across the coronary lesion.
- The target lesion is within a bypass graft or stent.
- The patient is not an appropriate candidate for bypass surgery, angioplasty, or atherectomy therapy.
- The patient has angiographic evidence of thrombus.
- The patient has only one open vessel.
- The patient has angiographic evidence of significant dissection at the treatment site.
- Women who are pregnant or children.

4. Warnings

- Do **not** use the OAS if the physician does not have experience in coronary angioplasty at their institution.
- Do **not** use the OAS if the physician does not have training on using the OAS.
- Do **not** use other commercially-available guide wires with the OAD. Only use the Model GWC-12325LG-FLP VIPERWIRE Advance Coronary Guide Wire with the coronary OAD. The VIPERWIRE guide wire is designed for use with all coronary OAD crown and shaft configurations.
- **Never** operate the OAD without normal saline and VIPERSLIDE lubricant. Continually flowing saline and VIPERSLIDE lubricant is required for cooling and lubricating the OAD during use in order to avoid overheating and permanent damage to the device and possible injury to the patient.
- Do **not** use the OAD or the VIPERWIRE guide wire if their sterile package barriers are compromised or damaged.
- Do **not** re-sterilize or re-use the OAD. If the OAD is re-sterilized or re-used, the OAD may not function properly potentially leading to serious infection and patient harm and/or death.

- Do **not** re-sterilize or re-use the VIPERWIRE guide wire or the guide wire torquer. If the VIPERWIRE guide wire or torquer is re-sterilized or re-used, the guide wire may not function properly potentially leading to serious infection and patient harm and/or death.
- Never force the crown if any resistance is felt within the vessel as vessel perforation may occur. If resistance is felt, retract the crown, while monitoring the cause of the resistance, and immediately stop treatment. Use fluoroscopy to analyze the situation and to monitor the cause of the resistance.
- Do **not** come within 5 mm of the proximal end of the VIPERWIRE guide wire spring tip with the distal end of the OAD drive shaft. If the distance between the shaft tip and the VIPERWIRE guide wire spring tip is insufficient, the shaft tip may contact the guide wire spring tip and result in dislodging the guide wire spring tip. Use fluoroscopy to monitor movement of the shaft tip in relation to the VIPERWIRE guide wire spring tip.
- Immediately stop using any OAS component should mechanical failure of any component occur before or during the atherectomy procedure. Using damaged components may result in OAS malfunction or patient injury.
- Initial treatment for each lesion must start at low speed.
- Do **not** operate the OAD if there is a bend, kink, or tight loop in the VIPERWIRE guide wire. A bend, kink, or tight loop in the VIPERWIRE guide wire may cause damage to and malfunctioning of the device during use.
- Performing treatment in excessively tortuous vessels or bifurcations may result in vessel damage.
- Always keep the crown advancing or retracting, while it is rotating, by continually moving the control knob to ensure 1:1 movement between the control knob and the rotating crown.
- Once the OAD has reached full speed (as indicated by a stable pitch) do **not** allow the rotating crown to remain in one location as it may lead to vessel damage. Continue to maintain a maximum travel rate of 1 cm per second.
- **Maximum total treatment time should not exceed 5 minutes.** If maximum total treatment time exceeds 5 minutes, the OAD shaft, crown, and VIPERWIRE guide wire may begin to exhibit signs of wear and result in a device malfunction and possible injury to patient. A team member should track run time during use to verify total run time is not exceeded.
- Do **not** advance or retract the rotating crown by advancing the OAD sheath or handle. Buckling of the VIPERWIRE guide wire may occur resulting in vessel perforation or vascular trauma. Always advance the rotating crown by using the crown advancer knob.
- Do **not** inject contrast solution into the OAD injection port. Device failure or patient harm may occur.
- Do **not** allow body parts or clothing to come into contact with rotating components as the OAD rotates at very high speeds. Physical injury to the user or entanglement of clothing with the crown may occur.

- The OAS was only evaluated in severely calcified lesions; therefore the scientific evidence to support use of the OAS to treat other types of lesions/patients is limited.

5. Precautions

- Do **not** use the OAD if there is damage to the OAD package or if the OAD has reached its shelf life expiration date.
- If using an adjustable hemostasis valve with the guide catheter, close the hemostasis valve to minimize blood loss from around the guide catheter while still allowing the OAD sheath to slide through the hemostasis valve. Avoid excessive tightening of the hemostasis valve to prevent damaging the OAD catheter sheath. When inserting or removing the OAD crown or drive shaft through the hemostasis valve, use care not to deform the drive shaft.
- If 1:1 movement is not observed, retract and re-advance the crown into the lesion. Repeat retracting and advancing the crown into the lesion until 1:1 movement is observed. If the knob and the crown are not moving together, the crown may be driven into the lesion with too much force and lengthening of the OAD driveshaft may occur on exiting the lesion.
- Follow standard institution atherectomy policies and procedures, including those related to anticoagulation and vasodilator therapy.
- Always use fluoroscopy while introducing and advancing the VIPERWIRE guide wire within a vessel.
- A temporary pacing lead may be necessary when treating lesions in the right coronary and circumflex arteries due to the possible occurrence of electrophysiological alternations.
- The risk of the occurrence of a dissection or perforation is increased in severely calcified lesions undergoing percutaneous treatment; therefore, on-site surgical back-up should be included as a clinical consideration..
- Do **not** kink or crush the saline tubing as this will reduce the flow of saline and VIPERSLIDE Lubricant to the OAD.
- Continually monitor and check the saline tubing and connections for leaks during the procedure.
- Do **not** rotate the crown while advancing or retracting the crown within a guide catheter. Damage to the guide catheter and/or OAD may occur.
- Ensure the OAD strain relief remains straight during atherectomy treatment. If the OAD strain relief does not remain straight, the shaft/sheath can kink. Do **not** sterilize the OAS pump. Sterilizing will damage the OAS pump. The OAS pump is intended to be used and maintained outside of the sterile field. See Section 10.3 for instructions on cleaning and disinfecting the OAS pump.
- Do **not** spin the crown when removing the OAD from the body as this can result in guide catheter or touhy damage.
- Patients with an ejection fraction (EF) of less than 25% were not evaluated in the ORBIT II clinical study.

Diamondback 360® Coronary Orbital Atherectomy System

6. OAS component storage and handling

6.1 Storage

Store all OAS components in a clean environment and away from humidity, magnets, and sources of electromagnetic interference (EMI). OAS performance may be affected if any OAS component is exposed to temperatures outside the range indicated on their individual package labels.

6.2 Handling

- Ensure that the OAD, the OAS pump, and the VIPERWIRE guide wire are within the storage and operating temperature range of 50 – 104° F (10 - 40° C). If the OAD, the OAS pump, or the VIPERWIRE guide wire are outside operating temperatures, the OAD, the OAS pump, or the VIPERWIRE guide wire may not function as intended.
- Additional coronary OAS components should be on hand in the event of damage to any of the components or to component packaging.
- Do not reuse or resterilize the OAD, VIPERWIRE guide wire or VIPERSLIDE Lubricant as these components are designed for single-use only.
- Do not use the OAD or the VIPERWIRE guide wire if their sterile package barriers are compromised or damaged.
- Do not use the OAD or OAS pump if either of them were dropped onto a hard surface, from a height at or greater than 12 in (30 cm), as the OAD or OAS pump may be damaged and may fail to operate properly.
- Do not use any OAS components after their use-by date or if the OAS components were subjected to temperatures exceeding their safe storage or handling temperature ranges.

7. Adverse events

Potential adverse events that may occur and/or require intervention include, but are not limited to:

- Allergic reaction to medication/media/device components
- Aneurysm
- Angina (ischemic chest pain)
- Arrhythmias
- Arteriovenous fistula
- Bleeding
- Bruising/hematoma
- Cardiac/cardiopulmonary arrest
- Cardiac/pericardial tamponade
- Cerebrovascular accident (CVA)
- Death
- Embolization, distal (air, tissue, thrombus, device)
- Emergent coronary artery bypass graft surgery (CABG)
- Failure to deliver the system to the intended locations
- Fever
- Heart failure/dysfunction
- Hemorrhage, requiring transfusion
- Hypotension/hypertension
- Infection
- Myocardial infarction
- Pain
- Pericardial effusion
- Pseudoaneurysm
- Restenosis of treated segment leading to revascularization
- Renal insufficiency/failure
- Shock (cardiogenic, hypovolemic)
- Slow flow or no reflow phenomenon
- Stroke
- Thrombus
- Vessel closure, abrupt
- Vessel injury, requiring surgical repair
- Vessel dissection, perforation, rupture, or spasm
- Vessel occlusion

8. Clinical study summary

The prospective, single arm, multi-center IDE study (ORBIT II) of the DIAMONDBACK 360 OAS was conducted to evaluate the safety and effectiveness of the OAS. Four hundred forty three (443) patients from 49 participating centers were enrolled in this study. The primary objectives of the study were to (1) demonstrate the safety of the OAS in treating subjects with *de novo*, severely calcified coronary lesions, and (2) to demonstrate that the OAS successfully facilitates stent deployment in severely calcified coronary lesions.

There were a total of 443 subjects enrolled with 440 subjects having OAD inserted. Three subjects were not treated with OAD because of not meeting angiographic criteria (2) or the OAD could not pass through the lesion (1). A summary of patient demographics is listed below in Table 2.

Table 2. Patient Demographics

Baseline Characteristic	Result
Age (years)	71.4 ± 0.5 (N=443)
Gender (male)	286/443 (64.6%)
Ethnicity	
Caucasian	389/443 (87.8%)
Black or African American	25/443 (5.6%)
Asian	9/443 (2.0%)
Hispanic or Latino	16/443 (3.6%)
Native American	1/443 (0.2%)
Other	3/443 (0.7%)
eGFR (mL/min/1.73 m ²)	75.8 ± 1.2 (N=441)
History of diabetes mellitus	160/443 (36.1%)
History of dyslipidemia	407/443 (91.9%)
History of hypertension	406/443 (91.6%)
History of angina	348/443 (78.6%)
Prior stroke/Transient ischemic attack	39/443 (8.8%)
Prior MI	99/443 (22.3%)
Prior CABG	65/443 (14.7%)
Smoker (current or former)	293/443 (66.1%)

eGFR = estimated glomerular filtration rate; MI = myocardial infarction;
CABG = coronary artery bypass graft

Vessel calcification, as determined by the Investigator, is reported in Table 3. The overall mean length of calcium treated was 28.6 ± 0.8 mm, ranging from 9.0 – 100 mm.

Table 3. Vessel Calcification

Characteristic	Subjects N=440
Subjects with calcification determined by angiography only	405/440 (92.0%)
Total length of calcium (including segmented) (mm)	
N	405
Mean \pm SE	28.6 ± 0.8
Min – Max	9.0 - 100.0
Subjects with calcium visible on both sides of the vessel	405/405 (100.0%)
Subjects with calcification determined by IVUS	35/440 (8.0%)
Maximum degree of calcium via IVUS (°)	
N	35
Mean \pm SE	295.0 ± 6.1
Min - Max	270.0 - 360.0

Post-OAD balloon angioplasty was utilized in 41.1% (181/440) of the cases in the ORBIT II clinical study based on Investigator's preference. Per the ORBIT II protocol, all subjects required at least one stent to be placed after treatment with OAD.

The safety of the OAS was measured by a primary safety endpoint consisting of a composite of freedom from MACE (defined as cardiac death, MI, and TVR) at 30 days post index procedure. Among the 443 enrolled subjects, 46 subjects experienced 30-day post-procedural MACE events, 5 subjects were censored for 30-day post-procedural MACE event data, and 392 subjects were free from 30-day post-procedural MACE events for a final event free rate of 89.6%. Table 4 summarizes the Primary Safety Endpoint.

Table 4. Primary Safety Endpoint (30-day MACE)

Primary Safety Endpoint	% [95% CI] ¹	Hypothesis ²
Freedom from MACE within 30 days post-procedure ³	89.6% [86.7%-92.5%] ⁴	H ₀ : $\pi_s \leq 83\%$ H _A : $\pi_s > 83\%$
¹ Kaplan-Meier method used to obtain estimate of freedom from MACE. Peto's method used to obtain the 95% confidence interval for the estimate. ² π_s is the probability of freedom from MACE within 30 days of the procedure of OAS device treatment. ³ Freedom from MACE within 30 days post-procedure includes all subjects where the guide wire crossed the lesion. ⁴ Study conclusions do not change for the worst-case analysis in which all subjects with missing primary safety endpoint data, and those without post-procedural CK-MB and troponin data, are treated as having 30-day MACE events.		

A time to event analysis of the cumulative MACE rate (along with each component that comprises MACE) and the thrombosis rate at 30 days and annually are presented in Table 5.

Table 5. Cumulative Thrombosis and MACE Rates through 2-Year Follow-up

	Number of days post index procedure		
	30	365	730
Number of Subjects with Completed Visits	430	215	47
Thrombosis Event Rate	0.2%	0.2%	0.2%
MACE Event Rate	10.4%	18.3%	23.8%
Cardiac Death Event Rate	0.2%	4.4%	4.4%
TVR/TLR Event Rate	1.4%	6.3%	10.2%
MI Event Rate	9.5%	11.6%	11.6%

Procedural success was measured by the success in facilitating stent delivery, to the target lesion, with <50% residual stenosis and without in-hospital MACE. Final percent stenosis, as well as other procedural parameters, were evaluated by an independent Angiographic Core Laboratory. Procedural success occurred in 391 of 440 evaluable patients (i.e., patients in whom the study guide wire crossed the lesion and treatment with the OAD was inserted). The observed rate of procedural success was 88.9%. Table 6 summarizes the Primary Effectiveness Endpoint.

Table 6. Primary Effectiveness Endpoint

Primary Effectiveness Endpoint	% [95% CI] ¹	Hypothesis ²
Procedural Success	88.9% [85.5%-91.6%] ³	H ₀ : $\pi_e \leq 82\%$ H _A : $\pi_e > 82\%$
¹ Clopper-Pearson Exact two-sided 95% confidence interval. ² π_e is the probability of the procedural success for OAS device measured by the success in facilitating stent delivery with < 50% residual stenosis and without in-hospital MACE. ³ Study conclusions do not change for the worst-case analysis in which all subjects with missing primary effectiveness endpoint data, and those without post-procedural CK-MB and troponin data, are treated as having 30-day MACE events.		

Table 7 summarizes the components of the primary effectiveness endpoints.

Table 7. Primary Effectiveness Endpoint Components

Criteria	Subjects
Subjects with study guide wire crossing lesion and OAD inserted	N=440
Procedural Success	391/440 (88.9%)
Stent delivered	
Yes	430/440 (97.7%)
No	10/440 (2.3%)
Residual stenosis (%)	
< 50% Residual Stenosis	434/440 (98.6%)
≥ 50% Residual Stenosis	6/440 (1.4%)
In hospital MACE	
Yes	43/440 (9.8%)
No	397/440 (90.2%)
Cardiac Death	
No	439/440 (99.8%)
Yes	1/440 (0.2%)
MI	
No	399/440 (90.7%)
Yes	41/440 (9.3%)
Target Vessel Revascularization ¹	
No	437/440 (99.3%)
Yes	3/440 (0.7%)
¹ Includes Target Lesion Revascularizations	

Table 8 summarizes all serious adverse events observed through 30 days during the ORBIT II study.

Table 8. Summary of SAEs through 30 Days

SAEs through 30 days	Subjects N=443	
	Subjects n (%)	Events N
Cardiovascular Disorders	60 (13.5%)	68
Acute MI, Q-wave	4 (0.9%)	4
Acute MI, non Q-wave	39 (8.8%)	39
Angina Pectoris	2 (0.5%)	2
Angina pectoris	2 (0.5%)	2
Atrial fibrillation	2 (0.5%)	2
Atrioventricular block, II degree	1 (0.2%)	1
Cardiac/pericardial tamponade	4 (0.9%)	4
Cardiogenic shock	2 (0.5%)	2
Chest pain	2 (0.5%)	2
Endocarditis	1 (0.2%)	1
Non-target vessel revascularization	1 (0.2%)	1
PEA arrest	1 (0.2%)	1
Pericarditis	1 (0.2%)	1
Shock (Acute RV dysfunction and acute blood loss hypovolemic)	1 (0.2%)	1
Sick sinus syndrome	1 (0.2%)	1
Ventricular fibrillation	2 (0.5%)	2
Ventricular tachycardia	1 (0.2%)	1
Ventricular tachycardia/ventricular fibrillation	1 (0.2%)	1
Angiographic Complications	7 (1.6%)	7
Coronary artery embolism of air, plaque, thrombosis, or debris	3 (0.7%)	3
Slow flow or no reflow phenomena	3 (0.7%)	3
Thrombosis formation at site of treated lesion	1 (0.2%)	1
Vascular Disorders	11 (2.5%)	11
Neurologic/Psychiatric Disorders	4 (0.9%)	4
Respiratory/Thoracic Disorders	7 (1.6%)	9
Digestive Disorders	6 (1.4%)	6
Renal/Genitourinary Disorders	2 (0.5%)	2
Death (No disorder specified)	2 (0.5%)	2

SAEs through 30 days	Subjects N=443	
	Subjects n (%)	Events N
Cardiac death	1 (0.2%)	1
Non-cardiac death	1 (0.2%)	1
Other Disorders	5 (1.1%)	5
Any Adverse Event	91 (20.5%)	114

Table 9 and Table 10, respectively, summarize the presence and types of dissections and perforations as assessed by the Angiographic Core Laboratory.

Table 9. Summary of Dissections at Index Procedure

Dissection	Subjects N=443
Coronary vessel dissection present on subjects treated with OAD	52/443 (11.7%)
Type: A	9/52 (17.3%)
Type: B	22/52 (42.3%)
Type: C	8/52 (15.4%)
Type: D	4/52 (7.7%)
Type: E	1/52 (1.9%)
Type: F	1/52 (1.9%)
Type: Not Analyzable	7/443 (1.6%)
Coronary vessel dissection present on subjects not treated with OAD	1/443 (0.2%)
Non-coronary, Aortic Root dissection present on subjects treated with OAD	2/443 (0.5%)
Non-coronary, possible Aortic Cusp dissection present on subjects treated with OAD	1/443 (0.2%)

Table 10. Summary of Perforations at Index Procedure

Perforation	Subjects N=443
Coronary vessel perforation present on subjects treated with OAD	8/443 (1.8%)
Type: I (fully contained)	0/8 (0.0%)
Type: II (limited extravasation)	2/8 (25.0%)
Type: III (brisk extravasation)	5/8 (62.5%)
Type: cavity spilling	0/8 (0.0%)
Type: Not Analyzable	1/8 (12.5%)
Non-coronary right ventricle vessel perforation present on subjects treated with OAD	1/443 (0.2%)

Table 11 summarizes the first observed occurrence of the dissection or perforation as assessed by the Angiographic Core Laboratory. Note: There is a possibility of dissection or perforation following OAS use.

Table 11. Summary of Dissections and Perforations by Occurrence

Dissection First Identified	Subjects N=52
Prior to OAS	8/52 (15.4%)
Pre-OAS/post-balloon	0/52 (0.0%)
Post-OAS	24/52 (46.2%)
Post-OAS #1/post-balloon/pre-OAS #2	1/52 (1.9%)
Post-OAS/pre-stent/post-balloon	7/52 (13.5%)
Post-stent	11/52 (21.2%)
Post-stent/post-balloon	0/52 (0.0%)
Not Analyzable	1/52 (1.9%)
Perforation First Identified	Subjects N=8
Prior to OAS	0/8 (0.0%)
Pre-OAS/post-balloon	0/8 (0.0%)
Post-OAS	4/8 (50.0%)
Post-OAS/pre-stent/post-balloon	0/8 (0.0%)
Post-stent	4/8 (50.0%)
Post-stent/post-balloon	0/8 (0.0%)
Not Analyzable	0/8 (0.0%)

Table 12 summarizes serious clinical sequelae (i.e., death, MI, cardiac tamponade, stroke/CVA, shock, atrial fibrillation, in-stent thrombosis, emergent CABG treatment, or hypotension requiring additional medications) associated with dissections. Table 13 summarizes serious clinical sequelae associated with perforations. These tables also include the identity of “non-coronary” structures that were dissected or perforated.

Table 12. Summary of Subjects with Serious Adverse Events Related to Device/Procedure by Dissection Type

Dissection Type	Number of Subjects	Number of Subjects with Dissections and SAEs Related to Device/Procedure	SAE Summary for Subjects with Dissections ¹
Dissection Rate (All Types)	55/443 (12.4%)	14/55 (25.5%)	
Coronary vessel dissection present on subjects treated with OAD	52/443 (11.7%)	14/52 (26.9%)	
Type: A	9/52 (17.3%)	3/14 (21.4%)	MI (2), in-stent thrombus (1), hypotension (1)
Type: B	22/52 (42.3%)	4/14 (28.6%)	MI (4); emergent CABG treatment (1)
Type: C	8/52 (15.4%) ²	1/14 (7.1%)	MI (1)
Type: D	4/52 (7.7%)	3/14 (21.4%)	MI (3); stroke (1); tamponade (1)
Type: E	1/52 (1.9%)	0/14 (0.0%)	
Type: F	1/52 (1.9%)	1/14 (7.1%)	MI (1)
Type: Not Analyzable	7/52 (13.5%)	2/14 (14.3%)	MI (2); A-fib (1)
Coronary vessel dissection present on subjects not treated with OAD	1/443 (0.2%)	0/1 (0.0%)	
Non-coronary vessel dissection present on subjects treated with OAD – Aortic Root Dissections	2/443 (0.5%) ²	1/2 (50.0%)	MI (1)
Non-coronary vessel dissection present on subjects treated with OAD – Aortic Cusp Dissections	1/443 (0.2%)	0/1 (0.0%)	
<p>1 Some subjects had more than one SAE associated with the dissection event. In addition to MI, the following events also occurred:</p> <ul style="list-style-type: none"> • Stroke (005-002) • CABG (007-030) • Thrombus (027-008) • A-fib (009-026) • Hypotension (015-006) • Tamponade (018-003) 			
<p>2 One subject (022-001) was noted by the Angiographic Core Laboratory to have both a Type C dissection in the target vessel and a non-coronary aortic root dissection. Therefore, it is included under both types of dissections. The SAE reported for this subject is included in the reporting of SAEs in both associated columns.</p>			

Table 13. Summary of Subjects with Serious Adverse Events Related to Device/Procedure by Perforation Type

Perforation Type	Number of Subjects	Number of Subjects with Perforations and SAEs Related to Device/Procedure	SAE Summary for Subjects with Perforations ¹
Perforation Rate (All Types)	9/443 (2.0%)	7/9 (77.8%)	
Coronary vessel perforation present on subjects treated with OAD	8/443 (1.8%)	6/8 (75.0%)	
Type: I	0/8 (0.0%)	0/6 (0.0%)	
Type: II	2/8 (25.0%)	2/6 (33.3%)	MI (1); tamponade (1); stroke (1)
Type: III	5/8 (62.5%)	3/6 (50.0%)	Cardiac death (2); MI (2); tamponade (2); shock (1)
Type: Cavity spilling	0/8 (0.0%)	0/6 (0.0%)	
Type: Not Analyzable	1/8 (12.5%)	1/6 (16.7%)	MI (1); emergent CABG treatment + A-fib (1)
Non-coronary vessel perforation present on subjects treated with OAD – Right ventricle perforation	1/443 (0.2%)	1/1 (100%)	Tamponade (1)
¹ Some subjects may have had more than one SAE associated with the perforation event. <ul style="list-style-type: none"> • Shock (044-003), • Tamponade (007-015, 024-019, 009-018, 015-004) • A-fib & CABG (009-044) • Stroke (037-002) 			

9. Equipment, set up, and test

9.1. Equipment

In addition to OAS components, equip the operating room with the following:

- Guide catheter - see Table 1 for guide catheter size recommendations
- Standard IV pole with five wheels and a 20 inch diameter base
- 1000 mL bag of sterile normal saline
- Fluoroscopic imaging equipment
- Standard 110 V hospital grade, electrical wall outlet
- Other equipment, as needed, for interventional procedures

9.2. OAS Pump set up

1. Use the IV pole screw clamp to attach the OAS pump to a standard IV pole making sure to attach the OAS pump to the IV pole at a distance not greater than 60 in (153.0 cm) from the floor to the top edge of the OAS pump.
2. Hang the low saline level sensor and cord, by the closed loop, from the horizontal arm of the standard IV pole.
3. Plug the low saline level sensor connector into the back of the OAS pump.
4. Verify that the power cord is connected to the back of the OAS pump.
5. Insert the other end of the power cord into the electrical wall outlet.

9.3. Preparing the VIPERWIRE Advance Coronary Guide Wire

1. While using sterile techniques, open the VIPERWIRE guide wire packaging pouch and remove the packaging tube.
2. Remove the VIPERWIRE guide wire and VIPERWIRE guide wire torquer from the packaging tube as follows:
 - a. Locate the proximal VIPERWIRE guide wire retainer on the inside of the packaging tube. This will expose the proximal end of the VIPERWIRE guide wire.
 - b. Removing the VIPERWIRE guide wire – distal end first: advance the proximal end of the VIPERWIRE guide wire into the packaging tube. This will expose the distal end and spring tip of the VIPERWIRE guide wire. Grasp the exposed distal end of the VIPERWIRE guide wire and gently pull the VIPERWIRE guide wire out of the packaging tube. Use care to

not stretch or damage the spring distal tip while removing the VIPERWIRE guide wire from the packaging tube.

- c. Removing the VIPERWIRE guide wire – proximal end first: Grasp the exposed proximal end of the VIPERWIRE guide wire and gently pull the VIPERWIRE guide wire out of the packaging tube. Use care to not stretch or damage the spring distal tip while removing the VIPERWIRE guide wire from the packaging tube.

9.4. Initializing the atherectomy procedure

1. Gain vessel access using the physician's preferred methodology.
2. Access the treatment site with a guide catheter.
3. Use angiography to locate, visualize, and evaluate the coronary artery lesion.
4. Approach and cross the lesion, with the VIPERWIRE guide wire, using the physician's preferred methodology.

Figure 4. OAS pump control panel

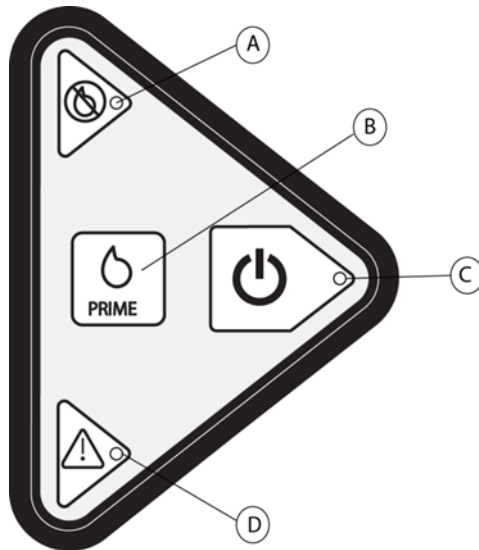

- A. Low saline red LED indicator
 - B. Prime button
 - C. Start button and green LED indicator
 - D. Status yellow LED indicator
-

9.5. Preparing the bag of saline and VIPERSLIDE Lubricant

1. Ensure that the OAS pump is powered off by pressing the **Master Power** switch on the back of the OAS pump to off and ensure that no LEDs are illuminated on the OAS pump panel (Figure 4).
2. Prepare a full 1000 mL bag of normal saline solution with VIPERSLIDE Lubricant. Refer to the VIPERSLIDE Lubricant Instructions for Use for lubricant preparation instructions.
3. Hang the prepared saline bag with VIPERSLIDE Lubricant from the low saline level sensor on the standard IV pole.

Caution: Do **not** use glass bottles for the saline solution with VIPERSLIDE Lubricant or hang multiple saline bags from the low saline level sensor as this will disable the Low Saline Information signal.

Figure 5. Placing the saline tubing within the OAS pump

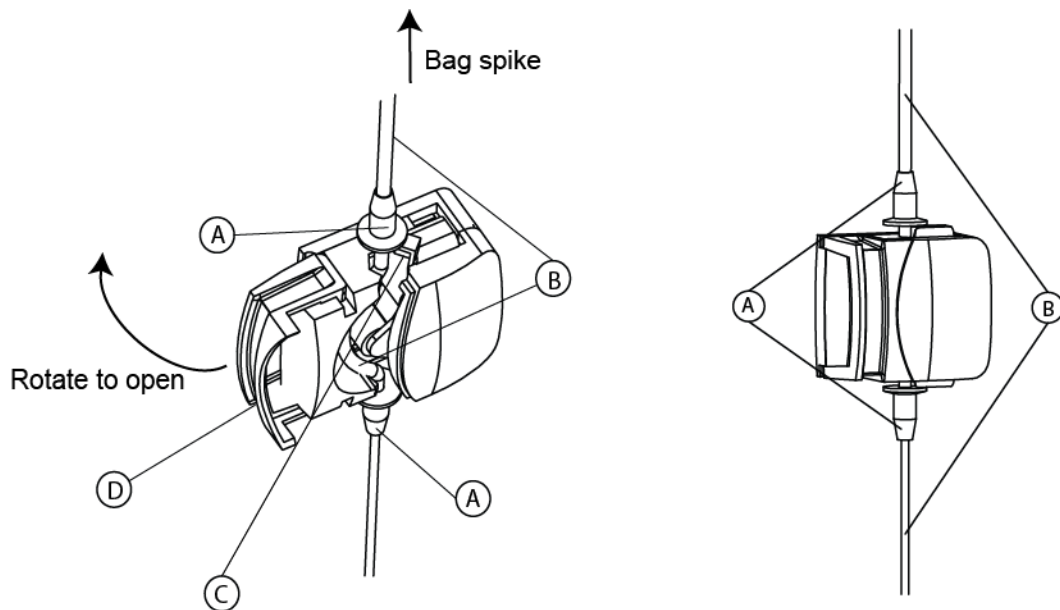

- A. Saline tubing positioners
- B. Saline tubing
- C. V-guides
- D. Pump door

9.6. Connecting the OAD to the OAS pump

Remove the sterile saline tubing from the OAD package and pass the saline bag spike end of the saline tubing out of the sterile field. Connect the other end of the saline tubing luer to the OAD luer. Additionally, pass the OAD power cord out of the sterile field.

Perform the following:

1. Connect the saline tubing to the saline bag with VIPERSLIDE Lubricant using standard institution procedures.
2. Open the door, located on the front of the OAS pump, by rotating the door in the direction of the arrow (Figure 5).
3. Place the saline tubing in between the saline tubing positioners that are affixed to the saline tubing, into the top and bottom saline tubing V-guides (Figure 5).
4. While closing the door, verify that there is no pinching of the saline tubing and ensure that there is slack in the saline tubing between the OAS pump and saline bag with VIPERSLIDE Lubricant.
5. Verify that the saline tubing is properly inserted into the saline tubing V-guides and that there are no kinks or damage to the saline tubing.
6. Press the **Master Power** switch, on the back of the OAS pump, and verify that the red or yellow LED is illuminated on the OAS pump control panel.
7. Connect the OAD power cord to the OAS pump.
8. Remove the drive shaft from the dispenser coil.
9. Purge air from the OAD and the saline tubing as follows:
 - a. Verify that the saline tubing is connected to the OAD.
 - b. Press the green **Start** button on the OAS pump control panel to start saline flowing through the saline tubing. Verify that the green LED illuminates.
 - c. Press and hold the **Prime** button on the OAS pump control panel to purge air from the saline tubing. Continually pressing the **Prime** button will pump saline through the tubing at an increasing flow rate. Releasing the **Prime** button will decrease the flow to the low flow rate after three seconds.
 - d. Verify that saline is exiting from the OAD sheath near the crown.
 - e. Continue priming to ensure there are no air bubbles within the saline tubing and use standard hospital procedures to aspirate or purge air from the lines.
 - f. After verifying there are no air bubbles within the saline tubing, discontinue priming.

9.7. Testing the OAD

9.7.1. Testing OAD crown advancement

Before inserting any portion of the OAD into the body, ensure that axial movement of the OAD crown advancer knob will produce smooth travel of the crown.

Caution: Do **not** rotate the crown during this test.

1. Ensure that the crown advancer knob is in the unlocked position as this will allow free axial travel of the crown advancer knob.
2. While visually monitoring the crown, slowly move the crown advancer knob in a back and forth motion. The maximum travel of the crown advancer knob, and the corresponding maximum travel of the shaft tip, is 3.3 inches (8.4 cm).

9.7.2. Testing the OAD crown rotation

1. Push the crown advancer knob fully proximal, away from the nose of the handle, and release the guide wire brake before threading the VIPERWIRE guide wire through the OAD drive shaft.
2. Grasp the proximal end of the VIPERWIRE guide wire and thread the VIPERWIRE guide wire through the opening in the OAD drive shaft distal tip.

Warning: Do **not** operate the OAD if there is a bend, kink, or tight loop in the VIPERWIRE guide wire. A bend, kink, or tight loop in the VIPERWIRE guide wire may cause damage to and malfunctioning of the OAD during use.

3. Continue feeding the VIPERWIRE guide wire into the OAD drive shaft until the guide wire appears at the rear of the OAD.

Caution: If using an adjustable hemostasis valve with the guide catheter, close the hemostasis valve to minimize blood loss from around the guide catheter while still allowing the OAD sheath to slide through the hemostasis valve. Avoid excessive tightening of the hemostasis valve to prevent damaging the OAD catheter sheath. When inserting or removing the OAD crown or drive shaft through the hemostasis valve, use care not to deform the drive shaft.

4. Lock the VIPERWIRE guide wire in place by pressing down on the guide wire brake lever as the crown will not spin if the guide wire brake is unlocked.
5. Verify that saline is still flowing freely out of the saline sheath tip. Verify that the saline tubing is properly connected to the saline bag, that the saline tubing routes correctly through the saline tubing guides, and that the saline tubing is properly connected to the OAD.
6. Press and release the **On/Off** button located on top of the crown advancer knob to activate crown rotation. The OAD is preset to low speed, and the illuminated LED on the OAD will indicate that the OAD is operating at low speed.
7. Check that the flow of saline is increasing and that the shaft and crown are beginning to rotate.
8. Immediately press and release the **On/Off** button to stop the shaft and crown from rotating and to complete the test.

10. OAS directions for use

10.1. Performing the atherectomy procedure

1. Ensure that the OAD guide wire brake lever is open (in the up position).
2. Advance the OAD drive shaft over the VIPERWIRE guide wire and through the hemostasis valve while keeping VIPERWIRE guide wire placement stationary.
3. While using fluoroscopy, gently advance the OAD crown over the VIPERWIRE guide wire to a position approximately 1 cm proximal to the lesion. Verify that the OAD distal tip is not within the lesion when the crown and drive shaft begin to rotate.
4. Inject contrast medium, through a port in the hemostasis valve, to verify that the size of the crown is compatible with the treatment area diameter (see Appendix B).
5. Verify that the VIPERWIRE guide wire spring tip is distal to the lesion and is not in danger of coming in contact with the rotating crown and drive shaft tip.

Caution: Maintain at least 5 mm between the proximal end of the VIPERWIRE guide wire spring tip and the OAD drive shaft tip to prevent contact of the drive shaft tip with the guide wire spring tip. Further advance the VIPERWIRE guide wire, as necessary, to maintain the 5 mm minimum distance.

6. Push down on the VIPERWIRE guide wire brake lever to engage the brake. The crown will not spin if the guide wire brake is not locked.
7. Press and release the **On/Off** button on top of the crown advancer knob to activate crown rotation. The OAD is preset to low speed, and the illuminated LED on the OAD will indicate that the OAD is operating at low speed.

Warning: Initial treatment for each lesion must start at low speed.

Caution: Continually monitor the saline fluid levels during the procedure. Continual infusion of saline and VIPERSLIDE Lubricant is critical for safe coronary OAS operation.

8. Audibly verify that the OAD drive shaft and crown are rotating at a stable speed as indicated by the OAD frequency (pitch) stabilizing following the 2 second ramp up in speed.
9. Slowly advance the crown advancer knob to begin atherectomy of the lesion at a maximum travel rate of 1 cm per second. Using fluoroscopy, continually

verify that the crown and the crown advancer knob are moving 1:1 with one another. Ensure that the OAD remains horizontal during the procedure to minimize saline leakage from the OAD handle.

10. Using a series of intermittent treatment intervals and rest periods, slide the crown advancer knob to move the crown back and forth across the lesion always returning to the proximal side of the lesion when the interval set is complete.

Warning: Once OAD has reached full speed (as indicated by a stable pitch) do **not** allow the rotating crown to remain in one location as it may lead to vessel damage. Continue to maintain a maximum travel rate of 1 cm per second.

For every 30 seconds of treatment, a rest period of equal time is recommended with a maximum treatment time of **5 minutes** per OAD. The OAS pump will emit a beep after every 25 second interval of treatment time.

Warning: Maximum total treatment time should not exceed 5 minutes. If maximum total treatment time exceeds 5 minutes, the OAD shaft, crown, and VIPERWIRE guide wire may begin to exhibit signs of wear and result in a device malfunction and possible injury to patient. A team member should track run time during use to verify total run time is not exceeded.

10.1.1. Replacing the bag of saline and VIPERSLIDE Lubricant

The low saline level sensor triggers if there is less than 200 mL (+/- 100 mL) remaining in the bag of saline and VIPERSLIDE Lubricant. Perform the following to replace the bag of saline and VIPERSLIDE Lubricant:

1. Ensure that the pump is stopped by pressing the green **Start** button on the OAS pump control panel and verify that the green LED, on the OAS pump control panel, is not illuminated.
2. Prepare a new 1000 mL bag of normal saline solution with VIPERSLIDE Lubricant. Refer to the VIPERSLIDE Lubricant Instructions for Use for lubricant preparation instructions.
3. Remove the empty bag of saline and VIPERSLIDE Lubricant from the low saline level sensor on the IV pole.
4. Hang the new bag of saline and VIPERSLIDE Lubricant from the low saline level sensor on the standard IV pole.

Caution: Do not use glass bottles for the saline solution with VIPERSLIDE Lubricant or hang multiple saline bags from the low

saline level sensor as this will disable the Low Saline Information signal.

5. Remove the bag spike from the empty bag of saline and VIPERSLIDE Lubricant and spike the new bag of saline and VIPERSLIDE Lubricant.
6. Power on the OAS pump by pressing the green **Start** button on the OAS pump control panel.
7. Ensure that no air was introduced into the saline tubing.

10.1.2. Replacing the OAD

If the OAD needs replacing, perform the following:

1. Stop the rotating crown and drive shaft by pressing and releasing the **On/Off** button on top of the crown advancer knob.
2. Disconnect the OAD power cord from the OAS pump.
3. Leave the guide catheter and the VIPERWIRE guide wire in place, release the guide wire brake on the OAD, and retract the OAD sheath and drive shaft, from the guide catheter, while monitoring and maintaining the current guide wire position.
4. Power off the OAS pump by pressing the green **Start** button on the OAS control panel to stop saline from flowing through the saline tubing and verify that the green LED, on the OAS pump control panel, is not illuminated.
5. Disconnect the saline tubing from the OAD currently in use and set aside for use with the replacement OAD.
6. Obtain a new replacement OAD and remove the new replacement OAD from the package.
7. First, attach the existing saline tubing to the new replacement OAD, then connect the new replacement OAD power cord to the OAS pump.
8. Press the green **Start** button on the OAS pump control panel to start the saline flowing through the saline tubing and verify that the green LED illuminates.
9. Purge the air from the OAD. Refer to Section 9.6, step 9.
10. Load the new replacement OAD drive shaft over the existing VIPERWIRE guide wire.
11. Test the OAD crown advancement per the instructions in Section 9.7.1.
12. Test the OAD crown rotation per the instructions in Section 9.7.2.

10.2. Completing the atherectomy procedure

To complete the atherectomy procedure, perform the following:

1. While the crown is spinning, retract the crown and drive shaft proximal to the lesion.
2. Stop the OAD crown and drive shaft rotation by pressing and releasing the **On/Off** button on top of the crown advancer knob.
3. Carefully remove the OAD drive shaft and crown from the guide catheter and discard the OAD according to standard hospital protocol.

Caution: Do **not** spin the crown when removing the OAD from the body as this can result in damage to the guide catheter or touhy.

4. Press the green **Start** button on the OAS pump control panel to stop saline from flowing through the saline tubing and verify that the green LED is not illuminated. Turn off the OAS pump at the **Master Power** switch on the back of the OAS pump.
5. Remove and dispose of the VIPERWIRE guide wire and guide catheter according to standard hospital procedures.
6. Treat the puncture site according to standard interventional procedure protocol.

Warning: The OAD, VIPERWIRE guide wire and VIPERSLIDE Lubricant are designed for single patient use only and should **not** be reused or re-sterilized. The saline tubing and partially-used bag of saline and VIPERSLIDE Lubricant are designed for single patient use only and should not be stored or reused. Discard devices according to hospital guidelines at the end of the procedure.

10.3. Maintaining the OAS Pump

The OAS pump does not require routine maintenance, periodic maintenance, or calibration. CSI recommends inspection of the OAS pump in accordance with the hospital's standard biomedical engineering department protocol. The pump has been designed to function for 875 hours minimum, with 350 hours of minimum OAD use, which equates to 5 years. Contact CSI Customer Service if there are questions about the OAS pump function or performance.

10.3.1. Cleaning the OAS Pump

Clean the OAS pump immediately after each use by following the steps below:

Caution: Ensure that the OAS pump is powered off at the **Master Power** switch on the back of the OAS pump and disconnect the OAS pump from wall power before cleaning the OAS pump.

Caution: Do **not** immerse the OAS pump into fluids. Do **not** use solvents or abrasive cleaners to clean the OAS pump as these may damage the OAS pump and OAS pump components.

Caution: Completely dry the OAS pump before reconnecting the OAS pump to wall power and powering on the OAS pump.

1. Prepare an enzymatic detergent, such as EnzoI[®], per manufacturer's directions.
2. Thoroughly wipe down the OAS pump, using a clean soft cloth that has been dampened with the prepared detergent, until all visible soil is removed.
3. Thoroughly rinse the OAS pump, using a clean soft cloth that has been dampened with lukewarm tap water.
4. Dry the OAS pump using a clean, soft cloth; and, if available, filtered, pressurized air at ≤ 40 psi.

10.3.2. Disinfecting the OAS Pump

Disinfect the OAS pump after each use by following the steps below:

Caution: Ensure that the OAS pump is powered off at the **Master Power** switch on the back of the OAS pump and disconnect the OAS pump from wall power before disinfecting the OAS pump.

Caution: Do **not** immerse the OAS pump into fluids. Do **not** use solvents or abrasive disinfectants to disinfect the OAS pump as these may damage the OAS pump and OAS pump components.

Caution: Completely dry the OAS pump before reconnecting the OAS pump to wall power and powering on the OAS pump.

1. Open a fresh, sterile wipe that is pre-saturated with 70% Isopropyl Alcohol (IPA) or prepare a sterile gauze/wipe by pouring or soaking it with 70% IPA. Wring any excess IPA from the gauze/wipe, ensuring that the gauze/wipe remains saturated, but not dripping, with IPA.
2. Thoroughly wipe all surfaces on the front face of the OAS pump. Concentrate wiping the seams and crevices of the OAS pump head door, around the edges of the lettering, and around the OAS pump control panel. Continue to wipe these surfaces for a minimum of one (1) minute. Discard the gauze/wipe. Repeat step #1.
3. Open the OAS pump head door. Using the prepared gauze/wipe, thoroughly wipe the edge of the OAS pump head door on both sides of the closure seam. Continue to wipe these surfaces for a minimum of one (1) minute. Discard the gauze/wipe. Repeat step #1.
4. Thoroughly wipe all surfaces on the front face of the OAS pump and the edge of the OAS pump head door on both sides of the closure seam. Continue to wipe these surfaces for a minimum of one (1) minute. Discard the gauze/wipe. Repeat step #1.
5. Continue to repeat this wiping process, as many times as necessary, to ensure that all surfaces remain wet with IPA for a minimum of ten (10) minutes.
6. Close the OAS pump door when disinfecting is complete.

10.4. Returning OAS components

Contact CSI Customer Service for returning OAS components. See the back of this instruction for use for CSI contact information.

11. Specifications

11.1. OAD specifications

Parameter	Value
Electrical cable length: OAD to OAS pump	3.4 m (11 ft)
Electrical connector type (device power)	Type CF applied Part –DC barrel (48 V DC)
Fluid connector type	Luer fitting
Tubing length (from saline bag to OAD)	3.7 m (12 ft)
Visual alerts	Speed indicators
Sterilization	Ethylene oxide (EtO) cycle
Storage temperature	10-40° C (50-104° F)
Operating temperature	10-40° C (50-104° F)
Shelf life	Two years
Operating life	5 minutes of total therapy time
Water Ingress Protection	IPX1: Protection against water ingress
Approximate saline flow rate	30 ml/min
<ul style="list-style-type: none"> • Prime button pressed, OAD not spinning 	20 ml/min
<ul style="list-style-type: none"> • OAD spinning on low speed 	
<ul style="list-style-type: none"> • OAD spinning on high speed 	17 ml/min
<ul style="list-style-type: none"> • OAD not spinning, prime button not pressed 	18 ml/min

11.2. OAS pump specifications

Parameter	Value
Volume	1950 cm ³ (119 in ³)
Height	20.3 cm (8.0 in)
Width	25.4 cm (10.0 in)
Weight	4.0 kg (8.9 lbs)
Electrical cable length: OAS pump to electrical outlet	6.1 m (20 ft)
Master Fuse	250 V 4A SLOW BLOW 014" x 1 - 1¼"
External housing	ABS Plastic
Electrical connector type (Main Power)	Mains Power Plug (100–240 V AC @ 50–60 Hz)
Audible alerts	Audible alerts for approximately every 25 sec of OAD spin time*
Visual alerts	Start button Low Saline Information Signal when ≤200 mL (± 100 mL) of 1000-mL bag of saline remaining
Storage temperature	10-40° C (50-104° F)
Operating temperature	10-40° C (50-104° F)
Operating life	875 hours minimum, with 350 hours of therapy minimum or 5 years
Water Ingress Protection	IPX1: Protection against water ingress

* Timer resets when OAD rotation stops.

12. OAS Pump Declaration of Conformity

CSI declares that the coronary OAS is in conformity with the requirements of: IEC 60601-1. The OAS pump is compatible for use in a standard catheter laboratory environment.

13. EMC Declaration

Medical electrical equipment needs special precautions regarding electromagnetic compatibility (EMC). Install and use medical electrical equipment according to the EMC information below:

- Do not have portable and/or mobile radio-frequency (RF) communications equipment within close proximity of medical electrical equipment as portable and mobile RF communications equipment can affect medical electrical equipment.
- Ensure that power frequency magnetic fields are at levels characteristic of a typical commercial or hospital environment.

Appendices

A. OAS troubleshooting

If issues with the OAD cannot be resolved in each of the situations below, replace the OAD and continue with the procedure. Contact CSI Customer Service for returning OAS components. See the back of the instructions for use for CSI contact information.

Issue number	Issue	Solution
1	The crown stops rotating during the procedure	<ol style="list-style-type: none"> 1. Immediately discontinue treatment. Stop the OAD from spinning, but leave the OAS pump running. 2. Verify that saline is flowing. 3. Check that the OAS pump green LED OAS pump on light is on and that the OAD green LED light is on. 4. Check to ensure that the OAS pump power cord is connected to the back of the OAS pump and that the OAD power cord is connected to the OAS pump. 5. Check that the OAD guide wire brake lever is in the down/locked position. 6. Retract the crown proximal to the lesion. Use fluoroscopy to analyze the situation prior to attempting a low speed spin of the crown.
2	Blood is backing up into the OAD	<ol style="list-style-type: none"> 1. Immediately discontinue treatment. Stop the OAD from spinning, but leave the OAS pump running. 2. Verify that the saline tubing is properly connected to the saline bag, that the saline tubing is routed correctly through the OAS pump saline tubing guides, and that the saline tubing is properly connected to the OAD. 3. If the saline tubing is properly

Issue number	Issue	Solution
		connected and blood continues to back into the OAD sheath, replace the OAD.
3	Crown rotational speeds are variable and will not stabilize	<ol style="list-style-type: none"> 1. Immediately discontinue treatment. 2. Stop the OAD from spinning, but leave the OAS pump running. 3. Verify that saline is flowing. 4. Verify VIPERSLIDE Lubricant is present in the saline bag. See the VIPERSLIDE Lubricant Instructions for Use for information. Verify that the saline tubing is properly connected to the saline bag, that the saline tubing is routed correctly through the OAS pump saline tubing guides, and that the saline tubing is properly connected to the OAD. 5. Verify that the crown advancer knob moves smoothly. 6. Retract the crown proximal to the lesion. Using a maximum travel rate of 1 cm/second, continue treatment on low speed.
4	The OAD stops spinning and both crown rotation speed indicator LEDs on the OAD handle are illuminated	Immediately discontinue treatment and replace the OAD.
5	The crown is not moving one-to-one with the crown advancer knob	<p>During start up in the vessel:</p> <ol style="list-style-type: none"> 1. Verify the Tuohy valve is not over-tightened. 2. Verify the crown advancer knob moves smoothly. 3. Retract the crown advancer knob

Issue number	Issue	Solution
		<p>until the crown moves with the knob.</p> <p>While spinning:</p> <ol style="list-style-type: none"> 1. Immediately discontinue treatment. Stop the OAD from spinning, but leave the OAS pump running. 2. Verify the Tuohy valve is not over-tightened. 3. Verify that the crown advancer knob moves smoothly. 4. Retract the crown advancer knob until the crown moves with the knob. 5. Verify that contrast media injections are not above 400 psi and are not occurring during crown rotation. 6. Engage and disengage the lesion using a maximum 1 cm/second travel rate while maintaining one-to-one crown to control knob movement.
6	The OAS pump will not power on and no LEDs are illuminated on the OAS pump control panel	<ol style="list-style-type: none"> 1. Ensure that the power cord is properly inserted into the power module on the back of the OAS pump and that the power cord is connected to a functioning wall power outlet. 2. Ensure that the Master Power switch, on the back of the OAS pump, is in the on position.
7	The OAS pump will not pump saline	<ol style="list-style-type: none"> 1. Ensure that the OAS pump is properly powered on – see Issue number 6. 2. Ensure that the saline bag and

Issue number	Issue	Solution
		<p>saline tubing (i.e. bag spike) are properly connected and a sufficient amount of saline is in the saline bag such that the low saline level sensor is not active and the red LED on the OAS pump control panel is not illuminated.</p> <ol style="list-style-type: none"> 3. Ensure that the OAS pump head is properly aligned with the OAS pump base. 4. Ensure that the saline tubing is routed correctly through the OAS pump saline tubing guides and that the OAS pump saline tubing door is closed. 5. Ensure that the yellow LED is off and the green LED is illuminated. If the green LED is not illuminated, press the green Start button and verify that the yellow LED is off and that the green LED illuminates.
8	The green (start) LED is illuminated, but the OAS pump does not pump and the yellow LED is illuminated as well	Contact CSI Customer Service at the phone number on the back of this instructions for use.
9	The OAS pump was running, but has stopped pumping and the yellow LED is illuminated	Press the Master Power switch, on the back of the OAS pump, to power off the OAS pump. Wait a few seconds and press the Master Power switch to power on the OAS pump.

Issue number	Issue	Solution
10	The low saline level sensor (red LED) is illuminated	<p>Note: The OAS pump will stop pumping saline and supplying power to the OAD 30 seconds after the low saline level sensor activates while the OAD is spinning.</p> <ol style="list-style-type: none"> 1. If there is less than 200 mL of saline left in the bag of saline and VIPERSLIDE Lubricant, replace the bag with a new 1000 mL bag of normal saline and VIPERSLIDE Lubricant solution. 2. Ensure that the bag of saline and VIPERSLIDE Lubricant is hanging freely from the saline bag open hook and that the low saline level sensor cord is properly inserted into the connector on the sensor and the connector on the back of the OAS pump. 3. Verify that the red low saline LED on the OAS pump control panel turns off and either the yellow LED or the green LED illuminates.
11	The OAS pump will not power on	<p>Note: The OAS pump is designed to stop pumping saline and cut the supply of power to the OAD if the OAS pump encounters internal errors, such as: improper OAS pump pumping speed, problems with the power supply, inadvertent opening of the saline tubing door, etc. If an internal error occurs, the green LED will turn off and the yellow LED will illuminate.</p> <ol style="list-style-type: none"> 1. Ensure that the saline tubing door is closed. 2. Attempt to restart the OAS pump

Issue number	Issue	Solution
		<p>by pressing the green Start button on the OAS pump control panel and verify that the green LED illuminates.</p> <p>3. If the OAS pump does not restart after completing the abovementioned steps, press the Master Power switch to power off the OAS pump. Wait a few seconds and press the Master Power switch to power on the OAS pump. Verify that the OAS pump powers on.</p>

B. Maximum orbit and resulting lumen diameter

The following table shows the maximum orbit and resulting lumen diameter for classic crown sizes, at incremental rotational speeds, for 20 passes (approximately 5 min of treatment time).

Note: A **pass** is defined as once out and back across the lesion. Orbit data presented are based on a 6 cm pass distance at a travel rate of 1 cm per second.

Minimum Reference Vessel Diameter* (mm)	Crown Size (mm)	Rotational Speed (rpm)	Maximum Lumen Diameter** (mm) Average +2 SD
2.00	1.25	80,000	1.64
		120,000	1.84
2.50	1.50	80,000	1.95
		120,000	2.16

SD = standard deviation

* The minimum reference vessel diameter (RVD) is based on the following ratio: Orbit at 20 passes/RVD = 0.80. Quantitative angiography is recommended to determine vessel diameter. The values in this table are for reference only.

**These lumens are based on in vitro test results at approximately 5 min of treatment time (20 passes) at a rate of approximately 1 cm per second of travel speed. Actual clinical results may vary.

C. Orbit performance

The following charts demonstrate typical orbit diameter vs. duration of operation (as measured in simulated calcified lesions.) These charts are for reference only. Actual orbit performance may vary.

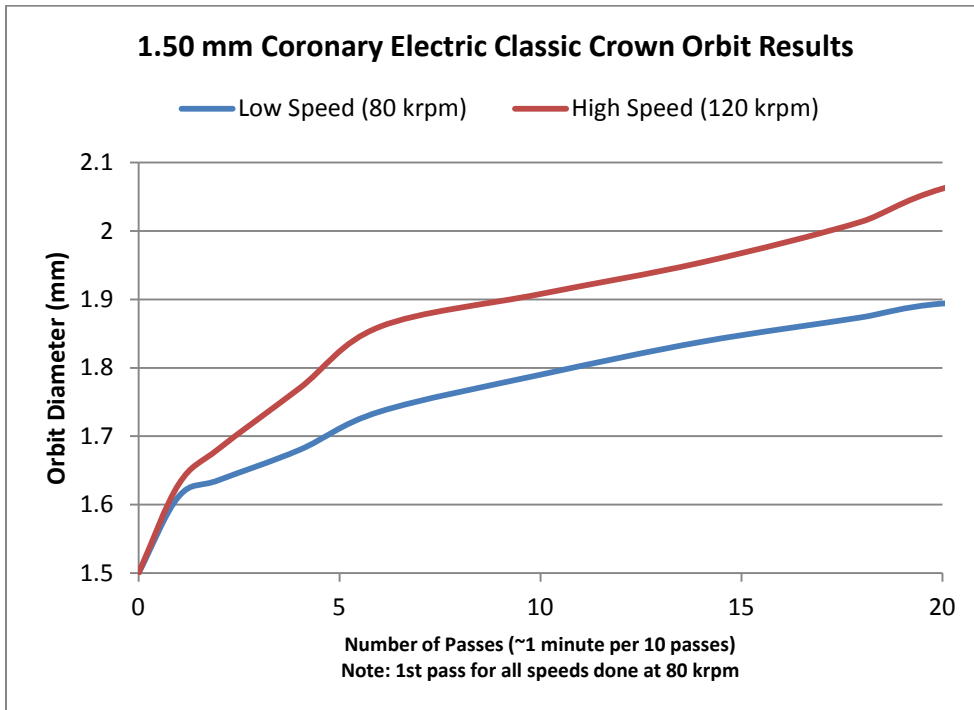
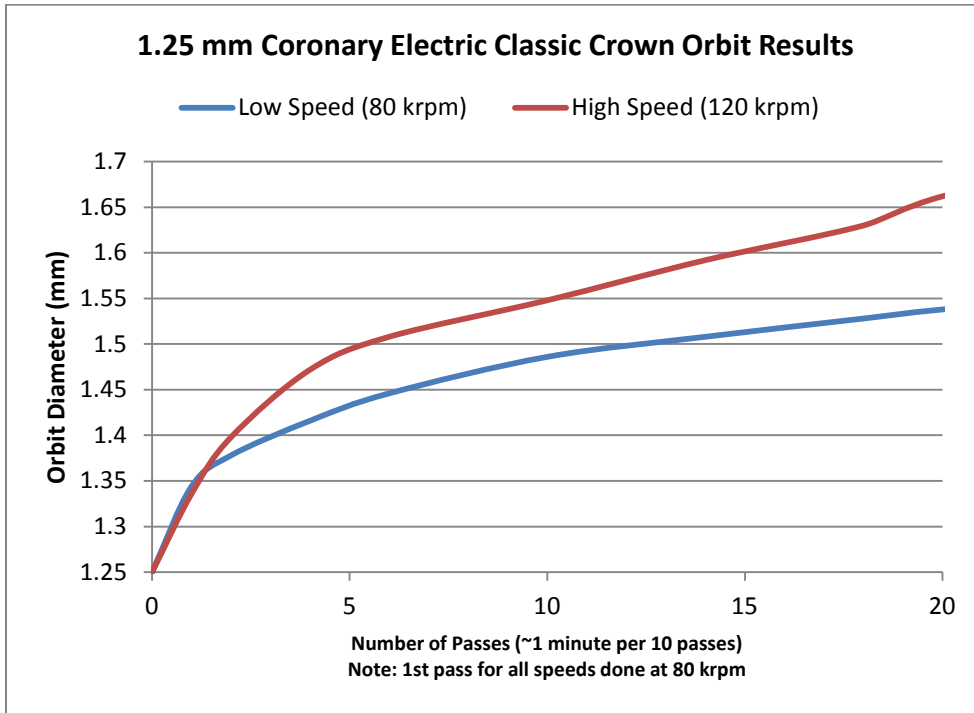



Manufacturer:

Cardiovascular Systems, Inc.

651 Campus Drive

St. Paul, MN 55112 USA

651-259-1600

1-877-CSI-0360

www.csi360.com

© Cardiovascular Systems, Inc. 2013

90267-01.A