

PHYSICIAN'S TECHNICAL MANUAL

**ACCOLADE™, ACCOLADE™ MRI,  
PROPONENT™, PROPONENT™ MRI,  
ESSENTIO™, ESSENTIO™ MRI,  
ALTRUA™ 2,  
FORMIO™, FORMIO™ MRI,  
VITALIO™, VITALIO™ MRI,  
INGENIO™, INGENIO™ MRI,  
ADVANTIO™**

**PACEMAKER**

Model L300, L301, L321, L310, L311, L331, L200, L201, L221, L210, L211, L231,  
L100, L101, L121, L110, L111, L131, S701, S702, S722, K278, K279, K272,  
K273, K274, K275, K276, K277, K172, K173, K174, K175, K176, K177, K062,  
K063, K064

**CAUTION:** Federal law (USA)  
restricts this device to sale by  
or on the order of a physician  
trained or experienced in  
device implant and follow-up  
procedures.

Boston Scientific Confidential. Unauthorized use is prohibited.

**LIT APPROVAL - INGENIO 1-2 MRI PTM US**

Approved

1124977 A

## Table of Contents

Additional Information.....	1
Device Description.....	1
Related Information.....	3
Indications and Usage.....	4
Contraindications.....	5
Warnings.....	5
Precautions.....	7
Supplemental Precautionary Information.....	21
Post-Therapy Pulse Generator Follow Up.....	21
Magnetic Resonance Imaging (MRI).....	22
Minimizing Pacemaker/S-ICD Interaction.....	25
Transcutaneous Electrical Nerve Stimulation (TENS).....	27
Electrocautery and Radio Frequency (RF) Ablation.....	28
Ionizing Radiation.....	30
Elevated Pressures.....	31
Potential Adverse Events.....	32
Mechanical Specifications.....	35
Items Included in Package.....	44
Symbols on Packaging.....	44
Characteristics as Shipped.....	48
X-Ray Identifier.....	50
Federal Communications Commission (FCC).....	51
Pulse Generator Longevity.....	52
Warranty Information.....	58
Product Reliability.....	58
Patient Counseling Information.....	59
Patient Handbook.....	60

Boston Scientific Confidential. Unauthorized use is prohibited.

**LIT APPROVAL - INGENIO 1-2 MRI PTM US**

Lead Connections.....	60
Implanting the Pulse Generator.....	63
Step A: Check Equipment .....	64
Step B: Interrogate and Check the Pulse Generator .....	64
Step C: Implant the Lead System .....	65
Step D: Take Baseline Measurements .....	66
Step E: Form the Implantation Pocket.....	68
Step F: Connect the Leads to the Pulse Generator.....	69
Step G: Evaluate Lead Signals.....	72
Step H: Program the Pulse Generator.....	74
Step I: Implant the Pulse Generator .....	75
Step J: Complete and Return the Implantation Form .....	76
Bidirectional Torque Wrench.....	76
Follow Up Testing .....	78
Predischarge Follow Up .....	79
Routine Follow Up .....	79
Explantation.....	80

#### **ADDITIONAL INFORMATION**

For additional reference information, go to [www.bostonscientific.com/ifu](http://www.bostonscientific.com/ifu).

#### **DEVICE DESCRIPTION**

This manual contains information about the ACCOLADE, PROPONENT, ESSENTIO, ALTRUA 2, FORMIO, VITALIO, INGENIO, and ADVANTIO families of implantable pacemakers, including the following types of pulse generators (specific models are listed in "Mechanical Specifications" on page 35):

- SR—single chamber pacemaker providing ventricular or atrial pacing and sensing
- DR—dual-chamber pacemaker providing ventricular and atrial pacing and sensing

**NOTE:** *Specific features discussed in this manual may not apply to all models. References to names of non-MRI devices also apply to the corresponding MRI devices. References to "ICD" include all types of ICDs (e.g., ICD, CRT-D, S-ICD).*

#### **Therapies**

These pulse generators provide bradycardia pacing and adaptive rate pacing to detect and treat bradyarrhythmias.

#### **Leads**

The pulse generator has independently programmable outputs and accepts one or more of the following leads, depending on the model:

- One IS-1<sup>1</sup> unipolar or bipolar atrial lead
- One IS-1 unipolar or bipolar right ventricular lead

**NOTE:** *Single-chamber devices will accept either an IS-1 atrial or an IS-1 ventricular lead.*

---

1. IS-1 refers to the international standard ISO 5841-3:2013.

**NOTE:** Use of a unipolar lead with an ImageReady pulse generator is inconsistent with the Conditions of Use required for MR Conditional status. Refer to the ImageReady MR Conditional Pacing System MRI Technical Guide for information about MRI scanning.

The pulse generator and the leads constitute the implantable portion of the pulse generator system.

**NOTE:** Use of Boston Scientific MR Conditional leads is required for an implanted system to be considered MR Conditional. Refer to the MRI Technical Guide for model numbers of pulse generators, leads, accessories, and other system components needed to satisfy the Conditions of Use.

#### **PRM System**

These pulse generators can be used only with the ZOOM LATITUDE Programming System, which is the external portion of the pulse generator system and includes:

- Model 3120 Programmer/Recorder/Monitor (PRM)
- Model 3140 ZOOM Wireless Transmitter
- Model 2869 ZOOMVIEW Software Application
- Model 6577 Accessory Telemetry Wand

You can use the PRM system to do the following:

- Interrogate the pulse generator
- Program the pulse generator to provide a variety of therapy options
- Access the pulse generator's diagnostic features
- Perform noninvasive diagnostic testing
- Access therapy history data
- Store a 12 second trace of the ECG/EGM display from any screen
- Access an interactive Demonstration Mode or Patient Data Mode without the presence of a pulse generator

- Print patient data including pulse generator therapy options and therapy history data
- Save patient data

You can program the pulse generator using two methods: automatically using Indications-Based Programming (IBP) or manually.

#### **RELATED INFORMATION**

Refer to the lead's instruction manual for implant information, general warnings and precautions, indications, contraindications, and technical specifications. Read this material carefully for implant procedure instructions specific to the chosen lead configurations.

Refer to the PRM system Operator's Manual or ZOOM Wireless Transmitter Reference Guide for specific information about the PRM or ZOOM Wireless Transmitter such as setup, maintenance, and handling.

Refer to the ImageReady MR Conditional Pacing System MRI Technical Guide for information about MRI scanning.

LATITUDE NXT is a remote monitoring system that provides pulse generator data for clinicians. These pulse generators are designed to be LATITUDE NXT enabled; availability varies by region.

LATITUDE NXT is available for the following devices: ACCOLADE, PROPONENT, ESSENTIO, FORMIO, VITALIO, INGENIO, and ADVANTIO.

- Physicians/Clinicians—LATITUDE NXT enables you to periodically monitor both patient and device status remotely and automatically. The LATITUDE NXT system provides patient data that can be used as part of the clinical evaluation of the patient.

- Patients—A key component of the system is the LATITUDE Communicator, an easy-to-use, in-home monitoring device. The Communicator automatically reads implanted device data from a compatible Boston Scientific pulse generator at times scheduled by the physician. The Communicator sends this data to the LATITUDE NXT secure server through a standard analog telephone line or over a cellular data network. The LATITUDE NXT server displays the patient data on the LATITUDE NXT Web site, which is readily accessible over the Internet to authorized physicians and clinicians.

Refer to the LATITUDE NXT Clinician Manual for more information.

#### **INTENDED AUDIENCE**

This literature is intended for use by professionals trained or experienced in device implant and/or follow-up procedures.

#### **INDICATIONS AND USAGE**

Boston Scientific pacemakers are indicated for treatment of the following conditions:

- Symptomatic paroxysmal or permanent second- or third-degree AV block
- Symptomatic bilateral bundle branch block
- Symptomatic paroxysmal or transient sinus node dysfunction with or without associated AV conduction disorders (i.e., sinus bradycardia, sinus arrest, sinoatrial [SA] block)
- Bradycardia-tachycardia syndrome, to prevent symptomatic bradycardia or some forms of symptomatic tachyarrhythmias
- Neurovascular (vaso-vagal) syndromes or hypersensitive carotid sinus syndromes

Adaptive-rate pacing is indicated for patients exhibiting chronotropic incompetence and who may benefit from increased pacing rates concurrent with increases in minute ventilation and/or level of physical activity.

Dual-chamber and atrial tracking modes are also indicated for patients who may benefit from maintenance of AV synchrony.

4

Boston Scientific Confidential. Unauthorized use is prohibited.

**LIT APPROVAL - INGENIO 1-2 MRI PTM US**



Dual chamber modes are specifically indicated for treatment of the following:

- Conduction disorders that require restoration of AV synchrony, including varying degrees of AV block
- VVI intolerance (i.e., pacemaker syndrome) in the presence of persistent sinus rhythm
- Low cardiac output or congestive heart failure secondary to bradycardia

#### **CONTRAINDICATIONS**

These Boston Scientific pacemakers are contraindicated in patients who have a separate implanted cardioverter defibrillator (ICD) with transvenous leads.

Use of certain pacing modes and/or features available in these Boston Scientific pacemakers is contraindicated for the following patients under the circumstances listed:

- Unipolar pacing or use of the MV Sensor with a Subcutaneous Implantable Cardioverter Defibrillator (S-ICD) because it may cause inappropriate therapy or inhibition of appropriate S-ICD therapy.
- Minute Ventilation in patients with both unipolar atrial and ventricular leads
- Single-chamber atrial pacing in patients with impaired AV nodal conduction
- Atrial tracking modes for patients with chronic refractory atrial tachyarrhythmias (atrial fibrillation or flutter), which might trigger ventricular pacing
- Dual-chamber and single-chamber atrial pacing in patients with chronic refractory atrial tachyarrhythmias
- Asynchronous pacing in the presence (or likelihood) of competition between paced and intrinsic rhythms

#### **WARNINGS**

##### **General**

- **Labeling knowledge.** Read this manual thoroughly before implantation to avoid damage to the pulse generator and/or lead. Such damage can result in patient injury or death.

- **For single patient use only.** Do not reuse, reprocess, or resterilize. Reuse, reprocessing, or resterilization may compromise the structural integrity of the device and/or lead to device failure which, in turn, may result in patient injury, illness, or death. Reuse, reprocessing, or resterilization may also create a risk of contamination of the device and/or cause patient infection or cross-infection, including, but not limited to, the transmission of infectious disease(s) from one patient to another. Contamination of the device may lead to injury, illness, or death of the patient.
- **Backup defibrillation protection.** Always have external defibrillation equipment available during implant and electrophysiologic testing. If not terminated in a timely fashion, an induced ventricular tachyarrhythmia can result in the patient's death.
- **Separate pulse generator.** Using multiple pulse generators could cause pulse generator interaction, resulting in patient injury or a lack of therapy delivery. Test each system individually and in combination to help prevent undesirable interactions ("Minimizing Pacemaker/S-ICD Interaction" on page 25).
- **Safety Core operation.** In response to applicable nonrecoverable or repeat fault conditions, the pulse generator will switch irreversibly to Safety Core operation. Safety Core pacing may be unipolar, which may interact with an ICD ("Minimizing Pacemaker/S-ICD Interaction" on page 25). Safety Core behavior is affected by MRI Protection Mode. Refer to "Magnetic Resonance Imaging (MRI)" on page 22.

#### Handling

- **Do not kink leads.** Do not kink, twist, or braid the lead with other leads as doing so could cause lead insulation abrasion damage or conductor damage.

#### Programming and Device Operations

- **Atrial tracking modes.** Do not use atrial tracking modes in patients with chronic refractory atrial tachyarrhythmias. Tracking of atrial arrhythmias could result in ventricular tachyarrhythmias.
- **Lead Safety Switch.** Lead Safety Switch should be programmed Off for patients with an ICD. Unipolar pacing due to Lead Safety Switch is contraindicated for patients with an ICD.

6

- **RAAT testing.** Unipolar pacing due to RAAT is contraindicated and should be programmed off for patients with an ICD. The RAAT feature performs automatic threshold testing in a unipolar pacing configuration.
- **Sensitivity settings and EMI.** If programmed to a fixed atrial Sensitivity value of 0.15 mV, or a fixed sensitivity value of 2.0 mV or less in a unipolar lead configuration in any chamber, the pulse generator may be more susceptible to electromagnetic interference. This increased susceptibility should be taken into consideration when determining the follow-up schedule for patients requiring such a setting.

#### **Post-Implant**

- **Protected environments.** Advise patients to seek medical guidance before entering environments that could adversely affect the operation of the active implantable medical device, including areas protected by a warning notice that prevents entry by patients who have a pulse generator.
- **Magnetic Resonance Imaging (MRI) exposure.** Unless all of the MRI Conditions of Use are met, MRI scanning of the patient does not meet MR Conditional requirements for the implanted system, and significant harm to or death of the patient and/or damage to the implanted system may result.

For potential adverse events applicable when the Conditions of Use are met or not met, refer to the MRI Technical Guide. For additional warnings, precautions, and Conditions of Use, refer to "Magnetic Resonance Imaging (MRI)" on page 22.

- **Diathermy.** Do not subject a patient with an implanted pulse generator and/or lead to diathermy since diathermy may cause fibrillation, burning of the myocardium, and irreversible damage to the pulse generator because of induced currents.

#### **PRECAUTIONS**

##### **Clinical Considerations**

- **STAT PACE.** STAT PACE will initiate unipolar pacing. Unipolar pacing due to STAT PACE may cause inappropriate therapy or inhibition of appropriate S-ICD therapy.

- **Pacemaker-mediated tachycardia (PMT).** Programming minimum PVARP less than retrograde V–A conduction may increase the likelihood of a PMT.
- **Automatic Capture.** Automatic Capture is intended for ventricular use only. Do not program Amplitude to Auto for single-chamber devices implanted in the atrium.
- **MV sensor modes.** The safety and efficacy of the MV sensor modes have not been clinically established in patients with abdominal implant sites.
- **MV sensor mode performance.** MV sensor performance may be adversely affected under transient conditions such as pneumothorax, pericardial effusion, or pleural effusion. Consider programming the MV sensor Off until these conditions are resolved.
- **Adaptive-rate modes.** Adaptive-rate modes based completely or in part on MV might be inappropriate for patients who can achieve respiratory cycles shorter than one second (greater than 60 breaths per minute). Higher respiration rates attenuate the impedance signal, which diminishes the MV rate response (i.e., the pacing rate will drop toward the programmed LRL).

Adaptive-rate modes based completely or in part on MV should not be used for patients with:

- An ICD
- Unipolar leads—for MV detection, a bipolar lead is required in either the atrium or ventricle
- A lead other than a bipolar transvenous lead—MV measurement has only been tested with a bipolar transvenous lead
- A mechanical ventilator—use of the ventilator might result in an inappropriate MV sensor-driven rate

#### **Sterilization and Storage**

- **If package is damaged.** The blister trays and contents are sterilized with ethylene oxide gas before final packaging. When the pulse generator and/or lead is received, it is sterile provided the container is intact. If the packaging is wet, punctured, opened, or otherwise damaged, return the pulse generator and/or lead to Boston Scientific.
- **If device is dropped.** Do not implant a device which has been dropped while outside of its intact shelf package. Do not implant a device which has been dropped from a height of more than 24 inches (61 cm) while within its intact shelf package. Sterility, integrity and/or function cannot be guaranteed under these conditions and the device should be returned to Boston Scientific for inspection.
- **Storage temperature and equilibration.** Recommended storage temperatures are 0°C–50°C (32°F–122°F). Allow the device to reach a proper temperature before using telemetry communication capabilities, programming or implanting the device because temperature extremes may affect initial device function.
- **Device storage.** Store the pulse generator in a clean area away from magnets, kits containing magnets, and sources of EMI to avoid device damage.
- **Use by date.** Implant the pulse generator and/or lead before or on the USE BY date on the package label because this date reflects a validated shelf life. For example, if the date is January 1, do not implant on or after January 2.

#### **Implantation**

- **Expected benefits.** Determine whether the expected device benefits provided by programmable options outweigh the possibility of more rapid battery depletion.
- **Evaluate patient for surgery.** There may be additional factors regarding the patient's overall health and medical condition that, while not related to device function or purpose, could render the patient a poor candidate for implantation of this system. Cardiac health advocacy groups may have published guidelines that may be helpful in conducting this evaluation.

- **Lead compatibility.** Prior to implantation, confirm the lead-to-pulse generator compatibility. Using incompatible leads and pulse generators can damage the connector and/or result in potential adverse consequences, such as undersensing of cardiac activity or failure to deliver necessary therapy.
- **Telemetry wand.** Make sure a sterile telemetry wand is available should loss of ZIP telemetry occur. Verify that the wand can easily be connected to the programmer and is within reach of the pulse generator.
- **Line-powered equipment.** Exercise extreme caution if testing leads using line-powered equipment because leakage current exceeding 10  $\mu$ A can induce ventricular fibrillation. Ensure that any line-powered equipment is within specifications.
- **Replacement device.** Implanting a replacement device in a subcutaneous pocket that previously housed a larger device may result in pocket air entrapment, migration, erosion, or insufficient grounding between the device and tissue. Irrigating the pocket with sterile saline solution decreases the possibility of pocket air entrapment and insufficient grounding. Suturing the device in place reduces the possibility of migration and erosion.
- **Do not bend the lead near the lead-header interface.** Insert the lead terminal straight into the lead port. Do not bend the lead near the lead-header interface. Improper insertion can cause insulation or connector damage.
- **Absence of a lead.** The absence of a lead or plug in a lead port may affect device performance. If a lead is not used, be sure to properly insert a plug in the unused port, and then tighten the setscrew onto the plug.
- **Dual chamber device without a functional RV lead.** If a dual-chamber device is programmed to AAI(R), ensure that a functional RV lead is present. In the absence of a functional RV lead, programming to AAI(R) may result in undersensing or oversensing.

10

Boston Scientific Confidential. Unauthorized use is prohibited.

LIT APPROVAL - INGENIO 1-2 MRI PTM US

Approved

1124977 A

- **Electrode connections.** Do not insert a lead into the pulse generator connector without taking the following precautions to ensure proper lead insertion:
  - Insert the torque wrench into the prelit depression of the seal plug before inserting the lead into the port, to release any trapped fluid or air.
  - Visually verify that the setscrew is sufficiently retracted to allow insertion. Use the torque wrench to loosen the setscrew if necessary.
  - Fully insert each lead into its lead port and then tighten the setscrew onto the terminal pin.
- **Do not suture directly over lead.** Do not suture directly over the lead body, as this may cause structural damage. Use the suture sleeve to secure the lead proximal to the venous entry site to prevent lead movement.
- **MV Sensor.** Do not program the MV sensor to On until after the pulse generator has been implanted and system integrity has been tested and verified.

#### **Device Programming**

- **Device communication.** Use only the designated PRM and software application to communicate with this pulse generator.
- **STAT PACE settings.** When a pulse generator is programmed to STAT PACE settings, it will continue to pace at the high-energy STAT PACE values if it is not reprogrammed. The use of STAT PACE parameters will likely decrease device longevity.

- **Pacing and sensing margins.** Consider lead maturation in your choice of Pacing Amplitude, pacing Pulse Width, and Sensitivity settings.
  - An acute Pacing Threshold greater than 1.5 V or a chronic Pacing Threshold greater than 3 V can result in loss of capture because thresholds may increase over time.
  - An R-Wave Amplitude less than 5 mV or a P-Wave Amplitude less than 2 mV can result in undersensing because the sensed amplitude may decrease after implantation.
  - Pacing Lead Impedance should be greater than the programmed Low Impedance Limit and less than 2000  $\Omega$  (or the programmed High Impedance Limit).
- **Lead impedance values and Lead Safety Switch.** If properly functioning leads with stable measured impedance values near the programmed impedance limits are used, consider programming Lead Safety Switch Off or changing the impedance limits to avoid undesirable switching to a Unipolar Lead Configuration.
- **Proper programming of the lead configuration.** If the Lead Configuration is programmed to Bipolar when a unipolar lead is implanted, pacing will not occur.
- **Programming for supraventricular tachyarrhythmias (SVTs).** Determine if the device and programmable options are appropriate for patients with SVTs because SVTs can initiate unwanted device therapy.
- **Adaptive-rate pacing.** Rate Adaptive Pacing should be used with care in patients who are unable to tolerate increased pacing rates.
- **Ventricular refractory periods (VRPs) in adaptive-rate pacing.** Adaptive-rate pacing is not limited by refractory periods. A long refractory period programmed in combination with a high MSR can result in asynchronous pacing during refractory periods since the combination can cause a very small sensing window or none at all. Use Dynamic AV Delay or Dynamic PVARP to optimize sensing windows. If you are programming a fixed AV Delay, consider the sensing outcomes.

12



- **MTR/MSR programming.** The pulse generator's MTR and MSR should be programmed to a rate lower than a concomitant S-ICD's lowest tachycardia detection zone.
- **Atrial oversensing.** Take care to ensure that artifacts from the ventricles are not present on the atrial channel, or atrial oversensing may result. If ventricular artifacts are present in the atrial channel, the atrial lead may need to be repositioned to minimize its interaction.
- **ATR entry count.** Exercise care when programming the Entry Count to low values in conjunction with a short ATR Duration. This combination allows mode switching with very few fast atrial beats. For example, if the Entry Count was programmed to 2 and the ATR Duration to 0, ATR mode switching could occur on 2 fast atrial intervals. In these instances, a short series of premature atrial events could cause the device to mode switch.
- **ATR exit count.** Exercise care when programming the Exit Count to low values. For example, if the Exit Count was programmed to 2, a few cycles of atrial undersensing could cause termination of mode switching.
- **Proper programming without an atrial lead.** If an atrial lead is not implanted (port is plugged instead), or an atrial lead is abandoned but remains connected to the header, device programming should be consistent with the number and type of leads actually in use.
- **Atrial sensing programmed to Off.** When atrial sensing is programmed to Off in a DDI(R) or DDD(R) mode, any atrial pacing that occurs will be asynchronous. Additionally, features that require atrial sensing may not function as expected.
- **High atrial rates.** Sensing high atrial rates may impact device longevity. Therefore, the Atrial Sense lead configuration will be seeded to Off when programming from an atrial sensing mode to a non-atrial sensing mode.
- **Cross-chamber artifacts.** Sensitivity adjustments associated with Smart Blanking may not be sufficient to inhibit detection of cross-chamber artifacts if the cross-chamber artifacts are too large. Consider other factors that impact the size/amplitude of cross-chamber artifacts including lead-placement, pacing output, and programmed Sensitivity settings.

- **Sensor signal artifacts.** If MV Sensor signal artifacts are observed on EGMs, and the leads are otherwise shown to be performing appropriately, consider programming the sensor to Off to prevent oversensing.
- **Single pass VDD leads.** When a single pass VDD lead is used with a dual-chamber device, the atrial electrodes may not be in contact with the atrial wall. In this case, the measured depolarization signal has a relatively low Amplitude and could require a more sensitive setting.
- **MV Recalibration.** To obtain an accurate MV baseline, the MV sensor will be calibrated automatically or can be calibrated manually. A new, manual calibration should be performed if the pulse generator is removed from the pocket following implant, such as during a lead repositioning procedure, or in cases where the MV baseline may have been affected by factors such as lead maturation, air entrapment in the pocket, pulse generator motion due to inadequate suturing, external defibrillation or cardioversion, or other patient complications (e.g., pneumothorax).
- **Sensing adjustment.** Following any Sensitivity parameter adjustment or any modification of the sensing lead, always verify appropriate sensing. Programming Sensitivity to the highest value (lowest sensitivity) may result in undersensing of cardiac activity. Likewise, programming to the lowest value (highest sensitivity) may result in oversensing of non-cardiac signals.
- **Sensitivity in unipolar lead configuration.** The amplitude and prevalence of myopotential noise is increased in unipolar lead configurations, as compared to bipolar lead configurations. For patients with a unipolar lead configuration and myopotential oversensing during activity involving the pectoral muscles, the programming of Fixed Sensitivity is recommended.

- **Use of Patient Triggered Monitor.** Use care when using Patient Triggered Monitor, because the following conditions will exist while it is enabled:
  - All other magnet features, including asynchronous pacing, are disabled. The Magnet feature will not indicate magnet position.
  - Device longevity is impacted. To help reduce the longevity impact, PTM only allows storage of one episode, and PTM is automatically disabled after 60 days if data storage was never triggered.
  - Once the EGM is stored (or 60 days elapses), PTM is disabled and the device Magnet Response automatically will be set to Pace Async. However, if a magnet is used, the pulse generator will not revert to asynchronous operation until the magnet is removed for 3 seconds and placed on the device again.

#### **Environmental and Medical Therapy Hazards**

- **Avoid electromagnetic interference (EMI).** Advise patients to avoid sources of EMI. The pulse generator may inhibit pacing due to oversensing, or may switch to asynchronous pacing at the programmed pacing rate or at the magnet rate in the presence of EMI.

Moving away from the source of the EMI or turning off the source usually allows the pulse generator to return to normal operation.

Examples of potential EMI sources are:

- Electrical power sources, arc welding or resistance welding equipment, and robotic jacks
- High voltage power distribution lines
- Electrical smelting furnaces
- Large RF transmitters such as radar
- Radio transmitters, including those used to control toys
- Electronic surveillance (antitheft) devices
- An alternator on a car that is running
- Medical treatments and diagnostic tests in which an electrical current is passed through the body, such as TENS, electrocautery, electrolysis/thermolysis, electrodiagnostic testing, electromyography, or nerve conduction studies
- Any externally applied device that uses an automatic lead detection alarm system (e.g., an EKG machine)

#### Hospital and Medical Environments

- **Mechanical ventilators.** Program the MV Sensor to Off during mechanical ventilation. Otherwise, the following may occur:
  - Inappropriate MV sensor-driven rate
  - Misleading respiration-based trending
- **Conducted electrical current.** Any medical equipment, treatment, therapy, or diagnostic test that introduces electrical current into the patient has the potential to interfere with pulse generator function.
  - External patient monitors (e.g., respiratory monitors, surface ECG monitors, hemodynamic monitors) may interfere with the pulse generator's impedance-based diagnostics (e.g., Respiratory Rate trend). This interference may also result in accelerated pacing, possibly up to the maximum sensor-driven rate, when MV is programmed to On. To resolve suspected interactions with the MV sensor, deactivate the sensor either by programming it to Off (no MV rate driving or MV sensor-based trending will occur), or Passive (no MV rate driving will occur). Alternatively, program the Brady Mode to a non-rate responsive mode (no MV rate driving will occur). If a PRM is not available and the pulse generator is pacing at the sensor-driven rate, apply a magnet to the pulse generator to initiate temporary asynchronous, non-rate responsive pacing.
  - Medical therapies, treatments, and diagnostic tests that use conducted electrical current (e.g., TENS, electrocautery, electrolysis/thermolysis, electrodiagnostic testing, electromyography, or nerve conduction studies) may interfere with or damage the pulse generator. Program the device to Electrocautery Protection Mode prior to the treatment, and monitor device performance during the treatment. After the treatment, verify pulse generator function ("Post-Therapy Pulse Generator Follow Up" on page 21).
- **Internal defibrillation.** Do not use internal defibrillation paddles or catheters unless the pulse generator is disconnected from the leads because the leads may shunt energy. This could result in injury to the patient and damage to the implanted system.

- **External defibrillation.** It can take up to 15 seconds for sensing to recover after an external shock is delivered. In non-emergency situations, for pacemaker dependent patients, consider programming the pulse generator to an asynchronous pacing mode and programming the MV sensor to Off prior to performing external cardioversion or defibrillation.

External defibrillation or cardioversion can damage the pulse generator. To help prevent damage to the pulse generator, consider the following:

- Avoid placing a pad (or paddle) directly over the pulse generator. Position the pads (or paddles) as far from the pulse generator as possible.
- Position the pads (or paddles) in a posterior-anterior orientation when the device is implanted in the right pectoral region or an anterior-apex orientation when the device is implanted in the left pectoral region.
- Set energy output of external defibrillation equipment as low as clinically acceptable.

Following external cardioversion or defibrillation, verify pulse generator function ("Post-Therapy Pulse Generator Follow Up" on page 21).

- **Lithotripsy.** Extracorporeal shock wave lithotripsy (ESWL) may cause electromagnetic interference with or damage to the pulse generator. If ESWL is medically necessary, consider the following to minimize the potential for encountering interaction:
  - Focus the ESWL beam at least 15 cm (6 in) away from the pulse generator.
  - Depending on the pacing needs of the patient, program the Brady Mode to a non-rate-responsive VVI or VOO mode.
- **Ultrasound energy.** Therapeutic ultrasound (e.g., lithotripsy) energy may damage the pulse generator. If therapeutic ultrasound energy must be used, avoid focusing near the pulse generator site. Diagnostic ultrasound (e.g., echocardiography) is not known to be harmful to the pulse generator.

- **Electrical interference.** Electrical interference or "noise" from devices such as electrocautery and monitoring equipment may interfere with establishing or maintaining telemetry for interrogating or programming the device. In the presence of such interference, move the programmer away from electrical devices, and ensure that the wand cord and cables are not crossing one another. If telemetry is cancelled as a result of interference, the device should be re-interrogated prior to evaluating information from pulse generator memory.
- **Radio frequency (RF) interference.** RF signals from devices that operate at frequencies near that of the pulse generator may interrupt ZIP telemetry while interrogating or programming the pulse generator. This RF interference can be reduced by increasing the distance between the interfering device and the PRM and pulse generator. Examples of devices that may cause interference in the 916.5 MHz frequency band include:
  - Cordless phone handsets or base stations
  - Certain patient monitoring systems
- **Central line guidewire insertion.** Use caution when inserting guidewires for placement of other types of central venous catheter systems such as PIC lines or Hickman catheters in locations where pulse generator leads may be encountered. Insertion of such guidewires into veins containing leads could result in the leads being damaged or dislodged.

#### **Home and Occupational Environments**

- **Home appliances.** Home appliances that are in good working order and properly grounded do not usually produce enough EMI to interfere with pulse generator operation. There have been reports of pulse generator disturbances caused by electric hand tools or electric razors used directly over the pulse generator implant site.

- **Magnetic fields.** Advise patients that extended exposure to strong (greater than 10 gauss or 1 mTesla) magnetic fields may trigger the magnet feature. Examples of magnetic sources include:
  - Industrial transformers and motors
  - MRI scanners

*NOTE: The magnet feature is disabled when the device is in MRI Protection Mode. Refer to "Magnetic Resonance Imaging (MRI)" on page 22 and the MRI Technical Guide for more information.*

  - Large stereo speakers
  - Telephone receivers if held within 1.27 cm (0.5 inches) of the pulse generator
  - Magnetic wands such as those used for airport security and in the Bingo game
- **Electronic Article Surveillance (EAS) and Security Systems.** Advise patients to avoid lingering near or leaning against anti-theft and security gates or tag readers that include radio frequency identification (RFID) equipment. These systems may be found at the entrances and exits of stores, in public libraries, and in point-of-entry access control systems. These systems are unlikely to affect cardiac device function when patients walk through them at a normal pace. If the patient is near an electronic anti-theft, security, or entry control system and experiences symptoms, they should promptly move away from nearby equipment and inform their doctor.
- **Cellular phones.** Advise patients to hold cellular phones to the ear opposite the side of the implanted device. Patients should not carry a cellular phone that is turned on in a breast pocket or on a belt within 15 cm (6 inches) of the implanted device since some cellular phones may cause the pulse generator to deliver inappropriate therapy or inhibit appropriate therapy.

**Follow-up Testing**

- **Pacing threshold testing.** If the patient's condition or drug regimen has changed or device parameters have been reprogrammed, consider performing a pacing threshold test to confirm adequate margins for pace capture.

20



- **Follow-up considerations for patients leaving the country.** Pulse generator follow-up considerations should be made in advance for patients who plan to travel or relocate post-implant to a country other than the country in which their device was implanted. Regulatory approval status for devices and associated programmer software configurations varies by country; certain countries may not have approval or capability to follow specific products.

Contact Boston Scientific, using the information on the back cover, for help in determining feasibility of device follow-up in the patient's destination country.

#### **Explant and Disposal**

- **Incineration.** Be sure that the pulse generator is removed before cremation. Cremation and incineration temperatures might cause the pulse generator to explode.
  - **Device handling.** Before explanting, cleaning, or shipping the device, complete the following actions to prevent overwriting of important therapy history data:
    - Program the pulse generator Brady Mode to Off
    - Program Ventricular Tachy EGM Storage to Off
- Clean and disinfect the device using standard biohazard handling techniques.

#### **SUPPLEMENTAL PRECAUTIONARY INFORMATION**

##### **Post-Therapy Pulse Generator Follow Up**

Following any surgery or medical procedure with the potential to affect pulse generator function, you should perform a thorough follow-up, which may include the following:

- Interrogating the pulse generator with a programmer
- Reviewing clinical events and fault codes
- Reviewing the Arrhythmia Logbook, including stored electrograms (EGMs)

- Reviewing real-time EGMs
- Testing the leads (threshold, amplitude, and impedance)
- Reviewing MV sensor-based diagnostics, MV sensor performance, and performing a manual MV sensor calibration if desired
- Verifying battery status
- Programming any permanent brady parameter to a new value and then reprogramming it back to the desired value
- Saving all patient data
- Verifying the appropriate final programming prior to allowing the patient to leave the clinic

**Magnetic Resonance Imaging (MRI)**

The following Warnings and Precautions, and Conditions of Use are applicable to MRI scanning of patients implanted with an ImageReady MR Conditional Pacing System. Refer to the MRI Technical Guide at [www.bostonscientific.com/ifu](http://www.bostonscientific.com/ifu) for a comprehensive list of Warnings and Precautions, and Conditions of Use that are applicable to MRI scanning of patients implanted with an ImageReady MR Conditional Pacing System.

**MR Conditional Pacing System Warnings and Precautions**

**WARNING:** Unless all of the MRI Conditions of Use are met, MRI scanning of the patient does not meet MR Conditional requirements for the implanted system, and significant harm to or death of the patient and/or damage to the implanted system may result.

For potential adverse events applicable when the Conditions of Use are met or not met, refer to the MRI Technical Guide. For additional warnings, precautions, and Conditions of Use, refer to "Magnetic Resonance Imaging (MRI)" on page 22.

**WARNING:** The Programmer/Recorder/Monitor (PRM) is MR Unsafe and must remain outside the MRI site Zone III (and higher) as defined by the American College of Radiology Guidance Document for Safe MR Practices<sup>2</sup>. Under no circumstances should the PRM be brought into the MRI scanner room, the control room, or the MRI site Zone III or IV areas.

**WARNING:** Implant of the system cannot be performed in an MRI site Zone III (and higher) as defined by the American College of Radiology Guidance Document for Safe MR Practices<sup>3</sup>. Some of the accessories packaged with pulse generators and leads, including the torque wrench and stylet wires, are not MR Conditional and should not be brought into the MRI scanner room, the control room, or the MRI site Zone III or IV areas.

**WARNING:** Use caution when programming the MRI Protection Mode pacing amplitude for pacing-dependent patients who have high pacing thresholds (> 2.0 V). Programming pacing amplitude below 5.0 V is provided as an option in case of extracardiac stimulation (for example, diaphragmatic stimulation for RV pacing). If pacing amplitude is programmed below 5.0 V, an appropriate safety margin (2X the pacing threshold + 1.0 V) should be maintained. An inadequate safety margin may result in loss of capture.

**CAUTION:** Consider an individual patient's ability to tolerate the pacing parameters required for MR Conditional scanning in conjunction with the physical conditions required during a scan (for example, prolonged time in a supine position).

2. Kanal E, et al., American Journal of Roentgenology 188:1447-74, 2007.
3. Kanal E, et al., American Journal of Roentgenology 188:1447-74, 2007.

**CAUTION:** Consider that the following backup pacing parameters will be different from normal Safety Mode operation if the pulse generator was in MRI Protection Mode (with Pacing Mode set to a value other than Off) when it reverted to Safety Mode:

- Brady Mode—VOO
- RV Lead Configuration—Bipolar
- RV Refractory Period (RVRP)—not applicable due to asynchronous pacing
- RV Sensitivity—not applicable due to asynchronous pacing
- Noise Response—not applicable due to asynchronous pacing

**NOTE:** *Other implanted devices or patient conditions may still cause a patient to be ineligible for an MRI scan, independent of the status of the patient's ImageReady MR Conditional Pacing System.*

**MRI Conditions of Use**

The following Conditions of Use must be met in order for a patient with an ImageReady Pacing System to undergo an MRI scan. Adherence to the Conditions of Use must be verified prior to each scan to ensure that the most up to date information has been used to assess the patient's eligibility and readiness for an MR Conditional scan. Refer to the MRI Technical Guide at [www.bostonscientific.com/ifu](http://www.bostonscientific.com/ifu) for a comprehensive list of Warnings and Precautions, and Conditions of Use that are applicable to MRI scanning of patients implanted with an ImageReady MR Conditional Pacing System.

Cardiology

1. Patient is implanted with an ImageReady MR Conditional Pacing System
2. Bipolar pacing operation or pacing off
3. Pulse generator implant location restricted to left or right pectoral region
4. At least six (6) weeks have elapsed since implantation and/or any lead revision or surgical modification of the MR Conditional Pacing System

24

5. No cardiac-related implanted devices, components, or accessories present other than an ImageReady MR Conditional Pacing System, refer to the MRI Technical Guide
6. Pacing threshold  $\leq 2.0$  V in pace-dependent patients
7. No abandoned leads or pulse generators
8. No evidence of a fractured lead or compromised pulse generator-lead system integrity

#### **Minimizing Pacemaker/S-ICD Interaction**

These pulse generators are compatible for use with a Subcutaneous Implantable Cardioverter Defibrillator (S-ICD) when implanted with bipolar leads and programmed to a bipolar pacing configuration.

A pacemaker can interact with an S-ICD in the following ways:

- If during a tachyarrhythmia the pacemaker is not inhibited and the pacing pulses are detected by the rate-sensing circuit of the S-ICD, the S-ICD could interpret the pacing pulses as a normal rhythm. The S-ICD would not detect the arrhythmia and therefore would not deliver therapy.
- Pacemaker failure to sense or to capture could result in two independent signals (intrinsic and pacing pulses) to the S-ICD. This could cause the S-ICD's rate measurement to be faster than the actual heart rate. As a result, the S-ICD could deliver unnecessary therapy.
- If the S-ICD counts both the pacing pulses and the resultant ventricular depolarizations, the S-ICD's rate measurement would be faster than the actual heart rate. This could result in unnecessary S-ICD therapy.

In Safety Mode, these pulse generators use a unipolar pacing and sensing configuration. Safety Mode is compatible for use with an S-ICD because the configured parameters mitigate the potential pacemaker and S-ICD interactions as follows:

- Sensing is AGC at 0.25 mV. The AGC sensing is able to effectively sense an intrinsic rhythm faster than the Safety Mode LRL of 72.5 bpm. As a result, pacing is inhibited and does not interfere with S-ICD tachyarrhythmia detection.

- When pacing is necessary, the elevated output of 5.0 V and 1.0 ms reduces the risk of not capturing.
- If double detection of the pace pulse and the resulting depolarization were to occur, it would not result in unnecessary S-ICD therapy provided the S-ICD tachy threshold is more than twice the Safety Mode LRL (145 ppm).

To help minimize device-device interaction of a bipolar pacemaker when an S-ICD is already implanted, follow these precautionary measures:

- Use bipolar pacing leads with close electrode spacing in both chambers. Significant spacing between electrodes may increase the likelihood that the S-ICD will detect the pacing pulses.
- Consider programming the pacemaker to (1) the lowest Amplitude allowable for safe capture in the chronic state, (2) the maximum Sensitivity (the lowest programmable level) while maintaining an adequate safety margin, and (3) the minimum cardiac rate acceptable for the patient.

In addition to the above steps, perform the following testing to assess device-device interaction:

- Use the S-ICD features, such as markers, real-time electrograms (EGMs), and/or beeping tones, to help evaluate potential for pacemaker interaction due to oversensing by the S-ICD.

**NOTE:** *If a single chamber pacemaker is implanted with an atrial lead, perform testing in both unipolar and bipolar configurations.*

- Ventricular fibrillation and all of the patient's ventricular tachycardias should be induced while the S-ICD is activated and the pacemaker is programmed to an asynchronous mode at maximum Amplitude and Pulse Width. This should provide the greatest opportunity for inhibition of arrhythmia detection due to detection of pacemaker pacing pulses. The pacemaker leads might have to be repositioned to eliminate detection of the pacing pulses by the S-ICD.

Temporarily deactivate the patient's S-ICD when (1) evaluating pacing and sensing thresholds, (2) when using an external temporary pacemaker during implant, and (3) when reprogramming an implanted pacemaker.

Following any S-ICD discharge, reinterrogate the pacemaker to ensure that the S-ICD shock did not damage the pacemaker.

If implanting an S-ICD in a patient who has a pacemaker already implanted, refer to the S-ICD manual for implantation considerations.

Refer to the Warnings section for additional information regarding pacemaker and S-ICD interactions.

#### **Transcutaneous Electrical Nerve Stimulation (TENS)**

**CAUTION:** TENS involves passing electrical current through the body, and may interfere with pulse generator function. If TENS is medically necessary, evaluate the TENS therapy settings for compatibility with the pulse generator. The following guidelines may reduce the likelihood of interaction:

- Place the TENS electrodes as close together and as far away from the pulse generator and leads as possible.
- Use the lowest clinically-appropriate TENS energy output.
- Consider cardiac monitoring during TENS use, especially for pacemaker-dependent patients.

Additional steps can be taken to help reduce interference during in-clinic use of TENS:

- If interference is suspected during in-clinic use, turn off the TENS unit.
- If pacing inhibition is observed, use a magnet to pace asynchronously.
- Do not change TENS settings until you have verified that the new settings do not interfere with pulse generator function.

If TENS is medically necessary outside the clinical setting (at-home use), provide patients with the following instructions:

- Do not change the TENS settings or electrode positions unless instructed to do so.
- End each TENS session by turning off the unit before removing the electrodes.

- If the patient experiences symptoms of lightheadedness, dizziness, or loss of consciousness during TENS use, they should turn off the TENS unit and contact their physician.

Follow these steps to use the PRM to evaluate pulse generator function during TENS use:

1. Observe real-time EGMs at prescribed TENS output settings, noting when appropriate sensing or interference occurs.

**NOTE:** *Patient triggered monitoring may be used as an additional method to confirm device function during TENS use.*

2. When finished, turn off the TENS unit.

You should also perform a thorough follow-up evaluation of the pulse generator following TENS, to ensure that device function has not been compromised ("Post-Therapy Pulse Generator Follow Up" on page 21).

For additional information, contact Boston Scientific using the information on the back cover.

#### **Electrocautery and Radio Frequency (RF) Ablation**

**CAUTION:** Electrocautery and RF ablation may induce ventricular arrhythmias and/or fibrillation, and may cause asynchronous pacing, inhibition of pacing, and/or a reduction in pulse generator pacing output possibly leading to loss of capture. RF ablation may also cause ventricular pacing up to the MTR and/or changes in pacing thresholds. Additionally, exercise caution when performing any other type of cardiac ablation procedure in patients with implanted devices.

If electrocautery or RF ablation is medically necessary, observe the following to minimize risk to the patient and device:

- Depending on the pacing needs of the patient, enable the Electrocautery Protection Mode, program to an asynchronous pacing mode, or use a magnet to switch to asynchronous pacing. An option for patients with intrinsic rhythm is to program the Brady Mode to VVI at a rate below the intrinsic rate to avoid competitive pacing.



- Have temporary pacing and external defibrillation equipment available.
- Avoid direct contact between the electrocautery equipment or ablation catheters and the pulse generator and leads. RF ablation close to the lead electrode may damage the lead-tissue interface.
- Keep the path of the electrical current as far away as possible from the pulse generator and leads.
- If RF ablation and/or electrocautery is performed on tissue near the device or leads, monitor pre- and post-measurements for sensing and pacing thresholds and impedances to determine the integrity and stability of the system.
- For electrocautery, use a bipolar electrocautery system where possible and use short, intermittent, and irregular bursts at the lowest feasible energy levels.
- RF ablation equipment may cause telemetry interference between the pulse generator and PRM. If device programming changes are necessary during an RF ablation procedure, turn off the RF ablation equipment before interrogation.

When the procedure is finished, cancel the Electrocautery Protection Mode in order to reactivate the previously programmed therapy modes.

### **Ionizing Radiation**

**CAUTION:** It is not possible to specify a safe radiation dosage or guarantee proper pulse generator function following exposure to ionizing radiation. Multiple factors collectively determine the impact of radiation therapy on an implanted pulse generator, including proximity of the pulse generator to the radiation beam, type and energy level of the radiation beam, dose rate, total dose delivered over the life of the pulse generator, and shielding of the pulse generator. The impact of ionizing radiation will also vary from one pulse generator to another and may range from no changes in function to a loss of pacing.

Sources of ionizing radiation vary significantly in their potential impact on an implanted pulse generator. Several therapeutic radiation sources are capable of interfering with or damaging an implanted pulse generator, including those used for the treatment of cancer, such as radioactive cobalt, linear accelerators, radioactive seeds, and betatrons.

Prior to a course of therapeutic radiation treatment, the patient's radiation oncologist and cardiologist or electrophysiologist should consider all patient management options, including increased follow-up and device replacement. Other considerations include:

- Maximizing shielding of the pulse generator within the treatment field
- Determining the appropriate level of patient monitoring during treatment

Evaluate pulse generator operation during and following the course of radiation treatment to exercise as much device functionality as possible ("Post-Therapy Pulse Generator Follow Up" on page 21). The extent, timing, and frequency of this evaluation relative to the radiation therapy regimen are dependent upon current patient health, and therefore should be determined by the attending cardiologist or electrophysiologist.

Many pulse generator diagnostics are performed automatically once per hour, so pulse generator evaluation should not be concluded until pulse generator diagnostics have been updated and reviewed (at least one hour after radiation exposure). The effects of radiation exposure on the implanted pulse generator may remain undetected until some time following exposure. For this reason, continue to monitor pulse generator function closely and use caution when programming a feature in the weeks or months following radiation therapy.

**Elevated Pressures**

The International Standards Organization (ISO) has not approved a standardized pressure test for implantable pulse generators that experience hyperbaric oxygen therapy (HBOT) or SCUBA diving. However, Boston Scientific developed a test protocol to evaluate device performance upon exposure to elevated atmospheric pressures. The following summary of pressure testing should not be viewed as and is not an endorsement of HBOT or SCUBA diving.

**CAUTION:** Elevated pressures due to HBOT or SCUBA diving may damage the pulse generator. During laboratory testing, all pulse generators in the test sample functioned as designed when exposed to more than 1000 cycles at a pressure up to 5.0 ATA. Laboratory testing did not characterize the impact of elevated pressure on pulse generator performance or physiological response while implanted in a human body.

Pressure for each test cycle began at ambient/room pressure, increased to a high pressure level, and then returned to ambient pressure. Although dwell time (the amount of time under elevated pressure) may have an impact on human physiology, testing indicated it did not impact pulse generator performance. Pressure value equivalencies are provided below (Table 1 on page 31).

**Table 1. Pressure Value Equivalencies**

Pressure value equivalencies	
Atmospheres Absolute	5.0 ATA
Sea water depth <sup>a</sup>	40 m (130 ft)
Pressure, absolute	72.8 psia
Pressure, gauge <sup>b</sup>	58.1 psig

**Table 1. Pressure Value Equivalencies** (continued)

Pressure value equivalencies	
Bar	5.0
kPa Absolute	500

- a. All pressures were derived assuming sea water density of 1030 kg/m<sup>3</sup>.  
b. Pressure as read on a gauge or dial (psia = psig + 14.7 psi).

Prior to SCUBA diving or starting an HBOT program, the patient's attending cardiologist or electrophysiologist should be consulted to fully understand the potential consequences relative to the patient's specific health condition. A Dive Medicine Specialist may also be consulted prior to SCUBA diving.

More frequent device follow-up may be warranted in conjunction with HBOT or SCUBA diving. Evaluate pulse generator operation following high pressure exposure ("Post-Therapy Pulse Generator Follow Up" on page 21). The extent, timing, and frequency of this evaluation relative to the high pressure exposure are dependent upon current patient health, and should be determined by the attending cardiologist or electrophysiologist.

If you have additional questions, or would like more detail regarding the test protocol or test results specific to HBOT or SCUBA diving, contact Boston Scientific using the information on the back cover.

**POTENTIAL ADVERSE EVENTS**

Based on the literature and on pulse generator and/or lead implant experience, the following alphabetical list includes the possible adverse events associated with implantation of products described in this literature:

- Air embolism
- Allergic reaction
- Bleeding
- Bradycardia

- Cardiac tamponade
- Chronic nerve damage
- Component failure
- Conductor coil fracture
- Death
- Elevated thresholds
- Erosion
- Excessive fibrotic tissue growth
- Extracardiac stimulation (muscle/nerve stimulation)
- Fluid accumulation
- Foreign body rejection phenomena
- Formation of hematomas or seromas
- Heart block
- Heart failure following chronic RV apical pacing
- Inability to pace
- Inappropriate pacing
- Incisional pain
- Incomplete lead connection with pulse generator
- Infection including endocarditis
- Lead dislodgment
- Lead fracture
- Lead insulation breakage or abrasion
- Lead perforation

- Lead tip deformation and/or breakage
- Local tissue reaction
- Loss of capture
- Myocardial infarction (MI)
- Myocardial necrosis
- Myocardial trauma (e.g., tissue damage, valve damage)
- Myopotential sensing
- Oversensing/undersensing
- Pacemaker-mediated tachycardia (PMT) (Applies to dual-chamber devices only.)
- Pericardial rub, effusion
- Pneumothorax
- Pulse generator migration
- Shunting current during defibrillation with internal or external paddles
- Syncope
- Tachyarrhythmias, which include acceleration of arrhythmias and early, recurrent atrial fibrillation
- Thrombosis/thromboemboli
- Valve damage
- Vasovagal response
- Venous occlusion
- Venous trauma (e.g., perforation, dissection, erosion)
- Worsening heart failure

For a list of potential adverse events associated with MRI scanning, refer to the MRI Technical Guide.

Patients may develop psychological intolerance to a pulse generator system and may experience the following:

34

- Dependency
- Depression
- Fear of premature battery depletion
- Fear of device malfunction

**MECHANICAL SPECIFICATIONS**

The following mechanical specifications and material specifications apply to ACCOLADE, PROPONENT, ESSENTIO, and ALTRUA 2 devices.

**Table 2. Mechanical Specifications - All Pacemakers**

	SR	DR	DR EL
<b>Case Electrode Surface Area (cm<sup>2</sup>)</b>	29.10	28.92	35.05
<b>Usable Battery Capacity (Ah)</b>	1.0	1.0	1.6
<b>Residual Usable Battery Capacity at Explant (Ah)</b>	0.07	0.09	0.09

Mechanical specifications specific to each model are listed below.

**Table 3. Mechanical Specifications - ACCOLADE Pacemakers**

Model	Dimensions W x H x D (cm)	Mass (g)	Volume (cm <sup>3</sup> )	Connector Type
L300	4.45 x 4.81 x 0.75	23.6	13.2	RA/RV: IS-1

**Table 3. Mechanical Specifications - ACCOLADE Pacemakers (continued)**

Model	Dimensions W x H x D (cm)	Mass (g)	Volume (cm <sup>3</sup> )	Connector Type
L301	4.45 x 5.02 x 0.75	24.8	13.7	RA: IS-1; RV: IS-1
<b>MRI Model</b>				
L310	4.45 x 4.81 x 0.75	23.6	13.2	RA/RV: IS-1
L311	4.45 x 5.02 x 0.75	24.8	13.7	RA: IS-1; RV: IS-1

**Table 4. Mechanical Specifications - ACCOLADE EL Pacemakers**

Model	Dimensions W x H x D (cm)	Mass (g)	Volume (cm <sup>3</sup> )	Connector Type
L321	4.45 x 5.88 x 0.75	29.1	15.8	RA: IS-1; RV: IS-1
<b>MRI Model</b>				
L331	4.45 x 5.88 x 0.75	29.2	15.8	RA: IS-1; RV: IS-1

**Table 5. Mechanical Specifications - PROPONENT Pacemakers**

Model	Dimensions W x H x D (cm)	Mass (g)	Volume (cm <sup>3</sup> )	Connector Type
L200	4.45 x 4.81 x 0.75	23.6	13.2	RA/RV: IS-1



**Table 5. Mechanical Specifications - PROPONENT Pacemakers (continued)**

Model	Dimensions W x H x D (cm)	Mass (g)	Volume (cm <sup>3</sup> )	Connector Type
L201	4.45 x 5.02 x 0.75	24.8	13.7	RA: IS-1; RV: IS-1
<b>MRI Model</b>				
L210	4.45 x 4.81 x 0.75	23.6	13.2	RA/RV: IS-1
L211	4.45 x 5.02 x 0.75	24.8	13.7	RA: IS-1; RV: IS-1

**Table 6. Mechanical Specifications - PROPONENT EL Pacemakers**

Model	Dimensions W x H x D (cm)	Mass (g)	Volume (cm <sup>3</sup> )	Connector Type
L221	4.45 x 5.88 x 0.75	29.1	15.8	RA: IS-1; RV: IS-1
<b>MRI Model</b>				
L231	4.45 x 5.88 x 0.75	29.2	15.8	RA: IS-1; RV: IS-1

**Table 7. Mechanical Specifications - ESSENTIO Pacemakers**

Model	Dimensions W x H x D (cm)	Mass (g)	Volume (cm <sup>3</sup> )	Connector Type
L100	4.45 x 4.81 x 0.75	23.6	13.2	RA/RV: IS-1

37

**Table 7. Mechanical Specifications - ESSENTIO Pacemakers (continued)**

Model	Dimensions W x H x D (cm)	Mass (g)	Volume (cm <sup>3</sup> )	Connector Type
L101	4.45 x 5.02 x 0.75	24.8	13.7	RA: IS-1; RV: IS-1
<b>MRI Model</b>				
L110	4.45 x 4.81 x 0.75	23.6	13.2	RA/RV: IS-1
L111	4.45 x 5.02 x 0.75	24.8	13.7	RA: IS-1; RV: IS-1

**Table 8. Mechanical Specifications - ESSENTIO EL Pacemakers**

Model	Dimensions W x H x D (cm)	Mass (g)	Volume (cm <sup>3</sup> )	Connector Type
L121	4.45 x 5.88 x 0.75	29.1	15.8	RA: IS-1; RV: IS-1
<b>MRI Model</b>				
L131	4.45 x 5.88 x 0.75	29.2	15.8	RA: IS-1; RV: IS-1

**Table 9. Mechanical Specifications - ALTRUA 2 Pacemakers**

Model	Dimensions W x H x D (cm)	Mass (g)	Volume (cm <sup>3</sup> )	Connector Type
S701	4.45 x 4.81 x 0.75	23.6	13.2	RA/RV: IS-1
S702	4.45 x 5.02 x 0.75	24.8	13.7	RA: IS-1; RV: IS-1

**Table 10. Mechanical Specifications - ALTRUA 2 EL Pacemakers**

Model	Dimensions W x H x D (cm)	Mass (g)	Volume (cm <sup>3</sup> )	Connector Type
S722	4.45 x 5.88 x 0.75	29.1	15.8	RA: IS-1; RV: IS-1

ACCOLADE, PROPONENT, and ESSENTIO devices include ZIP telemetry operating with a transmit frequency of 402 to 405 MHz.

Material specifications are shown below:

- Case: hermetically sealed titanium
- Header: implantation-grade polymer
- Power Supply (ACCOLADE, PROPONENT, ESSENTIO, and ALTRUA 2) SR and DR models: lithium-carbon monofluoride cell; Boston Scientific; 402290
- Power Supply (ACCOLADE, PROPONENT, ESSENTIO, and ALTRUA 2) DR EL models: lithium-carbon monofluoride cell; Boston Scientific; 402294

**The following mechanical specifications and material specifications apply to FORMIO, VITALIO, INGENIO, and ADVANTIO devices.**

**Table 11. Mechanical Specifications - All Pacemakers**

	SR	DR	DR EL
<b>Case Electrode Surface Area (cm<sup>2</sup>)</b>	29.78	29.78	35.98
<b>Usable Battery Capacity (Ah)</b>	1.05	1.05	1.47
<b>Residual Usable Battery Capacity at Explant (Ah)</b>	0.06	0.08	0.08

Mechanical specifications specific to each model are listed below.

**Table 12. Mechanical Specifications - FORMIO Pacemakers**

<b>Model</b>	<b>Dimensions W x H x D (cm)</b>	<b>Mass (g)</b>	<b>Volume (cm<sup>3</sup>)</b>	<b>Connector Type</b>
K278	4.45 x 4.70 x 0.75	24.5	12.0	RA: IS-1; RV: IS-1
<b>MRI Model</b>				
K279	4.45 x 4.70 x 0.75	24.5	12.0	RA: IS-1; RV: IS-1

**Table 13. Mechanical Specifications - VITALIO Pacemakers**

<b>Model</b>	<b>Dimensions W x H x D (cm)</b>	<b>Mass (g)</b>	<b>Volume (cm<sup>3</sup>)</b>	<b>Connector Type</b>
K272	4.45 x 4.57 x 0.75	23.5	11.5	RA/RV: IS-1
K273	4.45 x 4.70 x 0.75	24.5	12.0	RA: IS-1; RV: IS-1
<b>MRI Model</b>				
K275	4.45 x 4.57 x 0.75	23.5	11.5	RA/RV: IS-1
K276	4.45 x 4.70 x 0.75	24.5	12.0	RA: IS-1; RV: IS-1

**Table 14. Mechanical Specifications - VITALIO EL Pacemakers**

<b>Model</b>	<b>Dimensions W x H x D (cm)</b>	<b>Mass (g)</b>	<b>Volume (cm<sup>3</sup>)</b>	<b>Connector Type</b>
K274	4.45 x 5.56 x 0.75	32.0	14.0	RA: IS-1; RV: IS-1
<b>MRI Model</b>				
K277	4.45 x 5.56 x 0.75	32.0	14.0	RA: IS-1; RV: IS-1

**Table 15. Mechanical Specifications - INGENIO Pacemakers**

<b>Model</b>	<b>Dimensions W x H x D (cm)</b>	<b>Mass (g)</b>	<b>Volume (cm<sup>3</sup>)</b>	<b>Connector Type</b>
K172	4.45 x 4.57 x 0.75	23.5	11.5	RA/RV: IS-1
K173	4.45 x 4.70 x 0.75	24.5	12.0	RA: IS-1; RV: IS-1
<b>MRI Model</b>				
K175	4.45 x 4.57 x 0.75	23.5	11.5	RA/RV: IS-1
K176	4.45 x 4.70 x 0.75	24.5	12.0	RA: IS-1; RV: IS-1

**Table 16. Mechanical Specifications - INGENIO EL Pacemakers**

<b>Model</b>	<b>Dimensions W x H x D (cm)</b>	<b>Mass (g)</b>	<b>Volume (cm<sup>3</sup>)</b>	<b>Connector Type</b>
K174	4.45 x 5.56 x 0.75	32.0	14.0	RA: IS-1; RV: IS-1
<b>MRI Model</b>				
K177	4.45 x 5.56 x 0.75	32.0	14.0	RA: IS-1; RV: IS-1

**Table 17. Mechanical Specifications - ADVANTIO Pacemakers**

Model	Dimensions W x H x D (cm)	Mass (g)	Volume (cm <sup>3</sup> )	Connector Type
K062	4.45 x 4.57 x 0.75	23.5	11.5	RA/RV: IS-1
K063	4.45 x 4.70 x 0.75	24.5	12.0	RA: IS-1; RV: IS-1

**Table 18. Mechanical Specifications - ADVANTIO EL Pacemakers**

Model	Dimensions W x H x D (cm)	Mass (g)	Volume (cm <sup>3</sup> )	Connector Type
K064	4.45 x 5.56 x 0.75	32.0	14.0	RA: IS-1; RV: IS-1

FORMIO, VITALIO, INGENIO, and ADVANTIO devices include ZIP telemetry operating with a transmit frequency of 916.5 MHz.

Material specifications are shown below:

- Case: hermetically sealed titanium
- Header: implantation-grade polymer
- Power Supply (FORMIO, VITALIO, INGENIO, and ADVANTIO) SR and DR models: lithium-carbon monofluoride-silver vanadium oxide cell; Greatbatch 2808
- Power Supply (FORMIO, VITALIO, INGENIO, and ADVANTIO) DR EL models: lithium-manganese dioxide cell; Boston Scientific; 402125

**ITEMS INCLUDED IN PACKAGE**

The following items are included with the pulse generator:

- One torque wrench
- Product literature

**NOTE:** Accessories (e.g., wrenches) are intended for one-time use only. They should not be resterilized or reused.

**WARNING:** Implant of the system cannot be performed in an MRI site Zone III (and higher) as defined by the American College of Radiology Guidance Document for Safe MR Practices<sup>4</sup>. Some of the accessories packaged with pulse generators and leads, including the torque wrench and stylet wires, are not MR Conditional and should not be brought into the MRI scanner room, the control room, or the MRI site Zone III or IV areas.

**SYMBOLS ON PACKAGING**

The following symbols may be used on packaging and labeling (Table 19 on page 44):







**Table 19. Symbols on packaging**

Symbol	Description
	Reference number

4. Kanal E, et al., American Journal of Roentgenology 188:1447-74, 2007.



Table 19. Symbols on packaging (continued)

Symbol	Description
	Package contents
	Pulse generator
	Torque wrench
	Literature enclosed
	Serial number
	Use by
	Lot number

**Table 19. Symbols on packaging** (continued)















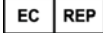

Symbol	Description
	Date of manufacture
	Sterilized using ethylene oxide
	Do not resterilize
	Do not reuse
	Do not use if package is damaged
	Consult instructions for use

Table 19. Symbols on packaging (continued)

Symbol	Description
	Temperature limitation
	Place telemetry wand here
	Open here
	Authorized Representative in the European Community
	Manufacturer
	MR Conditional

**Table 19. Symbols on packaging** (continued)

Symbol	Description
	Pacemaker RV
	Pacemaker RA, RV
	CRT-P RA, RV, LV
	Uncoated device
	RF Telemetry

**CHARACTERISTICS AS SHIPPED**

Refer to the table for pulse generator settings at shipment (Table 20 on page 49).

**Table 20. Characteristics as shipped**

<b>Parameter</b>	<b>Setting</b>
Pacing Mode	Storage
Pacing Therapy available	DDDR (DR models) SSIR (SR models)
Sensor	Blend (Accel and MV)
Pace/Sense Configuration	RA: BI/BI (DR models)
Pace/Sense Configuration	RV: BI/BI
Magnet Rate	100 ppm

The pulse generator is shipped in a power-saving Storage mode to extend its shelf life. In Storage mode, all features are inactive except:

- Telemetry support, which allows interrogation and programming
- Real-time clock
- STAT PACE command

The device leaves Storage mode when one of the following actions occurs; however, programming other parameters will not affect the Storage mode:

- STAT PACE is commanded
- The pulse generator automatically detects lead insertion (refer to "Implanting the Pulse Generator" on page 63)
- Device Mode is programmed to Exit Storage

Once you have programmed the pulse generator out of Storage mode, the device cannot be reprogrammed to that mode.

#### **X-RAY IDENTIFIER**

The pulse generator has an identifier that is visible on x-ray film or under fluoroscopy. This identifier provides noninvasive confirmation of the manufacturer and consists of the following:

- The letters, BSC, to identify Boston Scientific as the manufacturer
- NOTE:** *These letters are preceded by a filled triangle to indicate MR Conditional status.*
- The number, 012, for ACCOLADE, PROPONENT, ESSENTIO, and ALTRUA 2 pulse generators. This identifies the Model 2869 PRM software application needed to communicate with the pulse generator.
  - The number, 011, for FORMIO, VITALIO, INGENIO, and ADVANTIO pulse generators. This identifies the Model 2869 PRM software application needed to communicate with the pulse generator.

The x-ray identifier is embedded in the header of the device. For a left side pectoral implant, the identifier will be visible by x-ray or fluorography at the approximate location shown (Figure 1 on page 51).

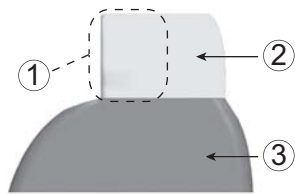

[1] X-Ray Identifier [2] Header [3] Pulse Generator Case

**Figure 1. X-ray identifier**

For information on identifying the device via the PRM, refer to the PRM Operator's Manual.

The pulse generator model number is stored in device memory and is shown on the PRM Summary screen once the pulse generator is interrogated.

**FEDERAL COMMUNICATIONS COMMISSION (FCC)**

This device complies with Title 47, Part 15 of the FCC rules. Operation is subject to the following two conditions:

- This device may not cause harmful interference, and
- This device must accept any interference received, including interference that may cause undesired operation.

For pulse generators operating with a transmit frequency of 402 to 405 MHz: this transmitter is authorized by rule under the Medical Device Radiocommunication Service (in part 95 of the FCC Rules) and must not cause harmful interference to stations operating in the 400.150–406.000 MHz band in the Meteorological Aids

(i.e., transmitters and receivers used to communicate weather data), the Meteorological Satellite, or the Earth Exploration Satellite Services and must accept interference that may be caused by such stations, including interference that may cause undesired operation. This transmitter shall be used only in accordance with the FCC Rules governing the Medical Device Radiocommunication Service. Analog and digital voice communications are prohibited. Although this transmitter has been approved by the Federal Communications Commission, there is no guarantee that it will not receive interference or that any particular transmission from this transmitter will be free from interference.

**CAUTION:** Changes or modifications not expressly approved by Boston Scientific could void the user's authority to operate the equipment.

ACCOLADE, PROPONENT, and ESSENTIO devices operate with a transmit frequency between 402 to 405 MHz and use FSK modulation. The FCC ID is ESCCRMU22814.

FORMIO, VITALIO, INGENIO, and ADVANTIO devices operate with a transmit frequency of 916.5 MHz and use ASK modulation. The FCC ID is ESCCRMV17311.

Wanded telemetry operates at 57 kHz and uses QPSK modulation.

#### **PULSE GENERATOR LONGEVITY**

Based on simulated studies, it is anticipated that these pulse generators have average longevity to explant as shown below.

The longevity expectations, which account for the energy used during manufacture and storage, apply at the conditions shown in the table along with the following:

- Assumes 60 ppm LRL, ventricular and atrial settings of 0.4 ms pacing Pulse Width; sensors On.
- These calculations also assume EGM Onset is on, and that the pulse generator spends 6 months in Storage mode during shipping and storage.

**The following longevity tables and conditions of use apply to ACCOLADE, PROPONENT, ESSENTIO, and ALTRUA 2 devices.**

52



**Table 21. Pulse generator life expectancy estimation (implant to explant)**

All Models <sup>a</sup>									
Pacing	Longevity (years) at 500 Ω, 750 Ω, and 1000 Ω Pacing Impedance								
	500 Ω			750 Ω			1000 Ω		
	SR	DR	DR EL	SR	DR	DR EL	SR	DR	DR EL
A and V Amplitudes 3.5 V									
50%	9.2	7.6	12.2	9.7	8.3	13.2	10.0	8.7	13.9
100%	7.9	5.9	9.5	8.6	6.8	10.9	9.1	7.4	11.8
A and V Amplitudes 2.5 V									
50%	10.0	8.8	14.0	10.4	9.3	14.8	10.5	9.5	15.2
100%	9.2	7.6	12.1	9.7	8.2	13.2	10.0	8.7	13.9

a. Assumes ZIP telemetry use for 1 hour at implant time and for 40 minutes annually for in-clinic follow-up checks.

Longevities at “worst case” settings of 5.0 V, 500 Ω, 1.0 ms are:

- At 70 ppm: 3.3 years for SR models; 1.8 years for DR models; 3.1 years for DR EL models
- At 100 ppm: 2.5 years for SR models; 1.2 years for DR models; 2.1 years for DR EL models

Longevities at an LRL of 70 ppm, 500  $\Omega$ , 0.5 ms, 100% paced, sensors On, and pacing mode most comprehensive are: SR models at 2.5 V = 8.6 years, at 5.0 V = 5.0 years; DR models at 2.5 V = 6.8 years, at 5.0 V = 3.0 years; DR EL models at 2.5 V = 10.9 years, at 5.0 V = 5.1 years.

**NOTE:** *The energy consumption in the longevity table is based upon theoretical electrical principles and verified via bench testing only.*

The pulse generator longevity may increase with a decrease in any of the following:

- Pacing rate
- Pacing pulse amplitude(s)
- Pacing pulse width(s)
- Percentage of paced to sensed events

Longevity is also affected in the following circumstances:

- A decrease in pacing impedance may reduce longevity.
- When the MV Sensor is programmed Off for the life of the device, longevity is increased by approximately 5 months.
- When Patient Triggered Monitor is programmed to On for 60 days, longevity is reduced by approximately 5 days.
- One hour of additional ZIP wandless telemetry reduces longevity by approximately 8 days.
- The following LATITUDE usage will decrease longevity by approximately 10 months: Daily Device Check on, monthly Full Interrogations (scheduled remote follow ups, and quarterly patient-initiated interrogations). Daily Device Checks and quarterly Full Interrogations will decrease longevity by approximately 9 months.
- Five patient-initiated LATITUDE Communicator interrogations per week for a year reduces longevity by approximately 40 days.
- 24 hours in MRI Protection Mode (with pacing On) reduces longevity by approximately 5 days.

54

- When RF telemetry is disabled for the life of the device, longevity is increased by 6 months (Altrua 2).
- An additional 6 months in Storage mode prior to implant will reduce longevity by 80 days. Assumes implanted settings of 60 ppm LRL, 2.5 V pacing pulse Amplitude and 0.4 ms pacing Pulse Width; 500  $\Omega$  pacing Impedance; 100% pacing.

Device longevity may also be affected by:

- Tolerances of electronic components
- Variations in programmed parameters
- Variations in usage as a result of patient condition

**The following longevity tables and conditions of use apply to FORMIO, VITALIO, INGENIO, and ADVANTIO devices.**

**Table 22. Pulse generator life expectancy estimation (implant to explant)**

All Models <sup>a b</sup>									
Pacing	Longevity (years) at 500 $\Omega$ , 750 $\Omega$ , and 1000 $\Omega$ Pacing Impedance								
	500 $\Omega$			750 $\Omega$			1000 $\Omega$		
	SR	DR	DR EL	SR	DR	DR EL	SR	DR	DR EL
A and V Amplitudes 3.5 V									
50%	8.5	7.0	9.9	9.0	7.5	10.7	9.2	7.8	11.2
100%	7.3	5.5	8.0	7.9	6.3	9.0	8.4	6.8	9.6

**Table 22. Pulse generator life expectancy estimation (implant to explant) (continued)**

All Models <sup>a b</sup>									
Pacing	Longevity (years) at 500 Ω, 750 Ω, and 1000 Ω Pacing Impedance								
	500 Ω			750 Ω			1000 Ω		
	SR	DR	DR EL	SR	DR	DR EL	SR	DR	DR EL
A and V Amplitudes 2.5 V									
50%	9.3	7.9	11.3	9.5	8.4	11.8	9.6	8.6	12.1
100%	8.5	6.9	9.8	8.9	7.5	10.7	9.2	7.9	11.2

- a. Assumes ZIP telemetry use for 1 hour at implant time and for 20 minutes during each quarterly follow-up  
 b. Assumes standard use of the LATITUDE Communicator as follows: Daily Alert Interrogation On, weekly scheduled remote follow ups, and quarterly patient-initiated interrogations.

Longevities at “worst case” settings of 5.0 V, 500 Ω, 1.0 ms are:

- At 70 ppm: 3.2 years for SR models; 1.7 years for DR models; 2.7 years for DR EL models
- At 100 ppm: 2.4 years for SR models; 1.1 years for DR models; 1.9 years for DR EL models

Longevities at an LRL of 70 ppm, 500 Ω, 0.5 ms, 100% paced, sensors On, and pacing mode most comprehensive are: SR models at 2.5 V = 7.9 years, at 5.0 V = 4.7 years; DR models at 2.5 V = 6.3 years, at 5.0 V = 2.9 years; DR EL models at 2.5 V = 8.9 years, at 5.0 V = 4.3 years.

**NOTE:** The energy consumption in the longevity table is based upon theoretical electrical principles and verified via bench testing only.

The pulse generator longevity may increase with a decrease in any of the following:

- Pacing rate
- Pacing pulse amplitude(s)
- Pacing pulse width(s)
- Percentage of paced to sensed events

Longevity is also affected in the following circumstances:

- A decrease in pacing impedance may reduce longevity.
- When the MV Sensor is programmed Off for the life of the device, longevity is increased by approximately 5 months.
- When Patient Triggered Monitor is programmed to On for 60 days, longevity is reduced by approximately 5 days.
- One hour of additional ZIP wandless telemetry reduces longevity by approximately 9 days.
- Five patient-initiated LATITUDE Communicator interrogations per week for a year reduces longevity by approximately 14 days.
- 24 hours in MRI Protection Mode (with pacing On) reduces longevity by approximately 5 days.
- An additional 6 months in Storage mode prior to implant will reduce longevity by 80 days. Assumes implanted settings of 60 ppm LRL, 2.5 V pacing pulse Amplitude and 0.4 ms pacing Pulse Width; 500  $\Omega$  pacing Impedance; 100% pacing.

Device longevity may also be affected by:

- Tolerances of electronic components
- Variations in programmed parameters
- Variations in usage as a result of patient condition

Refer to the PRM Summary and Battery Detail Summary screens for an estimate of pulse generator longevity specific to the implanted device.

#### **WARRANTY INFORMATION**

A limited warranty certificate for the pulse generator is available at [www.bostonscientific.com](http://www.bostonscientific.com). For a copy, contact Boston Scientific using the information on the back cover.

#### **PRODUCT RELIABILITY**

It is Boston Scientific's intent to provide implantable devices of high quality and reliability. However, these devices may exhibit malfunctions that may result in lost or compromised ability to deliver therapy. These malfunctions may include the following:

- Premature battery depletion
- Sensing or pacing issues
- Error codes
- Loss of telemetry

Refer to Boston Scientific's CRM Product Performance Report on [www.bostonscientific.com](http://www.bostonscientific.com) for more information about device performance, including the types and rates of malfunctions that these devices have experienced historically. While historical data may not be predictive of future device performance, such data can provide important context for understanding the overall reliability of these types of products.

Sometimes device malfunctions result in the issuance of product advisories. Boston Scientific determines the need to issue product advisories based on the estimated malfunction rate and the clinical implication of the malfunction. When Boston Scientific communicates product advisory information, the decision whether to replace a device should take into account the risks of the malfunction, the risks of the replacement procedure, and the performance to date of the replacement device.

#### **PATIENT COUNSELING INFORMATION**

The following topics should be discussed with the patient prior to discharge.

- External defibrillation—the patient should contact their physician to have their pulse generator system evaluated if they receive external defibrillation
- Signs and symptoms of infection
- Symptoms that should be reported (e.g., sustained high-rate pacing requiring reprogramming)
- Protected environments—the patient should seek medical guidance before entering areas protected by a warning notice that prevents entry by patients who have a pulse generator
- MRI scanning—the physician following the patient's device must be consulted to determine eligibility for an MRI scan
- Avoiding potential sources of EMI in home, work, and medical environments
- Reliability of their pulse generator ("Product Reliability" on page 58)
- Activity restrictions (if applicable)
- Minimum heart rate (lower rate limit of the pulse generator)
- Frequency of follow up
- Travel or relocation—Follow-up arrangements should be made in advance if the patient is leaving the country of implant
- Patient ID card—the patient should be advised to carry their patient ID card at all times (a temporary patient ID card is provided with the device, and a permanent ID card will be sent to the patient 4 to 6 weeks after the implant form is received by Boston Scientific)

**NOTE:** *Patients should present their patient ID card before entering protected environments such as for MRI scanning.*

### **Patient Handbook**

The Patient Handbook is provided for each device.

It is recommended that you discuss the information in the Patient Handbook with concerned individuals both before and after implantation so they are fully familiar with pulse generator operation.

In addition, for patients with an ImageReady MR Conditional Pacing System, an MRI Patient Guide is available.

For additional copies, contact Boston Scientific using the information on the back cover.

### **LEAD CONNECTIONS**

Lead connections are illustrated below.

**CAUTION:** Prior to implantation, confirm the lead-to-pulse generator compatibility. Using incompatible leads and pulse generators can damage the connector and/or result in potential adverse consequences, such as undersensing of cardiac activity or failure to deliver necessary therapy.

**NOTE:** *Use of Boston Scientific MR Conditional leads is required for an implanted system to be considered MR Conditional. Refer to the MRI Technical Guide for model numbers of pulse generators, leads, accessories, and other system components needed to satisfy the Conditions of Use.*

**CAUTION:** If the Lead Configuration is programmed to Bipolar when a unipolar lead is implanted, pacing will not occur.

**The following lead connections apply to ACCOLADE, PROPONENT, ESSENTIO, and ALTRUA 2 devices.**



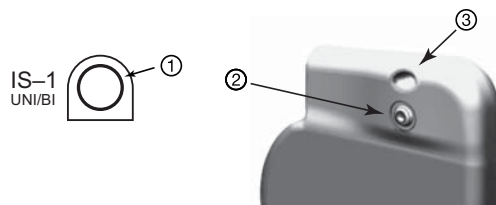

[1] RA/RV: White [2] RA/RV [3] Suture Hole

**Figure 2. Lead connections and setscrew locations, RA/RV: IS-1**

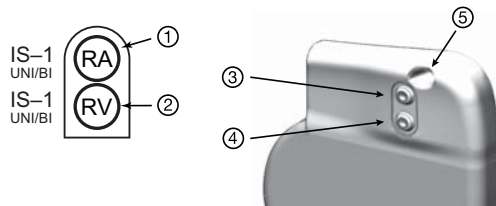

[1] RA: White [2] RV: White [3] RA [4] RV [5] Suture Hole

**Figure 3. Lead connections and setscrew locations, RA: IS-1, RV: IS-1**

The following lead connections apply to FORMIO, VITALIO, INGENIO, and ADVANTIO devices.



[1] RA/RV [2] Suture Hole

**Figure 4. Lead connections and setscrew locations, RA/RV: IS1**



[1] RA [2] RV [3] Suture Hole

**Figure 5. Lead connections and setscrew locations, RA: IS-1, RV: IS-1**

**NOTE:** The pulse generator case is used as a pace electrode when the pulse generator has been programmed to a unipolar lead setting.

#### **IMPLANTING THE PULSE GENERATOR**

Implant the pulse generator by performing the following steps in the sequence provided. Some patients may require pacing therapies immediately upon connecting the leads to the pulse generator. If modifications to the nominal settings are needed, consider programming the pulse generator before or in parallel with implanting the lead system and forming the implantation pocket.

**WARNING:** Implant of the system cannot be performed in an MRI site Zone III (and higher) as defined by the American College of Radiology Guidance Document for Safe MR Practices<sup>5</sup>. Some of the accessories packaged with pulse generators and leads, including the torque wrench and stylet wires, are not MR Conditional and should not be brought into the MRI scanner room, the control room, or the MRI site Zone III or IV areas.

5. Kanal E, et al., American Journal of Roentgenology 188:1447-74, 2007.

**Step A: Check Equipment**

It is recommended that instrumentation for cardiac monitoring, defibrillation, and lead signal measurement should be available during the implant procedure. This includes the PRM system with its related accessories and the software application. Before beginning the implantation procedure, become completely familiar with the operation of all the equipment and the information in the respective operator's and user's manuals. Verify the operational status of all equipment that may be used during the procedure. In case of accidental damage or contamination, the following should be available:

- Sterile duplicates of all implantable items
- Sterile wand
- Sterile PSA cables
- Torque and non-torque wrenches

During the implantation procedure, always have a standard transthoracic defibrillator with external pads or paddles available for use.

**Step B: Interrogate and Check the Pulse Generator**

To maintain sterility, test the pulse generator as described below before opening the sterile blister tray. The pulse generator should be at room temperature to ensure accurately measured parameters.

1. Interrogate the pulse generator using the PRM. Verify that the pulse generator's Device Mode is programmed to Storage. If otherwise, contact Boston Scientific using the information on the back cover.

To begin a ZIP telemetry session for ACCOLADE, PROPONENT, and ESSENTIO devices, verify that the ZOOM Wireless Transmitter is connected to the PRM via the USB cable and that the green light on top of the transmitter is illuminated. To initiate communication with all devices, position the wand over the PG and use the PRM to Interrogate the pulse generator. Keep the telemetry wand in position until either a message appears, indicating that the telemetry wand may be removed from proximity of the pulse generator, or the ZIP telemetry light illuminates on the PRM system. Select the End Session button to

quit a telemetry session and return to the startup screen. Radio frequency interference may temporarily disrupt ZIP telemetry communication. Increasing the distance from the source of interfering signals or repositioning the ZOOM Wireless Transmitter may improve ZIP telemetry performance. If ZIP telemetry performance is not satisfactory, the option of using wanded telemetry is available.

2. Review the pulse generator's current battery status. Counters should be at zero. If the pulse generator battery status is not at full capacity, do not implant the pulse generator. Contact Boston Scientific using the information on the back cover.
3. If a unipolar pacing configuration is required at implant, program the Lead Configuration to Unipolar before implant.

**Step C: Implant the Lead System**

The pulse generator requires a lead system for pacing and sensing.

Selection of lead configuration and specific surgical procedures is a matter of professional judgment. The following leads are available for use with the pulse generator depending on the device model.

- Unipolar or bipolar atrial lead
- Unipolar or bipolar right ventricular lead.

**NOTE:** *Single-chamber devices can be used with either an atrial or a ventricular lead.*

**NOTE:** *Using bipolar pacing leads will reduce the chance of myopotential sensing.*

**NOTE:** *Use of a unipolar lead with an ImageReady pulse generator is inconsistent with the Conditions of Use required for MR Conditional status. Refer to the MRI Technical Guide for warnings, precautions, and other information about MRI scanning.*

**NOTE:** Use of Boston Scientific MR Conditional leads is required for an implanted system to be considered MR Conditional. Refer to the MRI Technical Guide for model numbers of pulse generators, leads, accessories, and other system components needed to satisfy the Conditions of Use, and for warnings and precautions regarding MRI scanning.

**CAUTION:** The absence of a lead or plug in a lead port may affect device performance. If a lead is not used, be sure to properly insert a plug in the unused port, and then tighten the setscrew onto the plug.

**CAUTION:** If a dual-chamber device is programmed to AAI(R), ensure that a functional RV lead is present. In the absence of a functional RV lead, programming to AAI(R) may result in undersensing or oversensing.

**CAUTION:** Do not suture directly over the lead body, as this may cause structural damage. Use the suture sleeve to secure the lead proximal to the venous entry site to prevent lead movement.

Implant the leads via the surgical approach chosen.

When replacing a previously implanted pulse generator, it may be necessary to use an adapter to enable the new pulse generator to be connected to the existing leads. When using an adapter, follow the connection procedure described in the applicable adapter product data sheet. Always connect the adapter to the lead and repeat threshold and sensing measurements before connecting the adapter to the pulse generator.

**NOTE:** Should lead performance changes occur which cannot be resolved with programming, the lead may need to be replaced if no adapter is available.

**NOTE:** Use of adapters is inconsistent with the Conditions of Use required for MR Conditional status. Refer to the MRI Technical Guide for warnings, precautions, and other information about MRI scanning.

#### **Step D: Take Baseline Measurements**

Once the leads are implanted, take baseline measurements. Evaluate the lead signals. If performing a pulse generator replacement procedure, existing leads should be reevaluated, (e.g., signal amplitudes, pacing thresholds, and impedance). The use of radiography may help ensure lead position and integrity. If testing results are unsatisfactory, lead system repositioning or replacement may be required.

66

- Connect the pace/sense lead(s) to a pacing system analyzer (PSA).
- Pace/sense lead measurements, measured approximately 10 minutes after initial placement (acute) or during a replacement procedure (chronic), are listed below. Values other than what are suggested in the table may be clinically acceptable if appropriate sensing can be documented with the currently programmed values. Consider reprogramming the sensitivity parameter if inappropriate sensing is observed. Note that the pulse generator measurements may not exactly correlate to the PSA measurements due to signal filtering.

**Table 23. Lead measurements**

	<b>Pace/ sense lead (acute)</b>	<b>Pace/ sense lead (chronic)</b>
R-Wave Amplitude <sup>a b</sup>	> 5 mV	> 5 mV
P-Wave Amplitude <sup>a b</sup>	> 1.5 mV	> 1.5 mV
R-Wave Duration <sup>b c d</sup>	< 100 ms	< 100 ms
Pacing Threshold (right ventricle)	< 1.5 V endocardial < 2.0 V epicardial	< 3.0 V endocardial < 3.5 V epicardial
Pacing Threshold (atrium)	< 1.5 V endocardial	< 3.0 V endocardial
Lead impedance (at 5.0 V and 0.5 ms atrium and right ventricle)	> programmed Low Impedance Limit (200–500 Ω) < 2000 Ω (or the programmed High Impedance Limit (2000–3000 Ω))	> programmed Low Impedance Limit (200–500 Ω) < 2000 Ω (or the programmed High Impedance Limit (2000–3000 Ω))

- a. Amplitudes less than 2 mV cause inaccurate rate counting in the chronic state, and result in inability to sense a tachyarrhythmia or the misinterpretation of a normal rhythm as abnormal.
- b. Lower R-wave amplitudes and longer duration may be associated with placement in ischemic or scarred tissues. Since signal quality may deteriorate chronically, efforts should be made to meet the above criteria by repositioning the leads to obtain signals with the largest possible amplitude and shortest duration.
- c. Durations longer than 135 ms (the pulse generator's refractory period) may result in inaccurate cardiac rate determination, inability to sense a tachyarrhythmia, or in the misinterpretation of a normal rhythm as abnormal.
- d. This measurement is not inclusive of current of injury.

If the lead integrity is in question, standard lead troubleshooting tests should be used to assess the lead system integrity. Troubleshooting tests include, but are not limited to, the following:

- Electrogram analysis with pocket manipulation
- X-ray or fluoroscopic image review
- Invasive visual inspection

**Step E: Form the Implantation Pocket**

Using standard operating procedures to prepare an implantation pocket, choose the position of the pocket based on the implanted lead configuration and the patient's body habitus. Giving consideration to patient anatomy and pulse generator size and motion, gently coil any excess lead and place adjacent to the pulse generator. It is important to place the lead into the pocket in a manner that minimizes lead tension, twisting, sharp angles, and/or pressure. Pulse generators are typically implanted subcutaneously in order to minimize tissue trauma and facilitate explant. However, deeper implantation (e.g., subpectoral) may help avoid erosion or extrusion in some patients.

If an abdominal implant is suitable, it is recommended that implantation occur on the left abdominal side.

**NOTE:** *An abdominal implant site is inconsistent with the Conditions of Use for MR Conditional MRI scanning. Refer to the MRI Technical Guide for warnings, precautions and other information about MRI scanning.*

If it is necessary to tunnel the lead, consider the following:

68



- If a compatible tunneler is not used, cap the lead terminal pins. A Penrose drain, large chest tube, or tunneling tool may be used to tunnel the leads.
- Gently tunnel the leads subcutaneously to the implantation pocket, if necessary.
- Reevaluate all lead signals to determine if any of the leads have been damaged during the tunneling procedure.

If the leads are not connected to a pulse generator at the time of lead implantation, they must be capped before closing the incision.

**Step F: Connect the Leads to the Pulse Generator**

To connect leads to the pulse generator, use only the tools provided in the pulse generator sterile tray or accessory kit. Failure to use the supplied torque wrench may result in damage to the setscrews, seal plugs, or connector threads. Do not implant the pulse generator if the seal plugs appear to be damaged. Retain the tools until all testing procedures are complete and the pulse generator is implanted.

**Automatic Lead Detection**

Until a right ventricular lead is detected (or any appropriate lead in a single chamber device), the lead impedance is measured in both unipolar and bipolar configurations. Upon insertion of the lead into the header the impedance measurement circuit will detect an impedance which indicates that the device is implanted (automatic lead detection). If the impedance is in range (200 – 2000  $\Omega$ , inclusive) the pulse generator will automatically switch to the nominal parameters and start sensing and delivering therapy. The pulse generator can also be programmed out of the Storage mode prior to implant using the PRM.

**NOTE:** *If the lead being used for automatic lead detection is unipolar, an in-range impedance will not be obtained until the pulse generator is in stable contact with the subcutaneous tissue of the pocket.*

**NOTE:** *Arrhythmia Logbook and stored EGM data will not be stored for the first two hours after the lead is detected except for PaceSafe and patient triggered episodes.*

If the device is programmed out of Storage, asynchronous pacing spikes could be observed on intracardiac EGMs before bipolar RV lead insertion or before placing the pulse generator into the subcutaneous pocket if a unipolar RV lead is present. These subthreshold spikes will not occur once a bipolar RV lead is detected in the header or when contact between the pacemaker case and subcutaneous tissue completes the normal pacing circuit for a unipolar RV lead. If the device exits Storage as the result of automatic lead detection, the pulse generator may take up to 2 seconds plus one LRL interval before pacing begins as a result of lead detection.

Leads should be connected to the pulse generator in the following sequence (for pulse generator header and setscrew location illustrations, refer to "Lead Connections" on page 60):

**NOTE:** For single-chamber devices, use an RA or RV lead as appropriate.

- a. **Right ventricle.** Connect the RV lead first because it is required to establish RV-based timing cycles that yield appropriate sensing and pacing in all chambers, regardless of the programmed configuration.

**NOTE:** Tightening the RV setscrew is not required for automatic lead detection to occur but should be done to ensure full electrical contact.

- In models with an IS-1 RV lead port, insert and secure the terminal pin of an IS-1 RV pace/sense lead.

- b. **Right atrium.**

- In models with an IS-1 RA lead port, insert and secure the terminal pin of an IS-1 atrial pace/sense lead.

Connect each lead to the pulse generator by following these steps (for additional information about the torque wrench, refer to "Bidirectional Torque Wrench" on page 76):

- a. Check for the presence of any blood or other body fluids in the lead ports on the pulse generator header. If fluid inadvertently enters the ports, clean them thoroughly with sterile water.
- b. If applicable, remove and discard the tip protection before using the torque wrench.

70

- c. Gently insert the torque wrench blade into the setscrew by passing it through the preslit, center depression of the seal plug at a 90° angle (Figure 6 on page 71). This will open up the seal plug, relieving any potential pressure build-up from the lead port by providing a pathway to release trapped fluid or air.

**NOTE:** Failure to properly insert the torque wrench in the preslit depression of the seal plug may result in damage to the plug and its sealing properties.

**CAUTION:** Do not insert a lead into the pulse generator connector without taking the following precautions to ensure proper lead insertion:

- Insert the torque wrench into the preslit depression of the seal plug before inserting the lead into the port, to release any trapped fluid or air.
- Visually verify that the setscrew is sufficiently retracted to allow insertion. Use the torque wrench to loosen the setscrew if necessary.
- Fully insert each lead into its lead port and then tighten the setscrew onto the terminal pin.

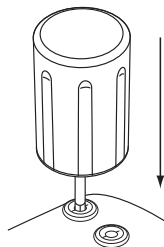

Figure 6. Inserting the torque wrench

- d. With the torque wrench in place, fully insert the lead terminal into the lead port. The lead terminal pin should be clearly visible beyond the connector block when viewed through the side of the EasyView pulse generator header. Place pressure on the lead to maintain its position and ensure that it remains fully inserted in the lead port.

**CAUTION:** Insert the lead terminal straight into the lead port. Do not bend the lead near the lead-header interface. Improper insertion can cause insulation or connector damage.

**NOTE:** *If necessary, lubricate the lead connectors sparingly with sterile water to make insertion easier.*

**NOTE:** *For IS-1 leads, be certain that the terminal pin visibly extends beyond the connector block at least 1 mm.*

- e. Apply gentle downward pressure on the torque wrench until the blade is fully engaged within the setscrew cavity, taking care to avoid damage to the seal plug. Tighten the setscrew by slowly turning the torque wrench clockwise, until it ratchets once. The torque wrench is preset to apply the proper amount of force to the captive setscrew; additional rotation and force is unnecessary.
- f. Remove the torque wrench.
- g. Apply gentle traction to the lead to ensure a secure connection.
- h. If the lead terminal is not secure, attempt to reseal the setscrew. Reinsert the torque wrench as described above, and loosen the setscrew by slowly turning the wrench counterclockwise, until the lead is loose. Then repeat the sequence above.
- i. If a lead port is not used, insert a plug into the unused port and tighten the setscrew.

**CAUTION:** The absence of a lead or plug in a lead port may affect device performance. If a lead is not used, be sure to properly insert a plug in the unused port, and then tighten the setscrew onto the plug.

**Step G: Evaluate Lead Signals**

1. Insert the pulse generator into the implantation pocket.

72

2. Evaluate the pace/sense lead signals by viewing the real-time EGMs and markers. Lead measurements should reflect those above (Table 23 on page 67).

Depending on the patient's intrinsic rhythm, it may be necessary to temporarily adjust pacing parameters to allow assessment of pacing and sensing. If proper pacing and/or sensing are not demonstrated, disconnect the lead from the pulse generator and visually inspect the connector and leads. If necessary, retest the lead.

**CAUTION:** Take care to ensure that artifacts from the ventricles are not present on the atrial channel, or atrial oversensing may result. If ventricular artifacts are present in the atrial channel, the atrial lead may need to be repositioned to minimize its interaction.

3. Evaluate all lead impedances.

For ACCOLADE, PROPONENT, ESSENTIO, and ALTRUA 2 devices, the High Impedance Limit is nominally set to 2000  $\Omega$ , and is programmable between 2000 and 3000  $\Omega$  in 250  $\Omega$  increments. The Low Impedance Limit is nominally set to 200  $\Omega$ , and is programmable between 200 and 500  $\Omega$  in 50  $\Omega$  increments.

For FORMIO, VITALIO, INGENIO, and ADVANTIO devices, the High Impedance Limit is fixed at 2000  $\Omega$ . The Low Impedance Limit is nominally set to 200  $\Omega$ , and is programmable between 200 and 500  $\Omega$  in 50  $\Omega$  increments.

Consider the following factors when choosing a value for the impedance limits:

- For chronic leads, historical impedance measurements for the lead, as well as other electrical performance indicators such as stability over time
- For newly implanted leads, the starting measured impedance value

**NOTE:** Depending on lead maturation effects, during follow-up testing the physician may choose to reprogram the impedance limits.

- Pacing dependence of the patient
- Recommended impedance range for the lead(s) being used, if available

**Step H: Program the Pulse Generator**

1. Check the Programmer Clock and set and synchronize the pulse generator as necessary so that the proper time appears on printed reports and PRM strip chart recordings.
2. Program the pulse generator appropriately if a lead port(s) is not used.

Consider the following when programming the pulse generator:

- The minimum 2X voltage or 3X pulse width safety margin is recommended for each chamber based on the capture thresholds, which should provide an adequate safety margin and help preserve battery longevity.
- Programming a longer blanking period may increase the likelihood of undersensing R-waves.
- Programming a shorter blanking period may increase the likelihood for ventricular oversensing of an atrial paced event.
- When programming MTR, consider the patient's condition, age, general health, sinus node function, and that a high MTR may be inappropriate for patients who experience angina or other symptoms of myocardial ischemia at higher rates.
- When programming MSR, consider the patient's condition, age, general health and that adaptive-rate pacing at higher rates may be inappropriate for patients who experience angina or other symptoms of myocardial ischemia at these higher rates. An appropriate MSR should be selected based on an assessment of the highest pacing rate that the patient can tolerate well.
- Programming long Atrial Refractory periods in combination with certain AV Delay periods can cause 2:1 block to occur abruptly at the programmed MTR.
- Prior to programming RVAC on, consider performing a Commanded Ventricular Automatic Capture Measurement to verify that the feature functions as expected.
- Using Fixed Sensing instead of AGC for patients who are pacemaker-dependent or have leads programmed to unipolar.

74

- In pacemaker-dependent patients, use care when considering setting Noise Response to Inhibit Pacing as pacing will not occur in the presence of noise.
- To resolve suspected impedance-based interactions with the MV Sensor, program the sensor to Off.

**Step I: Implant the Pulse Generator**

1. Verify magnet function and wand telemetry to ensure the pulse generator is within acceptable range to initiate interrogation.
2. Ensure that the pulse generator has good contact with surrounding tissue of the implantation pocket, and then suture it in place to minimize device migration (for suture hole location illustrations, refer to "Lead Connections" on page 60). Gently coil excess lead and place adjacent to the pulse generator. Flush the pocket with saline solution, if necessary, to avoid a dry pocket.

**WARNING:** Do not kink, twist, or braid the lead with other leads as doing so could cause lead insulation abrasion damage or conductor damage.

3. Close the implantation pocket. Consideration should be given to place the leads in a manner to prevent contact with suture materials. It is recommended that absorbable sutures be used for closure of tissue layers.
4. If Electrocautery mode was used during the implant procedure, cancel it when done.
5. Confirm final programmed parameters.

**CAUTION:** Following any Sensitivity parameter adjustment or any modification of the sensing lead, always verify appropriate sensing. Programming Sensitivity to the highest value (lowest sensitivity) may result in undersensing of cardiac activity. Likewise, programming to the lowest value (highest sensitivity) may result in oversensing of non-cardiac signals.

6. Use the PRM to print out parameter reports and save all patient data.

**Step J: Complete and Return the Implantation Form**

Within ten days of implantation, complete the Warranty Validation and Lead Registration form and return the original to Boston Scientific along with a copy of the patient data saved from the PRM. This information enables Boston Scientific to register each implanted pulse generator and set of leads, and provide clinical data on the performance of the implanted system. Keep a copy of the Warranty Validation and Lead Registration form and programmer printouts, and the original patient data for the patient's file.

Complete the temporary patient identification card and give it to the patient. After receiving the validation form, Boston Scientific sends the patient a permanent identification card.

**BIDIRECTIONAL TORQUE WRENCH**

A torque wrench (model 6628) is included in the sterile tray with the pulse generator, and is designed for tightening and loosening #2-56 setscrews, captured setscrews, and setscrews on this and other Boston Scientific pulse generators and lead accessories that have setscrews that spin freely when fully retracted (these setscrews typically have white seal plugs).

This torque wrench is bidirectional, and is preset to apply adequate torque to the setscrew and will ratchet when the setscrew is secure. The ratchet release mechanism prevents overtightening that could result in device damage. To facilitate the loosening of tight extended setscrews, this wrench applies more torque in the counterclockwise direction than in the clockwise direction.

**NOTE:** *As an additional safeguard, the tip of the torque wrench is designed to break off if used to overtighten beyond preset torque levels. If this occurs, the broken tip must be extracted from the setscrew using forceps.*

This torque wrench may also be used for loosening setscrews on other Boston Scientific pulse generators and lead accessories that have setscrews that tighten against a stop when fully retracted (these setscrews typically have clear seal plugs). However, when retracting these setscrews, stop turning the torque wrench when the setscrew has come in contact with the stop. The additional counterclockwise torque of this wrench may cause these setscrews to become stuck if tightened against the stop.



### **Loosening Stuck Setscrews**

Follow these steps to loosen stuck setscrews:

1. From a perpendicular position, tilt the torque wrench to the side 20° to 30° from the vertical center axis of the setscrew (Figure 7 on page 78).
2. Rotate the wrench clockwise (for retracted setscrew) or counterclockwise (for extended setscrew) around the axis three times, such that the handle of the wrench orbits the centerline of the screw (Figure 7 on page 78). The torque wrench handle should not turn or twist during this rotation.
3. As needed, you may attempt this up to four times with slightly more angle each time. If you cannot fully loosen the setscrew, use the #2 torque wrench from Wrench Kit Model 6501.
4. Once the setscrew has been freed, it may be extended or retracted as appropriate.
5. Discard the torque wrench upon completion of this procedure.

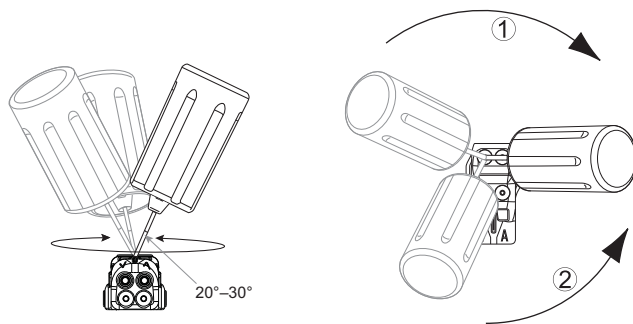

[1] Clockwise rotation to free setscrews stuck in the retracted position [2] Counterclockwise rotation to free setscrews stuck in the extended position

**Figure 7. Rotating the torque wrench to loosen a stuck setscrew**

#### **FOLLOW UP TESTING**

It is recommended that device functions be evaluated with periodic follow-up testing by trained personnel. Follow up guidance below will enable thorough review of device performance and associated patient health status throughout the life of the device.

### **Predischarge Follow Up**

The following procedures are typically performed during the predischarge follow up test using PRM telemetry:

1. Interrogate the pulse generator and review the Summary screen.
2. Verify pacing thresholds, lead impedance, and amplitude of intrinsic signals.
3. Review counters and histograms.
4. When all testing is complete, perform a final interrogation and save all the patient data.
5. Print the Quick Notes and Patient Data reports to retain in your files for future reference.
6. Clear the counters and histograms so that the most recent data will be displayed at the next follow up session. Counters and histograms can be cleared by pressing Reset on the Histogram screen, Tachy Counters screen, or Brady Counters screen.

### **Routine Follow Up**

During early and middle life of the device, monitor performance by routine follow up one month after the predischarge check and at least annually thereafter. Office visits may be supplemented by remote monitoring where available. As always, the physician should evaluate the patient's current health status, device status and parameter values, and local medical guidelines to determine the most appropriate follow up schedule.

When the device reaches One Year Remaining status and/or a Magnet Rate of 90 ppm is observed, follow up at least every three months to facilitate timely detection of replacement indicators.

**NOTE:** *Because the duration of the device replacement timer is three months (starting when Explant status is reached), three month follow up frequency is particularly important after the One Year Remaining status is reached.*

Consider performing the following procedures during a routine follow-up test:

1. Interrogate the pulse generator and review the Summary screen.

2. Verify pacing thresholds, lead impedance, and amplitude of intrinsic signals.
3. Print the Quick Notes and Patient Data reports to retain in your files for future reference.
4. Review the Arrhythmia Logbook screen and for episodes of interest, print episode details and stored electrogram information.
5. Clear the counters and histograms so that the most recent episode data will be displayed at the next follow-up session.
6. Verify that important programmed parameter values (e.g., Lower Rate Limit, AV Delay, Rate Adaptive Pacing, output Amplitude, Pulse Width, Sensitivity) are optimal for current patient status.

**NOTE:** *Echo-Doppler studies may be used to non-invasively evaluate AV Delay and other programming options post-implant.*

#### **EXPLANATION**

**NOTE:** *Return all explanted pulse generators and leads to Boston Scientific. Examination of explanted pulse generators and leads can provide information for continued improvement in system reliability and warranty considerations.*

**WARNING:** Do not reuse, reprocess, or resterilize. Reuse, reprocessing, or resterilization may compromise the structural integrity of the device and/or lead to device failure which, in turn, may result in patient injury, illness, or death. Reuse, reprocessing, or resterilization may also create a risk of contamination of the device and/or cause patient infection or cross-infection, including, but not limited to, the transmission of infectious disease(s) from one patient to another. Contamination of the device may lead to injury, illness, or death of the patient.

Contact Boston Scientific when any of the following occur:

- When a product is removed from service.
- In the event of patient death (regardless of cause), along with an autopsy report, if performed.

80

- For other observation or complications reasons.

**NOTE:** Disposal of explanted pulse generators and/or leads is subject to applicable laws and regulations. For a Returned Product Kit, contact Boston Scientific using the information on the back cover.

**NOTE:** Discoloration of the pulse generator may have occurred due to a normal process of anodization, and has no effect on the pulse generator function.

**CAUTION:** Be sure that the pulse generator is removed before cremation. Cremation and incineration temperatures might cause the pulse generator to explode.

**CAUTION:** Before explanting, cleaning, or shipping the device, complete the following actions to prevent overwriting of important therapy history data:

- Program the pulse generator Brady Mode to Off
- Program Ventricular Tachy EGM Storage to Off

Clean and disinfect the device using standard biohazard handling techniques.

Consider the following items when explanting and returning the pulse generator and/or lead:

- Interrogate the pulse generator and print a comprehensive report.
- Deactivate the pulse generator before explantation.
- Disconnect the leads from the pulse generator.
- If leads are explanted, attempt to remove them intact, and return them regardless of condition. Do not remove leads with hemostats or any other clamping tool that may damage the leads. Resort to tools only if manual manipulation cannot free the lead.
- Wash, but do not submerge, the pulse generator and leads to remove body fluids and debris using a disinfectant solution. Do not allow fluids to enter the pulse generator's lead ports.

- Use a Boston Scientific Returned Product Kit to properly package the pulse generator and/or lead, and send it to Boston Scientific.

82

Boston Scientific Confidential. Unauthorized use is prohibited.

**LIT APPROVAL - INGENIO 1-2 MRI PTM US**

Approved

1124977 A

Boston Scientific Confidential. Unauthorized use is prohibited.

**LIT APPROVAL - INGENIO 1-2 MRI PTM US**

Approved

1124977 A

# Boston Scientific

For additional reference information, go to  
[www.bostonscientific.com/ifu](http://www.bostonscientific.com/ifu).

Boston Scientific  
4100 Hamline Avenue North  
St. Paul, MN 55112-5798 USA

[www.bostonscientific.com](http://www.bostonscientific.com)

1.800.CARDIAC (227.3422)  
+1.651.582.4000

© 2014 Boston Scientific Corporation or its affiliates.  
All rights reserved.

359248-001 EN US 2014-09



Boston Scientific Confidential. Unauthorized use is prohibited.

**LIT APPROVAL - INGENIO 1-2 MRI PTM US**



**Boston  
Scientific**

CLINICAL SUMMARY

# **SAMURAI STUDY**

**CAUTION:** Federal law restricts this device to sale by or on the order of a physician trained or experienced in device implant and follow-up procedures.

Boston Scientific Confidential. Unauthorized use is prohibited.

**LIT APPROVAL-SAMURAI Clinical Study Summary**

Boston Scientific Confidential. Unauthorized use is prohibited.

**LIT APPROVAL-SAMURAI Clinical Study Summary**

## TABLE OF CONTENTS

CLINICAL STUDY - SUMMARY OF SAMURAI CLINICAL STUDY .....	1
STUDY DESIGN.....	1
METHODS .....	1
Subject Selection.....	1
Inclusion and Exclusion Criteria .....	1
SAMURAI Study Endpoints .....	2
Safety Endpoints .....	2
Effectiveness Endpoints .....	2
RESULTS .....	2
Subject Demographics .....	3
Study Endpoint Results .....	4
Safety Endpoint Results .....	4
Effectiveness Endpoint Results .....	6
ADVERSE EVENTS SUMMARY .....	10
SAMURAI Study .....	10
Lead-related Safety Data from INGEVITY and SAMURAI Studies .....	10
DEVICE DEFICIENCIES SUMMARY.....	11
DEATH SUMMARY .....	13
CONCLUSION .....	13
APPENDIX 1 LEAD MEASUREMENTS FROM IMPLANT THROUGH FOLLOW-UP .....	14
Pacing Threshold Data .....	14
Sensed Amplitude Data .....	15
Pacing Impedance Data .....	16
APPENDIX 2 IMPLANTATION QUESTIONNAIRE .....	18

The following are trademarks of Boston Scientific or its affiliates: IMAGEREADY, Ingenio, INGEVITY, VITALIO.

Boston Scientific Confidential. Unauthorized use is prohibited.

**LIT APPROVAL-SAMURAI Clinical Study Summary**

Boston Scientific Confidential. Unauthorized use is prohibited.

**LIT APPROVAL-SAMURAI Clinical Study Summary**

## CLINICAL STUDY - SUMMARY OF SAMURAI CLINICAL STUDY

The SAMURAI Clinical study was designed to collect data to confirm the safety, performance, and effectiveness of the ImageReady™ MR Conditional<sup>1</sup> Pacing System (hereafter referred to as the ImageReady System) when used in the MRI environment under the labeled Conditions of Use. The ImageReady System consists of specific Boston Scientific model components including pulse generators (the Ingenio™ MRI pulse generator family), leads (INGEVITY™ MRI pace/sense leads), accessories, the Programmer/Recorder/Monitor (PRM), and the PRM Software Application.

### STUDY DESIGN

The SAMURAI study is a prospective, open-label, two-group randomized clinical study continuing through 2019 with parallel groups at multiple centers globally. The overall study design included randomization of enrolled subjects at pre-discharge in a 2:1 ratio into the MRI Group or Control Group. An MRI/Control visit occurred 6-9 weeks after implant or lead revision or surgical modification of the ImageReady System. At this visit, MR scans were performed on subjects in the MRI Group. The MR scans were conducted in First-level Controlled Operating Mode (up to 4 W/kg whole body Specific Absorption Rate [SAR]), without requiring an anatomical isocenter exclusion zone (i.e., full body). Subsequent follow-up visits occurred at MRI/Control visit + 1 week and at MRI/Control visit + 1 Month. Safety and Effectiveness Endpoints were analyzed with these data. Additionally, subjects will be followed at the 1, 2, 3, 4, and 5 year post-implant clinic visits to continue evaluation of the ImageReady System after MR scans.

### METHODS

#### Subject Selection

The study enrolled patients from an investigator's general population with a Class I or II indication for a single or dual chamber pacemaker. Test pulse generators consisted of the VITALIO™ MRI pacemakers, which are part of the Ingenio MRI pulse generator family. The specific models of VITALIO MRI pacemakers included in the study contain a superset of the therapy features available in the Ingenio MRI pulse generator family. The test leads consisted of the INGEVITY MRI pace/sense leads, both active and passive fixation. Subjects who met all of the SAMURAI study inclusion criteria, and none of the exclusion criteria, were randomized in a 2:1 (MRI:Control) ratio and included in the endpoint analysis.

#### Inclusion and Exclusion Criteria

##### Inclusion Criteria

- Subject must have the ImageReady System as their initial (de novo) pacing system implant
- Subject has a Class I or II indication for implantation of a single or dual chamber pacemaker according to the American College of Cardiology (ACC)/American Heart Association (AHA)/Hearth Rhythm Society (HRS), or European Society of Cardiology (ESC) guidelines, as appropriate per geography
- Subject is able and willing to undergo an MR Scan without intravenous sedation (oral sedation may be used, if necessary, based on medical discretion)
- Subject is willing and capable of providing informed consent (which can include the use of a legally authorized representative [LAR] for documentation of informed consent) and participating in all testing/visits associated with this clinical study at an approved clinical study center and at the intervals defined by this protocol
- Subject is age 18 or above, or of legal age to give informed consent specific to state and national law

<sup>1</sup> As described in American Society for Testing and Materials (ASTM) F2503:2008, "Standard Practice for Marking Medical Devices and Other Items for Safety in the Magnetic Resonance Environment" ASTM International, West Conshohocken, PA, 2008, DOI: 10.1520/F2503-08, www.astm.org.

## CLINICAL STUDY - SUMMARY OF SAMURAI STUDY RESULTS

### Exclusion Criteria

- Subject has or has had any pacing or ICD system implants
- Subject has any MR Unsafe implants or devices with an unknown MR status, including MR Unsafe sternal wires, neurostimulators, biostimulator, metals or alloys, per labeling of each implant
- Subject has any MR Conditional implants or devices that impact the ability to conduct this protocol
- Subject needs or will need another MR scan within 14 weeks of system implant, other than that required by the SAMURAI Study
- Subject has a known or suspected sensitivity to dexamethasone acetate (DXA)
- Subject has a mechanical tricuspid heart valve
- Subject is enrolled in any other concurrent study, with the exception of local mandatory governmental registries and observational studies/registries that are not in conflict
- Subjects with documented permanent or persistent atrial fibrillation (AF)<sup>2</sup> where the physician intends to implant a dual chamber pulse generator [single chamber VVI(R) pulse generators are acceptable]
- Subject is currently on the active heart transplant list
- Subject has documented life expectancy of less than 12 months
- Women of childbearing potential who are or might be pregnant at the time of study enrollment or ImageReady System implant (method of assessment upon physician's discretion)
- Subjects currently requiring dialysis

### SAMURAI Study Endpoints

#### Safety Endpoints

- Primary Safety Endpoint: MR Scan-related ImageReady System Complication-Free Rate from MR Scan through the MRI visit + 1 Month (MRI Group only)
- Secondary Safety Endpoint: System-related Complication-Free Rate from Implant through 3 Months Post-Implant (MRI Group and Control Group)

#### Effectiveness Endpoints

The following endpoints were analyzed at the MRI/Control visit + 1 Month follow-up to establish effectiveness of the ImageReady System.

- Primary Effectiveness Endpoint 1: Change in Pacing Threshold (at 0.5 ms pulse width) Pre- and 1 Month post-MR Scan or Control Group visit compared between the MRI and Control Groups
- Primary Effectiveness Endpoint 2: Change in Sensed Amplitude Pre- and 1 Month Post-MR Scan or Control Group visit compared between MRI and Control Groups

## RESULTS

Results included in this SAMURAI Clinical study summary were collected through January 7, 2015. A summary of the subject disposition is shown in Figure 1 on page 3. A total of 363 subjects were enrolled at 41 centers in the study. Of those enrolled, 348 subjects were successfully implanted with the ImageReady System, and 347 subjects were randomized in a 2:1 ratio into the MRI Group or the Control Group.

2 Calkins H, et al. HRS/EHRA/ECAS expert Consensus Statement on catheter and surgical ablation of atrial fibrillation: recommendations for personnel, policy, procedures and follow-up. Heart Rhythm 4:816-861, 2007

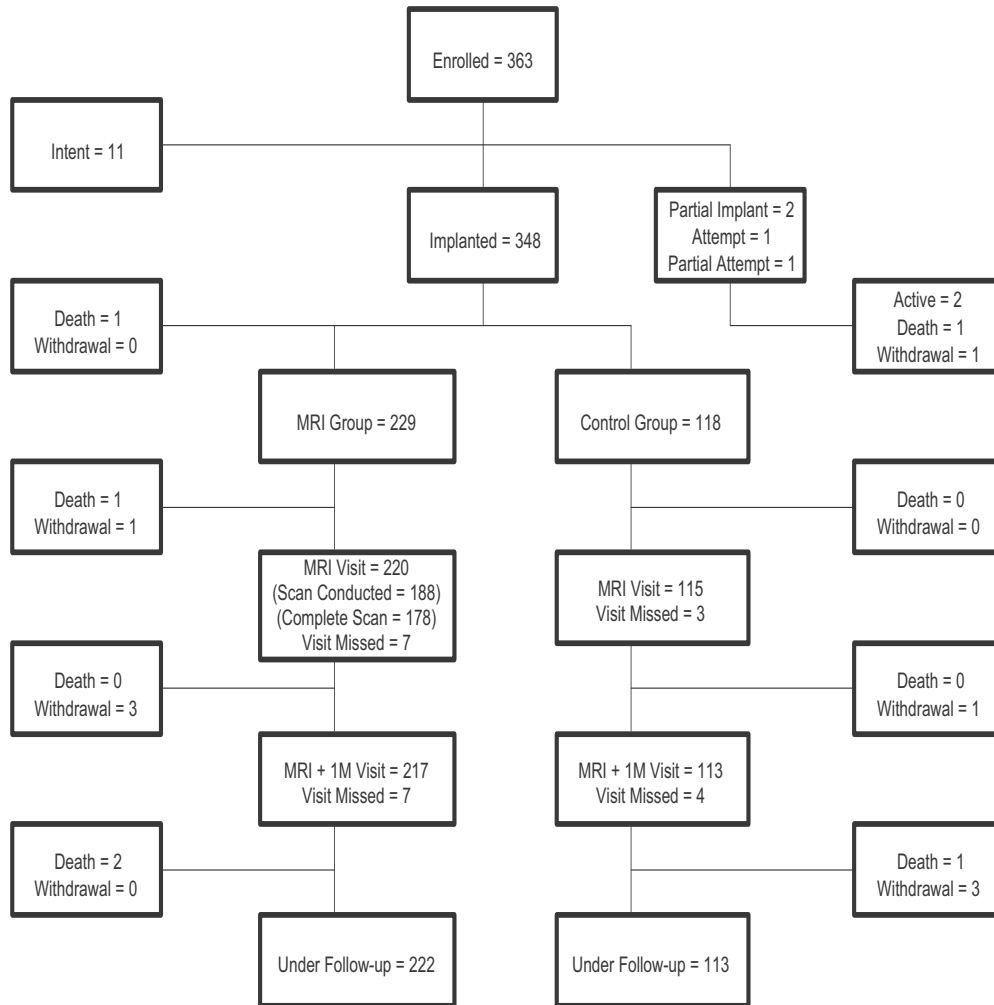

**Figure 1. Subject Disposition**

**Subject Demographics**

Overall, the average age of the subjects at implant was 69.4 ± 12.8 years, with an overall gender ratio of 46.6% females to 53.4% males (see Table 1 on page 3). Specifically in the MRI Group, the average age of the subjects at implant was 69.0 ± 13.0 years, with a gender ratio of 44.5% females to 55.5% males. In the Control Group, the average age of the subjects at implant was 70.4 ± 11.9 years, with a gender ratio of 53.4% females to 46.6% males.

**Table 1. Implanted Component Information and Subject Demographics**

Characteristic	Measurement	All Subjects	Randomized Groups	
			MRI Group	Control Group
Pulse Generator [N (%)]	Dual chamber	313 (89.4)	202 (88.2)	109 (92.4)
	Single chamber	37 (10.6)	27 (11.8)	9 (7.6)
Leads Implanted [N (%)]	Both RA and RV Leads	311 (88.9)	202 (88.2)	109 (92.4)
	RA only	3 (0.9)	3 (1.3)	0 (0.0)
	RV only	36 (10.3)	24 (10.5)	9 (7.6)

Characteristic	Measurement	All Subjects	Randomized Groups	
			MRI Group	Control Group
RA Fixation Type [N (%)]	Active	274 (87.3)	179 (87.3)	95 (87.2)
	Passive	40 (12.7)	26 (12.7)	14 (12.8)
RV Fixation Type [N (%)]	Active	284 (81.8)	184 (81.4)	98 (83.1)
	Passive	63 (18.2)	42 (18.6)	20 (16.9)
Age at Implant (years)	N	363	229	118
	Mean $\pm$ SD	69.4 $\pm$ 12.8	69.0 $\pm$ 13.0	70.4 $\pm$ 11.9
	Range	25.0-90.0	29.0-90.0	25.0-90.0
Gender [N (%)]	Female	169 (46.6)	102 (44.5)	63 (53.4)
	Male	194 (53.4)	127 (55.5)	55 (46.6)
Body Mass Index (kg/m <sup>2</sup> )	N	363	229	118
	Mean $\pm$ SD	28.4 $\pm$ 5.6	27.9 $\pm$ 5.2	29.3 $\pm$ 6.0
	Range	16.4-52.3	16.4-44.1	18.9-47.6

### Study Endpoint Results

Safety and Effectiveness Endpoint results are summarized below. All adverse events reported by the investigators were reviewed and classified by an internal committee. All reported complications were further adjudicated by the Independent Clinical Events Committee (CEC) for a relationship to the MR scan and for a relationship to the ImageReady System.

### Safety Endpoint Results

A summary of the Safety Endpoints results is shown in Table 2 on page 4, with details provided in the following sections.

**Table 2. Summary of Safety Endpoints Results**

Safety Endpoint	Measurement	Performance Goal	Result (Confidence Limit)	Conclusion
Primary	MR Scan-Related ImageReady System Complication-Free Rate (MRI Group)	> 95%	100% (95% One-sided Lower Confidence Limit = 100%)	Endpoint Met
Secondary	System-Related Complication-Free Rate (all implanted and attempted subjects)	> 80%	94.5% (95% One-sided Lower Confidence Limit = 92.0%)	Endpoint Met

### **Primary Safety Endpoint: MR Scan-related ImageReady System Complication-Free Rate from MR Scan through the MRI Visit + 1 Month (MRI Group only)**

The Primary Safety Endpoint for the SAMURAI study was assessed for all subjects randomized to the MRI Group who underwent any portion of the study protocol MR scan sequences, and did not have a medically necessary scan performed prior to the MRI visit + 1 Month follow-up. Safety was evaluated by the MR scan-related Complication-Free Rate (CFR) between the MR Scan and the MRI visit + 1 Month follow-up. For the purpose of this endpoint, a complication was defined as a detectable adverse event that could only be resolved by invasive intervention or that caused significant loss of device function. Complications that were determined to be associated with both MR scan and the ImageReady system were considered as MR scan-related complications and counted against this endpoint.

Boston Scientific Confidential. Unauthorized use is prohibited.

LIT APPROVAL-SAMURAI Clinical Study Summary



The MR Scan Related Complication-Free Rate from the time of the MR scan to the follow-up at MRI + 1 Month in the reporting sample was 100% with a 95% one-sided lower confidence limit of 100% (see Figure 2 on page 5).

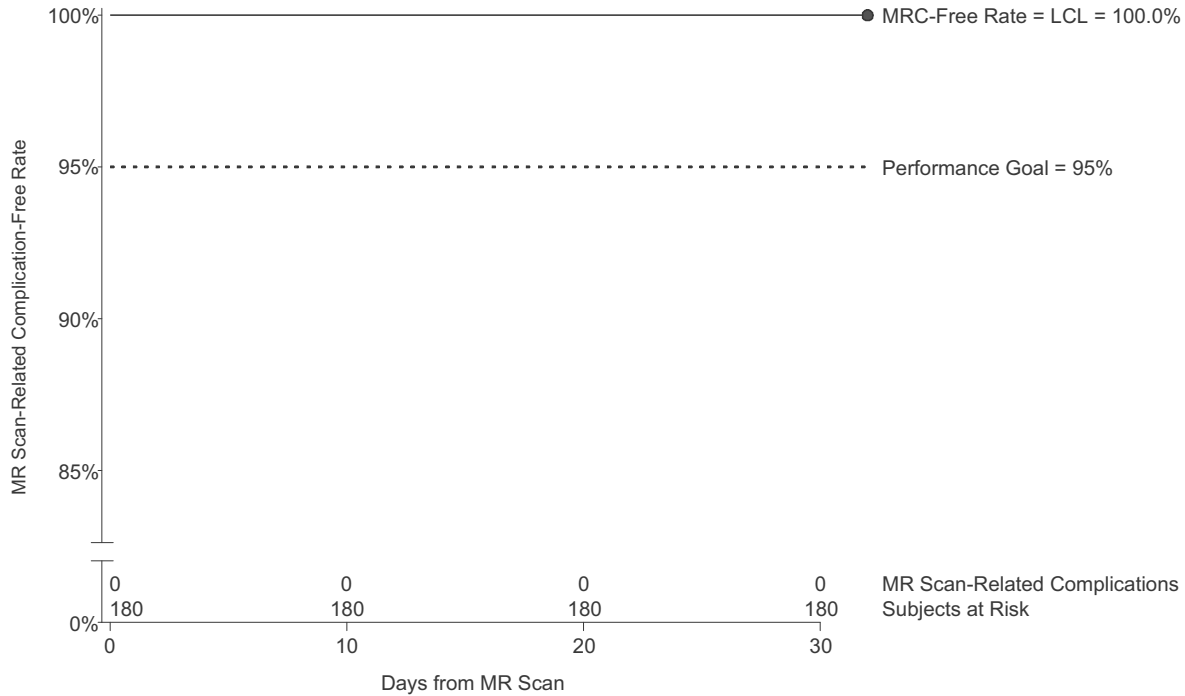

**Figure 2. Primary Safety Endpoint Results. – MR Scan-Related Complication-Free Rate from MR Scan through MRI Visit + 1 Month**

The data support the MRI safety of the ImageReady System when used in the MRI environment under the labeled Conditions of Use.

**Secondary Safety Endpoint: System-related Complication-Free Rate from Implant through 3 Months Post-Implant (MRI Group and Control Group)**

Overall safety of the ImageReady System was assessed by evaluation of system-related complications for both the MRI Group and the Control Group. A complication was defined as an adverse event that resulted in death, serious injury, correction using invasive intervention, or permanent loss of device functions. A system-related complication was a complication caused by either the implanted VITALIO MRI pacemaker or the INGEVITY MRI lead (collectively, the system). Any adverse events that occurred within 91 days of initial ImageReady System implant and adjudicated as a system-related complication counted against this endpoint. The performance goal for this safety endpoint was greater than 80%.

The system-related Complication-Free Rate from 0 to 3 months for all SAMURAI study subjects who underwent an implant procedure was 94.5% with a one-sided 95% lower confidence limit of 92.0% (see Figure 3 on page 6).

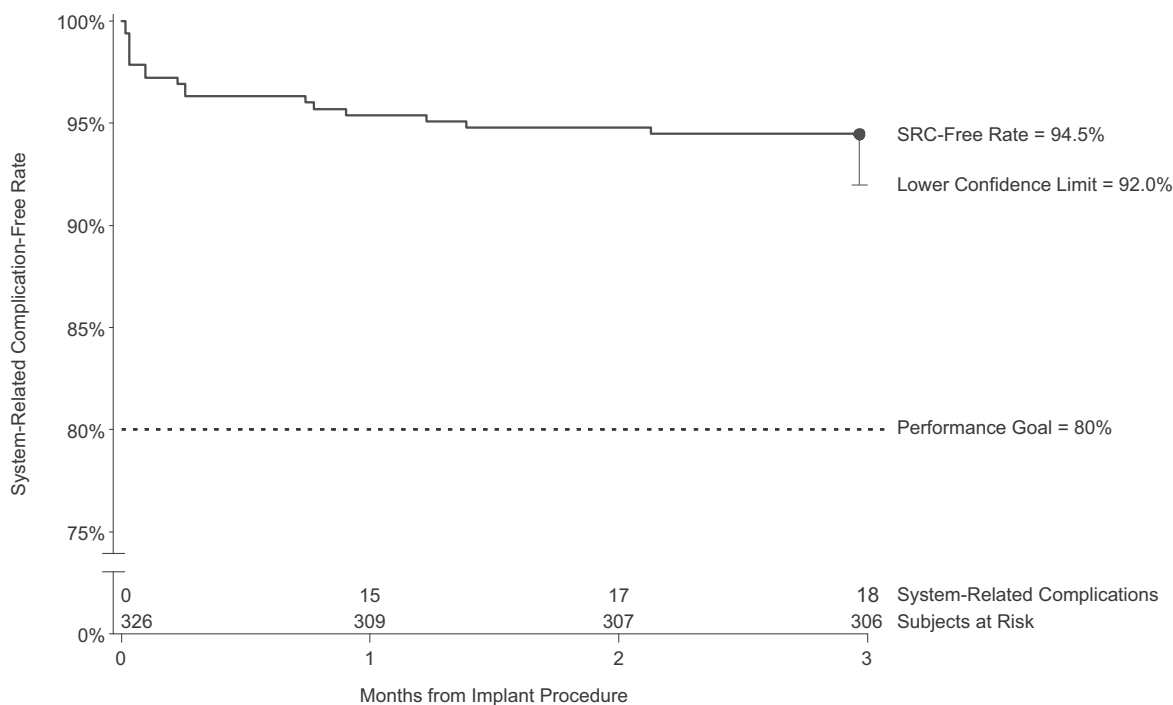

**Figure 3. Secondary Safety Endpoint Results. – System-Related Complication-Free Rate from Implant through 3 Months Post-implant**

The data support the overall safety of the ImageReady System.

**Effectiveness Endpoint Results**

The MR scan can result in damage to cardiac tissue surrounding lead electrodes due to RF field-induced heating, which in turn may cause elevated pacing thresholds. The Effectiveness Endpoints were set up to evaluate any chronic effects from lead heating that would be seen through increased pacing threshold or decreased sensed amplitude at the MRI/Control visit + 1 Month follow-up.

Primary Effectiveness Endpoints 1 and 2 were each analyzed by both an intention-to-treat (ITT) and per-protocol (PP) analysis. The ITT analysis analyzed subjects according to their assigned randomization group for all subjects who had pacing threshold or sensed amplitude measurements at both the MRI visit and the MRI/Control visit + 1 Month follow-up. The per-protocol analysis only included subjects who received their assigned randomization, and did not include subjects who met any of the following exclusions:

- Had a medically necessary scan between implant and the MRI/Control visit + 1 Month follow-up
- Failed to meet the labeled MRI Conditions of Use
- Experienced a lead-related complication between MRI/Control visit and the MRI/Control visit + 1 Month follow-up
- Had an incomplete scan based on the SAMURAI MR Scan Sequences protocol.

The difference in the success rate between the two randomization groups was compared to 10% using a one-sided Farrington-Manning score test for non-inferiority at a significance level of 0.05. A summary of the Effectiveness Endpoints results is shown in Table 3 on page 7, with details provided in the following sections.

**Table 3. Summary of Effectiveness Endpoint results.**

Effectiveness Endpoint	Measurement	Analysis Subgroup*	Difference Control-MRI (Upper One-sided 95% CI)	Conclusion
<b>Primary 1</b>	Pacing Threshold (difference in success rates between MRI and Control Groups)	ITT	-0.5% (3.3%)	Endpoint Met
		PP	-0.3% (3.9%)	Endpoint Met
<b>Primary 2</b>	Sensed Amplitude (difference in success rates between MRI and Control Groups)	ITT - Right Atrium	-0.1% (4.5%)	Endpoint Met
		ITT - Right Ventricle	0.7% (5.0%)	Endpoint Met
		PP - Right Atrium	-0.2% (4.9%)	Endpoint Met
		PP - Right Ventricle	-0.0% (4.7%)	Endpoint Met

\* ITT (Intention to Treat), PP (Per Protocol)

**Primary Effectiveness Endpoint 1 - Pre- vs. 1 Month Post-MR Scan/Control Group Visit Pacing Threshold at 0.5 ms**

Changes in pacing threshold (at 0.5 ms) pre- and 1 Month post-MR Scan or Control Group visit were compared between the MRI and Control Groups. Three pacing threshold measurements taken at each of the two visits (pre-MR Scan/Control Group visit and the MRI/Control visit + 1 Month follow-up) were averaged to determine the average pacing threshold at each visit for each subject. The lead fixation type and lead chamber data were pooled for this endpoint since the passive and active fixation INGEVITY MRI leads, as well as the RA and RV leads, were expected to perform similarly regarding any effect of MRI on pacing threshold.

Subjects with an increase in pacing thresholds  $\leq 0.5V$  (at 0.5 ms) from pre-MR Scan/Control Group visit to MRI/Control visit + 1 Month follow-up were considered a success. A success rate was calculated for both the MRI and the Control Groups. Subjects with more than one investigational lead were counted as a failure if either lead failed to meet the success criteria.

A total of 100 Control Group subjects and 204 MRI Group subjects had paired threshold measurements and were included in the ITT endpoint analysis. The success rate in the Control group was 98.0%, and 98.5% in the MRI group, resulting in a difference of -0.5% and an upper one-sided 95% confidence interval of 3.3%. The Farrington-Manning score test resulted in a p-value  $< 0.0001$ .

For the per-protocol analysis, a total of 95 Control Group subjects and 167 MRI Group subjects had paired threshold measurements and met the inclusion criteria. The success rate in the Control group was 97.9%, and 98.2 % in the MRI group, resulting in a difference of -0.3% and an upper one-sided 95% confidence interval of 3.9%. The Farrington-Manning score test resulted in a p-value  $< 0.0001$ . Endpoint results are presented in Figure 4 on page 8.

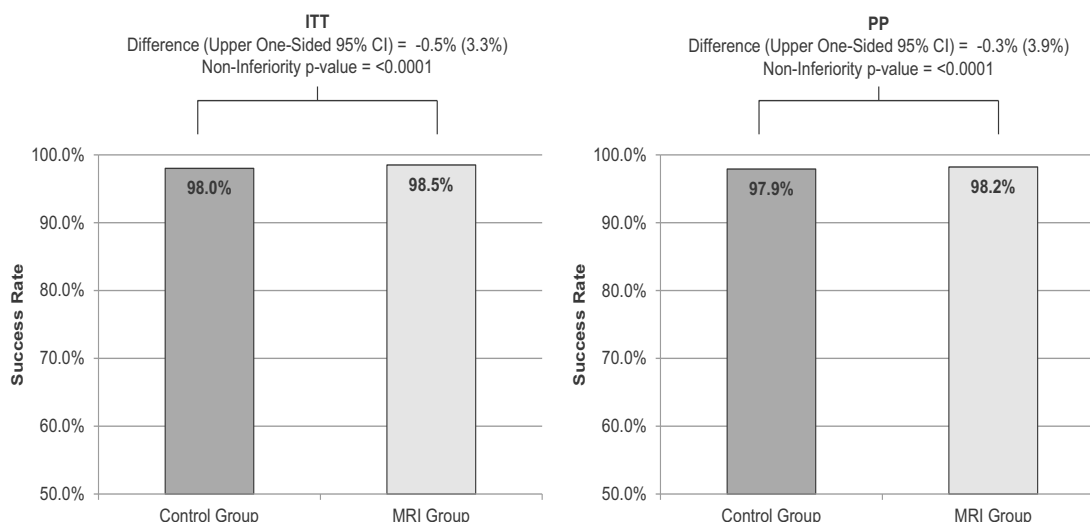

**Figure 4. Primary Effectiveness Endpoint 1 Results – Success Rates of Changes in Pacing Threshold (at 0.5 ms pulse width) Pre- and 1 Month post-MR Scan or Control Group Visit compared between the MRI and Control Groups (ITT and PP analyses).**

The success rates for the threshold measurement results observed for both the MRI Group and the Control Group were comparable, and the difference between the groups was lower than the non-inferiority margin of 10%. The data support the effectiveness of the ImageReady System with respect to stable pacing thresholds pre- and post-MR scan (a surrogate measurement for clinical effects of lead heating) when subjects were scanned according to the MRI Conditions of Use.

#### **Primary Effectiveness Endpoint 2 - Pre- vs. 1 Month Post-MR Scan/Control Group Visit Sensed Amplitude**

Changes in sensed amplitude pre- and 1 Month post-MR Scan or Control Group visit were compared between the MRI and Control Groups. Three sensed amplitude measurements taken at each of the two visits (pre-MR Scan/Control Group visit and the MRI/Control visit + 1 Month follow-up) were averaged to determine the average sensed amplitude at each visit for each subject. Data were analyzed separately by chamber for this endpoint, while the lead fixation type data were pooled since the passive and active fixation INGEVITY MRI leads were expected to perform similarly regarding any effect of MRI on sensed amplitude. A success rate was calculated for the MRI Group and for the Control Group. Subjects with more than one investigational lead were counted as a failure if either lead failed to meet the success criteria.

For atrial sensed amplitudes, a subject was considered a success if the sensed amplitude at the MRI/Control visit + 1 Month follow-up remained  $\geq 1.0$  mV and above 50% of the pre-MR scan/Control Group visit value. There were 250 subjects (82 Control and 168 MRI) included in the ITT endpoint analysis, and 212 subjects (77 Control and 135 MRI) included in the per protocol endpoint analysis of the right atrial sensed amplitude. For the ITT analysis, the success rate in the Control Group was 96.3%, and 96.4% in the MRI Group, resulting in a difference of -0.1% and an upper one-sided 95% confidence interval of 4.5%. For the per protocol analysis, the success rate in the Control Group was 96.1%, and 96.3% in the MRI group, resulting in a difference of -0.2% and an upper one-sided 95% confidence interval of 4.9%. The p-values were 0.0001 and 0.0006 respectively for the ITT and the per protocol endpoint analyses of the right atrial sensed amplitude as shown in Figure 5 on page 9.

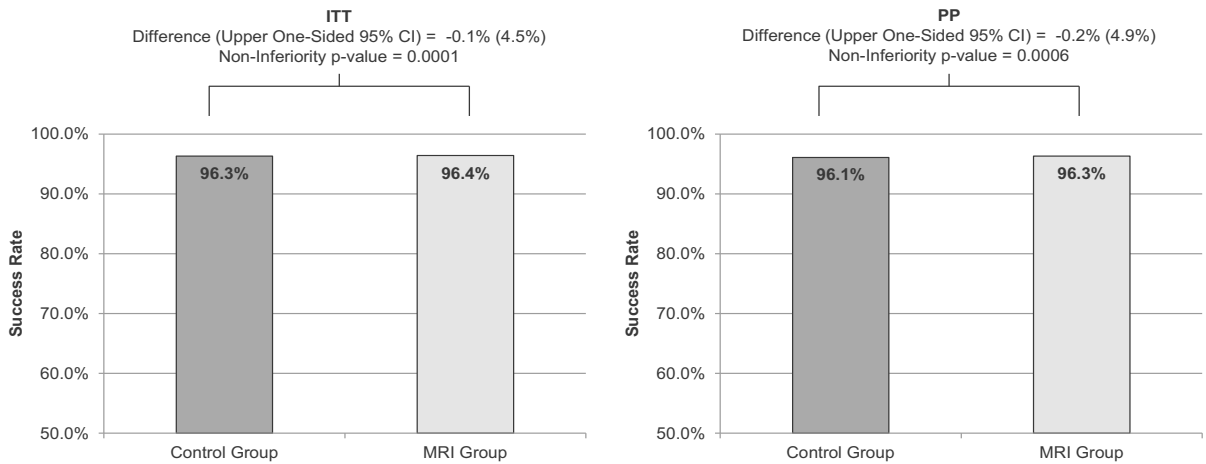

**Figure 5. Primary Effectiveness Endpoint 2 RA Results – Success Rates of Changes in Sensed Amplitude Pre- and 1 Month post-MR Scan or Control Group Visit compared between the MRI and Control Groups (ITT and PP analyses).**

For ventricular sensed amplitudes, a subject was considered a success if the sensed amplitude at the MRI/Control visit + 1 Month follow-up remained  $\geq 5.0$  mV and above 50% of the pre-MR scan/Control Group visit value. There were 277 subjects (95 Control and 182 MRI) included in the ITT endpoint analysis, and 242 subjects (90 Control and 152 MRI) included in the per protocol endpoint analysis of the right ventricular sensed amplitude. For the ITT analysis, the success rate in the Control Group was 96.8%, and 96.2% in the MRI Group, resulting in a difference of 0.7% (rounded) and an upper one-sided 95% confidence interval of 5.0%. For the per protocol analysis, the success rate in the Control Group was 96.7%, and 96.7% in the MRI group, resulting in a difference of -0.0% and an upper one-sided 95% confidence interval of 4.7%. The p-values were 0.0002 and 0.0002 respectively for the ITT and the per protocol endpoint analyses of the right ventricular sensed amplitude as shown in Figure 6 on page 9.

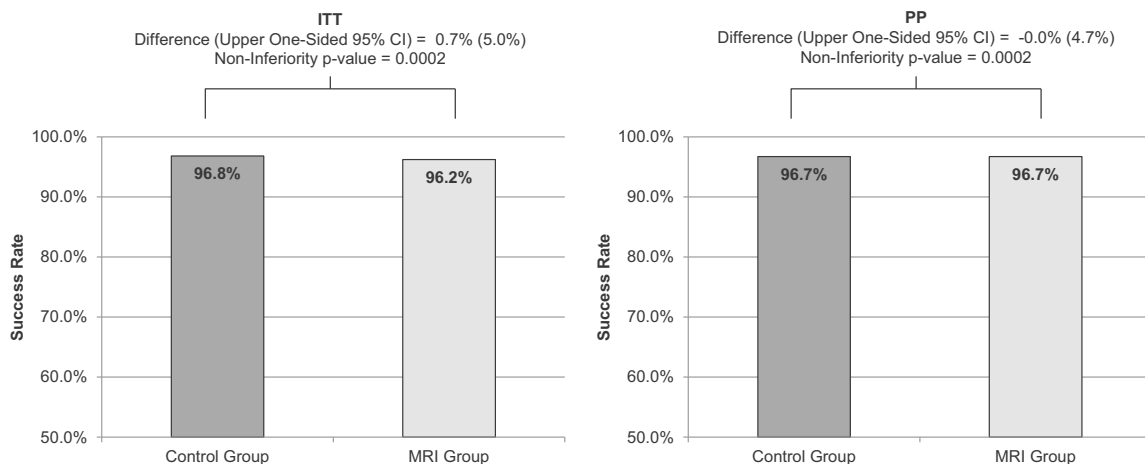

**Figure 6. Primary Effectiveness Endpoint 2 RV Results – Success Rates of Changes in Sensed Amplitude Pre- and 1 Month post-MR Scan or Control Group Visit compared between the MRI and Control Groups (ITT and PP analyses).**

Boston Scientific Confidential. Unauthorized use is prohibited.

LIT APPROVAL-SAMURAI Clinical Study Summary

## CLINICAL STUDY - SUMMARY OF SAMURAI STUDY ADVERSE EVENTS SUMMARY

The success rates for the sensed amplitude results observed for both for the MRI Group and the Control Group were comparable for each lead implant location, and the differences between the groups were lower than the non-inferiority margin of 10%. The data support the effectiveness of the ImageReady System with respect to stable sensed amplitudes pre- and post-MR scan (a surrogate measurement for clinical effects of lead heating) when subjects were scanned according to the MRI Conditions of Use.

## ADVERSE EVENTS SUMMARY

### SAMURAI Study

A summary of Adverse Events by Complication and Observation is shown in Table 4 on page 10. As of January 7, 2015, of the 351 implanted or partial/attempted subjects, there were no reported MRI-related complications. Further, of this group, 96.0% were free from adverse events related to the pacemaker, 89.7% were free from adverse events related to the implant procedure, and 94.9% and 96.3% were free from adverse events related to the INGEVITY MRI RA and RV leads, respectively.

All adverse events were reviewed by an independent committee, the SAMURAI Data Monitoring Committee (DMC). During the course of the SAMURAI study, the DMC did not identify any serious risks to subjects.

**Table 4. Adverse Events Summary: Clinical Complications and Observations**

Relationship	Total		Classification			
			Complication		Observation	
	Events	N (%)	Events	N (%)	Events	N (%)
Total (N at risk = 351)	519	209 (59.5%)	147	84 (23.9%)	372	179 (51.0%)
PG (N at risk = 351)	16	14 (4.0%)	0	0 (0.0%)	16	14 (4.0%)
RA Lead (N at risk = 314)	16	16 (5.1%)	7	7 (2.2%)	9	9 (2.9%)
RV Lead (N at risk = 347)	14	13 (3.7%)	8	8 (2.3%)	6	6 (1.7%)
Procedure (N at risk = 351)	46	36 (10.3%)	12	11 (3.1%)	34	28 (8.0%)
Protocol Testing (N at risk = 351)	5	5 (1.4%)	0	0 (0.0%)	5	5 (1.4%)
Cardiovascular - HF (N at risk = 351)	24	19 (5.4%)	16	13 (3.7%)	8	7 (2.0%)
Cardiovascular - Non-HF (N at risk = 351)	189	116 (33.0%)	36	30 (8.5%)	153	104 (29.6%)
Non-cardiovascular (N at risk = 351)	193	95 (27.1%)	62	31 (8.8%)	131	74 (21.1%)
Other (N at risk = 351)	16	13 (3.7%)	6	5 (1.4%)	10	8 (2.3%)

### Lead-related Safety Data from INGEVITY and SAMURAI Studies

Data collected in the SAMURAI study provided additional evidence to support the safety of INGEVITY pace/sense leads as analyzed in another Boston Scientific clinical study, the INGEVITY Active Fixation and Passive Fixation Pace/Sense Lead Clinical Study (hereafter referred to as the INGEVITY study). The INGEVITY study was designed to establish the safety, performance, and effectiveness of INGEVITY active and passive fixation pace/sense leads. INGEVITY MRI pace/sense leads are a component of the ImageReady System examined in the SAMURAI study, and are identical in design to INGEVITY pace/sense leads with the exception of the product-specific markings. Therefore, lead-related safety data collected in the SAMURAI study are applicable to INGEVITY pace/sense leads. Table 5 on page 11 is a summary of

LIT APPROVAL-SAMURAI Clinical Study Summary

comparable safety data across the two studies. Data are presented as the “number of leads with events / total number of leads eligible for safety analysis (% of total)”. The median follow-up time for the INGEVITY study was 18 months, and the median follow-up time for the SAMURAI study was 10 months.

**Table 5. Summary of Safety Data for the INGEVITY study and the SAMURAI study.**

Adverse Event	Leads Included	INGEVITY	SAMURAI	Total of both
Lead-Related Adverse Event	All Leads	60/1599 (3.75%)	33/665 (4.96%)	93/2264 (4.11%)
– Lead-Related Complication	All Leads	29/1599 (1.81%)	19/665 (2.86%)	48/2264 (2.12%)
Dislodgement	All Leads	20/1599 (1.25%)	7/665 (1.05%)	27/2264 (1.19%)
Perforation/Pericardial Effusion	Active Fixation Leads	4/1270 (0.31%)	7/563 (1.24%)	11/1833 (0.60%)
– Perforation	Active Fixation Leads	0/1270 (0.00%)	7/563 (1.24%)	7/1833 (0.38%)
– Pericardial Effusion	Active Fixation Leads	4/1270 (0.31%)	0/563 (0.00%)	4/1833 (0.22%)
Conductor Coil Fracture	All Leads	1*/1599 (0.06%)	0/665 (0.00%)	1/2264 (0.04%)

\*One conductor coil fracture occurred in the INGEVITY study, and was classified as a ventricular lead fracture at the costoclavicular junction, consistent with subclavian crush.

Note: The leads eligible for safety analysis include a maximum of one lead per subject per chamber.

Similar lead-related adverse events results were obtained in both the INGEVITY study and the SAMURAI study. Therefore, the data from the SAMURAI study further support the safety of the INGEVITY lead.

## DEVICE DEFICIENCIES SUMMARY

The INGEVITY study and the SAMURAI study each collected device deficiencies. Per ISO 14155, a device deficiency was defined as any inadequacy of a medical device with respect to its identity, quality, durability, reliability, safety or performance. Device deficiencies include malfunctions, misuse or use errors, and inadequate labeling. Per ISO 14155, device deficiencies and adverse events have unique definitions. Therefore, device deficiencies were separately reported from adverse events.

Table 6 on page 12 is a summary of device deficiencies reported in the INGEVITY study, the SAMURAI study, and the two studies combined. Data are presented as the “number of leads with deficiencies/total number of leads implanted and attempted (% of total)”. The rate of occurrence of device deficiencies across both studies was 6.4%. Some examples of device deficiencies include poor visibility of suture sleeve, inability to place the lead, and difficulty with helix extension/retraction. The most common device deficiency observed was difficulty with helix extension/retraction, 3.9% for the INGEVITY study, 6.8% for the SAMURAI study, and 4.8% across both studies.

Some of these helix extension/retraction device deficiencies resulted in lead conductor coil breaks, which were consistent with acute overload and not flex fatigue fracture. The rate of occurrence of lead conductor coil breaks was 1.6% for the INGEVITY study, 3.3% for the SAMURAI study, and 2.1% across both studies. In each case of conductor coil break, inadequate functionality of the lead was identified prior to pocket closure and the lead was removed from service. The leads were subsequently determined to have broken coils based on return product analysis.

CLINICAL STUDY - SUMMARY OF SAMURAI STUDY  
**DEVICE DEFICIENCIES SUMMARY**

Analysis of study data did not show an elevated safety risk of death, adverse events, serious adverse events, or complication for subjects with a helix extension/retraction device deficiency or a lead conductor coil break when compared to those who did not experience a helix extension/retraction device deficiency or lead conductor coil break.

To mitigate the extension/retraction device deficiencies, manufacturing improvements were made and the instructions for use were clarified. For marketed INGEVITY lead performance data including occurrence of conductor coil breaks, see the Boston Scientific Rhythm Management Product Performance Report at [www.bostonscientific.com/ppr](http://www.bostonscientific.com/ppr).

**Table 6. Summary of Device Deficiencies for the INGEVITY study and the SAMURAI study**

Device Deficiency	Leads Included	INGEVITY	SAMURAI	Total of both
All Reported	All	98/1656 (5.9%)	54/705 (7.7%)	152/2361 (6.4%)
- Active Fixation	Active Fixation	91/1322 (6.9%)	54/601 (9.0%)	145/1923 (7.5%)
- Passive Fixation	Passive Fixation	7/334 (2.1%)	0/104 (0.0%)	7/438 (1.6%)
Helix Extension/ Retraction	Active Fixation	52/1322 (3.9%)	41/601 (6.8%)	93/1923 (4.8%)
- Right Atrium	RA Active Fixation	36/475 (7.6%)	23/299 (7.7%)	59/774 (7.6%)
- Right Ventricle	RV Active Fixation	16/847 (1.9%)	18/302 (6.0%)	34/1149 (3.0%)
Coil Breaks*	Active Fixation	21/1322 (1.6%)	20/601 (3.3%)	41/1923 (2.1%)
- Right Atrium	RA Active Fixation	14/475 (2.9%)	11/299 (3.7%)	25/774 (3.2%)
- Right Ventricle	RV Active Fixation	7/847 (0.8%)	9/302 (3.0%)	16/1149 (1.4%)

\*Coil Breaks are a subset of Helix Extension/Retraction device deficiencies.

Note: All implanted and attempted leads are included.



## DEATH SUMMARY

As of January 7, 2015, six SAMURAI study subjects had died (1.7% of all enrolled subjects). Table 7 on page 13 provides an overview of all subject deaths that occurred in the SAMURAI study. Death information was provided per the case report forms (site information and an external Clinical Events Committee [CEC] adjudication). No deaths were attributed to an MR scan.

**Table 7. Summary of Study Deaths (N = 363 Enrolled Subjects)**

Cause of Death	Classification N (%)	MRI Related		System Related	
		Yes N (%)	Unknown N (%)	Yes N (%)	Unknown N (%)
Non Cardiac	3 (0.8%)	0 (0.0%)	0 (0.0%)	0 (0.0%)	0 (0.0%)
Cardiac: Ischemic	1 (0.3%)	0 (0.0%)	0 (0.0%)	0 (0.0%)	0 (0.0%)
Cardiac: Unknown	1 (0.3%)	0 (0.0%)	0 (0.0%)	0 (0.0%)	1 (0.3%)
Unknown	1 (0.3%)	0 (0.0%)	0 (0.0%)	0 (0.0%)	0 (0.0%)
<b>Total</b>	<b>6 (1.7%)</b>	<b>0 (0.0%)</b>	<b>0 (0.0%)</b>	<b>0 (0.0%)</b>	<b>1 (0.3%)</b>

## CONCLUSION

The results from this SAMURAI clinical study performed with the ImageReady MR Conditional Pacing System indicate that all the Safety Endpoints and all the Effectiveness Endpoints were met. Safety was assessed by determination of the MR scan-related and the overall ImageReady System-related complication-free rates. Effectiveness was analyzed by comparison of the differences in the success rates for pacing threshold and for sensed amplitude between the MRI Group and the Control Group. All performance goals were met for all Endpoints. Therefore, this study demonstrated the overall safety and effectiveness of the ImageReady MR Conditional Pacing System, with clinical performance similar to approved devices.

**APPENDIX 1 LEAD MEASUREMENTS FROM IMPLANT THROUGH FOLLOW-UP**

The following figures present data for leads over the course of the SAMURAI study follow-up:

- Pacing Threshold (Appendix Figure 1 on page 14 and Appendix Figure 2 on page 15)
- Sensed Amplitude (Appendix Figure 3 on page 15 and Appendix Figure 4 on page 16)
- Pacing Impedance (Appendix Figure 5 on page 16 and Appendix Figure 6 on page 17)

There were no significant changes for lead measurements throughout this period, and also no statistical differences between the MRI Group and the Control Group data.

**Pacing Threshold Data**

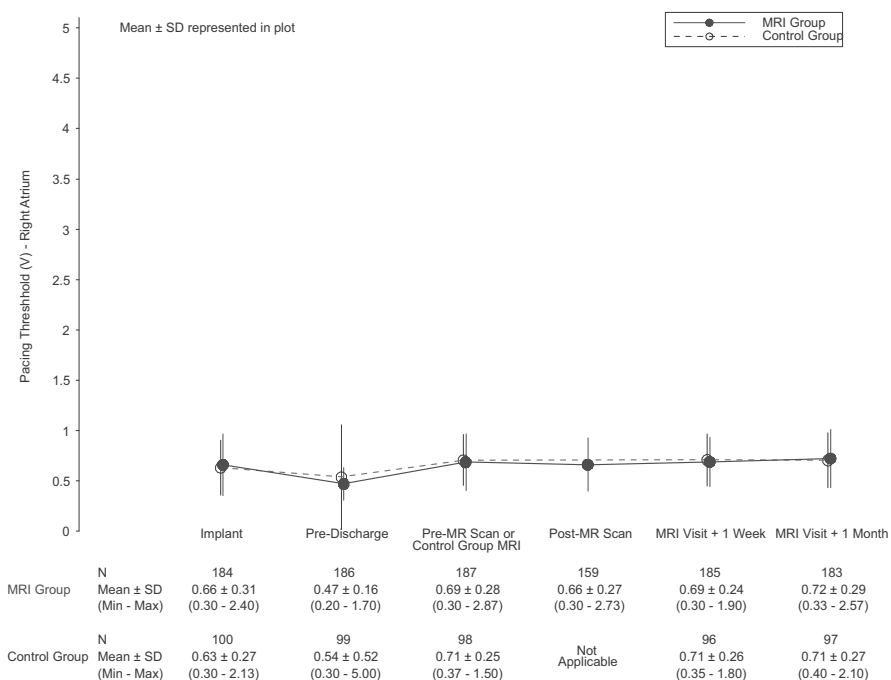

**Appendix Figure 1. RA Pacing Threshold Measurements throughout Follow-up**

APPENDIX 1 Lead Measurements from Implant through Follow-Up

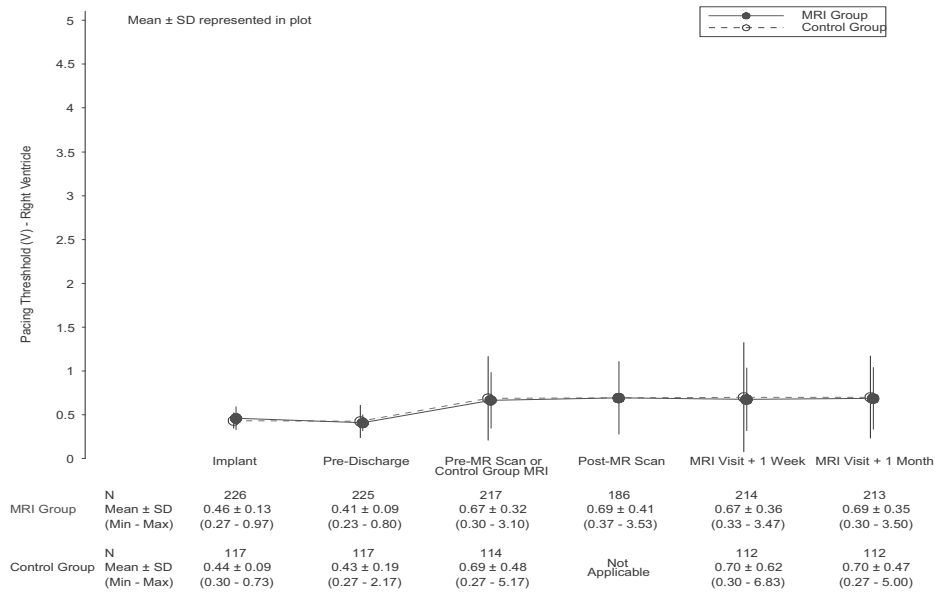

Appendix Figure 2. RV Pacing Threshold Measurements throughout Follow-up

Sensed Amplitude Data

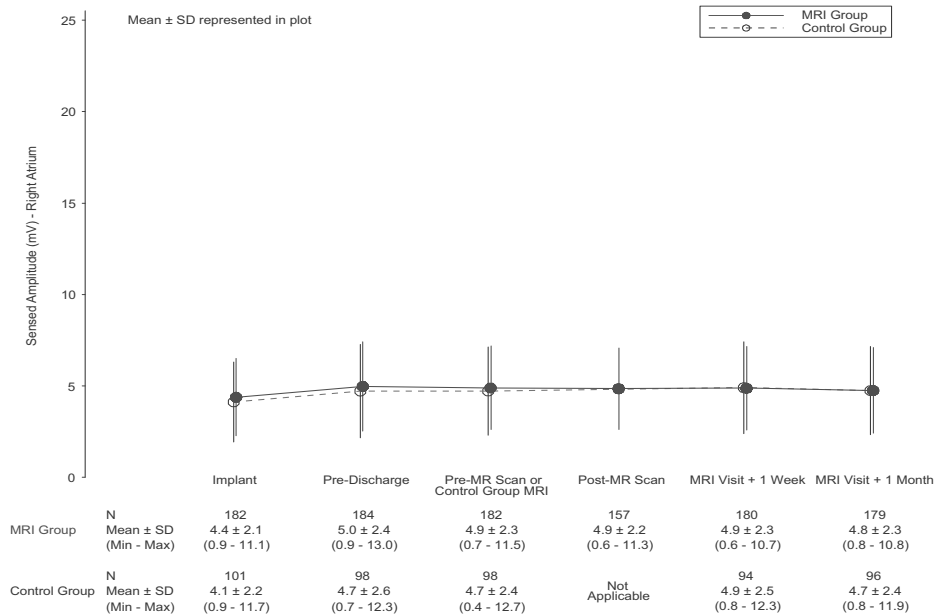

Appendix Figure 3. RA Sensed Amplitude Measurements throughout Follow-up

CLINICAL STUDY - SUMMARY OF SAMURAI STUDY  
**APPENDIX 1 Lead Measurements from Implant through Follow-Up**

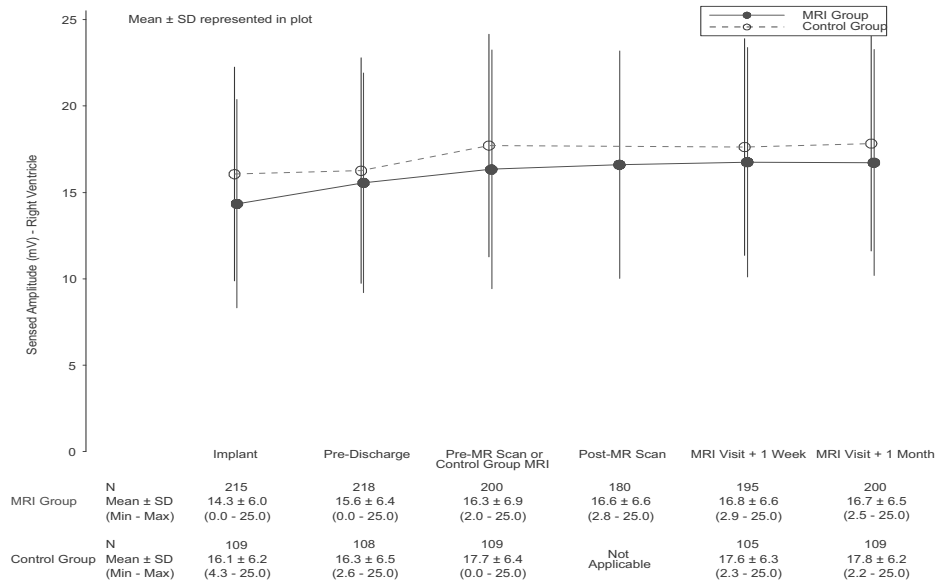

**Appendix Figure 4. RV Sensed Amplitude Measurements throughout Follow-up**

**Pacing Impedance Data**

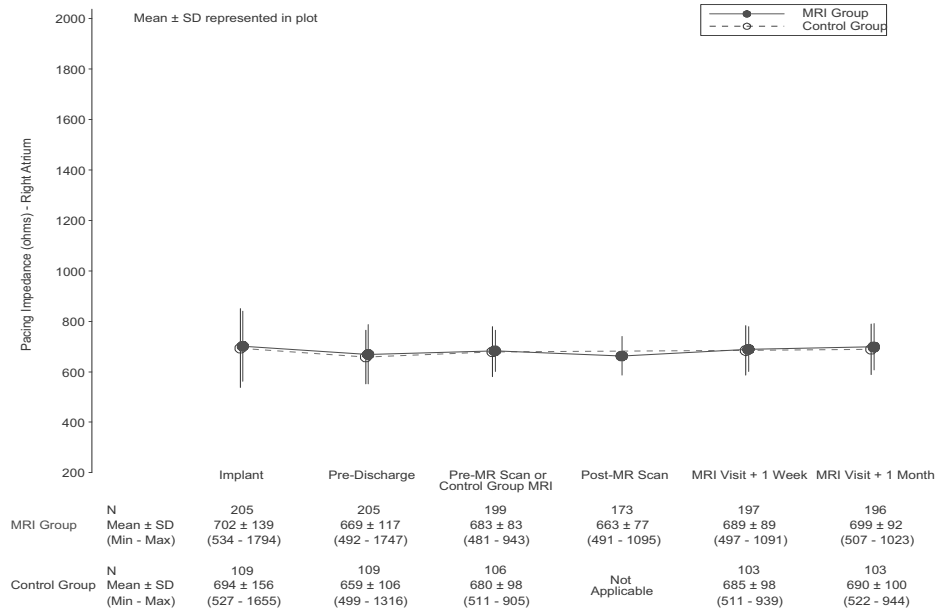

**Appendix Figure 5. RA Pacing Impedance Measurements throughout Follow-up**

APPENDIX 1 Lead Measurements from Implant through Follow-Up

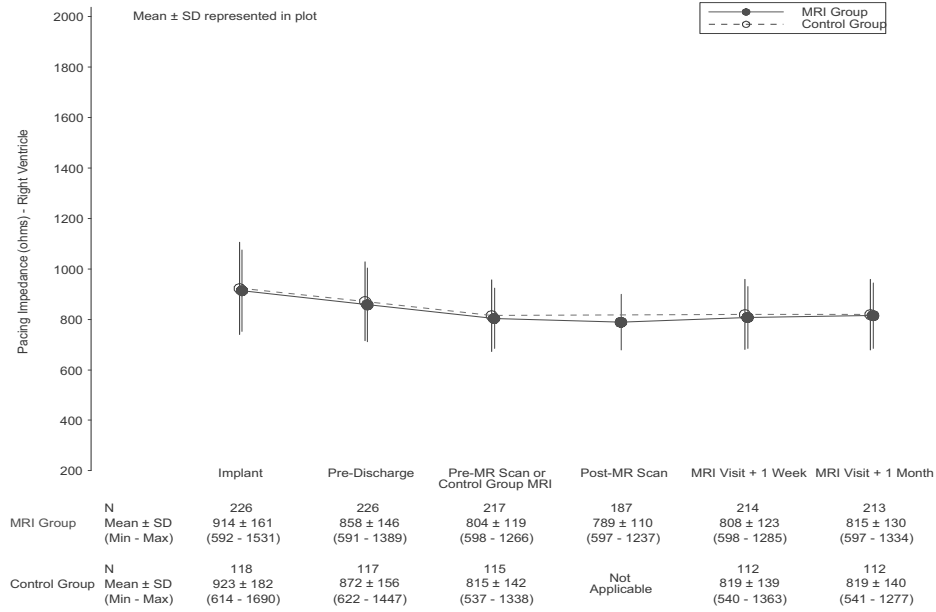

Appendix Figure 6. RV Pacing Impedance Measurements throughout Follow-up

## APPENDIX 2 IMPLANTATION QUESTIONNAIRE

Investigators were asked to evaluate handling of the lead during the implantation procedure. The results of this lead handling questionnaire are provided in Appendix Table 1 on page 18. Overall, implanting physicians were satisfied with the handling of the lead.

**Appendix Table 1. Implant Questionnaire Results (N = 661 Implanted or Attempted Leads)**

Item	Number of Responses (%)				
	RV Active Leads (N=284)	RA Active Leads (N=274)	RV Passive Leads (N=63)	RA Passive Leads (N=40)	All Leads (N=661)
<b>Q1. Rate the radiopacity quality of the extendable/retractable helix markers</b>					
(1) Exceeded Expectations	33 (11.8%)	34 (12.4%)	Not Applicable	Not Applicable	67 (12.1%)
(2) Very Good	135 (48.4%)	132 (48.2%)	Not Applicable	Not Applicable	267 (48.3%)
(3) Good	73 (26.2%)	68 (24.8%)	Not Applicable	Not Applicable	141 (25.5%)
(4) Met Expectations	32 (11.5%)	35 (12.8%)	Not Applicable	Not Applicable	67 (12.1%)
(5) Unacceptable	6 (2.2%)	5 (1.8%)	Not Applicable	Not Applicable	11 (2.0%)
<b>Q2. Rate Handling and Maneuverability of the stylet and lead used</b>					
(1) Exceeded Expectations	57 (20.4%)	55 (20.1%)	12 (19.0%)	7 (17.5%)	131 (20.0%)
(2) Very Good	136 (48.7%)	133 (48.5%)	40 (63.5%)	28 (70.0%)	337 (51.4%)
(3) Good	57 (20.4%)	54 (19.7%)	9 (14.3%)	4 (10.0%)	124 (18.9%)
(4) Met Expectations	29 (10.4%)	30 (10.9%)	2 (3.2%)	1 (2.5%)	62 (9.5%)
(5) Unacceptable	0 (0.0%)	2 (0.7%)	0 (0.0%)	0 (0.0%)	2 (0.3%)
<b>Q3. Rate overall Handling Performance of the Lead</b>					
(1) Exceeded Expectations	72 (25.8%)	66 (24.1%)	11 (17.5%)	7 (17.5%)	156 (23.8%)
(2) Very Good	131 (47.0%)	125 (45.6%)	42 (66.7%)	28 (70.0%)	326 (49.7%)
(3) Good	49 (17.6%)	50 (18.2%)	8 (12.7%)	4 (10.0%)	111 (16.9%)
(4) Met Expectations	27 (9.7%)	28 (10.2%)	2 (3.2%)	1 (2.5%)	58 (8.8%)
(5) Unacceptable	0 (0.0%)	4 (1.5%)	0 (0.0%)	0 (0.0%)	4 (0.6%)
(6) N/A or Rarely Used	0 (0.0%)	1 (0.4%)	0 (0.0%)	0 (0.0%)	1 (0.2%)
<b>Q4. Rate the overall handling and ease of implant using the Pre-formed Atrial J lead</b>					
(1) Exceeded Expectations	Not Applicable	Not Applicable	Not Applicable	6 (15.0%)	6 (15.0%)
(2) Very Good	Not Applicable	Not Applicable	Not Applicable	30 (75.0%)	30 (75.0%)
(3) Good	Not Applicable	Not Applicable	Not Applicable	4 (10.0%)	4 (10.0%)
(4) Met Expectations	Not Applicable	Not Applicable	Not Applicable	0 (0%)	0 (0%)
(5) Unacceptable	Not Applicable	Not Applicable	Not Applicable	0 (0%)	0 (0%)

Boston Scientific Confidential. Unauthorized use is prohibited.

LIT APPROVAL-SAMURAI Clinical Study Summary

Item	Number of Responses (%)				
	RV Active Leads (N=284)	RA Active Leads (N=274)	RV Passive Leads (N=63)	RA Passive Leads (N=40)	All Leads (N=661)
<b>Q5. (Single Chamber) - The Lead is easy to pass through small vessels</b>					
(1) Strongly Agree	12 (4.6%)	Not Applicable	2 (3.5%)	Not Applicable	14 (4.4%)
(2) Agree	12 (4.6%)	Not Applicable	7 (12.3%)	Not Applicable	19 (6.0%)
(3) Somewhat Agree	0 (0%)	Not Applicable	0 (0%)	Not Applicable	0 (0%)
(4) Disagree	0 (0%)	Not Applicable	0 (0%)	Not Applicable	0 (0%)
(5) N/A	237 (90.8%)	Not Applicable	48 (84.2%)	Not Applicable	285 (89.6%)
<b>Q6. (Dual Chamber) - The Lead is easy to pass through small vessels and/or vessels with multiple leads</b>					
(1) Strongly Agree	58 (21.2%)	65 (24.4%)	19 (31.7%)	11 (28.9%)	153 (24.0%)
(2) Agree	155 (56.8%)	161 (60.5%)	33 (55.0%)	27 (71.1%)	376 (59.0%)
(3) Somewhat Agree	10 (3.7%)	10 (3.8%)	0 (0.0%)	0 (0.0%)	20 (3.1%)
(4) Disagree	0 (0.0%)	1 (0.4%)	0 (0.0%)	0 (0.0%)	1 (0.2%)
(5) N/A	50 (18.3%)	29 (10.9%)	8 (13.3%)	0 (0.0%)	87 (13.7%)
<b>Q7. Rate the visibility of the radiopaque suture sleeve on x-ray during and after the implant procedure</b>					
(1) Exceeded Expectations	39 (14.0%)	39 (14.2%)	15 (23.8%)	9 (22.5%)	102 (15.5%)
(2) Very Good	81 (29.0%)	79 (28.8%)	25 (39.7%)	18 (45.0%)	203 (30.9%)
(3) Good	91 (32.6%)	90 (32.8%)	14 (22.2%)	9 (22.5%)	204 (31.1%)
(4) Met Expectations	43 (15.4%)	40 (14.6%)	2 (3.2%)	1 (2.5%)	86 (13.1%)
(5) Unacceptable	4 (1.4%)	4 (1.5%)	0 (0.0%)	0 (0.0%)	8 (1.2%)
(6) N/A or Rarely Used	21 (7.5%)	22 (8.0%)	7 (11.1%)	3 (7.5%)	53 (8.1%)
<b>Q8. The design of the low profile suture sleeve helps minimize bulk in the pocket</b>					
(1) Strongly Agree	48 (17.2%)	45 (16.4%)	14 (22.2%)	10 (25.0%)	117 (17.8%)
(2) Agree	142 (50.9%)	140 (51.1%)	43 (68.3%)	25 (62.5%)	350 (53.4%)
(3) Somewhat Agree	61 (21.9%)	63 (23.0%)	5 (7.9%)	4 (10.0%)	133 (20.3%)
(4) Disagree	22 (7.9%)	22 (8.0%)	0 (0.0%)	1 (2.5%)	45 (6.9%)
(5) N/A	6 (2.2%)	4 (1.5%)	1 (1.6%)	0 (0.0%)	11 (1.7%)

Boston Scientific Confidential. Unauthorized use is prohibited.

**LIT APPROVAL-SAMURAI Clinical Study Summary**



Boston Scientific Confidential. Unauthorized use is prohibited.

**LIT APPROVAL-SAMURAI Clinical Study Summary**

# Boston Scientific

Boston Scientific Corporation  
4100 Hamline Avenue North  
St. Paul, MN 55112-5798 USA

[www.bostonscientific.com](http://www.bostonscientific.com)

1.800.CARDIAC (227.3422)  
+1.651.582.4000

© 2015 Boston Scientific Corporation or its affiliates.  
All Rights Reserved.

358487-024 EN US 2015-10



Boston Scientific Confidential. Unauthorized use is prohibited.

**LIT APPROVAL-SAMURAI Clinical Study Summary**

**Boston  
Scientific**

CLINICAL SUMMARY

# **INGEVITY™ STUDY**

**CAUTION:** Federal law restricts this device to sale by or on the order of a physician trained or experienced in device implant and follow-up procedures.

Boston Scientific Confidential. Unauthorized use is prohibited.

**LIT APPROVAL-INGEVITY Clinical Study Summary**

Boston Scientific Confidential. Unauthorized use is prohibited.

**LIT APPROVAL-INGEVITY Clinical Study Summary**

## TABLE OF CONTENTS

CLINICAL STUDY - SUMMARY OF INGEVITY™ ACTIVE FIXATION AND PASSIVE FIXATION PACE/ SENSE LEAD CLINICAL STUDY.....	1
STUDY DESIGN.....	1
METHODS.....	1
Subject Selection.....	1
Inclusion and Exclusion Criteria.....	1
INGEVITY Study Endpoints.....	2
Safety Endpoints.....	2
Effectiveness Endpoints.....	2
RESULTS.....	3
Subject Demographics.....	3
Study Endpoint Results.....	4
Safety Endpoint Results.....	4
Effectiveness Endpoint Results.....	8
ADVERSE EVENTS SUMMARY.....	10
INGEVITY Study.....	10
Lead-related Safety Data from INGEVITY and SAMURAI Studies.....	10
DEVICE DEFICIENCIES SUMMARY.....	11
DEATH SUMMARY.....	12
CONCLUSIONS.....	13
APPENDIX 1 LEAD MEASUREMENTS FROM IMPLANT THROUGH FOLLOW-UP.....	14
APPENDIX 2 IMPLANTATION QUESTIONNAIRE.....	17

The following are trademarks of Boston Scientific or its affiliates: IMAGEREADY, INGEVITY.

Boston Scientific Confidential. Unauthorized use is prohibited.

**LIT APPROVAL-INGEVITY Clinical Study Summary**

Boston Scientific Confidential. Unauthorized use is prohibited.

**LIT APPROVAL-INGEVITY Clinical Study Summary**

## CLINICAL STUDY - SUMMARY OF INGEVITY™ ACTIVE FIXATION AND PASSIVE FIXATION PACE/SENSE LEAD CLINICAL STUDY

The INGEVITY Active Fixation and Passive Fixation Pace/Sense Lead Clinical Study (hereafter referred to as the INGEVITY study) was designed to collect data to establish the safety, performance, and effectiveness of INGEVITY active fixation and passive fixation pace/sense leads.

### STUDY DESIGN

The INGEVITY study is a prospective, non-randomized, multi-center, global clinical study continuing through 2018. Follow-up visits were scheduled for pre-discharge, 1 month, 3 months, and 12 months post implant, then annually for 5 years post-implant, to study the Safety and Effectiveness Endpoints. This summary includes data collected through the initial 12-month post-implant follow-up period.

### METHODS

#### Subject Selection

The study enrolled patients with approved indications for a pacemaker or cardiac resynchronization therapy-pacemaker (CRT-P) implantable pulse generator who were implanted with an INGEVITY lead(s) and a Boston Scientific pulse generator as their initial (de novo) pacing system implant. Only patients who met all of the inclusion criteria, and none of the exclusion criteria, were enrolled.

#### Inclusion and Exclusion Criteria

##### Inclusion Criteria

- Subject is willing and capable of providing informed consent
- Subject must have the INGEVITY lead(s) and a Boston Scientific pulse generator as their initial (de novo) pacing system implants
- Subject has a Class I or II indication for implantation of a single [VVI(R) only] or dual chamber pacemaker or a CRT-P system according to the American College of Cardiology (ACC)/American Heart Association (AHA)/Hearth Rhythm Society (HRS), or European Society of Cardiology (ESC) guidelines
- Subject is willing and capable of participating in all testing/visits associated with this clinical study at an approved clinical study center and at the intervals defined by this protocol
- Subject is age 18 or above, or of legal age to give informed consent specific to state and national law

##### Exclusion Criteria

- Subject has or has had any pacing or Intra Cardiac Device (ICD) system implants
- Subjects who are intended to receive an AAI(R) pulse generator
- Subject has a known or suspected sensitivity to dexamethasone acetate (DXA)
- Subject has a mechanical tricuspid heart valve
- Subject is enrolled in any other concurrent study, with the exception of local mandatory governmental registries and observational studies/registries that are not in conflict
- Subjects with documented permanent or persistent atrial fibrillation (AF)<sup>1</sup> where the physician intends to implant dual chamber pulse generator [single chamber VVI(R) pulse generators in these subjects is acceptable]
- Subject is currently on the active heart transplant list

1. Calkins H, et al. HRS/EHRA/ECAS expert Consensus Statement on catheter and surgical ablation of atrial fibrillation: recommendations for personnel, policy, procedures and follow-up. *Heart Rhythm* 4:816-861, 2007. [Cited](#).

## 2 | CLINICAL STUDY - SUMMARY OF INGEVITY STUDY METHODS

- Subject has documented life expectancy of less than 12 months
- Women of childbearing potential who are or might be pregnant at the time of study enrollment or INGEVITY lead implant (method of assessment upon physician's discretion)
- Subjects currently requiring dialysis

### INGEVITY Study Endpoints

#### Safety Endpoints

The following endpoints were evaluated to establish safety of the INGEVITY lead.

- Safety Endpoint 1: Lead-related Complication-Free Rate from Implant through Three Months Post-Implant
- Safety Endpoint 2: Lead-related Complication-Free Rate from Three Months Post-Implant through Twelve Months Post-Implant
- Safety Endpoint 3: Hazard of Lead-Related Complications over Time
- Ancillary Safety Endpoint (Long-term Safety evaluated upon study completion): Lead-related Complication-Free Rate from 3 Months through 60 Months Post Implant

Lead-related complications were defined as lead-related adverse events that resulted in death, serious injury, correction using invasive intervention, or permanent loss of device functions. Lead-related adverse events included, but were not limited to, the following based on the AdvaMed Industry Guidance for Uniform Reporting of Clinical Performance of Cardiac Rhythm Management Pulse Generators and Leads, and in accordance with the FDA Guidance:

- Cardiac perforation requiring surgical intervention
- Cardiac perforation not requiring surgical intervention
- Conductor fracture/helix damage
- Lead dislodgement
- Failure to capture
- Oversensing
- Failure to sense (undersensing)
- Insulation breach
- Abnormal pacing impedance
- Extracardiac stimulation

Lead-related complications associated with attempted INGEVITY lead implants counted toward the Safety Endpoints. Lead-related adverse events that were not a complication counted as a complication if intravenous (IV) drug therapy was necessary to treat the event. IV drug therapy that occurred concomitantly but unrelated to the lead-related adverse event did not count as a lead-related complication. Complications involving an INGEVITY lead that occurred as a result of a procedure unrelated to that INGEVITY lead did not count toward this Safety Endpoint.

#### Effectiveness Endpoints

The following endpoints were evaluated to establish effectiveness of the INGEVITY lead. These endpoints were analyzed separately by lead fixation type (active, passive) and chamber (RA, RV).

- Effectiveness Endpoint 1: Pacing Threshold at 0.5 ms pulse width at Three Months Post-Implant
- Effectiveness Endpoint 2: Sensed Amplitude at Three Months Post-Implant
- Effectiveness Endpoint 3: Pacing Impedance at Three Months Post-Implant



## RESULTS

Results included in this INGEVITY study summary were collected through January 6, 2015. Some subjects contributed data for both a right atrial lead and a right ventricular lead. If a follow-up visit was missed, the subject remained eligible to contribute data at subsequent follow-up visits. A summary of the subject disposition is shown in Figure 1 on page 3.

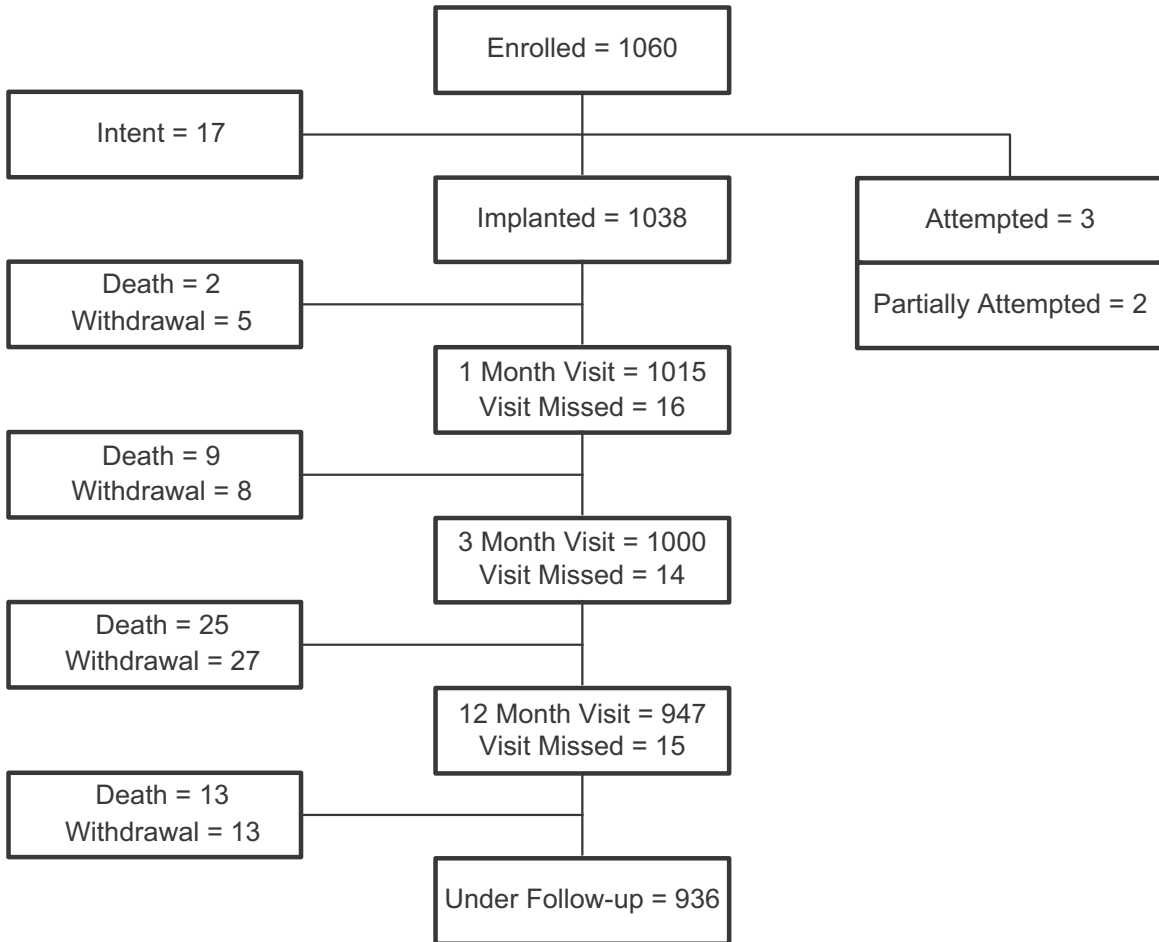

**Figure 1. Subject Disposition**

### Subject Demographics

A total of 1060 subjects were enrolled at 77 centers in the study. See Table 1 on page 4 for a summary of the subject demographics. Overall, the average age of the subjects at implant was  $74.3 \pm 10.6$  years, with an overall gender ratio of 55% males to 45% females. In total, 1270 active fixation and 329 passive fixation leads were implanted or implant was attempted, with 563 leads placed in the right atrium and 1036 leads placed in the right ventricle.

**Table 1. Subject Demographics**

Characteristic	Measurement	All Enrolled Subjects (N=1060)	Implanted or Attempted Subjects	
			Pacemaker (N=1006)	CRT-P (N=35)
Pulse Generator [N (%)]	Single Chamber Pacemaker	176 (17)	176 (17)	0 (0)
	Dual Chamber Pacemaker	830 (78)	830 (83)	0 (0)
	CRT-P	35 (3)	0 (0)	35 (100)
	No Device	19 (2)	0 (0)	0 (0)
Age at Implant (years)	N	1060	1006	35
	Mean ± SD	74.3 ± 10.6	74.3 ± 10.5	74.5 ± 13.4
	Range	23.0 - 98.0	23.0 - 98.0	24.0 - 88.0
Gender [N (%)]	Male	582 (55)	554 (55)	20 (57)
	Female	478 (45)	452 (45)	15 (43)
NYHA Class [N (%)]	I	138 (37)	136 (40)	1 (3)
	II	149 (40)	137 (41)	12 (39)
	III	44 (12)	27 (8)	16 (52)
	IV	3 (1)	1 (0)	2 (6)
	No-HF Subject	39 (10)	36 (11)	0 (0)
LVEF (%)	N	812	765	34
	Mean ± SD	57.4 ± 10.4	58.6 ± 8.9	31.8 ± 10.2
	Range	15.0 - 85.0	20.0 - 85.0	15.0 - 55.0
QRS Duration (ms)	N	957	908	34
	Mean ± SD	111 ± 28	110 ± 28	140 ± 29
	Range	55 - 261	55 - 261	85 - 202
Body Mass Index (kg/m <sup>2</sup> )	N	1052	1000	35
	Mean ± SD	28.5 ± 6.5	28.5 ± 6.4	29.2 ± 5.4
	Range	10.7 - 105.3	10.7 - 105.3	19.4 - 43.9

**Study Endpoint Results**

Safety and Effectiveness Endpoint results are summarized below.

**Safety Endpoint Results**

A summary of the Safety Endpoints results is shown in the Table 2 on page 5, with details provided in the following sections.

**Table 2. Summary of Safety Endpoints Results**

Safety Endpoint	Measurement	Performance Goal	Result (Confidence Limit)	Conclusion
1	0-3 month Lead-related Complication Free Rate	> 91.4%	98.4% (95% One-Sided Lower Confidence Limit = 97.7%)	Endpoint Met
2	3-12 month Lead-related Complication Free Rate	> 94%	99.7% (95% One-Sided Lower Confidence Limit = 99.4%)	Endpoint Met
3	0-12+ month Lead Hazard Stability (Weibull shape parameter*)	< 1	0.22 (95% One-Sided Upper Confidence Limit = 0.29)	Endpoint Met

\* A shape parameter < 1 obtained from a Weibull survival model describes a lead with a decelerating hazard of lead-related complications over time.

**Safety Endpoint 1: Lead-related Complication-free Rate from Implant through Three Months Post-implant.**

Safety of the INGEVITY lead was first evaluated by the lead-related complication-free rate (CFR) from lead implant through the three month post implant follow-ups, with a performance goal of > 91.4%. The CFR from 0 through 3 months for all INGEVITY leads was 98.4%, with a one-sided 95% lower confidence limit of 97.7% (see Figure 2 on page 5 and Table 3 on page 5).

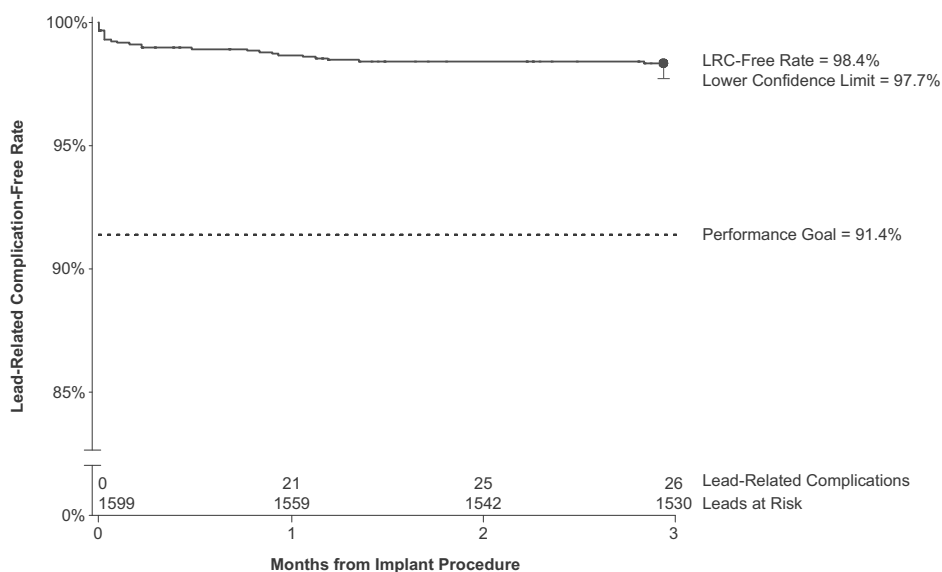

**Figure 2. Safety Endpoint 1 Complication-free Rate from 0-3 months post-implant. Results for all leads.**

The results were further analyzed by lead fixation type and heart chamber (see Table 3 on page 5).

**Table 3. Safety Endpoint 1 Complication-free Rate from 0-3 months post-implant. Results for all groups of leads.**

Group	N	Lead-Related Complication Free Rate 0-3 months	95% One-Sided Lower Confidence Limit
All Leads	1599	98.4%	97.7%
- RV Active Fixation	828	98.5%	97.7%

6 | CLINICAL STUDY - SUMMARY OF INGEVITY STUDY  
**RESULTS**

Group	N	Lead-Related Complication Free Rate 0-3 months	95% One-Sided Lower Confidence Limit
- RA Active Fixation	442	98.4%	97.0%
- RA/RV Passive Fixation	329	97.9%	96.1%

Since the lower confidence limit was greater than the performance goal of 91.4% for all groups, the data support the safety of the INGEVITY lead through the 3 month post-implant period.

**Safety Endpoint 2: Lead-related Complication-free Rate from Three Months Post-implant through Twelve Months Post-implant.**

Safety of the INGEVITY lead was next evaluated by the lead-related complication-free rate (CFR) from 3 months post-implant through 12 months post-implant, with a performance goal of > 94%. The CFR from 3 through 12 months for all INGEVITY leads was 99.7%, with a one-sided 95% lower confidence limit of 99.4% (see Figure 3 on page 6 and Table 4 on page 6).

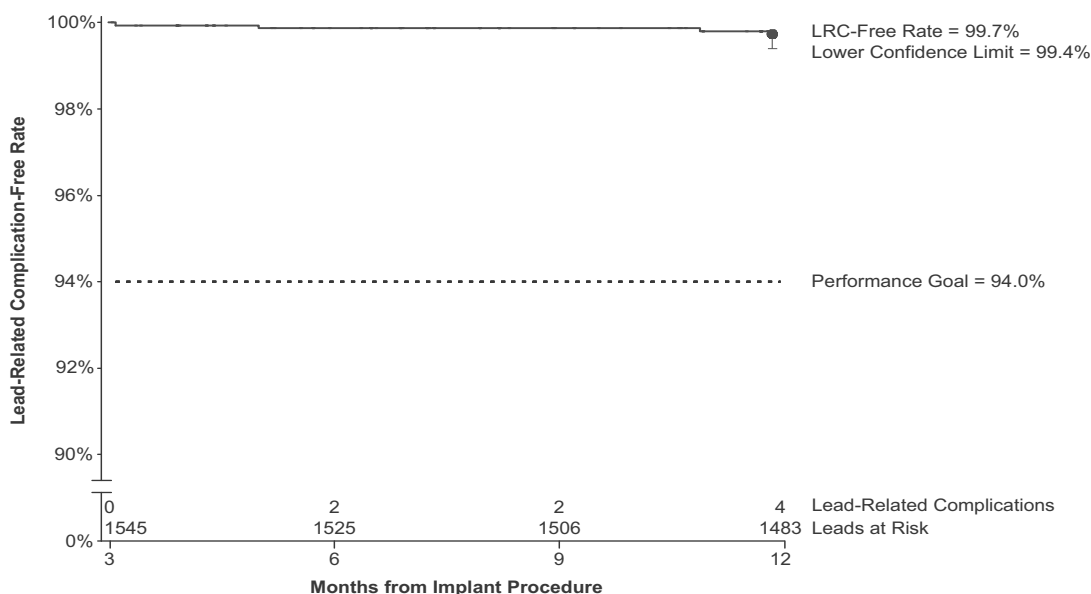

**Figure 3. Safety Endpoint 2 Complication-free Rate from 3-12 months post-implant. Results for all leads.**

The results were further analyzed by lead fixation type and heart chamber (see Table 4 on page 6).

**Table 4. Safety Endpoint 2 Complication-free Rate from 3-12 months post-implant. Results for all groups of leads.**

Group	N	Lead-Related Complication Free Rate 3-12 months	95% One-Sided Lower Confidence Limit
All Leads	1545	99.7%	99.4%
- RV Active Fixation	804	99.5%	98.8%
- RA Active Fixation	424	100.0%	100.0%
- RA/RV Passive Fixation	317	100.0%	100.0%

Since the lower confidence limit was greater than the performance goal of 94% for all groups, the data support the safety of the INGEVITY lead through the 12 month post-implant period.

**Safety Endpoint 3: Hazard of Lead-related Complications over Time**

The hazard of lead-related complications over time was analyzed by Weibull regression analysis of all Safety Endpoint data collected through 12 months post-implant. The exact follow-up time in the post-implant period for each lead was included in the analysis. A Weibull shape greater than one (>1), equal to one (=1) and less than one (<1) indicated accelerating, constant, and decelerating hazard over time, respectively.

A Weibull shape parameter of 0.22 derived from analysis of lead-related complications over the 12 month post-implant period indicated a decelerating hazard rate over time (see Figure 4 on page 7). The figure presents the smooth modeled Weibull hazard resulting from the Weibull regression analysis overlaid on top of the raw observed lead-related complication hazard data. The corresponding one-sided 95% upper confidence limit was 0.29.

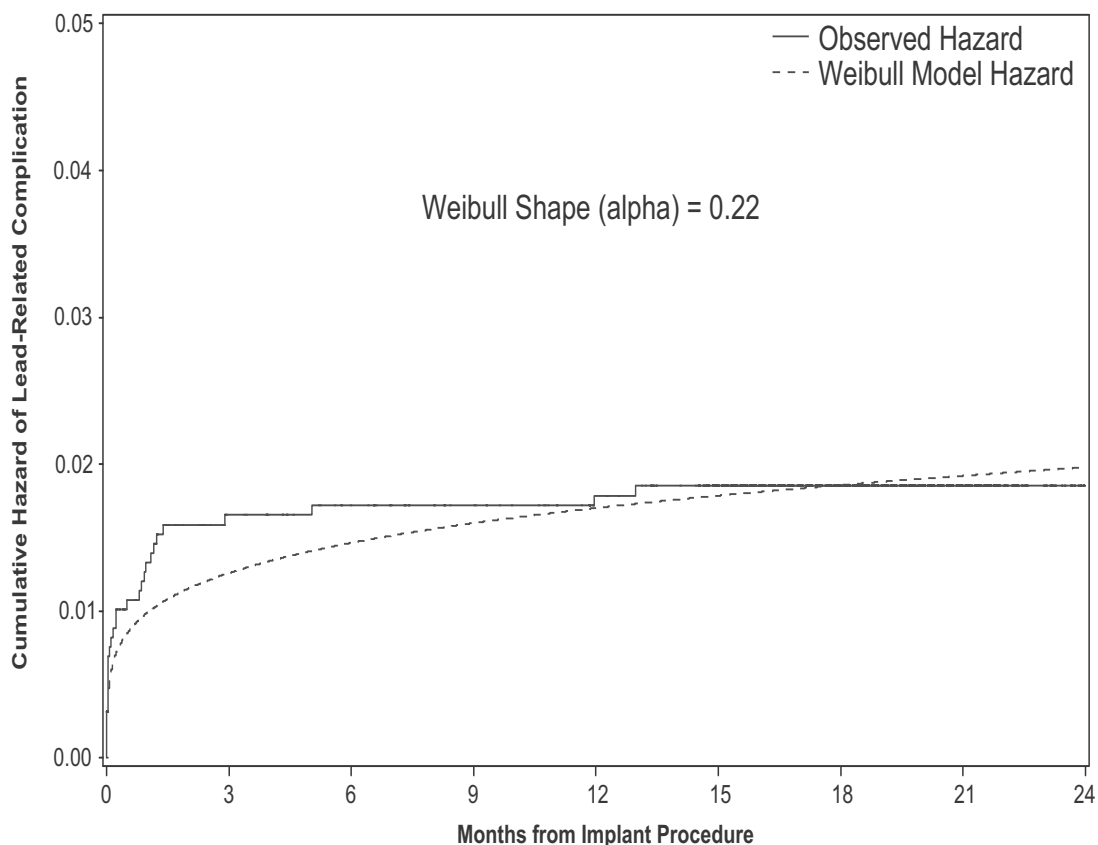

**Figure 4. Safety Endpoint 3 Hazard of Lead-related Complications over Time. Results for all leads.**

The results were further analyzed by lead fixation type and heart chamber (see Table 5 on page 7).

**Table 5. Safety Endpoint 3 Hazard of Lead-related Complications over Time. Results for all groups of leads.**

Group	Weibull Shape Parameter (Alpha)	95% One-Sided Upper Confidence Limit
All Leads	0.22	0.29
- RV Active Fixation	0.24	0.36
- RA Active Fixation	0.26	0.48

Boston Scientific Confidential. Unauthorized use is prohibited.

Group	Weibull Shape Parameter (Alpha)	95% One-Sided Upper Confidence Limit
- RA/RV Passive Fixation	0.16	0.30

Since the hazard of lead-related complications decelerated over the course of the follow-up period, the data support the safety of the INGEVITY lead.

**Effectiveness Endpoint Results**

A summary of the Effectiveness Endpoints results is shown in the table below (Table 6 on page 8), with details, including results for lead fixation type and heart chamber, provided in the following sections.

**Table 6. Summary of Effectiveness Endpoints Results**

Effectiveness Endpoint	Measurement	Performance Goal	Result ± SD (Confidence Limit)	Conclusion
1	3 month Pacing Threshold	< 1.5 V	0.67 V ± 0.33 V (Upper One-sided 95% Confidence limit = 0.69)	Endpoint Met
2	RA 3 month Sensed Amplitude	> 1.5 mV	4.8 mV ± 2.6 mV (Lower One-sided 95% Confidence limit = 4.6)	RA Endpoint Met
	RV 3 month Sensed Amplitude	> 5.0 mV	16.5 mV ± 6.5 mV (Lower One-sided 95% Confidence limit = 16.2)	RV Endpoint Met
3	3 month Pacing Impedance	300 - 1300 Ω	773 Ω ± 155 Ω (90% Confidence Interval = 766, 779)	Endpoint Met

**Effectiveness Endpoint 1: Pacing Threshold at 0.5 ms Pulse Width at Three Months Post-implant**

The first aspect of effectiveness of the INGEVITY lead was determined by evaluation of bipolar pacing thresholds at a 0.5 ms pulse width at 3 months post-implant. Only leads with a measurement taken at the 3 month follow-up were included in the analysis.

The mean pacing threshold for a total of 1482 threshold measurements collected at the 3 month follow-up was 0.67 V with an upper one-sided 95% confidence limit of 0.69 V, resulting in a p-value < 0.001 (see Table 7 on page 8). A total of 98.5% of threshold measurements were at or below the performance goal value of 1.5 V.

The results were further analyzed by lead fixation type (active, passive) and chamber (RA, RV) (see Table 7 on page 8).

**Table 7. Effectiveness Endpoint 1 Pacing Threshold at 0.5 ms pulse width at 3 months post-implant. Results for all groups of leads.**

Group	N	Mean Pacing Threshold V ± SD	Upper One-sided 95% Confidence Limit
All Leads	1482	0.67 ± 0.33	0.69
- RV Active Fixation	782	0.68 ± 0.33	0.69
- RA Active Fixation	394	0.75 ± 0.39	0.78
- RA/RV Passive Fixation	306	0.57 ± 0.19	0.59

Since for all cases the mean pacing threshold obtained at 3 months post-implant was significantly lower than the performance goal, the data from analysis of all leads, and from analyses of lead fixation type and chamber, support the effectiveness of the INGEVITY lead at 3 months post-implant.

**Effectiveness Endpoint 2: Sensed Amplitude at Three Months Post-implant**

The second aspect of effectiveness of the INGEVITY lead was determined by examination of sensed amplitudes at 3 months post-implant. Analysis was performed separately for each heart chamber. Leads that did not have P- or R-wave sensed amplitude data collected at the 3 month follow-up were not included in the analysis of P- and R-waves, respectively.

A total of 1435 sensed amplitude measurements (521 in the right atrium and 914 in the right ventricle) were taken at the 3 month follow-up visit and included in the endpoint analysis. The mean sensed amplitude in the right atrium was 4.8 mV with a lower one-sided 95% confidence limit of 4.6 mV, resulting in a p-value < 0.001 (see Table 8 on page 9). The mean sensed amplitude in the right ventricle was 16.5 mV with a lower one-sided 95% confidence limit of 16.2 mV, resulting in a p-value < 0.001 (see Table 8 on page 9). A total of 91.6 % of measurements in the atrium and 96.4 % of measurements in the ventricle were at or above the performance goals of 1.5 mV and 5.0 mV, respectively.

**Table 8. Effectiveness Endpoint 2 Sensed Amplitude at 3 months post-implant. Results for all groups of leads.**

Group	N	Mean Sensed Amplitude mV ± SD	Lower One-sided 95% Confidence Limit
All Right Atrial Leads	521	4.8 ± 2.6	4.6
- RA Active fixation	409	4.8 ± 2.7	4.6
- RA Passive fixation	112	4.7 ± 2.5	4.3
All Right Ventricular Leads	914	16.5 ± 6.5	16.2
- RV Active fixation	738	16.7 ± 6.5	16.3
- RV Passive fixation	176	16.0 ± 6.5	15.2

Since the mean sensed amplitude obtained in both the right atrium and the right ventricle at 3 months post-implant was significantly greater than the respective performance goals, these data also support the effectiveness of the INGEVITY lead at 3 months post-implant.

**Effectiveness Endpoint 3: Pacing Impedance at Three Months Post-implant**

The third aspect of effectiveness of the INGEVITY lead was determined by analysis of pacing impedance at 3 months post-implant. Leads that did not have pacing impedance values collected at 3 months post-implant were not included in this analysis.

A total of 1526 pacing impedance measurements were taken at the 3 month follow-up visit and included in the endpoint analysis. The mean pacing impedance was 773 Ω with a confidence interval of 776 to 779 Ω, between the performance goals of 300 and 1300 Ω, resulting in a p-value < 0.001 (see Table 9 on page 9). A total of 98.6% of measurements were observed to be between the performance goals of 300 and 1300 Ω. The results were further analyzed by lead fixation type (active, passive) and chamber (RA, RV) (see Table 9 on page 9).

**Table 9. Effectiveness Endpoint 3 Pacing Impedance at 3 Months Post-implant. Results for all groups of leads.**

Group	N	Mean Pacing Impedance Ω ± SD	90% Confidence Interval
All Leads	1526	773 ± 155	(766, 779)
- RV Active Fixation	795	824 ± 158	(815, 834)
- RA Active Fixation	420	711 ± 139	(700, 722)
- RA/RV Passive Fixation	311	724 ± 116	(713, 734)

The overall mean pacing impedance obtained at 3 months post-implant for all groups of leads was within the performance goal range, and supports the effectiveness of the INGEVITY lead at 3 months post-implant.

Boston Scientific Confidential. Unauthorized use is prohibited.

**ADVERSE EVENTS SUMMARY**

**INGEVITY Study**

As of January 6, 2015, of the 1041 implanted or attempted subjects, 92.1% were free from adverse events related to the implant procedure, and 95.7% and 97.9% were free from adverse events related to the INGEVITY RA and RV leads, respectively. A summary of Adverse Events by Complication and Observation is shown in Table 10 on page 10. A complication was defined as an adverse event that resulted in death, serious injury, correction using invasive intervention, or permanent loss of device functions.

**Table 10. Adverse Events Summary**

Relationship	Total		Classification			
			Complication		Observation	
	Events	Subjects (%)	Events	Subjects (%)	Events	Subjects (%)
Total (N at risk = 1041)	2199	675 (64.8%)	667	359 (34.5%)	1515	570 (54.8%)
PG (N at risk = 1041)	29	27 (2.6%)	5	5 (0.5%)	24	22 (2.1%)
RA Lead - INGEVITY-related (N at risk = 564)	26	24 (4.3%)	12	12 (2.1%)	14	12 (2.1%)
RA Lead - Other (N at risk = 858)	14	13 (1.5%)	10	10 (1.2%)	4	4 (0.5%)
RV Lead - INGEVITY-related (N at risk = 1041)	29	22 (2.1%)	22	15 (1.4%)	7	7 (0.7%)
RV Lead - Other (N at risk = 1041)	1	1 (0.1%)	1	1 (0.1%)	0	0 (0.0%)
LV Lead (N at risk = 41)	8	7 (17.1%)	1	1 (2.4%)	7	6 (14.6%)
Procedure (N at risk = 1041)	93	82 (7.9%)	29	28 (2.7%)	64	57 (5.5%)
Cardiovascular - HF (N at risk = 1041)	151	98 (9.4%)	80	58 (5.6%)	70	60 (5.8%)
Cardiovascular - Non-HF (N at risk = 1041)	716	421 (40.4%)	132	110 (10.6%)	584	367 (35.3%)
Non-cardiovascular (N at risk = 1041)	1000	418 (40.2%)	357	218 (20.9%)	643	324 (31.1%)
Other (N at risk = 1041)	116	98 (9.4%)	18	18 (1.7%)	98	82 (7.9%)
Unclassified (N at risk = 1041)	16	9 (0.9%)	0	0 (0.0%)	0	0 (0.0%)

**Lead-related Safety Data from INGEVITY and SAMURAI Studies**

Additional data applicable to the INGEVITY lead were collected from another Boston Scientific clinical study, the SAMURAI Clinical study, which was designed to confirm the safety, performance, and effectiveness of the ImageReady™ MR Conditional Pacing System (hereafter referred to as the ImageReady System). INGEVITY MRI pace/sense leads are a component of the ImageReady System, and are identical in design to INGEVITY pace/sense leads, with the exception of the product-specific markings. Therefore, lead-related safety data collected in the SAMURAI study are applicable to INGEVITY pace/sense leads.

The table below (Table 11 on page 11) is a summary of comparable safety data across the two studies. Data are presented as the “number of leads with events/total number of leads eligible for safety analysis (%)

Boston Scientific Confidential. Unauthorized use is prohibited.

**LIT APPROVAL-INGEVITY Clinical Study Summary**



of total)". The median follow-up time for the INGEVITY study was 18 months, and the median follow-up time for the SAMURAI study was 10 months.

**Table 11. Summary of Safety Data for the INGEVITY study and the SAMURAI study**

Adverse Event	Leads Included	INGEVITY	SAMURAI	Total of both
Lead-Related Adverse Event	All Leads	60/1599 (3.75%)	33/665 (4.96%)	93/2264 (4.11%)
- Lead-Related Complication	All Leads	29/1599 (1.81%)	19/665 (2.86%)	48/2264 (2.12%)
Dislodgement	All Leads	20/1599 (1.25%)	7/665 (1.05%)	27/2264 (1.19%)
Perforation/Pericardial Effusion	Active Fixation Leads	4/1270 (0.31%)	7/563 (1.24%)	11/1833 (0.60%)
- Perforation	Active Fixation Leads	0/1270 (0.00%)	7/563 (1.24%)	7/1833 (0.38%)
- Pericardial Effusion	Active Fixation Leads	4/1270 (0.31%)	0/563 (0.00%)	4/1833 (0.22%)
Conductor Coil Fracture	All Leads	1*/1599 (0.06%)	0/665 (0.00%)	1/2264 (0.04%)

\*One conductor coil fracture occurred in the INGEVITY study, and was classified as a ventricular lead fracture at the costoclavicular junction, consistent with subclavian crush.

Note: The leads eligible for safety analysis include a maximum of one lead per subject per chamber.

Similar lead-related adverse events results were obtained in both the INGEVITY study and the SAMURAI study. Therefore, the data from the SAMURAI study further support the safety of the INGEVITY lead.

## DEVICE DEFICIENCIES SUMMARY

The INGEVITY study and the SAMURAI study each collected device deficiencies. Per ISO 14155, a device deficiency was defined as any inadequacy of a medical device with respect to its identity, quality, durability, reliability, safety or performance. Device deficiencies include malfunctions, misuse or use errors, and inadequate labeling. Per ISO 14155, device deficiencies and adverse events have unique definitions. Therefore, device deficiencies were separately reported from adverse events (see adverse events definition in "Safety Endpoints" on page 2).

Table 12 on page 12 is a summary of device deficiencies reported in the INGEVITY study, the SAMURAI study, and the two studies combined. Data are presented as the "number of leads with deficiencies/total number of leads implanted and attempted (% of total)". The rate of occurrence of device deficiencies across both studies was 6.4%. Some examples of device deficiencies include poor visibility of suture sleeve, inability to place the lead, and difficulty with helix extension/retraction. The most common device deficiency observed was difficulty with helix extension/retraction, 3.9% for the INGEVITY study, 6.8% for the SAMURAI study, and 4.8% across both studies.

Some of these helix extension/retraction device deficiencies resulted in lead conductor coil breaks, which were consistent with acute overload and not flex fatigue fracture. The rate of occurrence of lead conductor coil breaks was 1.6% for the INGEVITY study, 3.3% for the SAMURAI study, and 2.1% across both studies. In each case of conductor coil break, inadequate functionality of the lead was identified prior to pocket closure and the lead was removed from service. The leads were subsequently determined to have broken coils based on return product analysis.

Analysis of study data did not show an elevated safety risk of death, adverse events, serious adverse events, or complication for subjects with a helix extension/retraction device deficiency or a lead conductor coil break when compared to those who did not experience a helix extension/retraction device deficiency or lead conductor coil break.

Boston Scientific Confidential. Unauthorized use is prohibited.

LIT APPROVAL-INGEVITY Clinical Study Summary

## 12 | CLINICAL STUDY - SUMMARY OF INGEVITY STUDY DEATH SUMMARY

To mitigate the extension/retraction device deficiencies, manufacturing improvements were made and the instructions for use were clarified. For marketed INGEVITY lead performance data including occurrence of conductor coil breaks, see the Boston Scientific Rhythm Management Product Performance Report at [www.bostonscientific.com/ppr](http://www.bostonscientific.com/ppr).

**Table 12. Summary of Device Deficiencies for the INGEVITY study and the SAMURAI study**

Device Deficiency	Leads Included	INGEVITY	SAMURAI	Total of both
All Reported	All	98/1656 (5.9%)	54/705 (7.7%)	152/2361 (6.4%)
- Active Fixation	Active Fixation	91/1322 (6.9%)	54/601 (9.0%)	145/1923 (7.5%)
- Passive Fixation	Passive Fixation	7/334 (2.1%)	0/104 (0.0%)	7/438 (1.6%)
Helix Extension/ Retraction	Active Fixation	52/1322 (3.9%)	41/601 (6.8%)	93/1923 (4.8%)
- Right Atrium	RA Active Fixation	36/475 (7.6%)	23/299 (7.7%)	59/774 (7.6%)
- Right Ventricle	RV Active Fixation	16/847 (1.9%)	18/302 (6.0%)	34/1149 (3.0%)
Coil Breaks*	Active Fixation	21/1322 (1.6%)	20/601 (3.3%)	41/1923 (2.1%)
- Right Atrium	RA Active Fixation	14/475 (2.9%)	11/299 (3.7%)	25/774 (3.2%)
- Right Ventricle	RV Active Fixation	7/847 (0.8%)	9/302 (3.0%)	16/1149 (1.4%)

\*Coil Breaks are a subset of Helix Extension/Retraction device deficiencies.

Note: All implanted and attempted leads are included.

## DEATH SUMMARY

Table 13 on page 12 provides an overview of the 49 subject deaths (4.6% of implanted subjects) that occurred during the INGEVITY study. Classification of the deaths was provided by the independent Clinical Events Committee (CEC). The five "Unclassified" deaths are pending classification, upon review of further source information.

**Table 13. Summary of Study Deaths (N = 1060 Enrolled Subjects)**

Primary Organ Cause	Number (%) of Subjects	% of total deaths	
		Yes	Unknown
Non Cardiac	22 (2.1%)	0 (0%)	0 (0%)
Cardiac: Pump Failure	3 (0.3%)	0 (0%)	0 (0%)
Cardiac: Unknown	1 (0.1%)	0 (0%)	0 (0%)
Cardiac: Ischemic	1 (0.1%)	0 (0%)	0 (0%)
Unknown	17 (1.6%)	0 (0%)	6 (0.6%)
Unclassified	5 (0.5%)	Not applicable	Not applicable

The CEC did not attribute any deaths to be related to the INGEVITY lead. Due to insufficient source information on some deaths, the CEC was unable to classify the relationship of the death to the INGEVITY lead in six of the seventeen deaths where the primary organ cause was unknown.

## CONCLUSIONS

The results from this clinical study performed with INGEVITY active fixation and passive fixation pace/sense leads indicate that all Safety Endpoints and all Effectiveness Endpoints were met. The Safety Endpoints analyzed the lead-related complications-free rate through the post-implant follow-up period included in this summary, and, therefore, demonstrate safety for long-term implant. Effective performance of the lead was exhibited by evaluation of pacing thresholds, sensed amplitude, and pacing impedance through 3 months of follow-up post-implant. The results indicate clinically acceptable values for all categories. In conclusion, this clinical study demonstrated the safety and effectiveness of INGEVITY active fixation and passive fixation pace/sense leads.

**APPENDIX 1 LEAD MEASUREMENTS FROM IMPLANT THROUGH FOLLOW-UP**

The following figures present pacing threshold, sensed amplitude and pacing impedance data for INGEVITY leads over the course of follow-up. Refer to Appendix Figure 1 on page 14, Appendix Figure 2 on page 15, and Appendix Figure 3 on page 16.

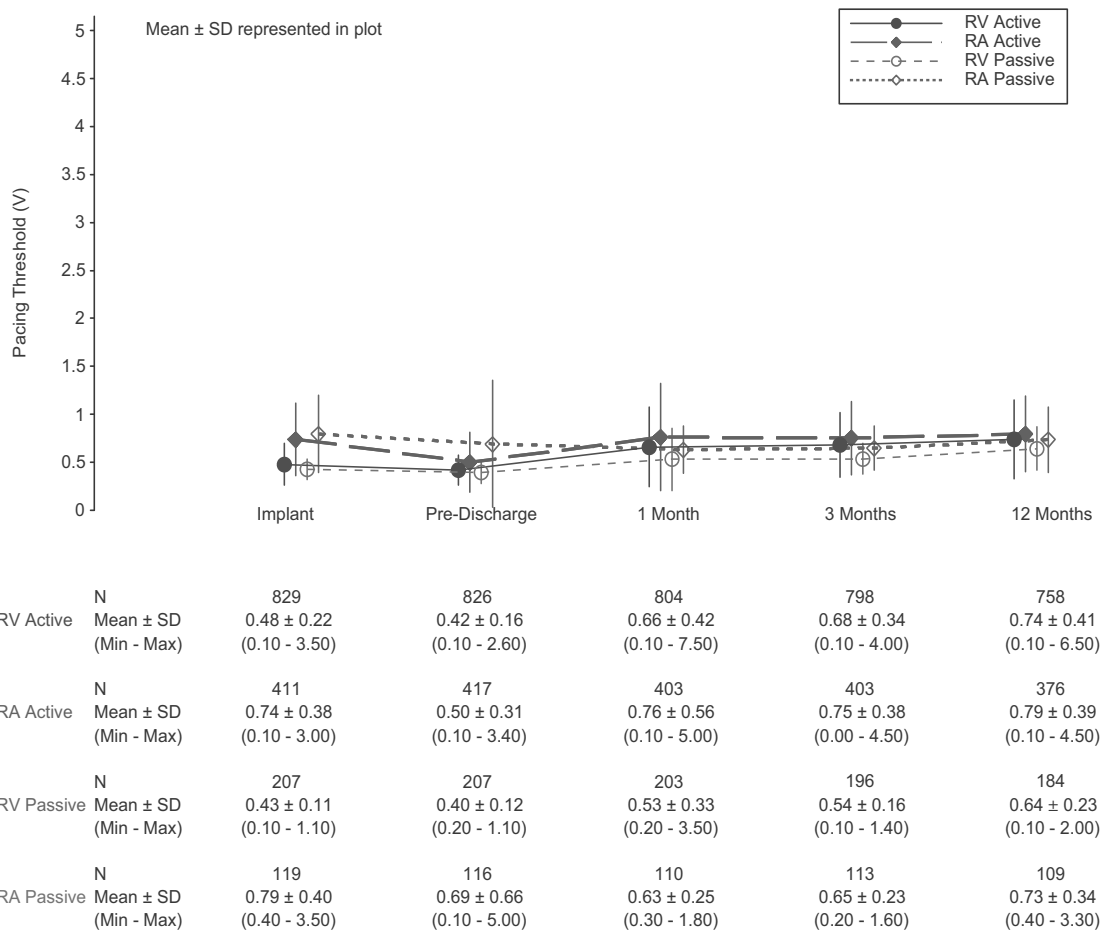

**Appendix Figure 1. INGEVITY Pacing Threshold Measurements throughout Follow-Up**

APPENDIX 1 Lead Measurements from Implant through Follow-Up

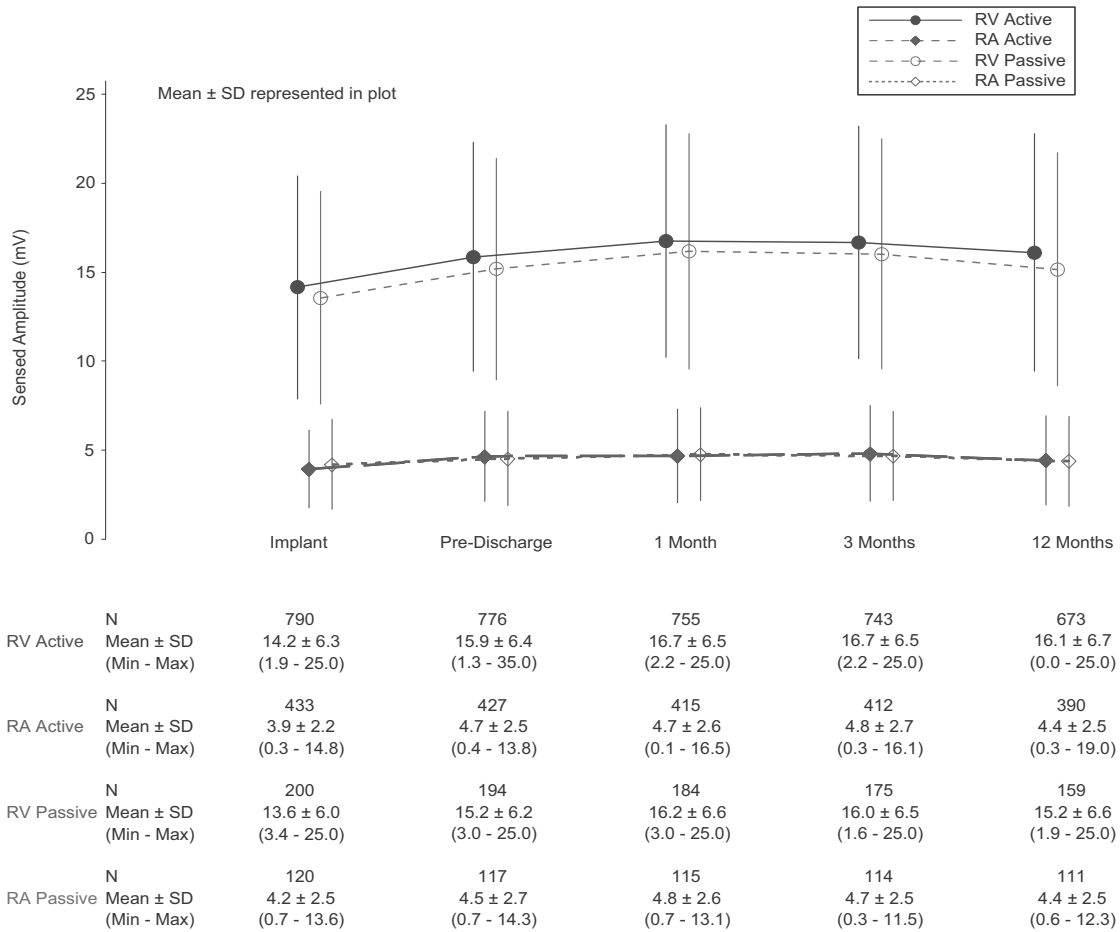

Appendix Figure 2. INGEVITY Sensed Amplitude Measurements throughout Follow-Up

**APPENDIX 1 Lead Measurements from Implant through Follow-Up**

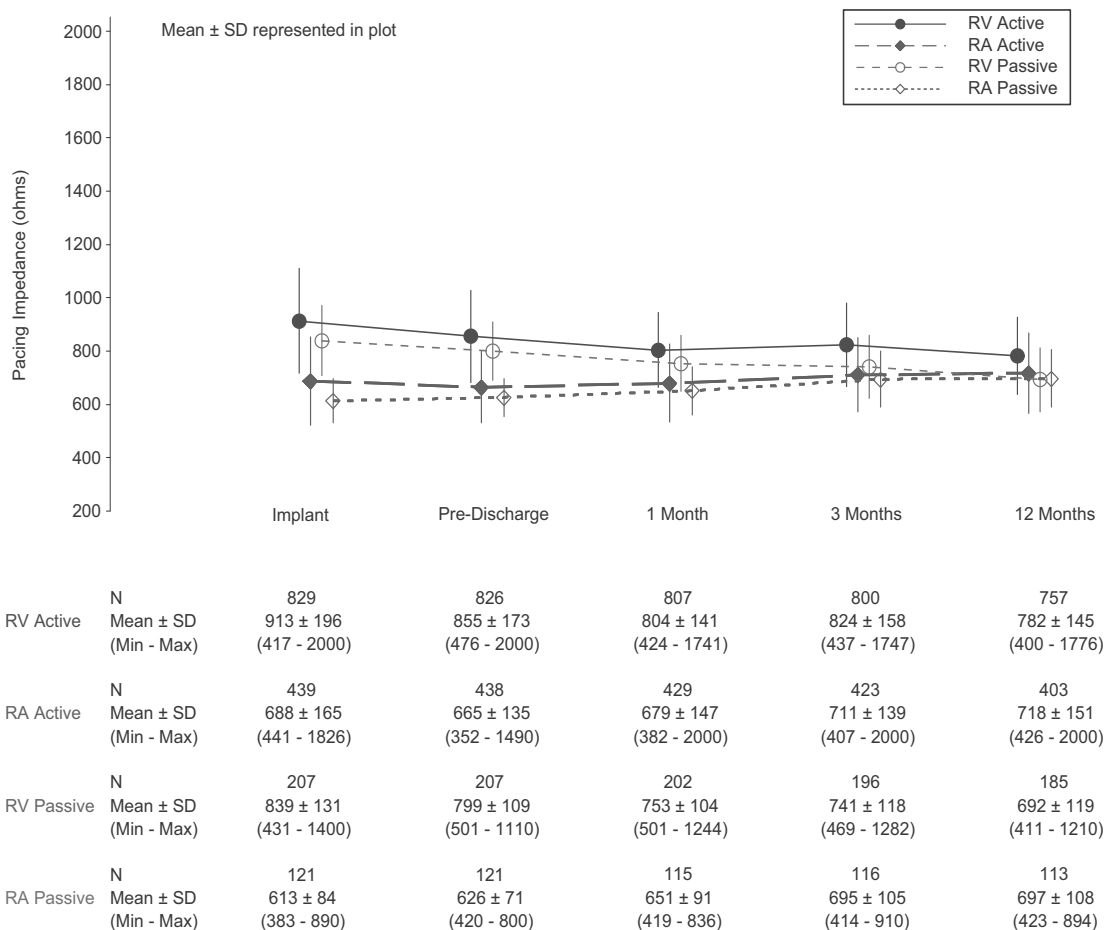

**Appendix Figure 3. INGEVITY Pacing Impedance Measurements throughout Follow-Up**

## APPENDIX 2 IMPLANTATION QUESTIONNAIRE

Investigators were asked to evaluate handling of the lead during the implantation procedure. The results of this lead handling questionnaire are provided in Appendix Table 1 on page 17. Overall, implanting physicians were satisfied with handling of the lead.

**Appendix Table 1. Implant Questionnaire Results (N = 1653 Implanted or Attempted Leads)**

Item	Number of Responses (%)				
	RV Active Leads (N=844)	RA Active Leads (N=475)	RV Passive Leads (N=213)	RA Passive Leads (N=121)	All Leads (N=1653)
<b>Q1. Rate the radiopacity quality of the extendable/retractable helix markers</b>					
(1) Exceeded Expectations	136 (16.6%)	41 (9.4%)	Not applicable	Not applicable	177 (14.1%)
(2) Very Good	408 (49.7%)	222 (50.7%)	Not applicable	Not applicable	630 (50.0%)
(3) Good	164 (20.0%)	94 (21.5%)	Not applicable	Not applicable	258 (20.5%)
(4) Met Expectations	104 (12.7%)	74 (16.9%)	Not applicable	Not applicable	178 (14.1%)
(5) Unacceptable	9 (1.1%)	7 (1.6%)	Not applicable	Not applicable	16 (1.3%)
<b>Q2. Rate Handling and Maneuverability of the stylet and lead used</b>					
(1) Exceeded Expectations	177 (21.4%)	69 (15.7%)	25 (11.8%)	22 (18.3%)	293 (18.3%)
(2) Very Good	459 (55.5%)	260 (59.2%)	122 (57.8%)	58 (48.3%)	899 (56.3%)
(3) Good	148 (17.9%)	81 (18.5%)	44 (20.9%)	25 (20.8%)	298 (18.7%)
(4) Met Expectations	41 (5.0%)	28 (6.4%)	19 (9.0%)	14 (11.7%)	102 (6.4%)
(5) Unacceptable	2 (0.2%)	1 (0.2%)	1 (0.5%)	1 (0.8%)	5 (0.3%)
<b>Q3. Rate overall Handling Performance of the Lead</b>					
(1) Exceeded Expectations	197 (23.8%)	75 (17.1%)	22 (10.5%)	17 (14.2%)	311 (19.5%)
(2) Very Good	441 (53.4%)	253 (57.6%)	122 (58.4%)	65 (54.2%)	881 (55.3%)
(3) Good	147 (17.8%)	81 (18.5%)	49 (23.4%)	27 (22.5%)	304 (19.1%)
(4) Met Expectations	37 (4.5%)	25 (5.7%)	15 (7.2%)	10 (8.3%)	87 (5.5%)
(5) Unacceptable	4 (0.5%)	5 (1.1%)	1 (0.5%)	1 (0.8%)	11 (0.7%)
<b>Q4. Rate the overall handling and ease of implant using the Pre-formed Atrial J lead</b>					
(1) Exceeded Expectations	Not applicable	Not applicable	Not applicable	20 (16.8%)	20 (16.8%)
(2) Very Good	Not applicable	Not applicable	Not applicable	57 (47.9%)	57 (47.9%)
(3) Good	Not applicable	Not applicable	Not applicable	29 (24.4%)	29 (24.4%)
(4) Met Expectations	Not applicable	Not applicable	Not applicable	13 (10.9%)	13 (10.9%)

Boston Scientific Confidential. Unauthorized use is prohibited.

**LIT APPROVAL-INGEVITY Clinical Study Summary**

Item	Number of Responses (%)				
	RV Active Leads (N=844)	RA Active Leads (N=475)	RV Passive Leads (N=213)	RA Passive Leads (N=121)	All Leads (N=1653)
(5) Unacceptable	Not applicable	Not applicable	Not applicable	0 (0%)	0 (0%)
Q5. (Single Chamber) - The Lead is easy to pass through small vessels					
(1) Strongly Agree	51 (38.9%)	Not applicable	18 (40.9%)	Not applicable	69 (39.4%)
(2) Agree	75 (57.3%)	Not applicable	24 (54.5%)	Not applicable	99 (56.6%)
(3) Somewhat Agree	5 (3.8%)	Not applicable	2 (4.5%)	Not applicable	7 (4.0%)
(4) Disagree	0 (0%)	Not applicable	0 (0%)	Not applicable	0 (0%)
Q6. (Dual Chamber) - The Lead is easy to pass through small vessels and/or vessels with multiple leads					
(1) Strongly Agree	191 (30.3%)	117 (29.6%)	47 (29.7%)	33 (28.0%)	388 (29.8%)
(2) Agree	398 (63.2%)	246 (62.3%)	100 (63.3%)	76 (64.4%)	820 (63.0%)
(3) Somewhat Agree	35 (5.6%)	30 (7.6%)	10 (6.3%)	7 (5.9%)	82 (6.3%)
(4) Disagree	6 (1.0%)	2 (0.5%)	1 (0.6%)	2 (1.7%)	11 (0.8%)
Q7. Rate the visibility of the radiopaque suture sleeve on x-ray during and after the implant procedure					
(1) Exceeded Expectations	94 (14.1%)	40 (11.6%)	21 (11.7%)	8 (7.4%)	163 (12.5%)
(2) Very Good	284 (42.6%)	143 (41.3%)	77 (43.0%)	53 (49.1%)	557 (42.9%)
(3) Good	186 (27.9%)	94 (27.2%)	58 (32.4%)	38 (35.2%)	376 (28.9%)
(4) Met Expectations	87 (13.1%)	55 (15.9%)	20 (11.2%)	9 (8.3%)	171 (13.2%)
(5) Unacceptable	15 (2.3%)	14 (4.0%)	3 (1.7%)	0 (0.0%)	32 (2.5%)
Q8. The design of the low profile suture sleeve helps minimize bulk in the pocket					
(1) Strongly Agree	155 (19.3%)	69 (16.0%)	36 (17.1%)	23 (19.0%)	283 (18.0%)
(2) Agree	439 (54.5%)	240 (55.7%)	127 (60.2%)	73 (60.3%)	879 (56.1%)
(3) Somewhat Agree	146 (18.1%)	83 (19.3%)	32 (15.2%)	19 (15.7%)	280 (17.9%)
(4) Disagree	65 (8.1%)	39 (9.0%)	16 (7.6%)	6 (5.0%)	126 (8.0%)



Boston Scientific Confidential. Unauthorized use is prohibited.

**LIT APPROVAL-INGEVITY Clinical Study Summary**

# Boston Scientific

Boston Scientific Corporation  
4100 Hamline Avenue North  
St. Paul, MN 55112-5798 USA

[www.bostonscientific.com](http://www.bostonscientific.com)

1.800.CARDIAC (227.3422)  
+1.651.582.4000

© 2015 Boston Scientific Corporation or its affiliates.  
All Rights Reserved.

358487-023 EN US 2015-10



Boston Scientific Confidential. Unauthorized use is prohibited.

**LIT APPROVAL-INGEVITY Clinical Study Summary**

REFERENCE GUIDE

**ACCOLADE™**

**ACCOLADE™ MRI**

Model L300, L301, L321, L310, L311, L331

**PROPONENT™**

**PROPONENT™ MRI**

Model L200, L201, L221, L210, L211, L231

**ESSENTIO™**

**ESSENTIO™ MRI**

Model L100, L101, L121, L110, L111, L131

**ALTRUA™ 2**

Model S701, S702, S722

**FORMIO™**

**FORMIO™ MRI**

Model K278, K279

**VITALIO™**

**VITALIO™ MRI**

Model K272, K273, K274, K275, K276, K277

**INGENIO™**

**INGENIO™ MRI**

Model K172, K173, K174, K175, K176, K177

**ADVANTIO™**

Model K062, K063, K064

**PACEMAKER**

**CAUTION:** Federal law (USA) restricts this device to sale by or on the order of a physician trained or experienced in device implant and follow-up procedures.

Boston Scientific Confidential. Unauthorized use is prohibited.

**LIT APPROVAL - INGENIO 1-2 MRI REF GUIDE US**

# ABOUT THIS MANUAL

---

## INTENDED AUDIENCE

This literature is intended for use by professionals trained or experienced in device implant and/or follow-up procedures.

This family of implantable pacemakers contains both single- and dual-chamber pulse generators that provide atrial and/or ventricular pacing and sensing and a variety of diagnostic tools.

The Physician Technical Manual, used in conjunction with the ZOOMVIEW software, is intended to provide information most relevant for implanting the pulse generator. This Reference Guide provides further descriptions of programmable features and diagnostics.

Summaries of the relevant clinical studies supporting this product are available as separate documents. The following clinical summaries are approved as applicable to the devices described in this manual:

- GDT1000 Sensing Acute Study
- COGENT-4 Field Following Study
- INSIGNIA I Ultra
- PULSAR MAX
- COGNATE
- IVORY
- SAMURAI

For information about MRI scanning, refer to the ImageReady MR Conditional Pacing System MRI Technical Guide.

To view and download any of these documents, go to [www.bostonscientific.com/ifu](http://www.bostonscientific.com/ifu).

## NEW OR ENHANCED FEATURES

These pulse generator systems include additional or enhanced features as compared to previous Boston Scientific pacemakers.

The list below is intended to highlight some of these features; it is not a comprehensive list. Please refer to the feature-specific content elsewhere in this manual for detailed descriptions of these features.

**The following new or enhanced features apply to ACCOLADE, PROPONENT, ESSENTIO, and/or ALTRUA 2 devices.**

### User Experience

- EasyView header with port identifiers: increased header transparency is designed to provide enhanced visibility of the lead ports and ease of individual port identification.
- MICS Telemetry: RF telemetry band utilized is MICS (Medical Implant Communication Service).
  - FCC ID: ESCCRMU22814

The following are trademarks of Boston Scientific or its affiliates: ACCOLADE, ADVANTIO, ALTRUA, EASYVIEW, ESSENTIO, FORMIO, IMAGEREADY, INGENIO, INSIGNIA, LATITUDE, PaceSafe, PROPONENT, QUICK NOTES, RightRate, RYTHMIQ, Safety Core, Smart Blanking, VITALIO, ZIP, ZOOM, ZOOMVIEW.

Boston Scientific Confidential. Unauthorized use is prohibited.

**LIT APPROVAL - INGENIO 1-2 MRI REF GUIDE US**

## Patient Diagnostics

- Programmable Lead Impedance Limits for daily measurements: the High Impedance Limit is programmable between 2000 and 3000  $\Omega$  and the Low Impedance Limit is programmable between 200 and 500  $\Omega$ .
- Snapshot: up to 6 unique traces of the ECG/EGM display can be stored at any time by pressing the Snapshot button. The traces are 10 seconds pre-activation and 2 seconds post-activation. A 10 second trace will automatically be stored at the end of Pace Threshold tests, which counts as one of the 6 snapshots.
- Atrial Arrhythmia Report: AT/AF % and Total Time in AT/AF Counters are provided. AT/AF Burden, RV Rate during AT/AF, Pacing Percent, Heart Rate, Activity Level and Respiratory Rate Trends are provided. Histograms are provided for RV Rate during AT/AF. A timeline history of interrogations, programming, and counter resets for one year is collected. The Longest AT/AF, Fastest RVS rate in AT/AF, and most recent episode information is also collected.
- POST (Post-Operative System Test): provides an automatic device/lead check at a pre-determined time post-implant to help document proper system functionality without requiring manual system testing.

**The following new or enhanced features apply to FORMIO, VITALIO, INGENIO, and/or ADVANTIO devices.**

## User Experience

- Hardware: the number of setscrews has been reduced to one setscrew per port.
- ZIP Telemetry: provides wandless, two-way RF communication with the pulse generator.
  - FCC ID: ESCCRMV17311
- ZOOMVIEW Programmer Software: the new user interface is consistent across Boston Scientific brady, tachy, and heart failure devices.
- Indications-Based Programming (IBP): allows you to set up programming parameters based on the patient's clinical needs and indications.
- Single Chamber Devices: incorporates programmability to select atrial or ventricular specific modes.
- USB storage devices are supported: pulse generator data can be saved and transferred to a USB pen drive.
- PDF versions of reports are available.

## Tachy Detection

- Ventricular Tachy EGM Storage utilizes the strengths of an ICD-based tachycardia detection strategy including a V > A detection enhancement.

## Brady Therapy

- New brady modes available include VDDR and Off.
- AV Search+: designed to reduce unnecessary RV pacing for patients with intact or intermittent AV conduction by allowing intrinsic AV conduction beyond the programmed AV delay during episodes of normal AV nodal function.

Boston Scientific Confidential. Unauthorized use is prohibited.

**LIT APPROVAL - INGENIO 1-2 MRI REF GUIDE US**

- PaceSafe RA Automatic Threshold: automatically performs atrial threshold testing every 21 hours and sets a 2:1 output safety margin.
- RightRate Pacing: utilizes minute ventilation to provide rate adaptive pacing based on physiologic changes along with automatic calibration, a simplified user interface, and filtering designed to mitigate MV interactions.
- RYTHMIQ: designed to reduce unnecessary right ventricular (RV) pacing for patients with intact atrioventricular (AV) conduction by providing mode switching between AAI(R) pacing with ventricular backup pacing rate support and DDD(R).
- Safety Core: safety architecture is utilized to provide basic pacing if non-recoverable or repeated fault conditions occur.
- Electrocautery Protection: provides asynchronous pacing operation at the LRL.
- MRI Protection Mode: a device mode that modifies certain pulse generator functions in order to mitigate risks associated with exposing the pacing system to the MRI environment.

### **Sensing**

- Automatic gain control (AGC): dynamically adjusts sensitivity in both the atrium and ventricle.
- Smart Blanking: used in conjunction with AGC sensing to promote appropriate cross-chamber sensing capabilities.

### **Patient Diagnostics**

- Programmable Lead Impedance Limits for daily measurements: the Low Impedance Limit is programmable between 200 and 500  $\Omega$ .
- Snapshot: up to 6 unique traces of the ECG/EGM display can be stored at any time by pressing the Snapshot button. The traces are 10 seconds pre-activation and 2 seconds post-activation. A 10 second trace will automatically be stored at the end of Pace Threshold tests, which counts as one of the 6 snapshots.
- A counter for Total Time in AT/AF is provided.
- Trends: expanded set of trends is provided including:
  - Heart Rate
  - Respiratory Rate
  - AT/AF Burden (including total number of episodes)
  - Events
- Heart Rate Variability: includes HRV Footprint, SDANN, and ABM trends.
- Average V Rate in ATR: provides the average ventricular rate during ATR episodes.
- Arrhythmia Logbook: memory is allocated between numerous episode types with increased data storage available.
- Lead Safety Switch: diagnostic information is provided to show the date and impedance value which caused the LSS.

Boston Scientific Confidential. Unauthorized use is prohibited.

**LIT APPROVAL - INGENIO 1-2 MRI REF GUIDE US**

This product family includes single- and dual-chamber models, with feature variations. This manual describes the full-featured model (e.g., a dual-chamber model with ZIP telemetry).

This guide may contain reference information for model numbers that are not currently approved for sale in all geographies. For a complete list of model numbers approved in your geography, consult with your local sales representative. Some model numbers may contain fewer features; for those devices, disregard descriptions of the unavailable features. Descriptions found within this manual apply to all device tiers unless otherwise noted. References to names of non-MRI devices also apply to the corresponding MRI devices. References to "ICD" include all types of ICDs (e.g., ICD, CRT-D, S-ICD).

The screen illustrations used in this manual are intended to familiarize you with the general screen layout. The actual screens you see when interrogating or programming the pulse generator will vary based on the model and programmed parameters.

LATITUDE NXT is a remote monitoring system that provides pulse generator data for clinicians. These pulse generators are designed to be LATITUDE NXT enabled; availability varies by region.

LATITUDE NXT is available for the following devices: ACCOLADE, PROPONENT, ESSENTIO, FORMIO, VITALIO, INGENIO, and ADVANTIO.

A complete list of programmable options is provided in the appendix ("Programmable Options" on page A-1). The actual values you see when interrogating or programming the pulse generator will vary based on the model and programmed parameters.

The text conventions discussed below are used throughout this manual.

- |            |   |
|------------|---|
| PRM KEYS   | The names of Programmer/Recorder/Monitor (PRM) keys appear in capital letters (e.g., PROGRAM, INTERROGATE). |
| 1., 2., 3. | Numbered lists are used for instructions that should be followed in the order given.                        |
| •          | Bulleted lists are used when the information is not sequential.   |

The following acronyms may be used in this Reference Guide:

<b>A</b>	Atrial
<b>ABM</b>	Autonomic Balance Monitor
<b>AF</b>	Atrial Fibrillation
<b>AFR</b>	Atrial Flutter Response
<b>AGC</b>	Automatic Gain Control
<b>AT</b>	Atrial Tachycardia
<b>ATP</b>	Antitachycardia Pacing
<b>ATR</b>	Atrial Tachy Response
<b>AV</b>	Atrioventricular
<b>BPEG</b>	British Pacing and Electrophysiology Group
<b>BTR</b>	Brady Tachy Response
<b>CPR</b>	Cardiopulmonary Resuscitation
<b>CRT-D</b>	Cardiac Resynchronization Therapy Defibrillator
<b>EAS</b>	Electronic Article Surveillance
<b>ECG</b>	Electrocardiogram
<b>EF</b>	Ejection Fraction
<b>EGM</b>	Electrogram
<b>EL</b>	Extended Longevity
<b>EMI</b>	Electromagnetic Interference
<b>EP</b>	Electrophysiology; Electrophysiologic
<b>FCC</b>	Federal Communications Commission
<b>HRV</b>	Heart Rate Variability
<b>IBP</b>	Indications-Based Programming

Boston Scientific Confidential. Unauthorized use is prohibited.

LIT APPROVAL - INGENIO 1-2 MRI REF GUIDE US



<b>ICD</b>	Implantable Cardioverter Defibrillator
<b>LRL</b>	Lower Rate Limit
<b>MI</b>	Myocardial Infarction
<b>MICS</b>	Medical Implant Communication Service
<b>MPR</b>	Maximum Pacing Rate
<b>MRI</b>	Magnetic Resonance Imaging
<b>MSR</b>	Maximum Sensor Rate
<b>MTR</b>	Maximum Tracking Rate
<b>MV</b>	Minute Ventilation
<b>NASPE</b>	North American Society of Pacing and Electrophysiology
<b>NSR</b>	Normal Sinus Rhythm
<b>NSVT</b>	Nonsustained Ventricular Tachycardia
<b>PAC</b>	Premature Atrial Contraction
<b>PAT</b>	Paroxysmal Atrial Tachycardia
<b>PES</b>	Programmed Electrical Stimulation
<b>PMT</b>	Pacemaker-Mediated Tachycardia
<b>POST</b>	Post-Operative System Test
<b>PRM</b>	Programmer/Recorder/Monitor
<b>PSA</b>	Pacing System Analyzer
<b>PTM</b>	Patient Triggered Monitor
<b>PVARP</b>	Post-Ventricular Atrial Refractory Period
<b>PVC</b>	Premature Ventricular Contraction
<b>RAAT</b>	Right Atrial Automatic Threshold
<b>RADAR</b>	Radio Detection and Ranging
<b>RF</b>	Radio Frequency
<b>RRT</b>	Respiratory Rate Trend
<b>RV</b>	Right Ventricular
<b>RVAC</b>	Right Ventricular Automatic Capture
<b>RVRP</b>	Right Ventricular Refractory Period
<b>SBR</b>	Sudden Bradycardia Response
<b>SCD</b>	Sudden Cardiac Death
<b>SDANN</b>	Standard Deviation of Averaged Normal-to-Normal R-R intervals
<b>S-ICD</b>	Subcutaneous Implantable Cardioverter Defibrillator
<b>SVT</b>	Supraventricular Tachycardia
<b>TARP</b>	Total Atrial Refractory Period
<b>TENS</b>	Transcutaneous Electrical Nerve Stimulation
<b>V</b>	Ventricular
<b>VF</b>	Ventricular Fibrillation
<b>VRP</b>	Ventricular Refractory Period
<b>VRR</b>	Ventricular Rate Regulation
<b>VT</b>	Ventricular Tachycardia

Boston Scientific Confidential. Unauthorized use is prohibited.

**LIT APPROVAL - INGENIO 1-2 MRI REF GUIDE US**

# TABLE OF CONTENTS

<b>USING THE PROGRAMMER/RECORDER/MONITOR.....</b>	<b>1-1</b>
<b>CHAPTER 1</b>	
ZOOM LATITUDE Programming System .....	1-2
Software Terminology and Navigation .....	1-2
Main Screen .....	1-2
PRM Mode Indicator .....	1-3
ECG/EGM Display .....	1-3
Toolbar .....	1-4
Tabs .....	1-5
Buttons .....	1-5
Icons .....	1-5
Common Objects .....	1-7
Use of Color .....	1-7
Demonstration Mode .....	1-8
Communicating with the Pulse Generator .....	1-8
ZIP Telemetry .....	1-8
Starting a Wanded Telemetry Session .....	1-9
Starting a ZIP Telemetry Session .....	1-9
Ending a Telemetry Session .....	1-10
ZIP Telemetry Security .....	1-10
ZIP Telemetry Security .....	1-12
Indications-Based Programming (IBP) .....	1-14
Manual Programming .....	1-16
DIVERT THERAPY .....	1-16
STAT PACE .....	1-17
Data Management .....	1-17
Patient Information .....	1-18
Data Storage .....	1-18
Device Memory .....	1-19
Print .....	1-19
Safety Mode .....	1-19
Backup Pacemaker .....	1-20
<b>PACING THERAPIES .....</b>	<b>2-1</b>
<b>CHAPTER 2</b>	
Pacing Therapies .....	2-2
Device Modes .....	2-2
Electrocautery Protection Mode .....	2-3
MRI Protection Mode .....	2-3
Basic Parameters .....	2-5
Brady Mode .....	2-5
Lower Rate Limit (LRL) .....	2-9
Maximum Tracking Rate (MTR) .....	2-9

Boston Scientific Confidential. Unauthorized use is prohibited.

**LIT APPROVAL - INGENIO 1-2 MRI REF GUIDE US**

Maximum Sensor Rate (MSR) .....	2-11
Runaway Protection .....	2-12
Pulse Width .....	2-12
Amplitude .....	2-13
PaceSafe .....	2-13
Sensitivity .....	2-21
Temporary Brady Pacing .....	2-26
Rate Adaptive Pacing and Sensor Trending .....	2-26
Rate Adaptive Pacing .....	2-26
Accelerometer .....	2-27
Minute Ventilation (MV) .....	2-31
Sensor Trending .....	2-40
Atrial Tachy Response .....	2-43
ATR Mode Switch .....	2-43
Ventricular Rate Regulation (VRR) .....	2-45
Atrial Flutter Response (AFR) .....	2-46
PMT Termination .....	2-47
Rate Enhancements .....	2-48
Rate Hysteresis .....	2-48
Rate Smoothing .....	2-49
Rate Smoothing Example Based on a Dual-Chamber Tracking Mode .....	2-51
Sudden Brady Response .....	2-52
Lead Configuration .....	2-54
Use of Atrial Information .....	2-55
Lead Safety Switch .....	2-56
AV Delay .....	2-57
Paced AV Delay .....	2-57
Sensed AV Delay .....	2-58
AV Search + .....	2-60
RYTHMIQ .....	2-61
Refractory .....	2-62
A-Refractory - PVARP .....	2-63
A Refractory - same chamber .....	2-65
RV-Refractory (RVRP) .....	2-65
Cross-Chamber Blanking .....	2-66
Noise Response .....	2-69
<b>SYSTEM DIAGNOSTICS .....</b>	<b>3-1</b>
<b>CHAPTER 3</b>	
Summary Dialog .....	3-2
Battery Status .....	3-2
Leads Status .....	3-6
Post-Operative System Test (POST) .....	3-11
Lead Tests .....	3-11
Intrinsic Amplitude Test .....	3-12

Boston Scientific Confidential. Unauthorized use is prohibited.

LIT APPROVAL - INGENIO 1-2 MRI REF GUIDE US

Lead Impedance Test.....	3-12
Pace Threshold Test .....	3-13
<b>PATIENT DIAGNOSTICS AND FOLLOW UP .....</b>	<b>4-1</b>
<b>CHAPTER 4</b>	
Therapy History .....	4-2
Arrhythmia Logbook .....	4-2
Snapshot .....	4-8
Histograms .....	4-9
Counters.....	4-10
Ventricular Tachy Counters .....	4-10
Brady Counters .....	4-10
Heart Rate Variability (HRV).....	4-11
Trends .....	4-14
Post Implant features.....	4-18
Patient Triggered Monitor (PTM).....	4-18
Magnet Feature.....	4-19
<b>ELECTROPHYSIOLOGIC TESTING.....</b>	<b>5-1</b>
<b>CHAPTER 5</b>	
EP Test Features .....	5-2
EP Test Screen .....	5-2
Induction Methods .....	5-3
Backup Ventricular Pacing During Atrial EP Testing .....	5-3
Programmed Electrical Stimulation (PES) .....	5-3
Manual Burst Pacing.....	5-5
<b>PROGRAMMABLE OPTIONS.....</b>	<b>A-1</b>
<b>APPENDIX A</b>	
<b>SYMBOLS ON PACKAGING.....</b>	<b>B-1</b>
<b>APPENDIX B</b>	
Symbols on Packaging.....	B-1

Boston Scientific Confidential. Unauthorized use is prohibited.

**LIT APPROVAL - INGENIO 1-2 MRI REF GUIDE US**

# USING THE PROGRAMMER/RECORDER/MONITOR

---

## CHAPTER 1

This chapter contains the following topics:

- "ZOOM LATITUDE Programming System" on page 1-2
- "Software Terminology and Navigation" on page 1-2
- "Demonstration Mode" on page 1-8
- "Communicating with the Pulse Generator" on page 1-8
- "Indications-Based Programming (IBP)" on page 1-14
- "Manual Programming" on page 1-16
- "DIVERT THERAPY" on page 1-16
- "STAT PACE" on page 1-17
- "Data Management" on page 1-17
- "Safety Mode" on page 1-19

## ZOOM LATITUDE PROGRAMMING SYSTEM

The ZOOM LATITUDE Programming System is the external portion of the pulse generator system and includes:

- Model 3120 Programmer/Recorder/Monitor (PRM)
- Model 3140 ZOOM Wireless Transmitter
- Model 2869 ZOOMVIEW Software Application
- Model 6577 Accessory Telemetry Wand

The ZOOMVIEW software provides advanced device programming and patient monitoring technology. It was designed with the intent to:

- Enhance device programming capability
- Improve patient and device monitoring performance
- Simplify and expedite programming and monitoring tasks

You can use the PRM system to do the following:

- Interrogate the pulse generator
- Program the pulse generator to provide a variety of therapy options
- Access the pulse generator's diagnostic features
- Perform noninvasive diagnostic testing
- Access therapy history data
- Store a 12 second trace of the ECG/EGM display from any screen
- Access an interactive Demonstration Mode or Patient Data Mode without the presence of a pulse generator
- Print patient data including pulse generator therapy options and therapy history data
- Save patient data

You can program the pulse generator using two methods: automatically using IBP or manually.

For more detailed information about using the PRM or ZOOM Wireless Transmitter, refer to the PRM Operator's Manual or ZOOM Wireless Transmitter Reference Guide.

## SOFTWARE TERMINOLOGY AND NAVIGATION

This section provides an overview of the PRM system.

### Main Screen

The main PRM screen is shown below, followed by a description of the components (Figure 1-1 on page 1-3).



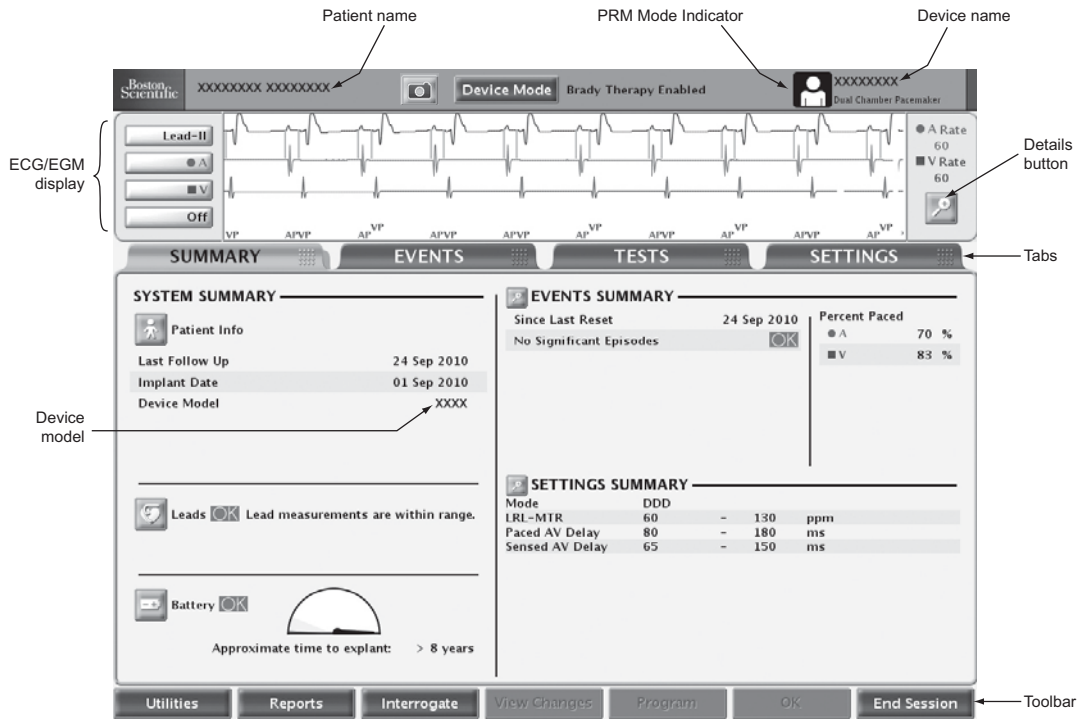

Figure 1-1. Main Screen

## PRM Mode Indicator

The PRM Mode Indicator displays at the top of the screen to identify the current PRM operational mode.



**Patient**—indicates that the PRM is displaying data obtained by communicating with a device.



**Patient Data**—indicates that the PRM is displaying stored patient data.



**Demo Mode**—indicates that the PRM is displaying sample data and operating in demonstration mode.

## ECG/EGM Display

The ECG area of the screen shows real-time status information about the patient and the pulse generator that can be useful in evaluating system performance. The following types of traces can be selected:

- Surface ECGs are transmitted from body surface lead electrodes that are connected to the PRM, and can be displayed without interrogating the pulse generator.

- Real-time EGMs are transmitted from the pace/sense electrodes, and are often used to evaluate lead system integrity and help identify faults such as lead fractures, insulation breaks, or dislodgments.

Real-time EGMs can only be displayed upon interrogation of the pulse generator. Because they rely on ZIP or wanded telemetry, they are susceptible to radio frequency interference. Significant interference may cause a break or drop-out of real-time EGMs ("ZIP Telemetry Security" on page 1-10).

- At any time, a 12 second trace of the ECG/EGM display can be stored by pressing the Snapshot button from any screen.

**NOTE:** If the PRM is left idle for 15 minutes (or 28 minutes if the pulse generator was in Storage Mode at interrogation) real-time EGMs are shut off. The PRM provides a dialog box allowing real-time EGMs to be restored.

**NOTE:** In the presence of telemetry interference, the real-time intracardiac EGM traces and markers may become misaligned from the real-time surface ECG traces. When the telemetry link has improved, re-select any of the intracardiac EGM traces to cause re-initialization.

You can select the Details button to enlarge the ECG/EGM screen. The following options are available:

- Show Device Markers—displays annotated event markers, which identify certain intrinsic cardiac and device-related events, and provide information such as sensed/paced events
- Enable Surface Filter—minimizes noise on the surface ECG
- Display Pacing Spikes—shows detected pacing spikes, annotated by a marker on the surface ECG waveform
- Trace Speed—adjusts the speed of the trace (0, 25, or 50 mm/s). As the speed is increased, the time/horizontal scale is expanded
- Gain—adjusts the amplitude/vertical scale (AUTO, 1, 2, 5, 10, or 20 mm/mV) for each channel. As the gain is increased, the amplitude of the signal is enlarged

You can print real-time EGMs, which include annotated event markers, by performing the following steps:

1. Press one of the print speed keys on the PRM (e.g., speed key 25) to begin printing.
2. Press the 0 (zero) speed key to stop printing.
3. Press the paper-feed key to fully eject the last printed sheet.

You can print definitions of the annotated markers by pressing the calibration key while the EGM is printing. Alternatively you can print a full report containing the definitions of all of the annotated markers by performing the following steps:

1. From the toolbar, click the Reports button. The Reports window displays.
2. Select the Marker Legend checkbox.
3. Click the Print button. The Marker Legend Report is sent to the printer.

## Toolbar

The toolbar allows you to perform the following tasks:

- Select system utilities

Boston Scientific Confidential. Unauthorized use is prohibited.

**LIT APPROVAL - INGENIO 1-2 MRI REF GUIDE US**

- Generate reports
- Interrogate and program the pulse generator
- View pending or programmed changes
- View attentions and warnings
- End your PRM session

## Tabs

Tabs allow you to select PRM tasks, such as viewing summary data or programming device settings. Selecting a tab displays the associated screen. Many screens contain additional tabs, which allow you to access more detailed settings and information.

## Buttons

Buttons are located on screens and dialogs throughout the application. Buttons allow you to perform various tasks, including:

- Obtain detailed information
- View setting details
- Set programmable values
- Load initial values

When a button selection opens a window in front of the Main Screen, a Close button displays in the upper-right corner of the window to allow you to close the window and return to the Main Screen.

## Icons

Icons are graphic elements that, when selected, may initiate an activity, display lists or options, or change the information displayed.



Details—opens a window containing detailed information.



Patient—opens a window with patient information details.



Leads—opens a window with details on leads.



Battery—opens a window with details on the pulse generator battery.



Check—indicates that an option is selected.



Event—indicates that an event has occurred. When you view the Trends timeline on the Events tab, event icons display wherever events have occurred. Selecting an events icon displays details about the event.



Information—indicates information that is provided for reference.

### Action Icons



Run—causes the programmer to perform an action.



Hold—causes the programmer to pause an action.



Continue—causes the programmer to continue an action.



Snapshot—causes the programmer to store a 12 second trace of the ECG/EGM display from any screen.



POST Complete—opens the Reports window to print POST information on the Quick Notes or Follow-Up Reports.

### Slider Icons



Horizontal Slider—indicates that a slider object can be clicked and dragged left or right.



Vertical Slider—indicates that a slider object can be clicked and dragged up or down.

### Sort Icons



Sort Ascending—indicates that Ascending sort is currently selected on a table column sort button. (e.g., 1, 2, 3, 4, 5)



Sort Descending—indicates that Descending sort is currently selected on a table column sort button. (e.g., 5, 4, 3, 2, 1)

### Increment and Decrement Icons



Increment—indicates that an associated value can be incremented.



Decrement—indicates that an associated value can be decremented.

**Scroll Icons**



Scroll Left—indicates that an associated item can be scrolled left.



Scroll Right—indicates that an associated item can be scrolled right.



Scroll Up—indicates that an associated item can be scrolled up.



Scroll Down—indicates that an associated item can be scrolled down.

**Common Objects**

Common objects such as status bars, scroll bars, menus, and dialogs are used throughout the application. These operate similarly to the objects found in web browsers and other computer applications.

**Use of Color**

Colors and symbols are used to highlight buttons, icons, and other objects, as well as certain types of information. The use of specific color conventions and symbols is intended to provide a more consistent user experience and simplify programming. Refer to the table below to understand how colors and symbols are used on the PRM screens (Table 1-1 on page 1-7).

**Table 1-1. PRM color conventions**

Color	Meaning	Examples	Symbol
Red	Indicates warning conditions	The selected parameter value is not allowed; click the red warning button to open the Parameter Interactions screen, which provides information about corrective action.	
		Device and patient diagnostic information that requires serious consideration.	
Yellow	Indicates conditions requiring your attention	The selected parameter value is allowed, but not recommended; click the yellow attention button to open the Parameter Interactions screen, which provides information about corrective action.	
		Device and patient diagnostic information that should be addressed.	
Green	Indicates acceptable changes or conditions	The selected parameter value is allowed, but is still pending.	
		There is no device or patient diagnostic information requiring your specific attention.	
White	Indicates the value that is currently programmed		

## DEMONSTRATION MODE

The PRM includes a Demonstration Mode feature, which enables the PRM to be used as a self-teaching tool. When selected, this mode allows you to practice PRM screen navigation without interrogating a pulse generator. You can use Demonstration Mode to familiarize yourself with many of the specific screen sequences that will display when interrogating or programming a specific pulse generator. You can also use Demonstration Mode to examine available features, parameters, and information.

To access Demonstration Mode, select the appropriate PG from the Select PG screen, and then select Demo from the Select PG Mode dialog. When the PRM is operating in Demonstration Mode, the PRM Mode Indicator displays the Demo Mode icon. The pulse generator cannot be programmed when the PRM is operating in Demonstration Mode. Exit the Demonstration Mode before attempting to interrogate or program the pulse generator.

## COMMUNICATING WITH THE PULSE GENERATOR

The PRM communicates with the pulse generator using a telemetry wand.

After initiating communication with the wand, the PRM can use wandless ZIP telemetry (two-way RF communication) to interface with some pulse generator models.

Telemetry is required to:

- Direct commands from the PRM system, such as:
  - INTERROGATE
  - PROGRAM
  - STAT PACE
  - DIVERT THERAPY
- Modify device parameter settings
- Conduct EP testing
- Conduct diagnostic tests including the following:
  - Pacing impedance tests
  - Pacing threshold tests
  - Intrinsic amplitude tests

## ZIP Telemetry

ZIP telemetry is available in ACCOLADE, PROPONENT, and ESSENTIO devices and operates with a transmit frequency of 402 to 405 MHz. ZIP telemetry is available in FORMIO, VITALIO, INGENIO, and ADVANTIO devices and operates with a transmit frequency of 916.5 MHz.

ZIP telemetry is a wandless, two-way RF communication option that allows the PRM system to communicate with these RF capable pulse generators.

- For ACCOLADE, PROPONENT, and ESSENTIO devices, RF communication is enabled by the ZOOM Wireless Transmitter unit connected to the PRM. When initiating communication, wanded telemetry is needed. When ZIP telemetry is ready for use, a message will display on the PRM screen indicating that the wand can be removed. Otherwise, the session will continue with wanded telemetry.
- For FORMIO, VITALIO, INGENIO, and ADVANTIO devices, when a wanded telemetry session is initiated, the PRM checks the pulse generator’s telemetry capability. If the PRM detects a pulse generator with ZIP telemetry capability, a message will display indicating that ZIP telemetry is available and the wand can be removed. Otherwise, the session will continue with wanded telemetry.

ZIP telemetry offers the following advantages over traditional wanded telemetry:

- The faster data transmission speed means less time is required for device interrogation
- Data transmission over a longer distance (within 3 m [10 ft]) minimizes the need to keep the wand in the sterile field during implant, which may reduce the risk of infection
- Continuous telemetry is possible during the entire implant procedure, allowing monitoring of pulse generator performance and lead integrity during implant
- Allows the physician to continue with the operating procedure while the device is being programmed for the patient

Regardless of whether ZIP telemetry is being used, wanded communication is still available.

## Starting a Wanded Telemetry Session

Follow this procedure to begin a wanded telemetry communication session:

1. Make sure the telemetry wand is connected to the PRM system and is available throughout the session.
2. Position the wand over the pulse generator at a distance not greater than 6 cm (2.4 inches).
3. Use the PRM to Interrogate the pulse generator.
4. Retain the wand position whenever communication is required.

## Starting a ZIP Telemetry Session

Follow this procedure to begin a ZIP telemetry communication session:

1. For ACCOLADE, PROPONENT, and ESSENTIO devices, verify that the ZOOM Wireless Transmitter is connected to the PRM via the USB cable and that the green light on top of the transmitter is illuminated (indicating the transmitter is ready for use).
2. Start a wanded telemetry session. Verify that the wand cord is within reach of the pulse generator to enable the use of wanded telemetry should it become necessary.

3. Keep the telemetry wand in position until either a message appears, indicating that the telemetry wand may be removed from proximity of the pulse generator, or the ZIP telemetry light illuminates on the PRM system.

## Ending a Telemetry Session

Select the End Session button to quit a telemetry session and return to the startup screen. You can choose to end the session or return to the current session. Upon ending a session, the PRM system terminates all communication with the pulse generator.

## ZIP Telemetry Security

**The following ZIP Telemetry Security information applies to devices operating with a transmit frequency of 402 to 405 MHz.**

The pulse generator contains a compliant low-power transceiver. The pulse generator can only be interrogated or programmed by RF signals that employ the proprietary ZIP telemetry protocol. The pulse generator verifies that it is communicating with a ZOOMVIEW system before responding to any RF signals. The pulse generator stores, transmits, and receives individually identifiable health information in an encrypted format.

ZIP telemetry is possible when all of the following conditions are met:

- ZIP telemetry for the PRM is enabled
- The ZOOM Wireless Transmitter is connected to the PRM via the USB cable
- The indicator light on top of the ZOOM Wireless Transmitter is green; indicating the transmitter is ready for use
- The pulse generator is within range of the PRM system
- The pulse generator has not reached Explant; note that a total of 1.5 hours of ZIP telemetry will be available after the pulse generator reaches Explant
- The pulse generator battery capacity is not depleted
- Pulse generator is not in MRI Protection Mode

In order to meet local communications rules and regulations, ZIP telemetry should not be used when the pulse generator is outside its normal operating temperature of 20°C–45°C (68°F–113°F).

Communication can be supported between multiple PRMs and pulse generators at a time, as independent sessions. Signals from other sessions using RF communication or interference from other RF sources may interfere with or prevent ZIP telemetry communication.

**CAUTION:** RF signals from devices that operate at frequencies near that of the pulse generator may interrupt ZIP telemetry while interrogating or programming the pulse generator. This RF interference can be reduced by increasing the distance between the interfering device and the PRM and pulse generator. Examples of devices that may cause interference in the 916.5 MHz frequency band include:

- Cordless phone handsets or base stations
- Certain patient monitoring systems

Radio frequency interference may temporarily disrupt ZIP telemetry communication. The PRM will normally reestablish ZIP communication when the RF interference ends or subsides. Because continued RF interference may prevent ZIP telemetry communication, the system is designed to use wanded telemetry when ZIP telemetry is not available.

Boston Scientific Confidential. Unauthorized use is prohibited.

**LIT APPROVAL - INGENIO 1-2 MRI REF GUIDE US**



If ZIP telemetry is not available due to interference or if the ZOOM Wireless Transmitter is unplugged or not functioning properly, wanded telemetry communication with the PRM can be established. The system provides the following feedback to indicate that ZIP telemetry is not available:

- The ZIP telemetry indicator light on the PRM turns off
- The green indicator light on the ZOOM Wireless Transmitter is off
- If event markers and/or EGMs are activated, transmission of the event markers and/or EGMs will be interrupted
- If a command or other action has been requested, the PRM displays a notification indicating the wand should be placed in range of the pulse generator

ZIP telemetry operates consistently with wanded telemetry—no programming step can be completed unless the entire programming command has been received and confirmed by the pulse generator.

The pulse generator cannot be misprogrammed as a result of interrupted ZIP telemetry. Interruptions of ZIP telemetry may be caused by RF signals that operate at frequencies near that of the pulse generator and are strong enough to compete with the ZIP telemetry link between the pulse generator and the PRM. Significant interference may result in a break or drop-outs of real-time EGMs. If commands are interrupted, the PRM displays a message to place the wand on the pulse generator. Repeated displays of this message may indicate the presence of intermittent interference. These situations can be resolved by repositioning the ZOOM Wireless Transmitter attached to the PRM or by using standard wanded telemetry. There will be no interruption of device functionality or therapy during this period.

**NOTE:** *When both ZIP and wanded telemetry are being used (for example, switching from ZIP to wanded because of the presence of interference), the pulse generator will communicate with the programmer by ZIP telemetry when possible. If wanded telemetry only is desired, set the Communication Mode (accessed via the Utilities button) to use the wand for all telemetry.*

**NOTE:** *To conserve battery longevity, a ZIP telemetry session will be terminated if the pulse generator completely loses communication with the PRM for a continuous period of one hour (or 73 minutes if the device was in Storage Mode at interrogation). Wanded telemetry must be used to re-establish communication with the pulse generator after this period has elapsed.*

### **Considerations for Reducing Interference**

Increasing the distance from the source of interfering signals may enable the use of the ZIP telemetry channel.

Repositioning the ZOOM Wireless Transmitter may improve ZIP telemetry performance. If ZIP telemetry performance is not satisfactory, the option of using wanded telemetry is available.

Depending on the environment and PRM orientation relative to the pulse generator, the system is capable of maintaining ZIP telemetry communication at distances up to 3 m (10 ft). For optimum ZIP telemetry communication, position the ZOOM Wireless Transmitter within 3 m (10 ft) of the pulse generator and remove any obstruction between the ZOOM Wireless Transmitter and the pulse generator.

Positioning the ZOOM Wireless Transmitter at least 1 m (3 ft) away from walls or metal objects and ensuring the pulse generator (prior to implant) is not in direct contact with any metal objects may reduce signal reflection and/or signal blocking.

Avoid placing the ZOOM Wireless Transmitter in close proximity to monitors, high-frequency electrosurgical equipment, or strong magnetic fields since the telemetry link may be impaired.

Ensuring there are no obstructions (e.g., equipment, metal furniture, people, or walls) between the ZOOM Wireless Transmitter and pulse generator may improve signal quality. Personnel or objects that momentarily move between the ZOOM Wireless Transmitter and pulse generator during ZIP telemetry may temporarily interrupt communication, but will not affect device functionality or therapy.

Checking the time required to complete an interrogation after ZIP telemetry is established can provide an indication of whether interference is present. If an interrogation using ZIP telemetry takes less than 20 seconds, the current environment is likely free of interference. Interrogation times longer than 20 seconds (or short intervals of EGM drop-outs) indicate that interference may be present.

## ZIP Telemetry Security

**The following ZIP Telemetry Security information applies to devices operating with a transmit frequency of 916.5 MHz.**

The pulse generator contains a compliant low-power transceiver. The pulse generator can only be interrogated or programmed by RF signals that employ the proprietary ZIP telemetry protocol. The pulse generator verifies that it is communicating with a ZOOMVIEW system before responding to any RF signals. The pulse generator stores, transmits, and receives individually identifiable health information in an encrypted format.

ZIP telemetry is possible when all of the following conditions are met:

- ZIP telemetry for the PRM is enabled
- The pulse generator has RF communication capabilities
- The ZIP telemetry channel is available for use
- The pulse generator is within range of the PRM system
- The pulse generator has not reached Explant; note that a total of 1.5 hours of ZIP telemetry will be available after the pulse generator reaches Explant
- The pulse generator battery capacity is not depleted
- Pulse generator is not in MRI Protection Mode

In order to meet local communications rules and regulations, ZIP telemetry should not be used when the pulse generator is outside its normal operating temperature of 20°C–43°C (68°F–109°F).

Communication is supported between two PRMs and two pulse generators at a time, as two independent sessions. If there are two PRM–pulse generator communication sessions already occurring in the vicinity, a third session will not be allowed to start; wanded communication will be necessary in this case.

The PRM notifies you if ZIP telemetry is unavailable because of other sessions already in progress.

RF signals in the same frequency band used by the system may interfere with ZIP telemetry communication. These interfering signals include:

- Signals from other pulse generator/PRM system RF communication sessions after the maximum number of independent sessions has been reached. Other nearby pulse generators and PRMs using ZIP telemetry may prevent ZIP telemetry communication.

- Interference from other RF sources.

**CAUTION:** RF signals from devices that operate at frequencies near that of the pulse generator may interrupt ZIP telemetry while interrogating or programming the pulse generator. This RF interference can be reduced by increasing the distance between the interfering device and the PRM and pulse generator. Examples of devices that may cause interference in the 916.5 MHz frequency band include:

- Cordless phone handsets or base stations
- Certain patient monitoring systems

Radio frequency interference may temporarily disrupt ZIP telemetry communication. The PRM will normally reestablish ZIP communication when the RF interference ends or subsides. Because continued RF interference may prevent ZIP telemetry communication, the system is designed to use wanded telemetry when ZIP telemetry is not available.

If ZIP telemetry is not available, wanded telemetry communication with the PRM can be established. The system provides the following feedback to indicate that ZIP telemetry is not available:

- The ZIP telemetry indicator light on the PRM turns off
- If event markers and/or EGMs are activated, transmission of the event markers and/or EGMs is interrupted
- If a command or other action has been requested, the PRM displays a notification indicating the wand should be placed in range of the pulse generator

ZIP telemetry operates consistently with wanded telemetry—no programming step can be completed unless the entire programming command has been received and confirmed by the pulse generator.

The pulse generator cannot be misprogrammed as a result of interrupted ZIP telemetry. Interruptions of ZIP telemetry may be caused by RF signals that operate at frequencies near that of the pulse generator and are strong enough to compete with the ZIP telemetry link between the pulse generator and the PRM. Significant interference may result in a break or drop-outs of real-time EGMs. If commands are interrupted, the PRM displays a message to place the wand on the pulse generator. Repeated displays of this message may indicate the presence of intermittent interference. These situations can be resolved by repositioning the PRM or using standard wanded telemetry. There will be no interruption of device functionality or therapy during this period.

**NOTE:** *When both ZIP and wanded telemetry are being used (for example, switching from ZIP to wanded because of the presence of interference), the pulse generator will communicate with the programmer by ZIP telemetry when possible. If wanded telemetry only is desired, set the Communication Mode (accessed via the Utilities button) to use the wand for all telemetry.*

**NOTE:** *To conserve battery longevity, a ZIP telemetry session will be terminated if the pulse generator completely loses communication with the PRM for a continuous period of one hour (or 73 minutes if the device was in Storage Mode at interrogation). Wanded telemetry must be used to re-establish communication with the pulse generator after this period has elapsed.*

**NOTE:** *The PRM operates on a country-specific frequency range. The PRM determines the ZIP frequency range that the pulse generator uses based on the specific device model. If the PRM and pulse generator ZIP frequency ranges do not match, it indicates that the patient has traveled outside the country in which the pulse generator was implanted. The PRM will display a message indicating that ZIP telemetry cannot be used; however, the patient's pulse generator can be interrogated by using the wand. If out-of-country interrogation is needed, contact Boston Scientific using the information on the back cover of this manual.*

### **Considerations for Reducing Interference**

Increasing the distance from the source of interfering signals may enable the use of the ZIP telemetry channel. A minimum distance of 14 m (45 ft) is recommended between the source of interference (having an average output of 50 mW or less) and both the pulse generator and PRM.

Repositioning the PRM antenna or repositioning the PRM may improve ZIP telemetry performance. If ZIP telemetry performance is not satisfactory, the option of using wanded telemetry is available.

Positioning the PRM at least 1 m (3 ft) away from walls or metal objects and ensuring the pulse generator (prior to implant) is not in direct contact with any metal objects may reduce signal reflection and/or signal blocking.

Ensuring there are no obstructions (e.g., equipment, metal furniture, people, or walls) between the PRM and pulse generator may improve signal quality. Personnel or objects that momentarily move between the PRM and pulse generator during ZIP telemetry may temporarily interrupt communication, but will not affect device functionality or therapy.

Checking the time required to complete an interrogation after ZIP telemetry is established can provide an indication of whether interference is present. If an interrogation using ZIP telemetry takes less than 20 seconds, the current environment is likely free of interference. Interrogation times longer than 20 seconds (or short intervals of EGM drop-outs) indicate that interference may be present.

## **INDICATIONS-BASED PROGRAMMING (IBP)**

This feature is available in ACCOLADE, PROPONENT, FORMIO, VITALIO, and INGENIO devices.

IBP is a tool that provides specific programming recommendations based on the patient's clinical needs and primary indications.

IBP is a clinical approach to programming that was developed based on physician consultation and case studies. The intent of IBP is to enhance patient outcomes and save time by providing base programming recommendations that you can customize as needed. IBP systematically presents the specific features intended for use with the clinical conditions you identify in the IBP user interface, and allows you to take maximum advantage of the pulse generator's capabilities.

IBP can be accessed from the Settings tab on the main application screen (Figure 1-2 on page 1-15).

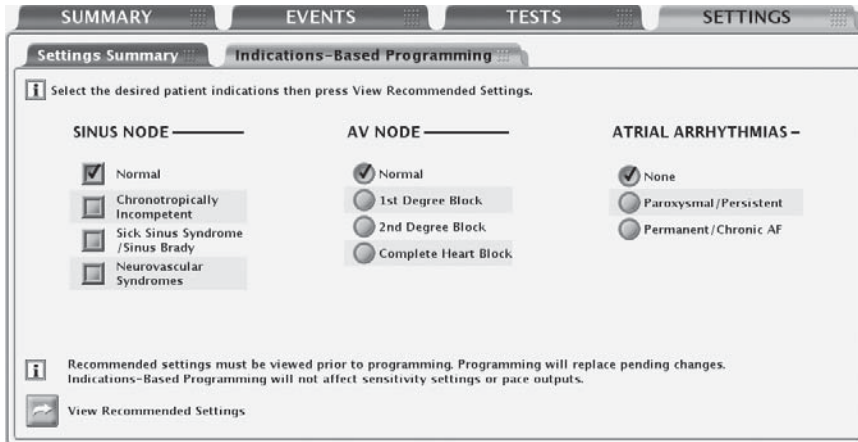

Figure 1-2. Indications-based Programming screen

Indications are clustered in general categories as illustrated above. The intent for each category of indications is described below:

- Sinus Node
    - If Normal is selected, the intent is to allow intrinsic atrial events and provide RV pacing when necessary.
    - If Chronotropically Incompetent is selected, the intent is to provide rate-adaptive pacing.
    - If Sick Sinus Syndrome is selected, the intent is to provide atrial pacing support.
    - If Neurovascular Syndromes is selected, the intent is to provide Sudden Brady Response.
  - AV Node
    - If Normal or 1st Degree Block is selected, the intent is to allow intrinsic AV conduction and provide RV pacing when necessary.
    - If 2nd Degree Block is selected, the intent is to allow intrinsic AV conduction and provide AV sequential pacing when conduction is not present.
    - If Complete Heart Block is selected, the intent is to provide AV sequential pacing.
- NOTE:** The selected settings for AF and Sinus Node may affect the suggested value for the Normal/1st Degree Block setting of AV Node.
- Atrial Arrhythmias
    - If Paroxysmal/Persistent is selected, the intent is to avoid tracking atrial arrhythmias by using ATR Mode Switch when a dual-chamber pacing mode is suggested.
    - If Permanent/Chronic AF is selected, the intent is to provide rate-adaptive RV pacing and set atrial sensing to Off.

After choosing appropriate patient indications, select the View Recommended Settings button to view a summary of the programming recommendations (Figure 1-3 on page 1-16).

**NOTE:** You must view the recommended settings before you can program them. Selecting the View Recommended Settings button allows you to view the settings that are recommended based on the indications that you selected. Viewing the recommended settings does not overwrite any pending (i.e., not yet programmed) parameter changes. You must choose to program or reject the recommended settings after viewing them. If you choose to reject the recommended settings, all of your pending settings will be restored. If you choose to program the recommended settings, any pending parameter changes will be overwritten, with the exception of sensitivity and therapy outputs, which are independent of IBP.

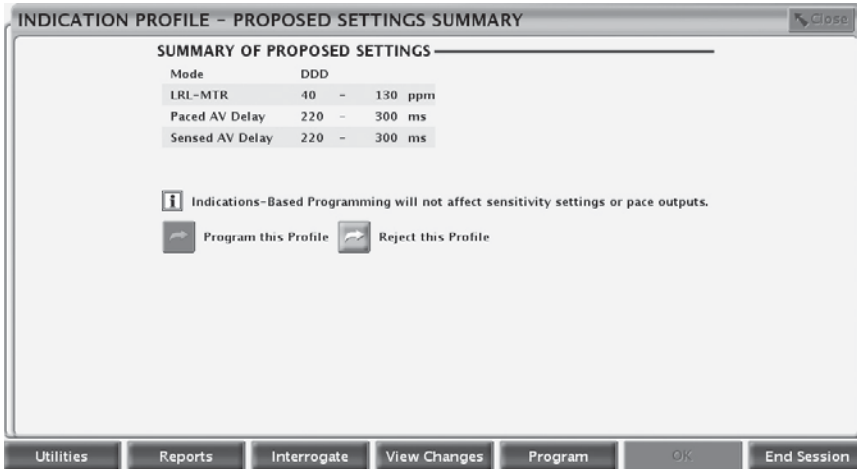

Figure 1-3. Proposed Settings Summary screen

The Proposed Settings Summary screen displays the primary programming recommendations. Additional details about all changed parameters are available by selecting the View Changes button from the toolbar. You have the option to program the proposed settings or reject them, as long as telemetry is still engaged:

- Program—select the Program this Profile button to accept the proposed settings.
- Reject—select the Reject this Profile button to reject the proposed settings; this action will return you to the main IBP screen with no changes made.

## MANUAL PROGRAMMING

Manual programming controls such as sliders and menus are available to allow you to individually adjust pulse generator program settings.

Manual programming controls are located on the Settings Summary tab, which can be accessed from the Settings tab or by selecting the Settings Summary button on the Summary tab. Refer to other feature descriptions in this manual for specific manual programming information and instructions. Refer to "Programmable Options" on page A-1 for detailed listings of available settings.

## DIVERT THERAPY

This feature is available in ACCOLADE, PROPONENT, ESSENTIO, ALTRUA 2, FORMIO, VITALIO, INGENIO, and ADVANTIO devices.

The DIVERT THERAPY key can be used to terminate any diagnostic test in progress, as well as Electrocautery Protection Mode (if using wanded telemetry, maintain the telemetry wand position until the divert function is complete to avoid interruption to the divert command).

The DIVERT THERAPY key can also be used to terminate MRI Protection Mode.

## STAT PACE

This feature is available in ACCOLADE, PROPONENT, ESSENTIO, ALTRUA 2, FORMIO, VITALIO, INGENIO, and ADVANTIO devices.

Emergency bradycardia pacing using the STAT PACE command sets the bradycardia operation to parameters intended to ensure capture.

1. If you are not already in a session, position the telemetry wand within range of the pulse generator.
2. Press the STAT PACE key. A message window displays the STAT PACE values.
3. Press the STAT PACE key a second time. A message indicates that STAT PACE is being performed, followed by the STAT PACE values.
4. Select the Close button on the message window.
5. To stop STAT PACE, reprogram the pulse generator.

**NOTE:** STAT PACE will terminate Electrocautery Protection Mode and MRI Protection Mode.

**CAUTION:** When a pulse generator is programmed to STAT PACE settings, it will continue to pace at the high-energy STAT PACE values if it is not reprogrammed. The use of STAT PACE parameters will likely decrease device longevity.

The STAT PACE parameter values are listed below (Table 1-2 on page 1-17).

**Table 1-2. STAT PACE Parameter Values**

Parameter	Values
Mode	VVI
Lower Rate Limit	60 ppm
Interval	1000 ms
Amplitude	7.5 V
Pulse Width	1.0 ms
Paced Refractory	250 ms
Lead Configuration (Pace/Sense)	Unipolar

**NOTE:** STAT PACE pacing mode is AAI for single-chamber devices programmed to AAI(R) or AOO.

## DATA MANAGEMENT

The PRM system allows you to view, print, store, or retrieve patient and pulse generator data. This section describes the PRM data management capabilities.

## Patient Information

This feature is available in ACCOLADE, PROPONENT, ESSENTIO, ALTRUA 2, FORMIO, VITALIO, INGENIO, and ADVANTIO devices.

Information about the patient can be stored in pulse generator memory. The information is accessible from the Summary screen by selecting the Patient icon. This information includes, but is not limited to, the following:

- Patient and physician data
- Pulse generator serial number
- Implant date
- Lead configurations
- Implant test measurements

The information can be retrieved at any time by interrogating the pulse generator and viewing it on the PRM screen or printing it as a report.

**NOTE:** *If the data for patient date of birth, gender, or fitness level are changed within Patient Information, the corresponding value in Minute Ventilation will automatically change. Likewise, if the data for fitness level is changed within Minute Ventilation, the corresponding value in Patient Information will automatically change.*

## Data Storage

This feature is available in ACCOLADE, PROPONENT, ESSENTIO, ALTRUA 2, FORMIO, VITALIO, INGENIO, and ADVANTIO devices.

The PRM system allows you to save pulse generator data to the PRM hard drive or a removable floppy data disk. Data saved to the PRM can also be transferred to a removable USB pen drive.

Saved pulse generator data includes, but is not limited to, the following:

- Therapy history
- Programmed parameter values
- Trending values
- HRV
- Histogram paced/sensed counters

Select the Utilities button, and then select the Data Storage tab to access the following options:

- Read Disk—allows you to retrieve saved pulse generator data from a floppy disk.
- Save All—allows you to save pulse generator data to either a floppy disk (disk must be inserted) or the PRM hard drive (if no floppy disk is detected). Data saved to a floppy disk can be retrieved using the Read Disk option described above. Data saved to the PRM can be read, deleted, or exported to a USB pen drive from the PRM startup screen. Reports are available in PDF format. Refer to the PRM Operator's Manual for more information.

**NOTE:** *While the data is being saved, a message on the right-hand side of the System Status screen indicates where the data is being saved.*

Boston Scientific Confidential. Unauthorized use is prohibited.

LIT APPROVAL - INGENIO 1-2 MRI REF GUIDE US



Consider the following when storing and retrieving pulse generator data:

- No more than 400 unique patient records may be saved to the PRM. When a pulse generator is interrogated, the PRM evaluates if there is already a record on file for this pulse generator, or if a new record will need to be created. If a new record is needed, and the PRM is at the 400 record capacity, the oldest record on file will be deleted to create space for the new patient record.
- When performing multiple patient checkups, be sure to start a new session for each patient.
- Be sure to save all pulse generator data to either a floppy disk or USB pen drive before returning a PRM to Boston Scientific, as all patient and pulse generator data will be erased from the PRM when it is returned.
- To protect patient privacy, pulse generator data can be encrypted before it is transferred to a USB pen drive.

## Device Memory

This feature is available in ACCOLADE, PROPONENT, ESSENTIO, ALTRUA 2, FORMIO, VITALIO, INGENIO, and ADVANTIO devices.

The Device Memory utility allows you to retrieve, save, and print pulse generator memory data, which is intended for use by a Boston Scientific representative for clinical and troubleshooting purposes. This utility should only be used when directed by a Boston Scientific representative. Digital media with device memory data contains protected health information and therefore should be handled in accordance with applicable privacy and security policies and regulations.

**NOTE:** Use the Data Storage tab to access pulse generator data for clinician use ("Data Storage" on page 1-18).

## Print

You can print PRM reports by using the internal printer, or by connecting to an external printer. To print a report, select the Reports button. Then select the report you wish to print from the following categories:

- Follow-up reports
- Episode reports
- Other reports (includes device settings, patient data, and other information)

## SAFETY MODE

This feature is available in ACCOLADE, PROPONENT, ESSENTIO, ALTRUA 2, FORMIO, VITALIO, INGENIO, and ADVANTIO devices.

The pulse generator is equipped with dedicated Safety Core hardware that is intended to provide life-sustaining therapy if certain nonrecoverable or repeat fault conditions occur and cause a system reset. These types of faults indicate a loss of component integrity in the pulse generator's central processing unit (CPU), including the microprocessor, program code, and system memory. Using minimal hardware (i.e., unipolar lead configuration), Safety Core operates independently and acts as a backup to these components.

Safety Core also monitors the device during normal pacing; if normal pacing does not occur, Safety Core delivers an escape pace, and a system reset is initiated.

If the pulse generator experiences three resets within approximately 48 hours, the device reverts to Safety Mode and device replacement should be considered. The following will also occur:

- ZIP telemetry is unavailable for communicating with the PRM when Safety Mode is active; wanded telemetry must be used instead.
- LATITUDE NXT will alert that Safety Mode has been activated.
- Upon interrogation, a warning screen is displayed indicating that the pulse generator is in Safety Mode, and directing you to contact Boston Scientific.

## Backup Pacemaker

Safety Mode provides ventricular pacing, with the following parameters:

**NOTE:** For single-chamber pacemakers, Safety Mode does not distinguish between lead positions. Pacing therapy is provided with the parameters listed below regardless of whether the lead is placed in the atrium or ventricle. Additionally, if the lead is placed in the right atrium, the Safety Mode screen will still indicate that ventricular therapy is being provided. For dual-chamber pacemakers, Safety Mode pacing is provided in the ventricle only.

- Brady Mode—VVI
- LRL—72.5 ppm
- Pulse Amplitude—5.0 V
- Pulse Width—1.0 ms
- RV Refractory Period (RVRP)—250 ms
- RV Sensitivity—AGC 0.25 mV
- RV lead configuration—Unipolar
- Noise Response—VOO

**NOTE:** Safety Mode also disables Magnet Response.

**WARNING:** If the pulse generator enters Safety Mode from MRI Protection Mode, backup pacing will not occur in the following scenarios:

- if a functional bipolar ventricular pacing lead is not present
- if the Pacing Mode under MRI Protection Mode settings is programmed to Off; the pulse generator will continue permanently with the Pacing Mode programmed to Off, and the patient will not receive pacing therapy until the pulse generator is replaced

**CAUTION:** Consider that the following backup pacing parameters will be different from normal Safety Mode operation if the pulse generator was in MRI Protection Mode (with Pacing Mode set to a value other than Off) when it reverted to Safety Mode:

- Brady Mode—VOO
- RV Lead Configuration—Bipolar
- RV Refractory Period (RVRP)—not applicable due to asynchronous pacing
- RV Sensitivity—not applicable due to asynchronous pacing
- Noise Response—not applicable due to asynchronous pacing

Boston Scientific Confidential. Unauthorized use is prohibited.

**LIT APPROVAL - INGENIO 1-2 MRI REF GUIDE US**

# PACING THERAPIES

---

## CHAPTER 2

This chapter contains the following topics:

- "Pacing Therapies" on page 2-2
- "Device Modes" on page 2-2
- "Basic Parameters" on page 2-5
- "Temporary Brady Pacing" on page 2-26
- "Rate Adaptive Pacing and Sensor Trending" on page 2-26
- "Atrial Tachy Response" on page 2-43
- "Rate Enhancements" on page 2-48
- "Lead Configuration" on page 2-54
- "AV Delay" on page 2-57
- "Refractory" on page 2-62
- "Noise Response" on page 2-69

## PACING THERAPIES

The bradycardia pacing function is independent of the tachycardia detection function of the device, with the exception of interval-to-interval sensing.

Single and dual-chamber pacemakers provide atrial and/or ventricular sensing and pacing, including adaptive-rate modes.

The pulse generator provides the following types of therapies:

### Normal Bradycardia Pacing

- If the intrinsic heart rate falls below the programmed pacing rate (i.e., LRL), the device delivers pacing pulses at the programmed settings.
- Adaptive-rate pacing allows the pulse generator to adapt the pacing rate to the patient's changing activity levels and/or physiologic needs.

### Additional Options

- Temporary Bradycardia Pacing—allows the clinician to examine alternate therapies while maintaining the previously programmed normal pacing settings in the pulse generator memory ("Temporary Brady Pacing" on page 2-26).
- STAT PACE—initiates emergency ventricular pacing at high output settings when commanded via the PRM using telemetry communication ("STAT PACE" on page 1-17).
- Electrocautery Protection—provides asynchronous pacing at the programmed outputs and LRL when commanded by the programmer ("Electrocautery Protection Mode" on page 2-3).
- MRI Protection—modifies certain pulse generator functions in order to mitigate risks associated with exposing the pacing system to the MRI environment ("MRI Protection Mode" on page 2-3).

## DEVICE MODES

Once the pulse generator has been programmed out of Storage Mode, the following device modes are available:

- Brady Therapy Enabled—indicates that the pulse generator is providing normal pacing therapy. This mode is not selectable; it is set automatically so long as Brady Mode is programmed to anything except Off.
- Brady Therapy Off—indicates that the pulse generator is not providing any therapy. This mode is not selectable; it is set automatically when the Brady Mode is programmed to Off.
- Electrocautery Protection Mode—provides asynchronous pacing at the programmed outputs and LRL when commanded by the programmer. This mode is enabled via the Device Mode button.
- MRI Protection Mode—modifies certain pulse generator functions in order to mitigate risks associated with exposing the pacing system to the MRI environment. This mode is enabled via the Device Mode button.
- Safety Mode—automatically activated by the pulse generator when it experiences a nonrecoverable fault. This mode is not selectable ("Safety Mode" on page 1-19).

Boston Scientific Confidential. Unauthorized use is prohibited.

LIT APPROVAL - INGENIO 1-2 MRI REF GUIDE US

## Electrocautery Protection Mode

This feature is available in ACCOLADE, PROPONENT, ESSENTIO, ALTRUA 2, FORMIO, VITALIO, INGENIO, and ADVANTIO devices.

Electrocautery Protection Mode provides asynchronous pacing at the programmed outputs and LRL. Tachyarrhythmia detection is deactivated.

When Electrocautery Protection is enabled, the Brady Mode switches to an XOO mode (where X is determined by the programmed Brady Mode). Other pacing parameters remain at the programmed settings (including pacing output). If Brady Mode is Off prior to enabling Electrocautery Protection, it will remain Off during Electrocautery Protection. Once enabled, Electrocautery Protection does not require constant telemetry to remain active.

After cancelling Electrocautery Protection, the Brady Mode will revert to the previously programmed setting.

After attempting to enable Electrocautery Protection Mode, refer to the message on the PRM screen confirming that Electrocautery Protection is active.

Except for STAT PACE, no commanded therapies, diagnostic tests, or printing of reports will be allowed while Electrocautery Protection is enabled.

Application of a magnet while the device is in Electrocautery Protection has no effect on pacing rate.

To enable and disable Electrocautery Protection Mode, perform the following steps:

1. Select the Device Mode button from the top of the PRM screen.
2. Select the check box to Enable Electrocautery Protection.
3. Select the Apply Changes button to enable Electrocautery Protection Mode. A dialog window will appear, indicating that Electrocautery Protection is active.
4. Select the Cancel Electrocautery Protection button on the dialog window to return the device to the previously programmed mode. Electrocautery Protection can also be cancelled by pressing the STAT PACE or DIVERT THERAPY key on the PRM.

## MRI Protection Mode

This feature is available in ACCOLADE MRI, PROPONENT MRI, ESSENTIO MRI, FORMIO MRI, VITALIO MRI, and INGENIO MRI devices.

For a complete description of MRI Protection Mode, as well as additional information about the ImageReady MR Conditional Pacing System, refer to the ImageReady MR Conditional Pacing System MRI Technical Guide.

**WARNING:** Unless all of the MRI Conditions of Use are met, MRI scanning of the patient does not meet MR Conditional requirements for the implanted system, and significant harm to or death of the patient and/or damage to the implanted system may result.

For additional warnings, precautions, Conditions of Use, and potential adverse events applicable when the Conditions of Use are met or not met, refer to the MRI Technical Guide.

Boston Scientific Confidential. Unauthorized use is prohibited.

LIT APPROVAL - INGENIO 1-2 MRI REF GUIDE US

MRI Protection Mode provides asynchronous pacing (or pacing Off) with the following fixed and programmable parameters:

- Pacing mode options include asynchronous pacing or no pacing (DOO, AOO, VOO, or Off).
- The Lower Rate Limit is nominally set to 20 ppm above the starting LRL, and is programmable in normal increments. For both the nominal setting based on the LRL and the programmable setting, the maximum value is 100 ppm.
- Atrial pulse amplitude and ventricular pulse amplitude are nominally set to 5.0 V and are programmable in normal increments between 2.0 V and 5.0 V.
- AV Delay is fixed at 100 ms
- Pulse Width is fixed at 1.0 ms for both chambers
- A Time-out feature is nominally set to 24 hours, with programmable values of Off, 12, 24, and 48 hours

When MRI Protection Mode is active, the following features and functions are suspended:

- PaceSafe RV Automatic Capture
- PaceSafe RA Automatic Threshold
- Cardiac sensing
- Daily diagnostics (Lead Impedance, Intrinsic Amplitude, Pace Threshold)
- Motion and respiratory sensors
- Magnet Response
- ZIP Telemetry
- Battery voltage monitoring

The following device conditions will preclude the user from having the option to enter MRI Protection Mode:

- Battery capacity status is Depleted
- Pulse generator is in Storage Mode
- Pulse generator is in Electrocautery Protection Mode
- Pulse generator is in Safety Core operation (Safety Mode)
- Diagnostic test is in progress
- EP Test is in progress



Certain conditions in the pulse generator and/or system will cause a user request to enter MRI Protection Mode to be rejected. These include:

- A ventricular episode as detected and recognized by the pulse generator is in progress
- Magnet presence is detected by the magnet sensor
- Pulse generator is in STAT PACE mode
- Unipolar pacing configuration in chamber(s) where pacing will occur in MRI Protection Mode

MRI Protection Mode is terminated by manual exit or by setting a user-programmed automatic Time-out period (refer to the MRI Technical Guide for MRI Protection Mode programming instructions). STAT PACE and DIVERT THERAPY will also terminate MRI Protection Mode.

MRI Protection Mode is accessed via the Device Mode button. Choosing MRI Protection Mode will initiate a sequence of dialog boxes to assess the eligibility and readiness of the patient and the patient's pacing system to undergo an MR Conditional MRI scan. Detailed programming instructions, the Conditions for Use, and a comprehensive list of MRI-related warnings and precautions are provided in the MRI Technical Guide.

## BASIC PARAMETERS

Normal Settings include the following:

- Pacing parameters, which are independently programmable from temporary pacing parameters
- Pacing and Sensing
- Leads
- Rate Adaptive Pacing and Sensor Trending

### Interactive Limits

Because many features with programmable parameters interact, programmed values must be compatible across such features. When values requested by the user are incompatible with existing parameters, the programmer screen displays an alert describing the incompatibility and either prohibits the selection or instructs the user to proceed with caution ("Use of Color" on page 1-7).

## Brady Mode

This feature is available in ACCOLADE, PROPONENT, ESSENTIO, ALTRUA 2, FORMIO, VITALIO, INGENIO, and ADVANTIO devices.

Brady modes provide programmable options to help individualize patient therapy.

### DDD and DDDR

In the absence of sensed P- and R-waves, pacing pulses will be delivered to the atrium and the ventricle at the LRL (DDD) or the sensor-indicated rate (DDDR), separated by the AV Delay. A sensed P-wave will inhibit an atrial pace and start the AV Delay. At the end of the AV Delay, a ventricular pace will be delivered unless inhibited by a sensed R-wave.

### DDI and DDIR

In the absence of sensed P- and R-waves, pacing pulses will be delivered to the atrium and the ventricle at the LRL (DDI) or the sensor-indicated rate (DDIR), separated by the AV Delay. A sensed P-wave will inhibit an atrial pace but will not start the AV Delay.

### VDD and VDDR

In the absence of sensed P- and R-waves, pacing pulses will be delivered to the ventricle at the LRL (VDD) or the sensor-indicated rate (VDDR). A sensed P-wave will start the AV Delay. At the end of the AV Delay, a ventricular pace will be delivered unless inhibited by a sensed R-wave. A sensed R-wave or a paced ventricular event will determine the timing of the next ventricular pace.

### VVI and VVIR

In VVI(R) mode, sensing and pacing occur only in the ventricle. In the absence of sensed events, pacing pulses will be delivered to the ventricle at the LRL (VVI) or the sensor-indicated rate (VVIR). A sensed R-wave or a paced ventricular event will determine the timing of the next ventricular pace.

### AAI and AAIR

In AAI(R) mode, sensing and pacing occur only in the atrium. In the absence of sensed events, pacing pulses will be delivered to the atrium at the LRL (AAI) or the sensor-indicated rate (AAIR). A sensed P-wave or a paced atrial event will determine the timing of the next atrial pace.

### DOO

Pacing pulses will be delivered asynchronously to the atrium and the ventricle at the LRL, separated by the AV Delay. Intrinsic events will neither inhibit nor trigger pacing in either chamber.

**NOTE:** DOO mode is the magnet mode of DDD(R) and DDI(R) modes.

- May be used intraoperatively to reduce the likelihood of inhibition when sources of conducted electrical current are present

**NOTE:** Electrocautery Protection Mode is the preferred option if available.

### VOO

Pacing pulses will be delivered asynchronously to the ventricle at the LRL. Intrinsic events will neither inhibit nor trigger pacing in the ventricle.

**NOTE:** VOO mode is the magnet mode of VVI(R) and VDD(R) modes.

- May be used intraoperatively to reduce the likelihood of inhibition when sources of conducted electrical current are present

**NOTE:** *Electrocautery Protection Mode is the preferred option if available.*

## **AOO**

Pacing pulses will be delivered asynchronously to the atrium at the LRL. Intrinsic events will neither inhibit nor trigger pacing in the atrium.

**NOTE:** *AOO mode is the magnet mode of AAI(R) mode.*

- May be used intraoperatively to reduce the likelihood of inhibition when sources of conducted electrical current are present

**NOTE:** *Electrocautery Protection Mode is the preferred option if available.*

## **Single-Chamber Modes**

Single-chamber pulse generators may be programmed to VVI(R), AAI(R), VOO or AOO mode to specify the lead position.

**NOTE:** *If a lead position is specified on the Patient Information screen, the Brady Mode must comply with that lead position.*

Some features may behave differently or become unavailable under the following circumstances:

- In a dual-chamber device programmed to a single-chamber mode
- In a single-chamber device programmed to AAI(R)

## **Dual-Chamber Modes**

Do not use DDD(R) and VDD(R) modes in the following situations:

- In patients with chronic refractory atrial tachyarrhythmias (atrial fibrillation or flutter), which may trigger ventricular pacing
- In the presence of slow retrograde conduction that induces PMT, which cannot be controlled by reprogramming selective parameter values

## **Atrial Pacing Modes**

In DDD(R), DDI(R), AAI(R), DOO, and AOO modes, atrial pacing may be ineffective in the presence of chronic atrial fibrillation or flutter or in an atrium that does not respond to electrical stimulation. In addition, the presence of clinically significant conduction disturbances may contraindicate the use of atrial pacing.

The following graphic may be used to assist in determining the most appropriate mode for a specific patient.

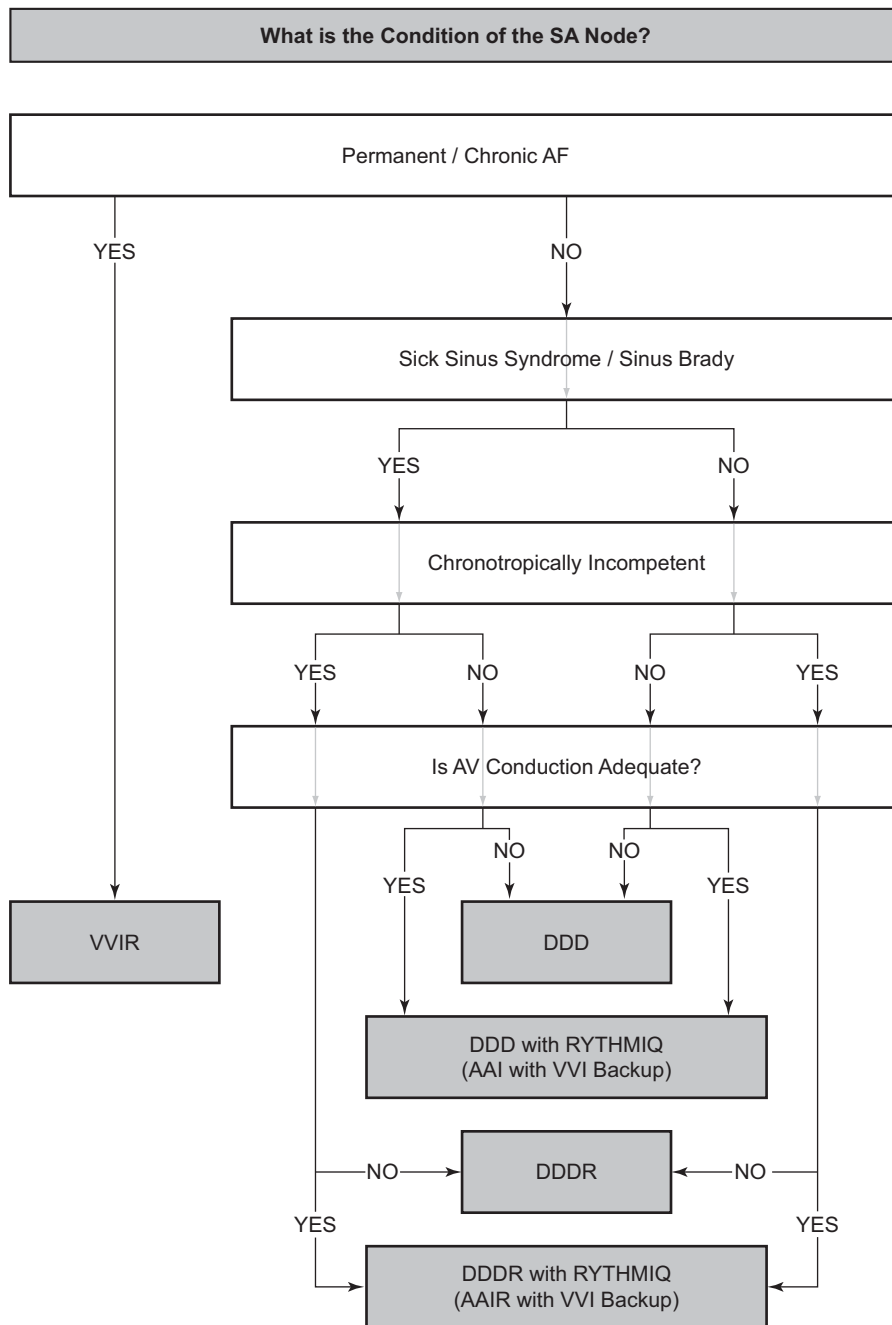

Figure 2-1. Optimal pacing mode decision tree

**WARNING:** Do not use atrial tracking modes in patients with chronic refractory atrial tachyarrhythmias. Tracking of atrial arrhythmias could result in ventricular tachyarrhythmias.

**CAUTION:** If a dual-chamber device is programmed to AAI(R), ensure that a functional RV lead is present. In the absence of a functional RV lead, programming to AAI(R) may result in undersensing or oversensing.

If you have any questions regarding the individualization of patient therapy, contact Boston Scientific using the information on the back cover.

## Lower Rate Limit (LRL)

This feature is available in ACCOLADE, PROPONENT, ESSENTIO, ALTRUA 2, FORMIO, VITALIO, INGENIO, and ADVANTIO devices.

LRL is the number of pulses per minute at which the pulse generator paces in the absence of sensed intrinsic activity.

As long as the ventricle is being paced (or if a PVC occurs), the interval is timed from one ventricular event to the next. Whenever an event is sensed in the ventricle (e.g., intrinsic AV conduction occurs before the AV Delay elapses), the timing base switches from ventricular-based timing to modified atrial-based timing (Figure 2-2 on page 2-9). This switching of timing base ensures accurate pacing rates since the difference between the intrinsic AV conduction and programmed AV Delay is applied to the next V–A interval.

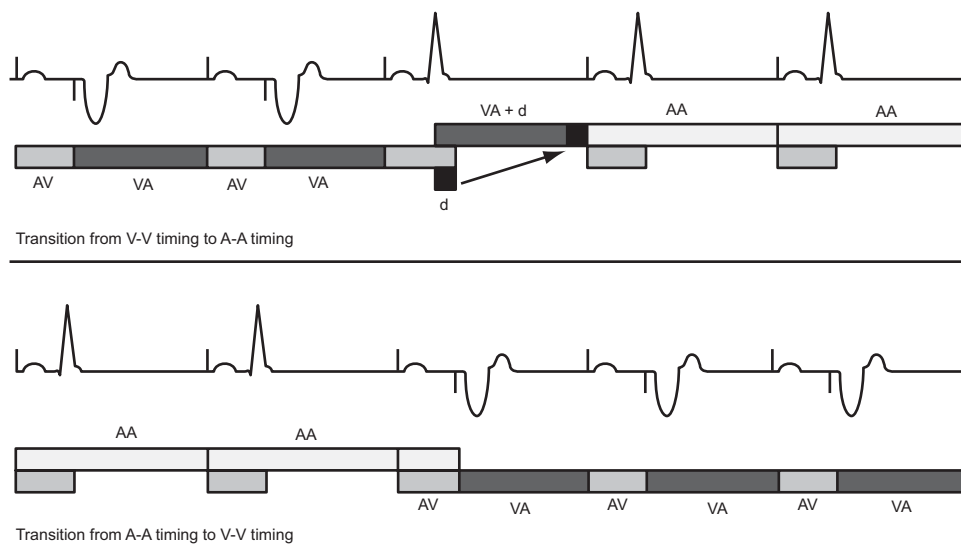

Illustration of timing transitions ( $d$  = the difference between AV Delay and the AV interval in the first cycle during which intrinsic conduction occurs. The value of  $d$  is applied to the next V–A interval to provide a smooth transition without affecting A–A intervals).

**Figure 2-2. LRL timing transitions**

## Maximum Tracking Rate (MTR)

This feature is available in ACCOLADE, PROPONENT, ESSENTIO, ALTRUA 2, FORMIO, VITALIO, INGENIO, and ADVANTIO devices.

The MTR is the maximum rate at which the paced ventricular rate tracks 1:1 with nonrefractory sensed atrial events in the absence of a sensed ventricular event within the programmed AV Delay. MTR applies to atrial synchronous pacing modes, namely DDD(R) and VDD(R).

Consider the following when programming MTR:

- The patient's condition, age, and general health
- The patient's sinus node function

Boston Scientific Confidential. Unauthorized use is prohibited.

LIT APPROVAL - INGENIO 1-2 MRI REF GUIDE US

- A high MTR may be inappropriate for patients who experience angina or other symptoms of myocardial ischemia at higher rates

**NOTE:** *If the pulse generator is operating in DDDR or VDDR mode, the MSR and MTR may be programmed independently to different values.*

### Upper Rate Behavior

When the sensed atrial rate is between the programmed LRL and MTR, 1:1 ventricular pacing will occur in the absence of a sensed ventricular event within the programmed AV Delay. If the sensed atrial rate exceeds the MTR, the pulse generator begins a Wenckebach-like behavior to prevent the paced ventricular rate from exceeding the MTR. This Wenckebach-like behavior is characterized by a progressive lengthening of the AV Delay until an occasional P-wave is not tracked because it falls into the PVARP. This results in an occasional loss of 1:1 tracking as the pulse generator synchronizes its paced ventricular rate to the next sensed P-wave. Should the sensed atrial rate continue to increase further above the MTR, the ratio of sensed atrial events to sequentially paced ventricular events becomes lower until, eventually, 2:1 block results (e.g., 5:4, 4:3, 3:2, and finally 2:1).

The sensing window should be maximized by programming the appropriate AV Delay and PVARP. At rates close to the MTR, the sensing window can be maximized by programming Dynamic AV Delay and Dynamic PVARP, and Wenckebach behavior will be minimized.

High rate atrial tracking is limited by the programmed MTR and the total atrial refractory period (TARP) (AV Delay + PVARP = TARP). In order to avoid complete closure of the sensing window at MTR, the PRM will not allow a TARP interval that is longer (lower pacing rate) than the programmed MTR interval.

If the TARP interval is shorter (higher pacing rate) than the interval of the programmed MTR, then the pulse generator's Wenckebach-like behavior limits the ventricular pacing rate to the MTR. If the TARP interval is equal to the interval of the programmed MTR, 2:1 block may occur with atrial rates above the MTR.

The PRM does not consider the AV Delay associated with AV Search + when calculating the TARP interval ("AV Search +" on page 2-60).

Rapid changes in the paced ventricular rate (e.g., Wenckebach-like, 2:1 block) caused by sensed atrial rates above the MTR may be dampened or eliminated by the implementation of any of the following:

- AFR
- ATR
- Rate Smoothing parameters and sensor input

**NOTE:** *For the purpose of atrial tachycardia detection and histogram updates, atrial events are detected throughout the cardiac cycle (except during atrial blanking), including AV Delay and PVARP.*

### Examples

If the atrial rate exceeds the MTR, the AV Delay will be progressively lengthened (AV') until an occasional P-wave is not tracked because it falls into the atrial refractory period (Figure 2-3 on page 2-11). This results in occasional loss of 1:1 tracking as the pulse generator synchronizes its paced ventricular rate to the next tracked P-wave (pacemaker Wenckebach).

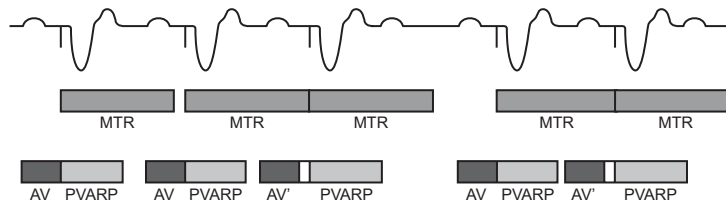

**Figure 2-3. Wenckebach behavior at MTR**

Another type of pulse generator upper rate behavior (2:1 block) can occur when tracking high atrial rates. In this type of behavior, every other intrinsic atrial event occurs during PVARP and, thus, is not tracked (Figure 2-4 on page 2-11). This results in a 2:1 ratio of atrial-to-ventricular events or a sudden drop in the ventricular paced rate to half of the atrial rate. At faster atrial rates, several atrial events can fall in the TARP period, resulting in the pulse generator tracking only every third or fourth P-wave. The block then occurs at rates such as 3:1 or 4:1.

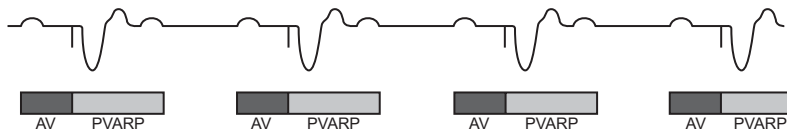

Illustration of pacemaker 2:1 block, in which every other P-wave falls inside the PVARP interval.

**Figure 2-4. Pacemaker 2:1 block**

## Maximum Sensor Rate (MSR)

This feature is available in ACCOLADE, PROPONENT, ESSENTIO, ALTRUA 2, FORMIO, VITALIO, INGENIO, and ADVANTIO devices.

MSR is the maximum pacing rate allowed as a result of rate-adaptive sensor control.

Consider the following when programming MSR:

- Patient's condition, age, and general health:
  - Adaptive-rate pacing at higher rates may be inappropriate for patients who experience angina or other symptoms of myocardial ischemia at these higher rates
  - An appropriate MSR should be selected based on an assessment of the highest pacing rate that the patient can tolerate well

**NOTE:** If the pulse generator is operating in DDDR or VDDR mode, the MSR and MTR may be programmed independently to different values.

MSR is independently programmable at, above, or below the MTR. If the MSR setting is higher than the MTR, pacing above the MTR may occur if the sensor rate exceeds the MTR.

Pacing above the MSR (when programmed lower than the MTR) can only occur in response to sensed intrinsic atrial activity.

**CAUTION:** Adaptive-rate pacing is not limited by refractory periods. A long refractory period programmed in combination with a high MSR can result in asynchronous pacing during refractory periods since the combination can cause a very small sensing window or none at all. Use Dynamic AV Delay or Dynamic PVARP to optimize sensing windows. If you are programming a fixed AV Delay, consider the sensing outcomes.

With intrinsic conduction, the pulse generator maintains the A–A pacing rate by extending the V–A interval. This extension is determined by the degree of difference between the AV Delay and the intrinsic ventricular conduction—often referred to as modified atrial-based timing (Figure 2-5 on page 2-12).

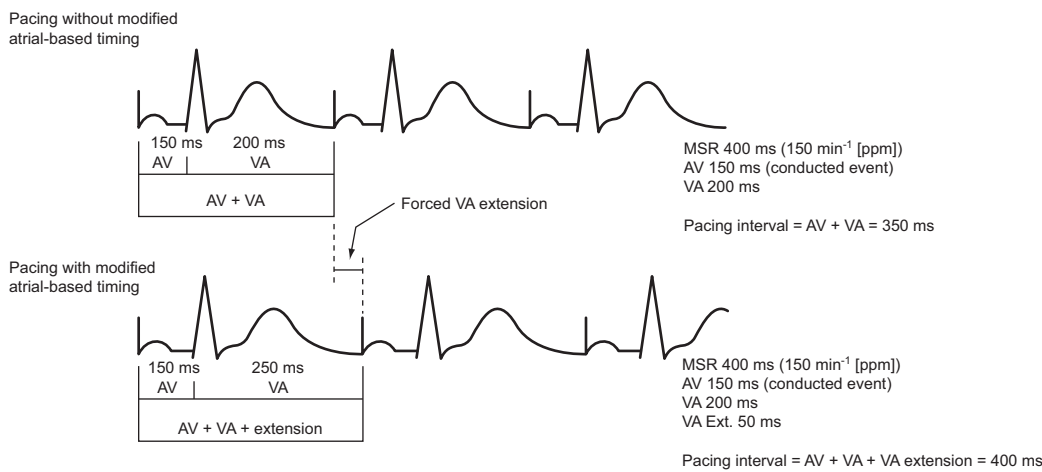

The pulse generator's timing algorithm provides effective pacing at the MSR with intrinsic ventricular conduction. Extending the VA interval prevents the A pace from exceeding the MSR at high rates.

**Figure 2-5. VA interval extension and MSR**

## Runaway Protection

Runaway protection is designed to prevent pacing rate accelerations above the MTR/MSR for most single-component failures. This feature is not programmable and operates independently from the pulse generator's main pacing circuitry.

Runaway protection prevents the pacing rate from increasing above 205 ppm.

**NOTE:** Runaway protection is not an absolute assurance that runaways will not occur.

During PES and Manual Burst Pacing, runaway protection is temporarily suspended to allow for high-rate pacing.

## Pulse Width

This feature is available in ACCOLADE, PROPONENT, ESSENTIO, ALTRUA 2, FORMIO, VITALIO, INGENIO, and ADVANTIO devices.

Pulse Width, also referred to as pulse duration, determines how long the output pulse will be applied between the pacing electrodes.



Consider the following when programming Pulse Width:

- Pulse Widths are independently programmable for each chamber.
- If a Pulse Width Threshold Test is performed, a minimum 3X pulse width safety margin is recommended.
- The energy delivered to the heart is directly proportional to the Pulse Width; doubling the Pulse Width doubles the energy delivered. Therefore, programming a shorter Pulse Width while maintaining an adequate safety margin may increase battery longevity. To prevent loss of capture, exercise caution when you are programming permanent Pulse Width values of less than 0.3 ms (Figure 2-6 on page 2-13).

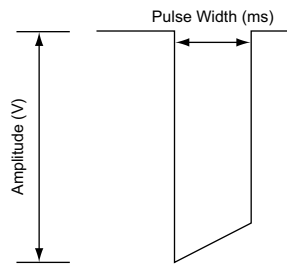

Figure 2-6. Pulse waveform

## Amplitude

This feature is available in ACCOLADE, PROPONENT, ESSENTIO, ALTRUA 2, FORMIO, VITALIO, INGENIO, and ADVANTIO devices.

The pulse amplitude, or voltage of the output pulse, is measured at the leading edge of the output pulse (Figure 2-6 on page 2-13).

Consider the following when programming Amplitude:

- Amplitudes are independently programmable for each chamber.
- Brady Mode may be programmed to Off via permanent or temporary programming. In effect, this turns Amplitude Off to monitor the patient's underlying rhythm.
- A minimum 2X voltage safety margin is recommended for each chamber based on the capture thresholds. If PaceSafe is programmed On, it will automatically provide an adequate safety margin and may help extend battery longevity.
- The energy delivered to the heart is directly proportional to the square of the amplitude: doubling the amplitude quadruples the energy delivered. Therefore, programming to a lower Amplitude while maintaining an adequate safety margin may increase battery longevity.

## PaceSafe

### PaceSafe Right Atrial Automatic Threshold (RAAT)

This feature is available in ACCOLADE, PROPONENT, ESSENTIO, ALTRUA 2, FORMIO, and VITALIO devices.

Boston Scientific Confidential. Unauthorized use is prohibited.

LIT APPROVAL - INGENIO 1-2 MRI REF GUIDE US

PaceSafe RAAT is designed to dynamically adjust the atrial pacing output to ensure capture of the atrium by optimizing the output voltage to a 2X safety margin (for thresholds less than or equal to 2.5V). RAAT will measure pacing thresholds between 0.2 V and 4.0 V at 0.4 ms and the output will be a minimum of 2.0 V and a maximum of 5.0 V with a fixed pulse width of 0.4 ms.

**NOTE:** *To function properly, RAAT requires a functional RV lead and a bipolar atrial lead. It is important to indicate on the Patient Information screen that a bipolar lead is present, particularly if the Atrial Pace and Sense Lead Configurations are programmed to Unipolar.*

**NOTE:** *RAAT is only available in pulse generators programmed to DDD(R) and DDI(R) modes as well as DDI(R) Fallback Mode.*

RAAT can be programmed on by selecting Auto from the Atrial Amplitude parameter options. Programming the atrial output to Auto will automatically adjust the Pulse Width to 0.4 ms and set the atrial voltage output to an initial value of 5.0 V unless there is a successful test result within the last 24 hours.

**NOTE:** *Prior to programming RAAT on, consider performing a Commanded Atrial Automatic Threshold Measurement to verify that the feature functions as expected. RAAT testing is performed in a unipolar configuration and there may be a discrepancy between unipolar and bipolar thresholds. If the bipolar threshold is greater than the unipolar threshold by more than 0.5 V, consider programming a fixed Atrial Amplitude or programming the Atrial Pace Lead Configuration to Unipolar.*

RAAT is designed to work with typical lead implant criteria and an atrial threshold between 0.2 V and 4.0 V at 0.4 ms.

The RAAT algorithm then measures the atrial pacing threshold each day and adjusts the voltage output. During testing, RAAT measures an evoked response signal to confirm that each atrial pacing output captures the atrium. If the device is unable to repeatedly measure an evoked response signal of sufficient amplitude, a “Low ER” or “Noise” message may be displayed and the algorithm will default to 5.0 V pacing amplitude. Consider programming a fixed atrial pacing amplitude in these situations and re-check with a Commanded RAAT test at a later follow-up; maturation of the lead-tissue interface may improve the performance of RAAT.

If testing is successful, the Atrial Amplitude is adjusted to 2X the highest measured threshold of the last 7 successful ambulatory tests (output Amplitude between 2.0 V and 5.0 V). Seven tests are used to account for circadian cycle effects on threshold and ensure an adequate safety margin. This also allows for a rapid increase in output due to a sudden rise in threshold while requiring consistently lower threshold measurements to decrease output (i.e., one low threshold measurement will not cause a decrease in output) (Figure 2-7 on page 2-15).

**NOTE:** *Since output is set to a 2X safety margin and RV pacing occurs shortly after atrial pacing, there is no beat-to-beat capture verification or backup atrial pacing at any time.*

When Daily Trend is selected along with a fixed Amplitude, automatic atrial threshold measurements will occur every 21 hours with no change to programmed output.

The RAAT feature is designed to operate with a large range of pacing leads (e.g., high impedance, low impedance, tined fixation, or positive fixation).

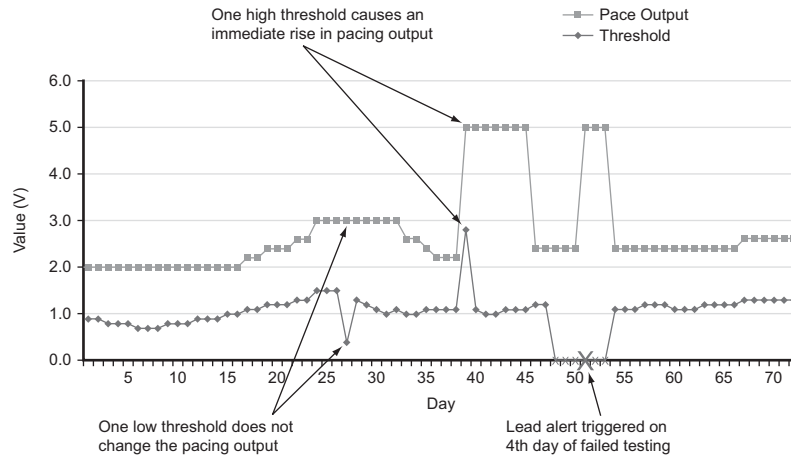

**Figure 2-7. Effect of threshold change on RAAT pacing output**

### Ambulatory Atrial Automatic Threshold Measurement

Testing uses an RA tip >> can (unipolar) pacing vector and an RA ring >> can (unipolar) sensing vector whether the lead is programmed to Unipolar or Bipolar Pace/Sense.

When RAAT is set to Auto or Daily Trend, ambulatory atrial automatic threshold measurements are conducted every 21 hours and the following parameters are adjusted to ensure a valid measurement is obtained:

- Mode remains unchanged from current mode unless RYTHMIQ is on and in AAI(R) mode; in that case the mode will switch to DDD(R) for testing.
- Starting atrial pacing amplitude is the output that RAAT is currently using. If that Amplitude value fails or if no previous results are available, the starting Amplitude is 4.0 V.
- The pacing amplitude will decrement in 0.5 V steps above 3.5 V and in 0.1 V steps at or below 3.5 V.
- Paced AV Delay is fixed at 85 ms.
- Sensed AV Delay is fixed at 55 ms.
- Initial pacing rate is set to the average atrial rate, the LRL or sensor-indicated rate, whichever is faster.
- If there are an insufficient number of atrial paces or if fusion occurs, the atrial pacing rate will be increased by 10 ppm (it may be increased a second time), but will not exceed the lowest of the MTR, MSR, MPR, 110 bpm, or 5 bpm below the VT Detection Rate.

Following initialization paces, the pulse generator will decrement the atrial output every 3 paces until a threshold is determined. If loss of capture occurs twice at a particular output level, threshold is declared as the previous output level that demonstrated consistent capture. If 3 captured beats occur at any particular output level, output decrements to the next level.

**NOTE:** To ensure that loss of capture during RAAT does not encourage PMT (and also end the test prematurely due to too many atrial senses), the pulse generator uses a PMT algorithm. Following the loss of capture of any atrial beat, the PVARP following that ventricular event is extended to 500 ms to prevent tracking of a subsequent P-wave.

If daily testing is unsuccessful, RAAT will return to the previously determined output and the pulse generator will perform up to 3 re-attempts at hourly intervals. If a successful test does not occur for 4 days, a Lead Alert will be triggered and RAAT will enter Suspension.

### Right Atrial Automatic Threshold Suspension

If ambulatory testing fails in Auto mode for 4 consecutive days, RAAT will go into a Suspension mode and the pacing output will operate at 5.0 V and 0.4 ms. Testing will continue each day with up to 3 re-attempts to evaluate thresholds and the pulse generator will adjust to a lower output setting when indicated by a successful test.

Although RAAT is designed to work with a wide range of leads, in some patients the lead signals may hinder successful determination of the atrial threshold. In these instances, RAAT will continually operate in the Suspension mode at 5.0 V. In situations where Suspension mode persists for an extended period of time, it is recommended to turn RAAT off by programming a fixed atrial output.

### Commanded Atrial Automatic Threshold Measurement

An automatic threshold measurement can be commanded via the Threshold Tests screen by selecting Auto Amplitude as the Test Type. If testing completes successfully and RAAT is programmed on, the output will automatically be set to 2X that test's measured threshold (between 2.0 V and 5.0 V). The last 7 successful daily measurements are cleared and the current commanded test result is used as the first successful test of a new 7 test cycle. This is to ensure that there will be an immediate output adjustment based on the current commanded test result rather than on older ambulatory test data. This can be confirmed by observing the output voltage on the Brady Settings screen, which will show the actual operating voltage of the RAAT algorithm.

If testing is unsuccessful, the Threshold Tests screen will display a failure code indicating the reason the test was not successful, and the output will return to the previously set level (Table 2-1 on page 2-17).

**NOTE:** For the initial Atrial Threshold test after the pulse generator is implanted, the Test Type field is seeded to Auto. Choose the desired test type from the Test Type field options, and adjust any other programmable values as appropriate.

**NOTE:** Commanded testing requires a functional bipolar atrial lead and may be performed in AAI mode.

### Test Results and Lead Alerts

A stored EGM for the most recent successful ambulatory test will be stored in the Arrhythmia Logbook ("Arrhythmia Logbook" on page 4-2). Refer to the Daily Measurements screen for the resulting threshold value. If desired, the stored EGM can be reviewed to determine where loss of capture occurred.

Up to 12 months of Ambulatory Threshold Test results, as well as test failure codes and lead alerts, can be found within the Daily Measurement and Trends screens. To provide further information on the reason for test failure, a failure code is provided for each day in which testing fails. Additionally, failure codes are provided on the Threshold Test screen if a commanded automatic threshold test does not complete successfully. Threshold Test Failure Codes are listed below (Table 2-1 on page 2-17).

Boston Scientific Confidential. Unauthorized use is prohibited.

LIT APPROVAL - INGENIO 1-2 MRI REF GUIDE US

The following scenarios will trigger the Check Atrial Lead alert:

- Threshold > Programmed Amplitude will be displayed if RAAT is in Daily Trend mode and the ambulatory test results of the last 4 consecutive days exceed the manually programmed fixed output.
- Automatic Threshold Suspension will be displayed if no successful tests are performed for 4 consecutive days in Auto or Daily Trend mode.

**Table 2-1. Threshold Test Codes**

Code	Reason
N/R: device telem.	Telemetry started during an ambulatory test
N/R: comm. lost	Telemetry was lost during a commanded test
N/R: no capture	Capture was not obtained at the starting amplitude for a commanded test or capture is > 4.0 V for an ambulatory test
N/R: mode switch	ATR mode switch either started or stopped
N/R: fusion events	Too many consecutive or too many total fusion events occurred
No data collected	Minimum pacing amplitude was reached without losing capture for an ambulatory test, or neither Auto nor Daily Trend is turned on to obtain an ambulatory result
N/R: battery low	Test was skipped due to Battery Capacity Depleted
N/R: noise	Too many consecutive sense channel noise or Evoked Response noise cycles occurred
N/R: incompat. mode	Incompatible Brady mode was present (e.g. VDI Fallback Mode, Magnet Mode) or a Lead Safety Switch occurred
N/R: rate too high	Rate was too high at the start of the test, a rate increase would raise the rate too high or more than 2 rate increases were required
N/R: user cancelled	Commanded test was stopped by the user
N/R: intrinsic beats	Too many cardiac cycles occurred during the test
N/R: test delayed	Test was delayed due to telemetry being active, VT episode already in progress, Electrocautery mode, MRI Protection Mode, or RAAT was turned on while the device remained in Storage mode
N/R: respiration	Respiratory artifact was too high
N/R: low ER	The Evoked Response signal could not be assessed adequately
Auto N/R	Minimum pacing amplitude was reached without losing capture for a commanded test, or telemetry is manually cancelled during a commanded test
Invalid Failure Code	Unexpected Failure

### **PaceSafe Right Ventricular Automatic Capture (RVAC)**

This feature is available in ACCOLADE, PROPONENT, ESSENTIO, ALTRUA 2, FORMIO, VITALIO, INGENIO, and ADVANTIO devices.

PaceSafe RVAC is designed to dynamically adjust the right ventricular pacing output to ensure capture of the ventricle by optimizing the output voltage to 0.5 V above the capture threshold. RVAC maintains this output while confirming capture on a beat-to-beat basis. RVAC will measure pacing thresholds between 0.2 V and 3.0 V at 0.4 ms, and the output will be a minimum of 0.7 V and a maximum of 3.5 V with a fixed pulse width of 0.4 ms.

**NOTE:** RVAC is intended for ventricular use only. It is not intended to be used with Amplitude programmed to Auto for single-chamber devices implanted in the atrium.

**NOTE:** RVAC is available in DDD(R), DDI(R), VDD(R), and VVI(R) modes, as well as during VDI(R) and DDI(R) Fallback Modes.

RVAC can be programmed on by selecting Auto from the Ventricular Amplitude parameter options. If starting from a fixed amplitude greater than 3.5 V, program a fixed amplitude of 3.5 V prior to selecting Auto. Programming the ventricular output to Auto will automatically adjust the Pulse Width to 0.4 ms and set the ventricular voltage output to an initial value of 5.0 V unless there is a successful test result within the last 24 hours.

RVAC must first successfully measure the ventricular threshold before it will enter its beat-to-beat capture verification mode. This measurement can be made through a commanded test, or it will be performed automatically within one hour after the programming session is completed. Both methods are described below.

**NOTE:** Prior to programming RVAC on, consider performing a Commanded Ventricular Automatic Capture Measurement to verify that the feature functions as expected.

RVAC is designed to work with typical lead implant criteria and a ventricular threshold between 0.2 V and 3.0 V at 0.4 ms.

The RVAC algorithm then measures the ventricular pacing threshold each day and adjusts the voltage output. During testing and on a beat-to-beat basis, RVAC uses an evoked response signal to confirm that each ventricular pacing output captures the ventricle.

If any loss of capture occurs during beat-to-beat operation, then the pulse generator will deliver a backup pacing output within approximately 70 ms of the primary pulse. The backup safety pulse amplitude will be a minimum of 3.5 V and a maximum of 5.0 V. If there is a Confirmed Loss of Capture (C-LOC; 2 out of 4 cardiac cycles do not capture the ventricle), RVAC will enter Suspension and a test re-attempt will occur at the next hourly interval.

When Daily Trend is selected along with a fixed Amplitude, ambulatory ventricular automatic capture measurements will occur every 21 hours with no change to programmed output.

The RVAC feature is designed to operate with a large range of pacing leads (high impedance, low impedance, tined fixation, or positive fixation). Also, RVAC is independent of pacing and sensing lead polarity; the Ventricular Pace and Sense Lead Configurations can be programmed to Unipolar or Bipolar.

For information about resumption of RVAC after exit from MRI Protection Mode, refer to the MRI Technical Guide.

### **Ambulatory Ventricular Automatic Capture Measurement**

When RVAC is set to Auto or Daily Trend, ambulatory ventricular automatic capture measurements are conducted every 21 hours, or when loss of capture is detected while in beat-to-beat mode, up to hourly until the next daily measurement.

In atrial tracking modes, the automatic capture measurement adjusts the following parameters to help ensure a valid measurement is obtained:

- Paced AV Delay is fixed at 60 ms.

Boston Scientific Confidential. Unauthorized use is prohibited.

LIT APPROVAL - INGENIO 1-2 MRI REF GUIDE US

- Sensed AV Delay is fixed at 30 ms.
- Starting ventricular pacing output amplitude is 3.5 V and will decrement in 0.1 V steps.
- A backup pulse between 3.5 V to 5.0 V is delivered approximately 70 ms after every primary pacing pulse.

In nontracking modes, the automatic capture measurement adjusts the following parameters to help ensure a valid measurement is obtained:

- Paced AV Delay is fixed at 60 ms.
- Starting ventricular pacing output amplitude is 3.5 V and will decrement in 0.1 V steps.
- A backup pulse between 3.5 V to 5.0 V is delivered approximately 70 ms after every primary pacing pulse.
- The ventricular pacing rate will be increased by 10 ppm above the current rate (paced or intrinsic) and is capped at the lowest of the MPR, MSR, 110 bpm, or 5 bpm below the VT Detection Rate.

**NOTE:** *If fusion (which could potentially be a noise beat) is detected, the AV interval and/or V–V interval may be extended on the next cardiac cycle in an attempt to distinguish the fusion beat from ventricular capture.*

Following initialization paces, the pulse generator will decrement the ventricular output every 3 paces until a threshold is determined. Additional pacing pulses will be issued if there is fusion or intermittent loss of capture. Threshold is declared as the previous output level that demonstrated consistent capture.

If daily testing is unsuccessful, RVAC will enter Suspension and perform up to 3 re-attempts at hourly intervals. If a successful test does not occur for 4 days, a Lead Alert will be triggered and RVAC will remain in Suspension.

### Right Ventricular Automatic Capture Suspension

RVAC will enter Suspension mode when any of the following occur:

- Confirmed Loss of Capture occurs in beat-to-beat capture verification mode
- Unsuccessful Ambulatory or Commanded Tests
- Battery Capacity Depleted is reached

The pacing output will operate at 2X the last measured threshold between 3.5 V and 5.0 V at 0.4 ms (Table 2-2 on page 2-19). Ambulatory testing will occur each day with up to 3 re-attempts at hourly intervals to measure the ventricular threshold. If successful, RVAC will return to the beat-to-beat mode. If a successful test does not occur for 4 days, RVAC will remain in Suspension but testing will continue each day to evaluate thresholds and the pulse generator will adjust to a lower output setting when indicated by a successful test.

**Table 2-2. Pacing output during Automatic Capture Suspension**

Last Measured Threshold (V)	Output During Suspension (V)
0.5	3.5

Boston Scientific Confidential. Unauthorized use is prohibited.

LIT APPROVAL - INGENIO 1-2 MRI REF GUIDE US

**Table 2-2. Pacing output during Automatic Capture Suspension** (continued)

Last Measured Threshold (V)	Output During Suspension (V)
1.0	3.5
2.0	4.0
3.0	5.0

Although RVAC is designed to work with a wide range of leads, in some patients the lead signals may hinder successful determination of the ventricular threshold. In these instances, RVAC will continually operate in the Suspension mode with a minimum ventricular output of 3.5 V and a maximum of 5.0 V. In situations where Suspension mode persists for an extended period of time, it is recommended to turn RVAC off by programming a fixed ventricular output.

### Commanded Right Ventricular Automatic Capture Measurement

An automatic capture measurement can be commanded via the Threshold Tests screen by selecting Auto Amplitude as the Test Type. If testing completes successfully and RVAC is programmed on, it will enter its beat-to-beat capture verification mode with the output set to 0.5 V above threshold (if the test is performed in the currently programmed pacing lead configuration). This can be confirmed by observing the output voltage on the Brady Settings screen, which will show the actual operating voltage of the RVAC algorithm (the ventricular threshold + 0.5 V).

Backup pacing between 3.5 V to 5.0 V is delivered approximately 70 ms after the primary pace for every loss of capture beat during commanded testing.

If testing is unsuccessful, the Threshold Tests screen will display the reason the test was not successful and RVAC will enter Suspension (Table 2-3 on page 2-21).

**NOTE:** For the initial Ventricular Threshold Test after the pulse generator is implanted, the Test Type field is seeded to Auto. Choose the desired test type from the Test Type field options, and adjust any other programmable values as appropriate.

### Test Results and Lead Alerts

A stored EGM for the most recent successful ambulatory test will be stored in the Arrhythmia Logbook ("Arrhythmia Logbook" on page 4-2). Refer to the Daily Measurements screen for the resulting threshold value. If desired, the stored EGM can be reviewed to determine where loss of capture occurred.

Up to 12 months of Ambulatory Threshold Test results, as well as test failure codes and lead alerts, can be found within the Daily Measurement and Trends screens. To provide further information on the reason for test failure, a failure code is provided for each day in which testing fails. Additionally, failure codes are provided on the Threshold Test screen if a commanded automatic capture test does not complete successfully. Threshold Test Failure Codes are listed below (Table 2-3 on page 2-21).

The following scenarios will trigger the Check RV Lead alert:

- Threshold > Programmed Amplitude will be displayed if RVAC is in Daily Trend mode and the ambulatory test results of the last 4 consecutive days exceed the manually programmed fixed output.
- Automatic Capture Suspension will be displayed if no successful tests are performed for 4 consecutive days in Auto or Daily Trend mode.

Boston Scientific Confidential. Unauthorized use is prohibited.

LIT APPROVAL - INGENIO 1-2 MRI REF GUIDE US



**Table 2-3. Threshold Test Failure Codes**

Code	Reason
N/R: device telem.	Telemetry started during an ambulatory test
N/R: comm. lost	Telemetry was lost during a commanded test
> 3.0 V	Threshold was measured between 3.5 V and 3.1 V for commanded or ambulatory tests
N/R: no capture	Capture was not obtained at the starting amplitude for commanded or ambulatory tests
N/R: mode switch	ATR either started or stopped (testing will not fail if ATR is already active and stays active during testing)
No data collected	Minimum pacing amplitude was reached without losing capture for an ambulatory test, or neither Auto nor Daily Trend is turned on to obtain an ambulatory test result
N/R: battery low	Test was skipped due to Battery Capacity Depleted
N/R: noise	Too many consecutive sense channel noise or Evoked Response noise cycles occurred
N/R: incompat. mode	Test failed due to being in an incompatible Brady mode (Magnet Mode)
N/R: rate too high	Rate was too high at the start of the test, or during testing
N/R: user cancelled	Commanded test was stopped by the user
N/R: intrinsic beats	Too many cardiac cycles occurred during the test
N/R: test delayed	Test was delayed due to telemetry being active, VT episode already in progress, Electrocautery mode, MRI Protection Mode, or RVAC was turned on while the device remained in Storage mode
N/R: respiration	Respiratory artifact was too high
N/R: low ER	The Evoked Response signal could not be assessed adequately
Auto N/R	Minimum pacing amplitude was reached without losing capture for a commanded test or telemetry is manually cancelled during a commanded test
Invalid Failure Code	Unexpected Failure

## Sensitivity

This feature is available in ACCOLADE, PROPONENT, ESSENTIO, ALTRUA 2, FORMIO, VITALIO, INGENIO, and ADVANTIO devices.

The Sensitivity feature can be programmed to either AGC or Fixed Sensing. The Sensitivity feature allows the pulse generator to detect intrinsic cardiac signals that exceed the programmed Fixed Sensitivity value or the dynamically increasing sensitivity of AGC. Adjusting the Sensitivity value shifts the atrial and/or ventricular sensing range to higher or lower sensitivity. Detection and timing decisions are based on the sensed cardiac signals. Although the atrial and ventricular Sensitivity values are independently programmable, the type of sensing method used (AGC or Fixed) must be the same for all chambers.

- High Sensitivity (low programmed value)—when Sensitivity is programmed to a very sensitive setting, the pulse generator may detect signals unrelated to cardiac depolarization (oversensing, such as sensing of myopotentials)
- Low Sensitivity (high programmed value)—when Sensitivity is programmed to a less sensitive setting, the pulse generator may not detect the cardiac depolarization signal (undersensing)

Boston Scientific Confidential. Unauthorized use is prohibited.

**LIT APPROVAL - INGENIO 1-2 MRI REF GUIDE US**

**CAUTION:** When a single pass VDD lead is used with a dual-chamber device, the atrial electrodes may not be in contact with the atrial wall. In this case, the measured depolarization signal has a relatively low Amplitude and could require a more sensitive setting.

**NOTE:** Use of VDD leads is inconsistent with the Conditions of Use required for MR Conditional status. Refer to the MRI Technical Guide for warnings, precautions, and other information about MRI scanning.

Should it become necessary to adjust the Sensitivity parameter in a chamber, always choose the setting that provides appropriate sensing of intrinsic activity and best resolves oversensing/undersensing.

If proper sensing cannot be restored with an adjustment or if any undersensing or oversensing is observed after making a change, consider any of the following (taking into account individual patient characteristics):

- Reprogram the Sensing Method from Fixed to AGC or from AGC to Fixed

**NOTE:** The Sensing Method selected applies to all chambers. When changing the Sensing Method, verify appropriate sensing in all chambers.

- Reprogram the AGC or Fixed sensitivity value
- Evaluate the sensing lead configuration (Unipolar versus Bipolar or Bipolar versus Unipolar)
- Reprogram the Refractory or cross-chamber blanking period appropriately to address the observed undersensing or oversensing
- Reposition the lead
- Implant a new sensing lead

After any change to Sensitivity, evaluate the pulse generator for appropriate sensing and pacing.

**CAUTION:** Following any Sensitivity parameter adjustment or any modification of the sensing lead, always verify appropriate sensing. Programming Sensitivity to the highest value (lowest sensitivity) may result in undersensing of cardiac activity. Likewise, programming to the lowest value (highest sensitivity) may result in oversensing of non-cardiac signals.

### Unipolar Sensing

When the unipolar sensing configuration is programmed, the cardiac signals are detected between the lead tip and the pulse generator case. In the unipolar sensing configuration, the pacemaker can generally discern smaller intrinsic cardiac signals than in the bipolar configuration. However, the unipolar configuration is also more sensitive to myopotentials. In bipolar configurations, due to the relatively short distance between the tip and ring electrodes, sensitivity is highest for signals originating in the proximity of the lead tip and ring. As a result, the pulse generator is less likely to sense myopotentials and other signals unrelated to cardiac depolarization.

**NOTE:** Consider using Fixed Sensing instead of AGC for patients who are pacemaker-dependent or have leads programmed to unipolar.

**NOTE:** Blanking Period behavior will vary depending on which Lead Configuration is selected. Refer to cross-chamber blanking for more details ("Cross-Chamber Blanking" on page 2-66).

**CAUTION:** The amplitude and prevalence of myopotential noise is increased in unipolar lead configurations, as compared to bipolar lead configurations. For patients with a unipolar lead configuration and myopotential oversensing during activity involving the pectoral muscles, the programming of Fixed Sensitivity is recommended.

Boston Scientific Confidential. Unauthorized use is prohibited.

LIT APPROVAL - INGENIO 1-2 MRI REF GUIDE US

### Automatic Gain Control

The pulse generator has the option to use digital Automatic Gain Control (AGC) to dynamically adjust the sensitivity in both the atrium and the ventricle. The pulse generator has independent AGC circuits for each chamber. Selection of the AGC Sensing Method applies that method to all chambers.

Cardiac signals can vary widely in size and rate; therefore the pulse generator needs the ability to:

- Sense an intrinsic beat, regardless of rate or size
- Adjust to sense varying amplitude signals, but not overreact to aberrant beats
- Sense any intrinsic activity after a paced beat
- Ignore T-waves
- Ignore noise

The programmable AGC value is the minimum sensitivity value (floor) that could be reached between one beat and the next beat. This programmable value is not a fixed value present throughout the cardiac cycle; rather, the sensitivity level begins at a higher value (based on the peak of a sensed event or a fixed value for a paced event) and decrements towards the programmed floor (Figure 2-8 on page 2-25).

With Fixed Sensing, signal amplitudes below the Fixed Sensitivity setting will not be sensed, whether during pacing or sensing. In contrast, AGC will typically reach the programmable floor during pacing (or with low amplitude signals). But when moderate or high amplitude signals are sensed, AGC will typically be less sensitive and not reach the programmable floor.

In single-chamber pulse generators, the AGC (and the associated Refractory Period) is automatically adjusted so that the appropriate chamber-specific AGC profile is utilized based on the mode selected [e.g., ventricular AGC is utilized in VVI(R); atrial AGC is utilized in AAI(R)]. This ensures that AGC will function the same for the atrium or ventricle in both dual- and single-chamber pulse generators ("Refractory" on page 2-62).

The AGC circuit in each respective chamber processes an electrogram signal via a two step process to optimize sensing of potentially rapidly changing cardiac signals. The process is illustrated in the figure below (Figure 2-8 on page 2-25):

- First step
  1. AGC uses a rolling average of previous signal peaks to calculate a search area where the next peak will likely occur.
    - If the previous beat is sensed, it is incorporated into the rolling peak average.
    - If the previous beat is paced, the peak average is calculated using the rolling average and a paced peak value. The paced peak value depends on the settings:
      - For nominal or more sensitive settings, it is a fixed value (initial value 4.8 mV in the RV; initial value 2.4 mV in the RA).
      - For less sensitive settings, it is a higher value calculated using the programmed AGC floor value (for example, if RV sensitivity is programmed to the least sensitive setting or the highest value of 1.5 mV, the paced peak value = 12 mV).

The peak average is then used to bound an area with MAX (maximum) and MIN (minimum) limits.

- Second step
  2. AGC senses the peak of the intrinsic beat (or uses the calculated peak for a paced beat as described above).
  3. It holds the sensitivity level at the peak (or MAX) through the absolute refractory period + 15 ms.
  4. It drops to 75% of the sensed peak or calculated peak average for paced events (ventricular paced events only).
  5. AGC becomes more sensitive by 7/8 of the previous step.
  6. Sensed beat steps are 35 ms for the RV and 25 ms for the atrium. Paced beat steps are adjusted based on the pacing interval to ensure an approximately 50 ms sensing window at the MIN level.
  7. It reaches the MIN (or programmed AGC floor).
    - The programmed AGC floor will not be reached if the MIN value is higher.
  8. The AGC remains at the MIN (or programmed AGC floor) until a new beat is sensed, or the pacing interval times out and a pace is delivered.

**NOTE:** If a new beat is sensed as the sensitivity level steps down, AGC starts over at Step 1.

**NOTE:** If the amplitude of a signal is below the sensitivity threshold in effect at the time the signal occurs, it will not be sensed.

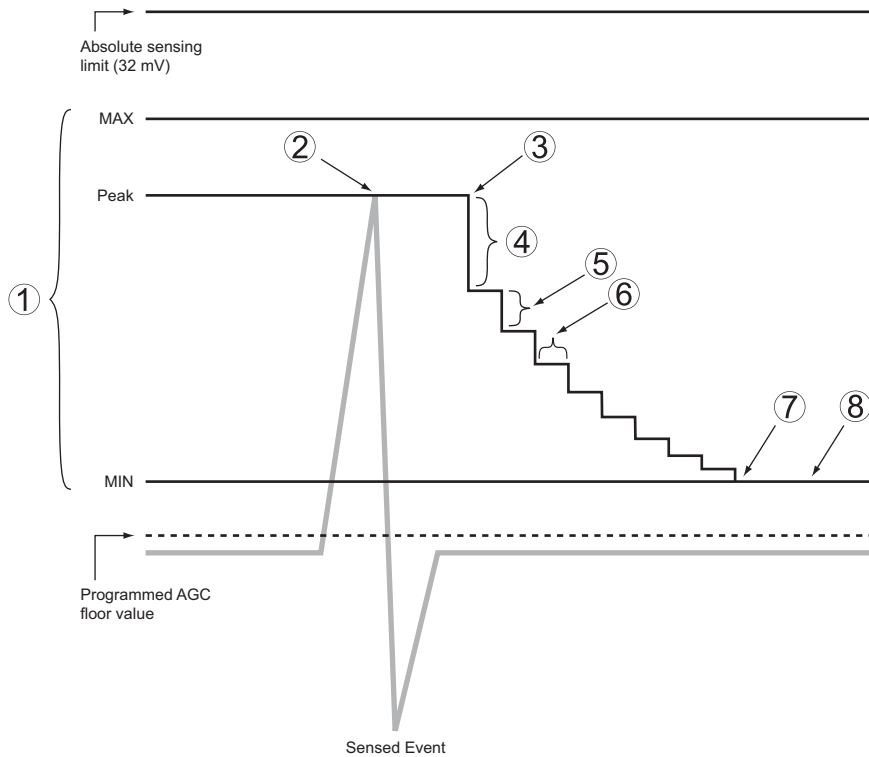

Figure 2-8. AGC sensing

A nonprogrammable Dynamic Noise Algorithm is active in rate channels where AGC sensing is used. The Dynamic Noise Algorithm is intended to help filter out persistent noise. The Dynamic Noise Algorithm is a separate noise channel for each chamber that continuously measures the baseline signal that is present and is designed to adjust the sensitivity floor to minimize the effects of noise.

The algorithm uses the characteristics of a signal (frequency and energy) to classify it as noise. When persistent noise is present, the algorithm is designed to minimize its impact, which may help to prevent oversensing myopotentials and the associated inhibition of pacing. Noise that affects the sensing floor may be visible on the intracardiac EGMs, but would not be marked as sensed beats. However, if the noise is significant, the floor may rise to a level above the intrinsic electrogram and the programmed Noise Response behavior (asynchronous pacing or Inhibit Pacing) will occur ("Noise Response" on page 2-69).

**NOTE:** *The Dynamic Noise Algorithm does not ensure that AGC will always accurately distinguish intrinsic activity from noise.*

### Fixed Sensing

With Fixed Sensing, the Sensitivity value will not dynamically adjust as in AGC, and the Dynamic Noise Algorithm is not utilized. Presence of persistent noise will result in the programmed Noise Response behavior: asynchronous pacing or Inhibit Pacing ("Noise Response" on page 2-69). For manual programming, Sensitivity must be programmed to a value that prevents sensing of extraneous signals, but ensures accurate sensing of intrinsic cardiac signals. Signals with an amplitude below the Fixed Sensitivity setting will not be sensed.

**WARNING:** If programmed to a fixed atrial Sensitivity value of 0.15 mV, or a fixed sensitivity value of 2.0 mV or less in a unipolar lead configuration in any chamber, the pulse generator may be more susceptible to electromagnetic interference. This increased susceptibility should be taken into consideration when determining the follow-up schedule for patients requiring such a setting.

## TEMPORARY BRADY PACING

This feature is available in ACCOLADE, PROPONENT, ESSENTIO, ALTRUA 2, FORMIO, VITALIO, INGENIO, and ADVANTIO devices.

The pulse generator can be programmed with temporary pacing parameter values that differ from the programmed Normal Settings. This allows you to examine alternate pacing therapies while maintaining the previously programmed Normal Settings in the pulse generator memory. During the Temporary function, all other bradycardia features not listed on the screen are disabled.

To use this function, follow these steps:

1. From the Tests tab, select the Temp Brady tab to display the temporary parameters.
2. Select the desired values; these values are independent from other pacing functions.

**NOTE:** *Temporary Brady interactive limits must be corrected before Temporary pacing can occur.*

**NOTE:** *If Off is selected as the Temporary Brady Mode, the pulse generator will not sense or pace while Temporary pacing mode is in effect.*

3. Establish telemetry communication, then select the Start button. Pacing begins at the temporary values. A dialog box indicates that temporary parameters are being used, and a Stop button is provided.

**NOTE:** *Temporary pacing cannot be started while a tachyarrhythmia episode is in progress.*

**NOTE:** *Emergency therapy is the only function that can be initiated until the Temporary function is stopped.*

4. To stop the Temporary pacing mode, select the Stop button. The Temporary pacing mode also stops when you command emergency therapy from the PRM, when you press the DIVERT THERAPY key, or if telemetry is lost.

Once Temporary pacing mode is stopped, pacing reverts to the previously programmed Normal settings.

## RATE ADAPTIVE PACING AND SENSOR TRENDING

### Rate Adaptive Pacing

In rate adaptive pacing modes (i.e., any mode ending with R), sensors are used to detect changes in the patient's activity level and/or physiologic demand and increase the pacing rate accordingly. Rate adaptive pacing is intended for patients who exhibit chronotropic incompetence and who would benefit from increased pacing rates that are concurrent with increased activity level and/or physiologic need.

The device can be programmed to use the Accelerometer, Minute Ventilation, or a blend of both. The clinical benefit of rate adaptive pacing using either of these sensors has been shown in previous clinical studies.

Boston Scientific Confidential. Unauthorized use is prohibited.

LIT APPROVAL - INGENIO 1-2 MRI REF GUIDE US

**CAUTION:** Rate Adaptive Pacing should be used with care in patients who are unable to tolerate increased pacing rates.

When rate adaptive parameters are programmed, the pacing rate increases in response to increased activity level and/or physiologic need, then decreases as appropriate.

**NOTE:** Activity involving minimal upper body motion, such as bicycling, may result in only a moderate pacing response from the accelerometer.

## Accelerometer

This feature is available in ACCOLADE, PROPONENT, ESSENTIO, ALTRUA 2, FORMIO, VITALIO, INGENIO, and ADVANTIO devices.

Motion-Based Pacing uses an accelerometer to detect motion that is associated with a patient's physical activity and generates an electronic signal that is proportional to the amount of body motion. Based on accelerometer input, the pulse generator estimates the patient's energy expenditure as a result of exercise, then translates it into a rate increase.

The pulse generator senses body motion by means of an integrated circuit accelerometer. The accelerometer sensor responds to activity in the frequency range of typical physiologic activity (1–10 Hz). The accelerometer evaluates both the frequency and the amplitude of the sensor signal.

- Frequency reflects how often an activity occurs (e.g., the number of steps taken per minute during a brisk walk)
- Amplitude reflects the force of motion (e.g., the more deliberate steps taken while walking)

Once detected, an algorithm translates the measured acceleration into a rate increase above the LRL.

Because the accelerometer is not in contact with the pulse generator case, it does not respond to simple static pressure on the device case.

There are three Accelerometer settings: On, Passive, and ATR Only. If the pulse generator is permanently programmed to a non-rate adaptive mode, it is possible to program the ATR Fallback mode to an adaptive-rate mode using the accelerometer sensor. In this case, the Accelerometer field will display ATR Only. If Passive is selected, the Accelerometer will not provide rate response but will continue to collect data for Sensor Trending.

The following programmable parameters control the pulse generator's response to the sensor values generated by the Accelerometer:

- Response Factor
- Activity Threshold
- Reaction Time
- Recovery Time

### Response Factor (Accelerometer)

Response Factor (accelerometer) determines the pacing rate increase that will occur above the LRL at various levels of patient activity (Figure 2-9 on page 2-28).

- High Response Factor—results in less activity required for the pacing rate to reach the MSR

Boston Scientific Confidential. Unauthorized use is prohibited.

**LIT APPROVAL - INGENIO 1-2 MRI REF GUIDE US**

- Low Response Factor—results in more activity required for the pacing rate to reach the MSR

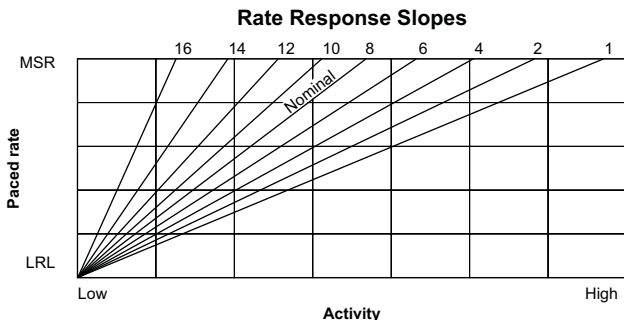
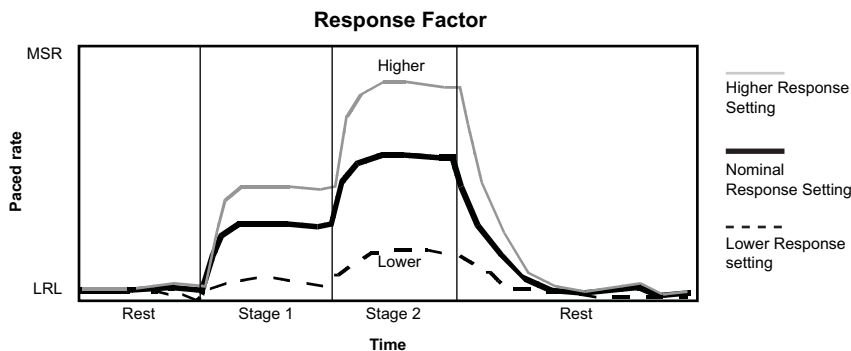

Figure 2-9. Response Factor and paced rate

The pacing rate achieved can be limited either by the detected activity level or the programmed MSR. If the detected activity level results in a steady-state rate below the MSR, the pacing rate can still increase when the detected activity levels increase (Figure 2-10 on page 2-28). The steady-state response is independent of the programmed reaction and recovery times.



This figure shows the effect of higher and lower settings during a theoretical two-stage exercise test.

Figure 2-10. Response Factor in exercise test

Programming the LRL up or down moves the entire response up or down without changing its shape.

**Activity Threshold**

Activity Threshold prevents rate increases due to low-intensity, extraneous motion (e.g., motion caused by respiration, heart beat, or in some cases tremor associated with Parkinson’s disease).

Activity Threshold represents the activity level that must be exceeded before the sensor-driven pacing rate will increase. The pulse generator will not increase the paced rate above the LRL until the activity signal increases above the Activity Threshold. An Activity Threshold setting should allow a rate increase with minor activity, such as walking, but be high enough so the pacing rate will not increase inappropriately when the patient is inactive (Figure 2-11 on page 2-29 and Figure 2-12 on page 2-29).

- Lower setting—less motion is required to increase the pacing rate
- Higher setting—more motion is required to increase the pacing rate

Boston Scientific Confidential. Unauthorized use is prohibited.

LIT APPROVAL - INGENIO 1-2 MRI REF GUIDE US



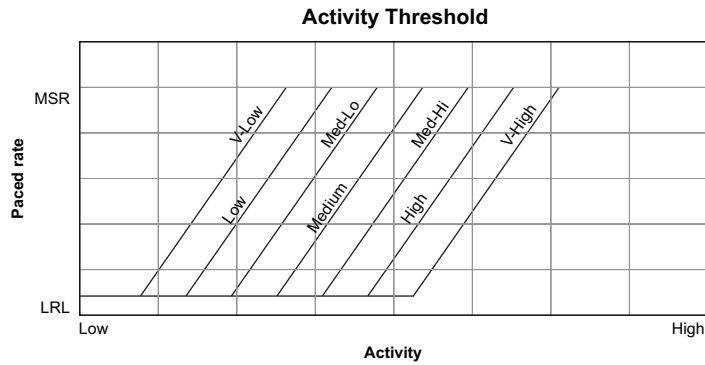
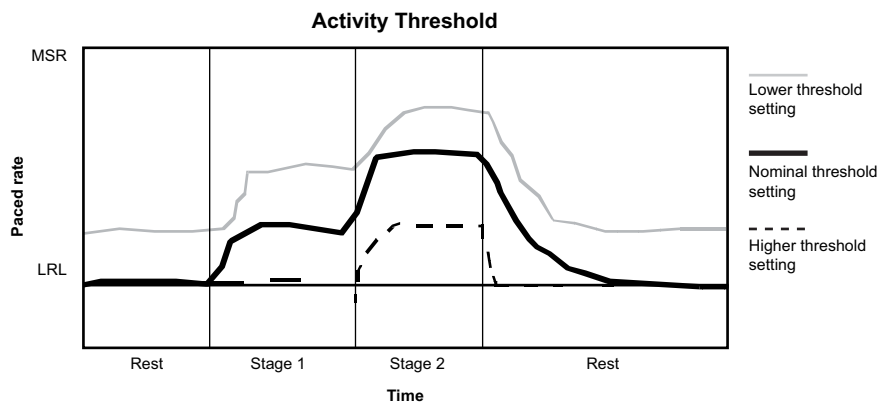

Figure 2-11. Activity Threshold and rate response



This figure demonstrates the effect of increased or decreased Activity Threshold settings in response to a theoretical two-stage exercise test.

Figure 2-12. Activity Threshold in exercise test

### Reaction Time

Reaction Time determines how quickly the pacing rate will rise to a new level once an increase in activity level is detected.

Reaction Time affects only the time required for a rate increase to occur. The value selected determines the time required for the paced rate to move from the LRL to the MSR for a maximum level of activity (Figure 2-13 on page 2-30 and Figure 2-14 on page 2-30).

- Short Reaction Time: results in a rapid increase in the pacing rate
- Long Reaction Time: results in a slower increase in the pacing rate

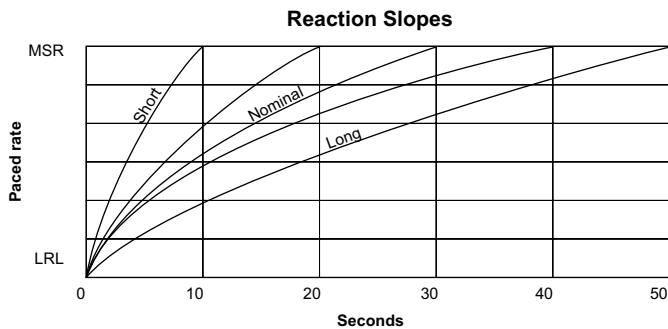

Figure 2-13. Reaction Time and paced rate

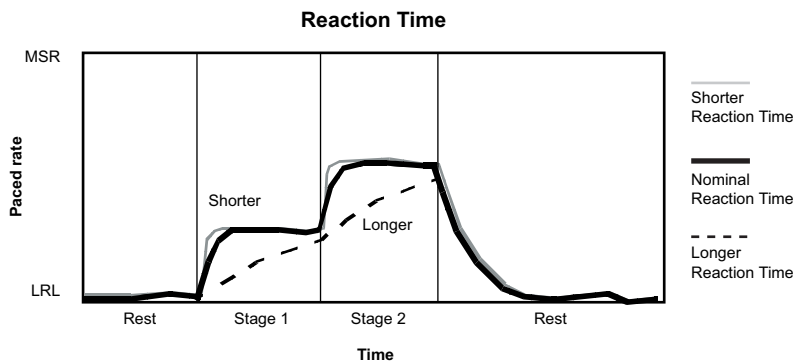
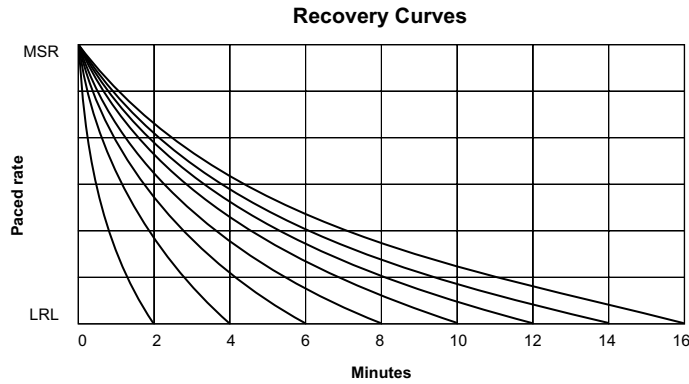

Figure 2-14. Reaction Time in exercise test

### Recovery Time

Recovery Time determines the time required for the paced rate to decrease from the MSR to the LRL in the absence of activity. When patient activity concludes, Recovery Time is used to prevent an abrupt decrease in pacing rate (Figure 2-15 on page 2-31 and Figure 2-16 on page 2-31).

- Short Recovery Time—results in a faster decrease in pacing rate after patient activity lowers or stops
- Long Recovery Time—results in a slower decrease in pacing rate after patient activity lowers or stops



There are 15 settings available; only the even-numbered settings are shown.

Figure 2-15. Recovery Time and paced rate

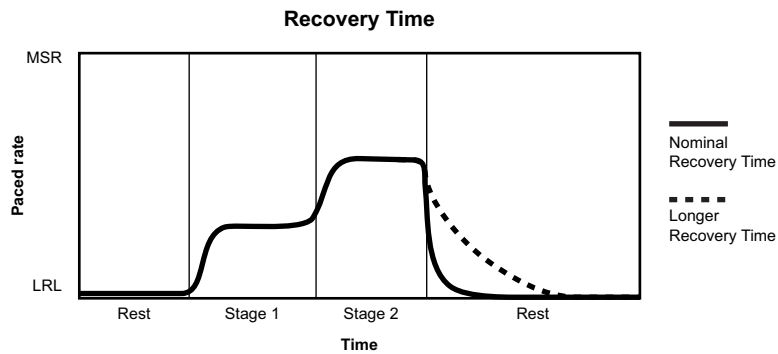

The figure shows the effect of higher and lower settings during a theoretical two-stage exercise test.

Figure 2-16. Recovery Time in exercise test

## Minute Ventilation (MV)

This feature is available in ACCOLADE, PROPONENT, ESSENTIO, ALTRUA 2, FORMIO, VITALIO, INGENIO, and ADVANTIO devices.

The pulse generator uses transthoracic impedance to measure minute ventilation (MV), which is the product of respiration rate and tidal volume. Based on the MV measurement, the pulse generator calculates the sensor-indicated rate.

**CAUTION:** Do not program the MV sensor to On until after the pulse generator has been implanted and system integrity has been tested and verified.

Approximately every 50 ms (20 Hz), the device will deliver a current excitation waveform between the RA Ring electrode and Can (primary vector) or the RV Ring electrode and Can (secondary vector). Since either lead may be used to measure MV, at least one of the implanted leads must have normal bipolar lead impedances.

**NOTE:** Only one vector is available in a single chamber device.

**NOTE:** If an RA lead is not used, only the secondary vector is available.

Boston Scientific Confidential. Unauthorized use is prohibited.

LIT APPROVAL - INGENIO 1-2 MRI REF GUIDE US

**NOTE:** Leads may be programmed Unipolar or Bipolar, but either Lead Configuration or Patient Information must indicate that a bipolar lead is present.

Inductive (wanded) telemetry may temporarily interfere with the pulse generator's MV sensor function. MV driven rates may hold at the current rate for approximately one minute immediately following any interrogation or programming command. This period will be indicated by a Sensor Status of Rate Hold: Telemetry (Table 2-4 on page 2-35). If a significant amount of data (for example, Arrhythmia Logbook episodes) is being retrieved from the device, the MV driven rate may then decrease to the LRL and further rate changes may not occur for several additional minutes. This time period will be indicated by a Sensor Status of Suspended: Telemetry (Table 2-4 on page 2-35).

If MV driven rate changes are desired prior to the rate hold or suspension periods, allow the MV driven rate to reach the desired rate prior to using inductive telemetry, or use RF telemetry to communicate with the device.

**CAUTION:** Any medical equipment, treatment, therapy, or diagnostic test that introduces electrical current into the patient has the potential to interfere with pulse generator function.

- External patient monitors (e.g., respiratory monitors, surface ECG monitors, hemodynamic monitors) may interfere with the pulse generator's impedance-based diagnostics (e.g., Respiratory Rate trend). This interference may also result in accelerated pacing, possibly up to the maximum sensor-driven rate, when MV is programmed to On. To resolve suspected interactions with the MV sensor, deactivate the sensor either by programming it to Off (no MV rate driving or MV sensor-based trending will occur), or Passive (no MV rate driving will occur). Alternatively, program the Brady Mode to a non-rate responsive mode (no MV rate driving will occur). If a PRM is not available and the pulse generator is pacing at the sensor-driven rate, apply a magnet to the pulse generator to initiate temporary asynchronous, non-rate responsive pacing.

During MV function, the active vector may be the primary vector (RA Ring electrode to Can) or secondary vector (RV Ring electrode to Can). Lead impedances for the active vector are evaluated each hour to assess lead integrity. If the active vector values are out of range, impedances for the alternate vector are evaluated to determine if that vector can be utilized for MV. If both the primary and secondary vectors are out of range, the sensor is suspended for the next one hour. Lead integrity will continue to be tested every hour to evaluate if the MV signal will use the primary vector, the secondary vector, or remain suspended. Acceptable lead impedance values are 200–2000  $\Omega$  for the tip to can vector and 100–1500  $\Omega$  for the ring to can vector.

If a vector switch occurs, an automatic 6-hour calibration will occur (no MV-driven rate response occurs during the 6-hour calibration period).

**NOTE:** The waveform in a single chamber device will originate from and be measured in the chamber where the lead is located.

The application of current between the ring electrode and the can will create an electrical field across the thorax, modulated by respiration. During inspiration the transthoracic impedance is high, and during expiration it is low. The device will measure the resulting voltage modulations between the lead tip electrode and the can.

**CAUTION:** If MV Sensor signal artifacts are observed on EGMs, and the leads are otherwise shown to be performing appropriately, consider programming the sensor to Off to prevent oversensing.

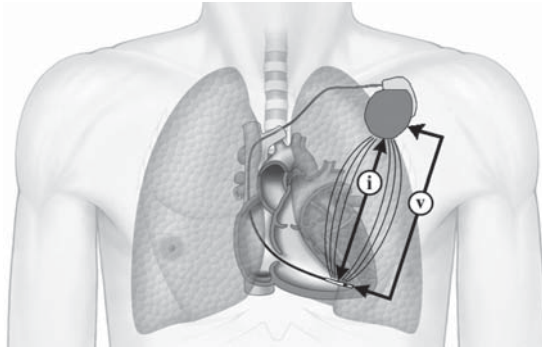

i = current, V = volts

**Figure 2-17. Measurement of the MV signal from the RV lead**

Due to advanced filtering, the algorithm supports breathing rates up to 72 breaths per minute. The filtered waveform is then processed to obtain the total volume measurement. The average excitation current that is delivered to the tissue is 320  $\mu\text{A}$ . If the noise becomes excessive, the MV sensor will be suspended until the noise level decreases. The excitation waveform is a balanced low amplitude signal that will not distort surface ECG recordings. On some ECG monitoring equipment, the waveforms may be detected and displayed. These waveforms are present only when the MV sensor is used.

The pulse generator keeps a long-term moving average (baseline) of these measurements (updated every 4 minutes) as well as a short-term (approximately 30-second) moving average, which is updated every 7.5 seconds. The magnitude of the difference between the short-term average and long-term baseline determines the magnitude of the rate increase over the LRL, or decrease down to the LRL. The increase or decrease in the sensor-indicated rate occurs at a maximum of 2 ppm per cycle (Figure 2-18 on page 2-33).

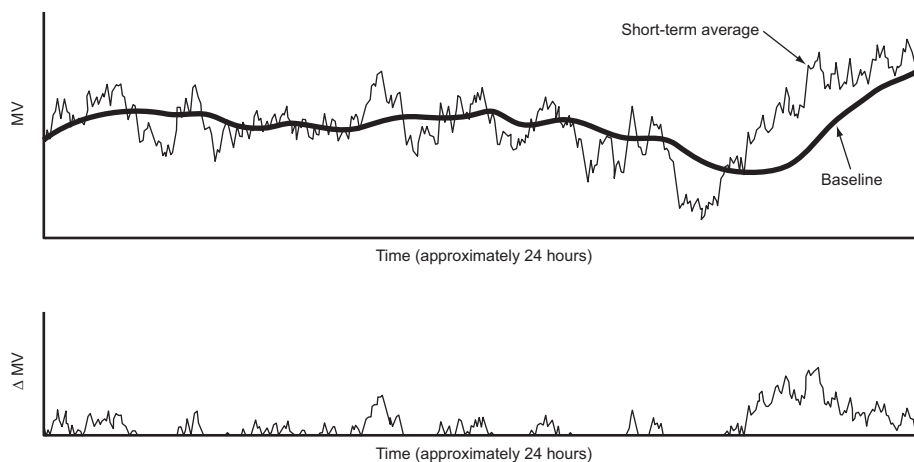

Top: The baseline (long-term average) follows the drift of the short-term average. Bottom: The difference between the short- and long-term average is used for increasing the sensor-driven rate upon exertion.

**Figure 2-18. Difference between MV short-term average and MV baseline**

**NOTE:** Whenever a magnet is applied and the Magnet Response has been programmed to Pace Async, the pacemaker will pace asynchronously at the magnet rate and will not respond to MV data.

Boston Scientific Confidential. Unauthorized use is prohibited.

LIT APPROVAL - INGENIO 1-2 MRI REF GUIDE US

**CAUTION:** Program the MV Sensor to Off during mechanical ventilation. Otherwise, the following may occur:

- Inappropriate MV sensor-driven rate
- Misleading respiration-based trending

For optimal rate response, a variety of Minute Ventilation parameters can be programmed via the RightRate Pacing area on the Rate Adaptive Pacing Settings screen.

To activate the MV sensor, the system needs a measure of the baseline or resting MV. Methods for calibration include:

- **Automatic Calibration.** An automatic, 6-hour calibration will occur whenever MV is programmed to On or Passive. No MV-driven rate response or hourly lead integrity checks will occur during the 6-hour calibration time.
  - For ACCOLADE, PROPONENT, ESSENTIO, and ALTRUA 2 devices, if MV is programmed to On at implant, the first hourly lead check with acceptable lead impedance values will begin a 2-hour wait period followed by the 6-hour calibration. This 2-hour period will be indicated by a sensor status of Initializing and is intended to allow the implantation procedure to be completed.
  - For FORMIO, VITALIO, INGENIO, and ADVANTIO devices, if MV is programmed to On at implant, there is a 2-hour wait period after lead attachment, followed by the 6-hour calibration. This 2-hour period will be indicated by a sensor status of Suspended and is intended to allow the implantation procedure to be completed.

**NOTE:** If MV is programmed to On or Passive at the time of entry into MRI Protection Mode, upon exit from MRI Mode, an automatic 6-hour calibration will begin. If MV-driven rate response is desired sooner, a manual calibration can be performed.

- **Manual Calibration.** Whenever MV is programmed On, (including during the 2-hour period following lead attachment) the sensor can be calibrated manually. From the RightRate Pacing Details screen, select the Start Sensor Calibration button to initiate the manual calibration process. If the calibration is successful, MV-driven rate response takes effect within one minute. Manual calibration may take as little as 2 minutes or as much as 5 minutes to complete, depending on whether noise is encountered during data collection. The patient should be resting quietly and breathing normally for a few minutes prior to and during the manual calibration. If the manual calibration fails due to noise, it will be indicated by a Suspended: Noise Detected sensor status and the 6-hour automatic calibration will automatically begin.
  - For ACCOLADE, PROPONENT, ESSENTIO, and ALTRUA 2 devices, if the manual calibration fails due to no valid MV lead vector (indicated by a sensor status of Suspended: No Valid Lead) the pulse generator will continue to check for a valid vector every hour and will start the 6-hour calibration once a valid vector is detected.
  - For FORMIO, VITALIO, INGENIO, and ADVANTIO devices, if the manual calibration fails due to no valid MV lead vector (indicated by a sensor status of Suspended) the pulse generator will continue to check for a valid vector every hour and will start the 6-hour calibration once a valid vector is detected.

**NOTE:** The Manual Calibration method will not be available upon initial interrogation while information such as Arrhythmia Logbook episodes are retrieved from the device. This will be indicated by a dimmed Start Sensor Calibration icon and may occur for seconds to minutes depending on the amount of data being retrieved.

There is no clinical difference between the Automatic and the Manual calibration methods. A successful Manual calibration simply allows a baseline to be obtained and MV-driven rate response to begin immediately. Neither calibration method requires that telemetry communication be maintained for the duration of the calibration.

**CAUTION:** To obtain an accurate MV baseline, the MV sensor will be calibrated automatically or can be calibrated manually. A new, manual calibration should be performed if the pulse generator is removed from the pocket following implant, such as during a lead repositioning procedure, or in cases where the MV baseline may have been affected by factors such as lead maturation, air entrapment in the pocket, pulse generator motion due to inadequate suturing, external defibrillation or cardioversion, or other patient complications (e.g., pneumothorax).

The PRM will display one of the messages below to indicate the current MV Sensor Status on the RightRate Pacing Details screen (Figure 2-21 on page 2-37).

The messages are all updated in real-time for ACCOLADE, PROPONENT, ESSENTIO, and ALTRUA 2 devices. The messages of Suspended: Noise Detected, Suspended: Telemetry and Rate Hold: Telemetry are updated real-time while the remainder are updated upon interrogation for FORMIO, VITALIO, INGENIO, and ADVANTIO devices.

**Table 2-4. MV Sensor Status Messages**

Sensor Status	MV Sensor Driven Pacing	MV Sensor Data Collection <sup>a</sup>
Off	No	No
Initializing (ACCOLADE, PROPONENT, ESSENTIO, and ALTRUA 2 devices)	No	No
Manual Calibration in Progress	No	Yes
Auto Calibration in Progress	No	Yes
Calibrated	Yes <sup>b</sup>	Yes
Suspended	No	No
Suspended: No Valid Lead (ACCOLADE, PROPONENT, ESSENTIO, and ALTRUA 2 devices)	No	No
Suspended: Noise Detected	No	Yes
Suspended: Telemetry	No	Yes
Rate Hold: Telemetry	No <sup>c</sup>	Yes

- a. Individual Trends determine if data collected during Suspension is valid and incorporated into Trend results.
- b. If the MV Sensor is programmed to Passive, MV sensor driven pacing will not occur.
- c. Rate will hold at the current MV indicated value for up to one minute; further MV based rate changes will not occur with this sensor status.

There are four Minute Ventilation settings: On, Off, Passive, and ATR Only. If the pulse generator is permanently programmed to a non-rate adaptive mode, but a rate adaptive ATR Fallback mode is selected, the MV field will display ATR Only. If programmed to a non-rate adaptive mode, the 'On' setting is not available. If Passive is selected, the MV sensor will not provide rate response but will continue to collect data for use by other features (e.g., Sensor Trending).

**Response Factor (Minute Ventilation)**

An increase in MV over baseline due to an increase in metabolic demand will be detected by the pulse generator and converted by its algorithm into an increased pacing rate. The relationship between the detected increase in MV and the resulting increase in the sensor-indicated rate is established by the MV Response Factor.

The Response Factor parameter determines the pacing rate that will occur above the LRL at various elevated levels of MV. Larger response factor values will result in higher sensor rates for a given MV level (Figure 2-19 on page 2-36). The effects of higher and lower Response Factor settings on sensor-driven pacing rate during a theoretical two-stage exercise test are illustrated below (Figure 2-20 on page 2-36).

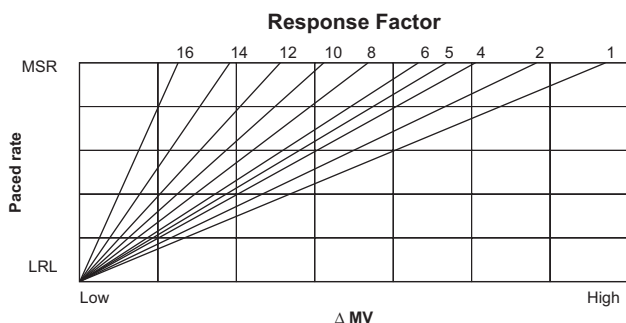

**Figure 2-19. Relationship between the programmed Response Factor setting and rate response**

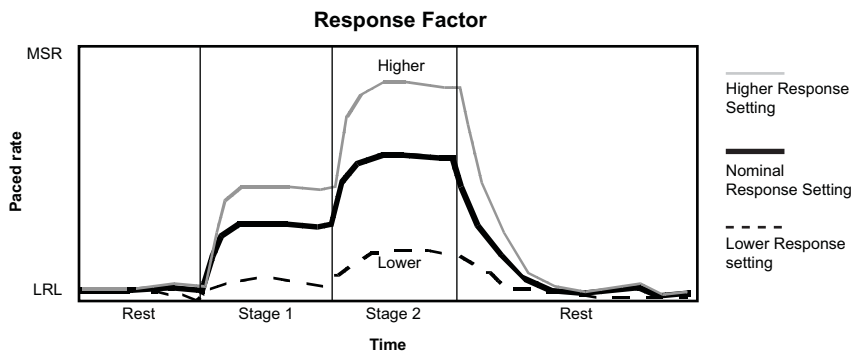

**Figure 2-20. Effects of Response Factor settings in a two-stage exercise test**

**Ventilatory Threshold and Ventilatory Threshold Response**

The Ventilatory Threshold and Ventilatory Threshold Response can be either manually programmed or automatically derived from patient information. The clinician can select Derive from Patient Attributes from the RightRate Pacing Details screen to obtain settings based on the patient’s age and gender (and Fitness Level, see below). As parameters are changed, the graph will likewise adjust to demonstrate the effect of the new programming on overall rate response (Figure 2-21 on page 2-37). If the Date of Birth or Gender is adjusted on the Patient Information screen, the new values will also be reflected on the RightRate Pacing Details screen.



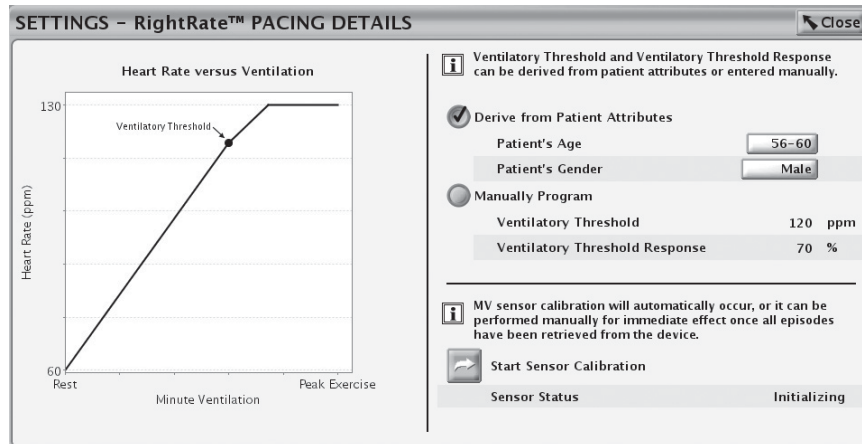

Figure 2-21. Ventilatory Threshold and Ventilatory Threshold Response

### Ventilatory Threshold

Ventilatory Threshold is a physiologic term describing the point during exercise when the breathing rate increases faster than the heart rate (sometimes referred to as Anaerobic or Lactate Threshold).

The Response Factor controls the MV rate response for sensor rates between the LRL and the Ventilatory Threshold. The Ventilatory Threshold Response controls the MV rate response when the sensor rate is above the Ventilatory Threshold.

### Ventilatory Threshold Response

The physiologic relationship between MV and rate is approximately bilinear as shown (Figure 2-22 on page 2-38). During exercise levels up to the Ventilatory Threshold, this relationship can be approximated by a linear relationship. At exertion levels above the Ventilatory Threshold, the relationship is still approximately linear, but at a reduced slope. The relationship between the two slopes varies from person to person and depends on several factors such as gender, age, and exercise frequency and intensity. The pulse generators allow programming of a slope above the Ventilatory Threshold that is less steep and thus designed to mimic the physiologic relationship between respiration rate and heart rate. The Ventilatory Threshold Response is programmed as a percentage of the Response Factor. Ventilatory Threshold Response is in effect at rates above the Ventilatory Threshold and will result in a less aggressive response to MV at higher rates (Figure 2-23 on page 2-38).

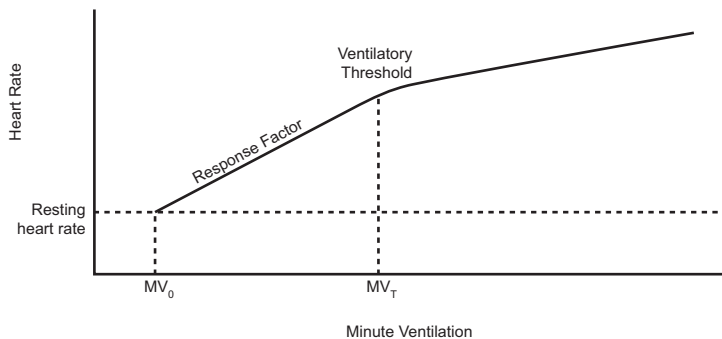

MV<sub>0</sub> = resting MV; MV<sub>T</sub> = MV at the Ventilatory Threshold

Figure 2-22. Typical physiologic relationship between MV and heart rate

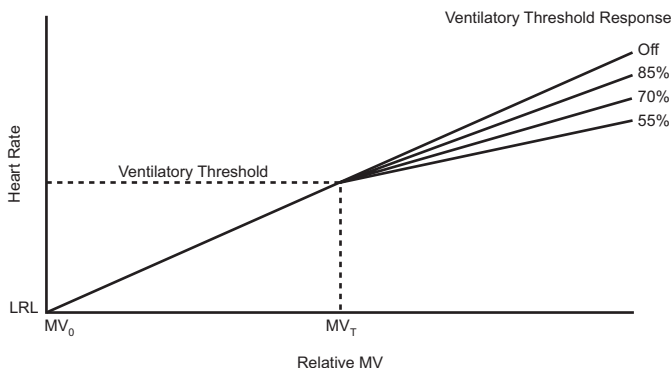

The Response Factor is linear from the resting state up to the Ventilatory Threshold (MV<sub>0</sub> = resting MV; MV<sub>T</sub> = MV at the Ventilatory Threshold).

Figure 2-23. Ventilatory Threshold Response

**Fitness Level**

The selected Fitness Level will automatically determine an appropriate Ventilatory Threshold Response factor and rate at which the MV baseline will be fixed.

Table 2-5. Recommended Fitness Level settings

Recommended Fitness Level setting	Patient activity level
Sedentary	Little to no physical activity
Active	Regular walking and low impact activities
Athletic	Moderate intensity, non-competitive jogging/biking
Endurance Sports	Strenuous, competitive activities such as marathons

The baseline (long-term average) is fixed for up to 4.5 hours. This allows active patients who exercise for a long duration (e.g., long-distance runners) to maintain an adequate sensor-driven rate throughout the exercise period. The baseline will be fixed when the sensor indicated rate is above 110 ppm for the Fitness Level setting of Endurance Sports or 90 ppm for the other three Fitness Level settings. After 4.5 hours, or when the sensor rate falls below 90 ppm or 110 ppm as defined above, baseline adaptation will be re-enabled.

### Dual-Sensor Blending

Whenever both the Accelerometer and the MV sensor are programmed On for rate adaptive pacing, the two sensor-indicated rates are blended to produce a rate-dependent, weighted average response. As a result, the blended response will always be equal to one of the rates or between the two rates. Whenever the Accelerometer response is less than the MV response, the sensor blending will be 100% MV-based. If the Accelerometer response is greater than the MV response, the blending will range from approximately 80% Accelerometer and 20% MV when the Accelerometer rate is at LRL, to approximately 40% Accelerometer and 60% MV when the Accelerometer rate is at MSR.

The following examples illustrate the blending algorithm operation.

#### Example 1

The Accelerometer detects motion with a simultaneous MV increase (Figure 2-24 on page 2-39). Upon exercise, the blended response will promptly (within 4 seconds) increase the rate based on the Accelerometer response. As the rate continues to increase, the blended response will be moving toward the MV response, but will always remain between the Accelerometer and MV responses. At higher rates, the changes in Accelerometer input will have a lesser effect on the blended response (only 40% at MSR), whereas changes in MV will have a more significant effect. At cessation of exercise, the Accelerometer rate will decrease as prescribed by the Recovery Time parameter and, in this example, will drop below the MV response. As a result, the algorithm will switch over to a 100% MV blend during the recovery phase for as long as the Accelerometer response remains below the MV response. When using dual-sensor blending, retain the nominal Accelerometer value of 2 minutes. This allows the physiologic MV signal to control rate adaptive pacing in the exercise recovery phase.

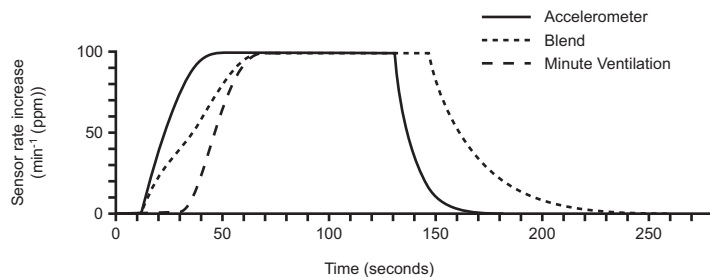

**Figure 2-24. Blended response with an Accelerometer Reaction Time of 30 seconds**

The aggressiveness of response at the onset of exercise can be controlled by programming a shorter Accelerometer Reaction Time (Figure 2-25 on page 2-39).

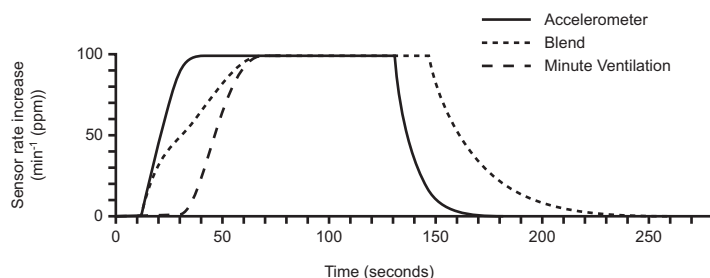

**Figure 2-25. Blended response with an Accelerometer Reaction Time of 20 seconds**

**Example 2**

The Accelerometer detects motion with little MV increase (Figure 2-26 on page 2-40). The response of the blended sensor will be limited to approximately 60% of the Accelerometer response. Once the Accelerometer response drops below the MV response during recovery, the blended response will be 100% MV-driven.

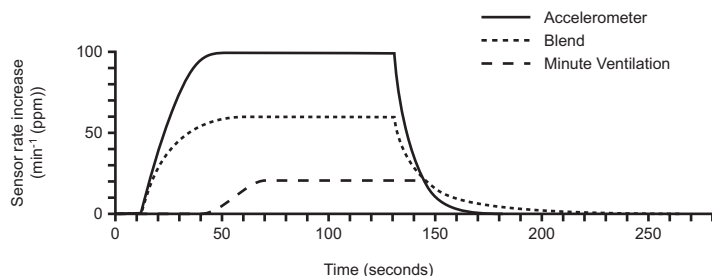

**Figure 2-26. Blended response: Accelerometer detects motion with little or no increase in MV**

**Example 3**

MV increases with little Accelerometer rate increase (Figure 2-27 on page 2-40). The blended response will initially increase with the Accelerometer response, but as the MV response increases over the Accelerometer response, the blended response will be 100% MV-driven. This provides adequate response during increases in metabolic demand under conditions of little or no upper body movement.

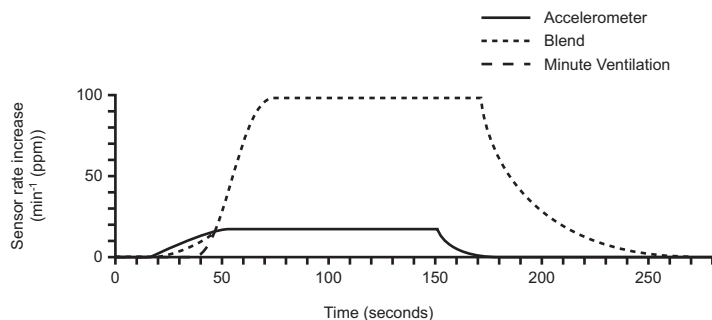

**Figure 2-27. Blended response: MV increase with little or no motion detected by the Accelerometer**

**Sensor Trending**

This feature is available in ACCOLADE, PROPONENT, ESSENTIO, ALTRUA 2, FORMIO, VITALIO, INGENIO, and ADVANTIO devices.

Sensor Trending provides a graphical display of the pulse generator's rate response to the patient's detected activity level and/or physiologic need and provides useful information during exercise testing. This allows the clinician to adapt the sensor-driven pacing rate to correspond to the patient's actual need.

The Sensor Trending graph and Sensor Trending Setup parameters are viewable via the Rate Adaptive Pacing screen.

The Sensor Trending graph (Figure 2-28 on page 2-41) identifies a fixed range of heart rates (80–100 ppm) for Light to Moderate Exertion. This range can be used as a guide for target heart rates corresponding to regular walking and other low impact activities and may help identify patients with chronotropic incompetence.<sup>1 2</sup> This range may vary due to factors such as patient age and the type of exercise.<sup>2</sup>

The up and down buttons (Figure 2-28 on page 2-41) for More MV Pacing and Less MV Pacing are an alternate method to manually selecting the RightRate Response Factor. Each press of the button changes the RightRate Response Factor by one. The up button increases the Response Factor, and the down button decreases the Response Factor. For further information about sensor optimization, refer to the section about working with trending data below.

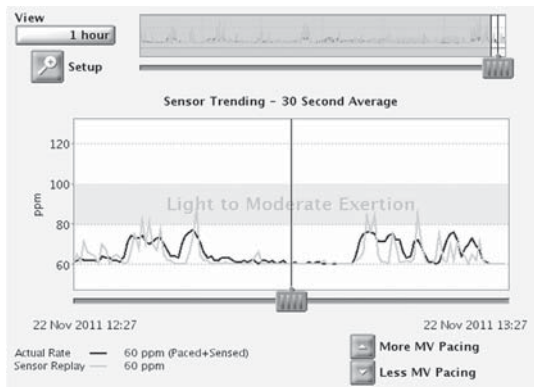

Figure 2-28. Sensor Trending graph with exertion range

Setup includes the following options:

- Recording Method—programmable:
    - 30-Second Average—records and plots the average rate every 30 seconds.
    - Beat to Beat—records and plots the rate of every beat.

**NOTE:** *Beat to Beat is recommended when using hall walks or shorter periods of activity to manually optimize sensor rates.*

  - Off—no trending data is gathered.
- Duration—non-programmable and based on the selected Recording Method:
    - When Recording Method is set to Off or 30-Second Average—Duration is approximately 25 hours.
    - When Recording Method is set to Beat to Beat—Duration is approximately 40 minutes at 75 bpm.

1. Scherr, J. et al., Associations between Borg's rating of perceived exertion and physiologic measures of exercise intensity. *Eur J. Appl Physiol*, Vol. 113 (1): 147-155, 2013.

2. Newman et al., Walking Performance and Cardiovascular Response: Associations with Age and Morbidity—The Health Aging and Body Composition Study. *J. of Gerontology*, Vol. 58A (8): 715-720, 2003.

Boston Scientific Confidential. Unauthorized use is prohibited.

- Data Storage—programmable:
  - Continuous—contains the most recent data available. Storage starts when setup is confirmed and continuously records the latest information, overwriting the oldest data until the information is retrieved. This option allows you to view data for the recording duration immediately prior to data retrieval.
  - Fixed—storage starts when setup is confirmed and continues until device memory storage is full. This allows you to view data from initial setup for a fixed amount of time.

The pulse generator collects and stores rate and sensor data which is then displayed on the PRM in a graphical format as the patient's Actual Rate and Sensor Replay during the recording time.

The Actual Rate (black line) indicates the patient's heart rate during activity (whether paced or sensed). The Sensor Replay (orange line) depicts the sensor-driven heart rate response with the current sensor parameter settings. As the slider along the horizontal axis of the graph is moved, actual and sensor-indicated heart rates are displayed for particular data points. Additionally, the atrial events represented by a particular data point (single beat or 30-second average) are classified and displayed next to the Actual Rate. Events are classified and displayed as one or more of the following: Paced, Sensed, Sensed in ATR. This event type will reflect ventricular events in VVI(R) modes.

Current sensor parameters can be adjusted to view the resulting change to sensor rate behavior without having to repeat an exercise test.

The pulse generator can collect and store data in rate adaptive and non-rate adaptive modes. In non-rate adaptive modes, the trending is collected via the Passive sensor setting. Passive allows for sensor data collection that can be used to optimize the sensors in the absence of the sensor-driven rate response. However, when the sensor setting is Passive, Sensor Replay data will not be displayed on the graph until a rate responsive mode is selected.

The pulse generator will record Sensor Trending data while wanded or RF telemetry is active.

When the heart rate is completely sensor-driven, small differences between the Actual Rate and Sensor Replay may still be observed because they are calculated independently by slightly different methods.

### Working with Trending Data

To use the Sensor Trending function, follow these steps:

1. Following an exercise session, navigate to the Sensor Trending graph and press Interrogate to update trending information. Trending data is retrieved on initial interrogation. If a session remains active while the patient performs a hall walk, press Interrogate again to update the trending information.
2. Select the View button to expand or compress the amount of data viewed at one time. The start and end dates and times at the bottom of the graph will change to reflect the time period represented on the graph. The 30 Second Average Recording Method has options for 1 to 25 hours, and the Beat to Beat Recording Method has options for 5 to 40 minutes.
3. To adjust which data is displayed on the graph or to view particular data points, move the sliders along the horizontal axes at the bottom of the display windows.
4. Adjust the sensor parameters to the right of the graph to see how adjustments in the rate adaptive pacing parameters will affect the sensor response (orange line). As these parameters and/or the

Boston Scientific Confidential. Unauthorized use is prohibited.

LIT APPROVAL - INGENIO 1-2 MRI REF GUIDE US

MSR and LRL are changed on the screen, the application will modify the graph to illustrate the resulting effects. If the patient's heart rate is appropriate for the activity performed, no sensor optimization is necessary.

5. When a patient's heart rate is within the desired range for the activity performed, select Program.

**NOTE:** Sensor Trending results may be printed via the Reports tab. Both the Present (currently programmed) and Replay (clinician adjusted) parameters are provided in addition to the current graph as represented on the programmer screen.

**NOTE:** Sensor adjustments should not be based on data which is collected during the MV calibration time period.

## ATRIAL TACHY RESPONSE

### ATR Mode Switch

This feature is available in ACCOLADE, PROPONENT, ESSENTIO, ALTRUA 2, FORMIO, VITALIO, INGENIO, and ADVANTIO devices.

ATR is designed to limit the amount of time that the ventricular paced rate is at the MTR or exhibits upper-rate behavior (2:1 block or Wenckebach) in response to a pathological atrial arrhythmia.

In the presence of detected atrial activity that exceeds the ATR Trigger Rate, the pulse generator switches the pacing mode from a tracking mode to a nontracking mode as follows:

- From DDD(R) to DDI(R) or VDI(R)
- From VDD(R) to VDI(R)

An example of ATR behavior is shown (Figure 2-29 on page 2-43).

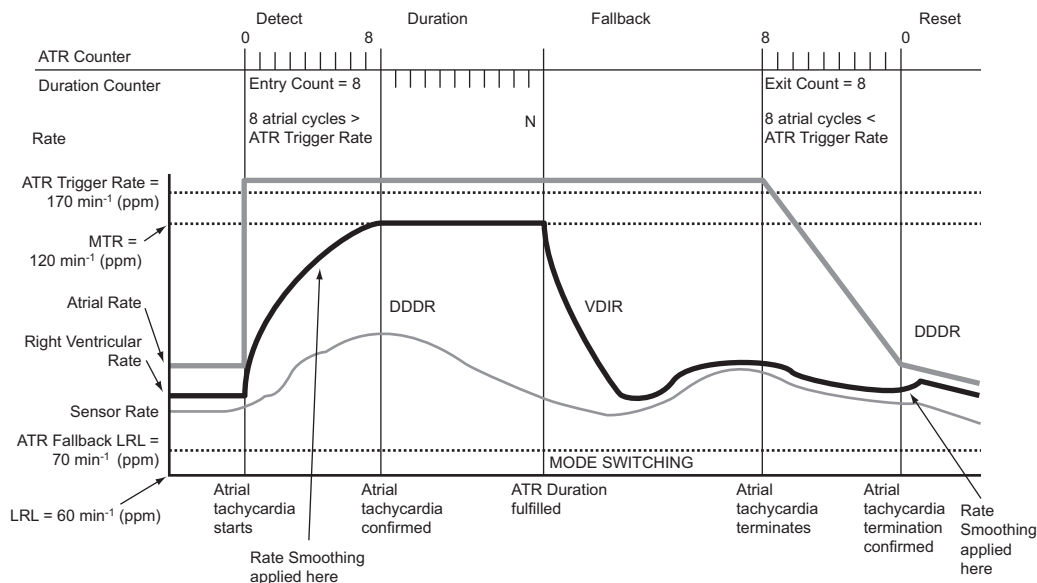

Figure 2-29. ATR behavior

**NOTE:** Parameter settings that reduce the atrial sensing window may inhibit ATR therapy.  
 Boston Scientific Confidential. Unauthorized use is prohibited.

LIT APPROVAL - INGENIO 1-2 MRI REF GUIDE US

### ATR Trigger Rate

The ATR Trigger Rate determines the rate at which the pulse generator begins to detect atrial tachycardias.

The pulse generator monitors atrial events throughout the pacing cycle, except during the atrial blanking period and the noise rejection intervals. Atrial events faster than the Trigger Rate increase the ATR detection counter; atrial events slower than the Trigger Rate decrease the counter.

When the ATR detection counter reaches the programmed entry count, the ATR Duration begins. When the ATR detection counter counts down from the programmed Exit Count value to zero at any point in time, ATR Duration and/or fallback are terminated, and the ATR algorithm is reset. An event marker is generated whenever the ATR detection counter is incremented or decremented.

### ATR Duration

ATR Duration is a programmable value that determines the number of ventricular cycles during which the atrial events continue to be evaluated after initial detection (entry count) is met. This feature is intended to avoid mode switching due to short, nonsustained episodes of atrial tachycardia. If the ATR counter reaches zero during ATR Duration, the ATR algorithm will be reset, and no mode switch will occur.

If the atrial tachycardia persists for the programmed ATR Duration, then mode switching occurs and the Fallback Mode and Fallback Time begin.

### Entry Count

The Entry Count determines how quickly an atrial arrhythmia is initially detected.

The lower the programmable value, the fewer the fast atrial events required to fulfill initial detection. Once the number of fast atrial events detected equals the programmable Entry Count, ATR Duration begins, and the Exit Count is enabled.

**CAUTION:** Exercise care when programming the Entry Count to low values in conjunction with a short ATR Duration. This combination allows mode switching with very few fast atrial beats. For example, if the Entry Count was programmed to 2 and the ATR Duration to 0, ATR mode switching could occur on 2 fast atrial intervals. In these instances, a short series of premature atrial events could cause the device to mode switch.

### Exit Count

The Exit Count determines how quickly the ATR algorithm is terminated once the atrial arrhythmia is no longer detected.

The lower the programmed value, the more quickly the pulse generator will return to an atrial tracking mode once an atrial arrhythmia terminates. Once the number of slow atrial events detected equals the programmable Exit Count, ATR Duration and/or Fallback will be terminated, and the ATR algorithm will be reset. The ATR Exit Count is decremented by atrial events slower than the ATR Trigger Rate or by any ventricular event that occurs more than two seconds after the last atrial event.

**CAUTION:** Exercise care when programming the Exit Count to low values. For example, if the Exit Count was programmed to 2, a few cycles of atrial undersensing could cause termination of mode switching.



### Fallback Mode

Fallback Mode is the nontracking pacing mode that the pulse generator automatically switches to when ATR Duration is fulfilled.

After switching modes, the pulse generator gradually decreases the ventricular paced rate. This decrease is controlled by the Fallback Time parameter.

**NOTE:** *Dual-chamber pacing fallback mode values are only available when the Normal pacing mode is also set to dual-chamber.*

**NOTE:** *ATR Fallback mode may be programmed rate responsive even if the permanent brady mode is non-rate responsive. In this scenario, the sensor parameters will indicate “ATR Only”.*

### Fallback Time

Fallback Time controls how quickly the paced rate will decrease from the MTR to the ATR Fallback LRL during fallback. The paced rate will decrease to the highest of the sensor-indicated rate, VRR rate, or the ATR Fallback LRL.

During fallback, the following features are disabled:

- Rate Smoothing—disabled until fallback reaches the ATR Fallback LRL or the sensor-indicated rate. If VRR is enabled, then Rate Smoothing is disabled throughout the mode switch
- Rate Hysteresis
- AV Search +
- PVARP Extension

### Fallback LRL

The ATR Fallback LRL is the programmed lower rate to which the rate decreases during mode switching. The ATR Fallback LRL may be programmed higher or lower than the permanent brady LRL.

The rate will decrease to the highest among the sensor-indicated rate (when applicable), the VRR rate (if enabled), and the ATR Fallback LRL.

### End of ATR Episode

The End of ATR Episode identifies the point when the pulse generator reverts to AV-synchronous operation because the atrial arrhythmia is no longer detected.

With the termination of the arrhythmia, the ATR Exit Count decrements from its programmed value until it reaches 0. When the ATR Exit Count reaches 0, the pacing mode automatically switches to the programmed tracking mode, and AV-synchronous operation is restored.

**NOTE:** *If RYTHMIQ is enabled, the pacing mode automatically switches back to the mode that was present prior to the ATR mode switch [AAI(R) or DDD(R) mode].*

## Ventricular Rate Regulation (VRR)

This feature is available in ACCOLADE, PROPONENT, FORMIO, VITALIO, and INGENIO devices.

Boston Scientific Confidential. Unauthorized use is prohibited.

LIT APPROVAL - INGENIO 1-2 MRI REF GUIDE US

VRR is designed to reduce the V–V cycle length variability during partially conducted atrial arrhythmias by modestly increasing the ventricular pacing rate.

The VRR algorithm calculates a VRR-indicated pacing interval based on a weighted sum of the current V–V cycle length and the previous VRR-indicated pacing intervals.

- Paced intervals have more influence than sensed intervals such that paced events cause a decrease in the VRR-indicated rate.
- For sensed intervals, the VRR-indicated rate may be increased; however, the influence is tempered by the previous history.
- The VRR-indicated rate is further bound by the LRL and the VRR MPR.

When VRR is programmed on in tracking modes, it is only active when an ATR mode switch has occurred. Once the tracking mode operation resumes at the termination of the atrial arrhythmia, VRR becomes inactive. In tracking modes where both Rate Smoothing and VRR are programmed on, Rate Smoothing is disabled when VRR is active during ATR and re-enabled once the ATR terminates.

When programmed on in nontracking modes, VRR is continually active and updates the VRR-indicated pacing rate and the smoothed average on each cardiac cycle.

#### **Ventricular Rate Regulation Maximum Pacing Rate (VRR MPR)**

The VRR MPR limits the maximum pacing rate for VRR.

VRR operates between the LRL and the MPR.

### **Atrial Flutter Response (AFR)**

This feature is available in ACCOLADE, PROPONENT, FORMIO, VITALIO, and INGENIO devices.

Atrial Flutter Response is designed to:

- Prevent pacing into the vulnerable period following an atrial sense. Pacing into the vulnerable period could occur if an atrial pace is scheduled soon after a refractory atrial sense.
- Provide immediate nontracking of atrial rates higher than the AFR Trigger Rate.

The nontracking behavior is maintained for as long as atrial events continually exceed the AFR Trigger Rate.

*Example:* When AFR is programmed to 170 ppm, a detected atrial event inside the PVARP or a previously triggered AFR interval starts an AFR window of 353 ms (170 ppm). Atrial detection inside the AFR is classified as a sense within the refractory period and is not tracked. Atrial tracking may only occur after both PVARP and the AFR window expire. Paced atrial events scheduled inside an AFR window are delayed until the AFR window expires. If there are fewer than 50 ms remaining before the subsequent ventricular pace, the atrial pace is inhibited for the cycle.

Ventricular pacing is not affected by AFR and will take place as scheduled. The wide programmable range for AFR Trigger rates allows for appropriate sensing of slow atrial flutters. High-rate atrial sensing may continuously retrigger the AFR window, effectively resulting in behavior similar to the VDI(R) fallback mode.

**NOTE:** For atrial arrhythmias that meet the programmed AFR rate criteria, using the AFR feature will result in slower ventricular pacing rates.

**NOTE:** When both AFR and ATR are active in the presence of atrial arrhythmias, nontracking ventricular paced behavior may occur sooner, but the ATR Mode Switch may take longer. This is because the ATR Duration feature counts ventricular cycles for meeting duration and the AFR feature slows the ventricular paced response to fast atrial arrhythmias.

## PMT Termination

This feature is available in ACCOLADE, PROPONENT, ESSENTIO, ALTRUA 2, FORMIO, VITALIO, INGENIO, and ADVANTIO devices.

PMT Termination detects and attempts to interrupt pacemaker-mediated tachycardia (PMT) conditions.

AV synchrony may be lost for many reasons, including atrial fibrillation, PVCs, PACs, atrial oversensing, or loss of atrial capture. If the patient has an intact retrograde conduction pathway when AV synchrony is lost, the unsynchronized beat may conduct retrograde to the atrium, resulting in premature atrial depolarization. In DDD(R) and VDD(R) pacing modes, the device may detect and track retrograde conducted P-waves that fall outside of PVARP. The repeated cycle of sensing and tracking retrograde conduction is known as PMT, which can result in triggered ventricular pacing rates as high as the MTR. Programming certain refractory periods (e.g., PVARP after PVC) can reduce the likelihood of tracking retrograde events. Rate Smoothing can also be useful in controlling the pulse generator's response to retrograde conduction.

When the pulse generator's response to retrograde conduction has not been controlled by device programming, PMT Termination (when programmed to On) is used to detect and terminate PMT within 16 cycles of onset when the following conditions have been met:

- 16 successive ventricular paces are counted at the MTR following atrial sensed events
- All 16 V–A intervals are within 32 ms (preceding or following) of the second V–A interval measured at MTR during the 16 ventricular paced events (to distinguish Wenckebach behavior from PMT)

When both conditions are met, the pulse generator sets the PVARP to a fixed setting of 500 ms for one cardiac cycle in an attempt to break the PMT. If both conditions are not met, the pulse generator continues to monitor successive ventricular paces for the presence of a PMT.

When PMT Termination is programmed to On, the pulse generator stores PMT episodes in the Arrhythmia Logbook.

**NOTE:** Although the V–A interval evaluation helps discriminate true PMT (stable V–A intervals) from upper rate behavior due to sinus tachycardia or normal exercise response (typically unstable V–A intervals), it is possible that a patient's intrinsic atrial rate can meet PMT detection criteria. In such cases, if PMT Termination is programmed On, the algorithm will declare the rhythm a PMT and extend PVARP on the 16th cycle.

**NOTE:** Because retrograde conduction times may vary over a patient's lifetime due to their changing medical condition, occasional programming changes may be necessary.

If retrograde conduction is evident in a stored EGM, you can evaluate the electrogram and/or perform a threshold test to confirm appropriate atrial pacing and sensing. If stored EGMs are not available for review, follow these steps to use the PRM to assist in V–A interval evaluation:

1. From the Tests screen, select the Temp Brady tab.
2. Program an appropriate atrial sensing mode that provides atrial markers (VDD, DDD, or DDI).
3. Program the maximum PVARP to a value shorter than the average retrograde conduction time.

**NOTE:** *Scientific literature suggests that the average retrograde conduction time is  $235 \pm 50$  ms (with a range of 110–450 ms).<sup>3</sup>*

4. Program the LRL to ensure pacing above the intrinsic atrial rate (e.g., 90, 100, 110...).
5. Begin printing the real-time ECG.
6. Select the Start button to activate the temporary parameters.
7. When testing is complete for the specified LRL value, select the Stop button.
8. Stop printing the real-time ECG.
9. Evaluate the ECG strip for V–A conduction (VP followed by an AS). Look for stable and consistent intervals suggestive of retrograde conduction.
  - If retrograde conduction was identified, compare the retrograde V–A interval time to the programmed refractory period. Consider programming PVARP to the appropriate value so that the retrograde event is not tracked.
  - If retrograde conduction was not identified, the PMT episode may be a result of normal upper rate behavior. Review Histograms to see how often the rate is at the MTR, and consider raising the MTR (if clinically appropriate).
10. If necessary, repeat this procedure with different LRL values, as retrograde conduction may occur at different rates.

## RATE ENHANCEMENTS

### Rate Hysteresis

This feature is available in ACCOLADE, PROPONENT, ESSENTIO, ALTRUA 2, FORMIO, VITALIO, INGENIO, and ADVANTIO devices.

Rate Hysteresis can improve device longevity by reducing the number of pacing stimuli. In dual-chamber models, this feature is available in DDD, DDI, VVI, and AAI modes. In single-chamber models, this feature is available in VVI and AAI modes. In DDD, DDI, and AAI modes, Rate Hysteresis is activated by a single nonrefractory atrial sensed event.

**NOTE:** *Rate Hysteresis is activated and deactivated by ventricular events in VVI mode (e.g., intrinsic activity, paced activity).*

3. Furman S, Hayes D.L., Holmes D.R., A Practice of Cardiac Pacing. 3rd ed. Mount Kisco, New York: Futura Publishing Co.; 1993:74-75.

Boston Scientific Confidential. Unauthorized use is prohibited.

LIT APPROVAL - INGENIO 1-2 MRI REF GUIDE US

In DDD, DDI, and AAI modes, Hysteresis is deactivated by a single atrial pace at the Hysteresis Rate. In DDD mode, Hysteresis is deactivated by an atrial rate above the MTR.

When Rate Smoothing Down is enabled, Rate Hysteresis remains in effect until pacing occurs at the Hysteresis Rate. This allows Rate Smoothing to control the transition to the Hysteresis Rate.

### Hysteresis Offset

Hysteresis Offset is used to lower the escape rate below the LRL when the pulse generator senses intrinsic atrial activity.

If intrinsic activity below the LRL occurs, then Hysteresis Offset allows inhibition of pacing until the LRL minus Hysteresis Offset is reached. As a result, the patient might benefit from longer periods of sinus rhythm.

### Search Hysteresis

When Search Hysteresis is enabled, the pulse generator periodically lowers the escape rate by the programmed Hysteresis Offset in order to reveal potential intrinsic atrial activity below the LRL. The programmed number of search cycles must be consecutively atrial paced for a search to occur.

*Example:* At a rate of 70 ppm and a search interval of 256 cycles, a search for intrinsic atrial activity would occur approximately every 3.7 minutes ( $256 \div 70 = 3.7$ ).

During Search Hysteresis, the pacing rate is lowered by the Hysteresis Offset for up to 8 cardiac cycles. If intrinsic activity is sensed during the search period, Hysteresis will remain active until an atrial pace occurs at the hysteresis offset rate.

Rate Smoothing is disabled during the search cycles. If no intrinsic atrial activity is detected during the 8-cycle search, the pacing rate is brought up to the LRL. Rate Smoothing Up, if enabled, controls the pacing rate increase.

## Rate Smoothing

This feature is available in ACCOLADE, PROPONENT, ESSENTIO, ALTRUA 2, FORMIO, VITALIO, INGENIO, and ADVANTIO devices.

Rate Smoothing controls the pulse generator's response to atrial and/or ventricular rate fluctuations that cause sudden changes in pacing intervals. Rate Smoothing is an important enhancement to ATR because it can significantly reduce the rate fluctuations associated with the onset and cessation of atrial arrhythmias.

Without Rate Smoothing, a sudden, large atrial rate increase will cause a simultaneous sudden increase in the paced ventricular rate as high as the programmed MTR. Patients who experience large variations in their ventricular paced rate can feel symptomatic during these episodes. Rate Smoothing can prevent these sudden rate changes and the accompanying symptoms (such as palpitations, dyspnea, and dizziness).

In a normal conduction system, limited cycle-to-cycle rate variations occur. However, the paced rate can change dramatically from one beat to the next in the presence of any of the following:

- Sinoatrial disease such as sinus pause or arrest, sinoatrial block, and brady-tachy syndrome
- PACs and/or PVCs
- Pacemaker Wenckebach

Boston Scientific Confidential. Unauthorized use is prohibited.

**LIT APPROVAL - INGENIO 1-2 MRI REF GUIDE US**

- Intermittent, brief, self-terminating SVTs, and atrial flutter/fibrillation
- Retrograde P-waves
- Pulse generator sensing of myopotential signals, EMI, crosstalk, etc.

In single-chamber modes, Rate Smoothing operates between:

- The LRL and the MPR when programmed VVI or AAI
- The LRL and the MSR when programmed VVIR or AAIR

In dual-chamber modes, Rate Smoothing operates between:

- The LRL and the greater of the MSR or MTR when programmed DDD(R) or VDD(R)
- The LRL and MPR when programmed to DDI
- The LRL and MSR when programmed to DDIR

Rate Smoothing is also applicable between the Hysteresis Rate and LRL when Hysteresis is active, except during Search Hysteresis.

When Rate Smoothing is programmed to On, it is functional except:

- During the 8 cycles of rate Search Hysteresis
- During ATR Fallback until fallback reaches the ATR LRL, the sensor-indicated rate, or the VRR interval
- During VRR when active
- Upon triggering PMT Termination
- Immediately following programmed LRL increases
- When the intrinsic rate is above the MTR

**NOTE:** *Rate Smoothing cannot be programmed to On when Sudden Brady Response is programmed to On.*

### Programmable Values

Rate Smoothing values are a percentage of the RV R–R interval (3% to 25% in 3% increments) and can be independently programmed for:

- Increase—Rate Smoothing Up
- Decrease—Rate Smoothing Down
- Off

The pulse generator stores the most recent R–R interval in memory. R-waves may be either intrinsic or paced. Based on this R–R interval and the programmed Rate Smoothing value, the device limits the variation in paced rate on a beat to beat basis.

It is important to ascertain the patient's physiologic cycle-to-cycle variation and program the Rate Smoothing parameter to a value that protects against pathologic interval changes, yet allows physiologic interval changes in response to increases in activity or exercise.

### Rate Smoothing Up

Rate Smoothing Up controls the largest pacing rate increase allowed when the intrinsic or sensor rate is increasing.

### Rate Smoothing Down

Rate Smoothing Down controls the largest pacing rate decrease allowed when the intrinsic or sensor rate is decreasing.

**NOTE:** When Rate Smoothing Down is programmed On and Rate Smoothing Up is programmed Off, the pulse generator will automatically prevent fast intrinsic beats (e.g., PVCs) from resetting the Rate Smoothing Down escape rate any faster than 12% per cycle.

### Rate Smoothing Maximum Pacing Rate (MPR)

The Rate Smoothing Maximum Pacing Rate places a limit on the maximum pacing rate that Rate Smoothing can reach.

The Rate Smoothing Down parameter requires a programmed MPR when in AAI, VVI, or DDI. Rate Smoothing will then be used only between the MPR and the LRL or the Hysteresis Rate (if applicable).

When both VRR and Rate Smoothing are programmed on in the VVI(R) or DDI(R) mode, VRR will have priority.

## Rate Smoothing Example Based on a Dual-Chamber Tracking Mode

Based on the most recent R–R interval stored in memory and the programmed Rate Smoothing value, the pulse generator sets up the two synchronization windows for the next cycle: one for the atrium and one for the ventricle. The synchronization windows are defined below:

Ventricular synchronization window: previous R–R interval  $\pm$  Rate Smoothing value

Atrial synchronization window: (previous R–R interval  $\pm$  Rate Smoothing value) - AV Delay

The following example explains how these windows are calculated (Figure 2-30 on page 2-52):

- Previous R–R interval = 800 ms
- AV Delay = 150 ms
- Rate Smoothing Up = 9%
- Rate Smoothing Down = 6%

The windows would be calculated as follows:

Ventricular Synchronization Window = 800 - 9% to 800 + 6% = 800 ms - 72 ms to 800 ms + 48 ms = 728 ms to 848 ms

Atrial Synchronization Window = Ventricular Synchronization Window - AV Delay = 728 ms - 150 ms to 848 ms - 150 ms = 578 ms to 698 ms

Boston Scientific Confidential. Unauthorized use is prohibited.

LIT APPROVAL - INGENIO 1-2 MRI REF GUIDE US

The timing for both windows is initiated at the end of every ventricular event (R–R interval).

If paced activity is to occur, it must occur within the appropriate synchronization window.

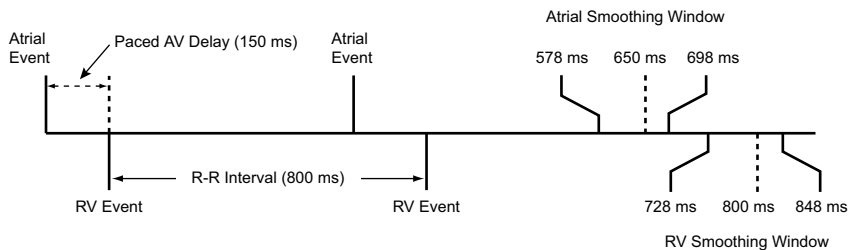

Figure 2-30. Rate smoothing synchronization window

## Sudden Brady Response (SBR)

This feature is available in ACCOLADE, PROPONENT, ESSENTIO, ALTRUA 2, FORMIO, VITALIO, and INGENIO devices.

Sudden Brady Response (SBR) is designed to respond to sudden decreases in intrinsic atrial rates by applying pacing at an elevated rate.

SBR is available in DDD(R) modes. SBR is declared when the atrial chamber has been continuously sensed for one minute (nonprogrammable), followed by a sudden decrease in atrial rate such that atrial pacing occurs at the LRL or the sensor-indicated rate for a programmable number of cycles. The decrease in atrial rate preceding the paced events must exceed 10 bpm (nonprogrammable).

The SBR algorithm continually monitors the average of the atrial rate and this average is updated each cardiac cycle. This average rate is used both to determine if the atrial rate has decreased more than 10 bpm and to determine the rate of SBR therapy.

**NOTE:** Sudden Brady Response is not available when Rate Smoothing is enabled.

**NOTE:** Sudden Brady Response will not be activated based on an atrial rate decrease during ATR Fallback.

**NOTE:** Sudden Brady Response will not be activated based on an atrial rate decrease while RYTHMIQ is operating in AAI(R) mode. If RYTHMIQ is operating in DDD(R) mode, a successful AV Search will terminate SBR therapy.

### SBR Atrial Paces Before Therapy

The SBR Atrial Paces Before Therapy criteria are applied once the decrease in atrial rate has been detected and LRL or sensor-indicated rate pacing begins. Atrial pacing must occur for the programmable number of consecutive intervals before the SBR criteria are met. This parameter is used to ensure that the rate stays at the LRL or sensor-indicated rate prior to delivering therapy. If atrial senses occur during these intervals, the algorithm is reset and SBR therapy is not applied.

### SBR Atrial Pacing Rate Increase

SBR Atrial Pacing Rate Increase is calculated by using the patient's average atrial rate before the drop in rate and adding a programmable positive offset (Figure 2-31 on page 2-53).



Pacing is applied in the DDD(R) mode at whichever of the following rates is higher:

- The previous average atrial rate plus the SBR Atrial Pacing Rate Increase (not to exceed the MTR), or
- The sensor-indicated rate (DDDR mode only)

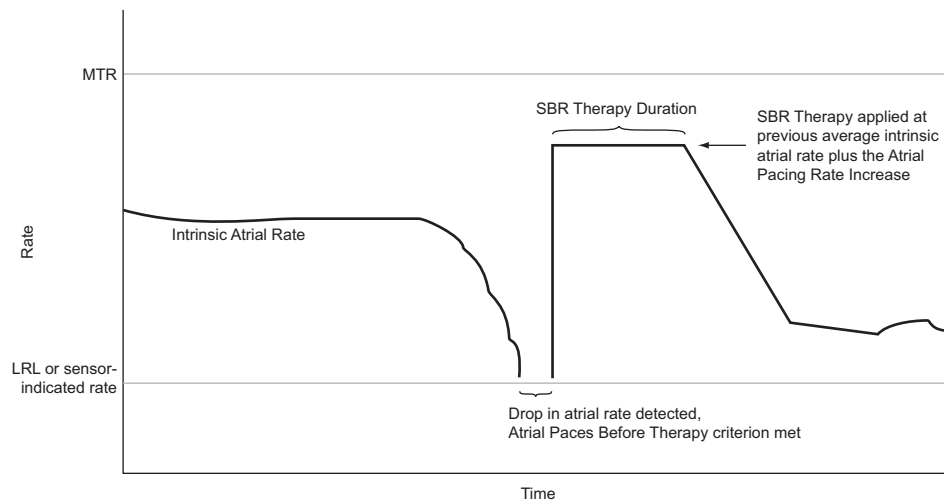

Figure 2-31. Sudden Brady Response

### SBR Therapy Duration

SBR Therapy Duration is the programmable time interval during which the SBR pacing therapy rate will be applied. Once pacing therapy has been delivered, the atrial pacing rate will be decreased using a 12% Rate Smoothing Down factor (nonprogrammable) until the LRL or sensor-indicated rate is reached.

**NOTE:** Rate Hysteresis is not active during SBR Therapy Duration.

**NOTE:** SBR Therapy Duration will end if a manual or PaceSafe Threshold Test is performed.

### SBR Inhibit During Rest

SBR Inhibit During Rest is designed to distinguish between a natural drop in rate (sleep) and a pathologic drop. It provides the ability to inhibit SBR therapy when the SBR rate and duration criteria are met, but the patient's current MV measurement is lower than an MV comparison value. The MV sensor must be set to On or Passive for the SBR Inhibit During Rest to be programmed On. When MV is activated, the pulse generator determines the lowest measured MV baseline value for each day over a 1-week period (rolling 7-day window). The MV comparison value is then set to 50% above that lowest weekly MV baseline. Each day, this MV comparison value is updated so that the algorithm adjusts to long-term changes in the patient's MV baseline. In the event the SBR atrial rate and duration criteria are met, the current MV measurement is compared to the MV comparison value. If the current MV measurement is less than the comparison value, SBR therapy is inhibited (Figure 2-32 on page 2-54). If the present MV measurement is greater than or equal to the comparison value, SBR therapy is initiated (Figure 2-33 on page 2-54).

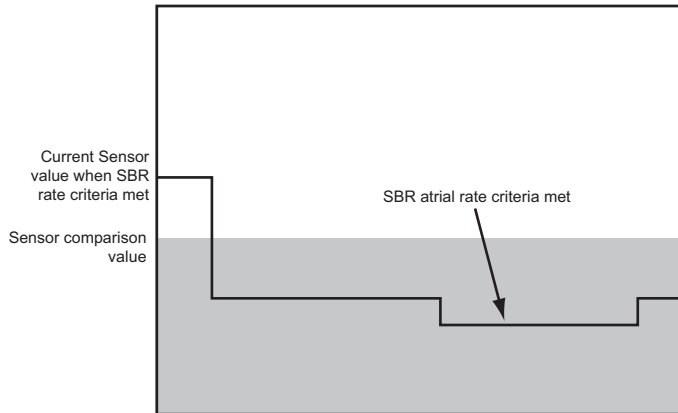

Figure 2-32. SBR Therapy Inhibited by Sensor Comparison

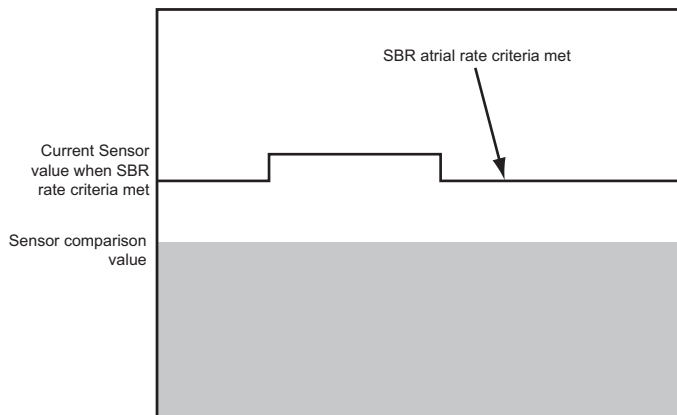

Figure 2-33. SBR Therapy Delivered after Sensor Comparison

## LEAD CONFIGURATION

This feature is available in ACCOLADE, PROPONENT, ESSENTIO, ALTRUA 2, FORMIO, VITALIO, INGENIO, and ADVANTIO devices.

The pulse generator has independently programmable lead configurations for the following:

- Atrium (in dual-chamber models)
- Right Ventricle

The atrial and RV leads may be set to Unipolar and/or Bipolar pacing and sensing. Additionally, the atrial lead can be programmed to a Bipolar or Unipolar pacing lead configuration with the atrial sensing lead configuration Off.

The input impedance is > 100 K $\Omega$  for each sense/pace electrode pair.

In dual-chamber devices programmed to AAI(R), the ventricular sensing lead configuration is available to facilitate VT detection. This parameter will be available unless the Ventricular Tachy EGM Storage parameter is set to Off.

If the atrial or ventricular lead type is specified as Unipolar on the Patient Information screen, programming to Bipolar configuration for either pacing or sensing is not allowed. Certain features

Boston Scientific Confidential. Unauthorized use is prohibited.

LIT APPROVAL - INGENIO 1-2 MRI REF GUIDE US

and programming options require a bipolar lead to be identified either in Patient Information or with a bipolar lead configuration. Therefore, if Patient Information is not entered, Unipolar programming may result in a parameter interaction.

**NOTE:** *If a unipolar pacing configuration is required at implant, ensure that the configuration is programmed to Unipolar before implant.*

**CAUTION:** If the Lead Configuration is programmed to Bipolar when a unipolar lead is implanted, pacing will not occur.

**NOTE:** *If a separate ICD is present, programming the pacemaker Lead Configuration to Unipolar is contraindicated.*

When the pacing configuration is programmed to Unipolar, the pacing stimulus will be applied between the lead tip and the pacemaker case. When the pacing configuration is programmed to Bipolar, the stimulus will be applied between the lead tip and the lead ring. In the Unipolar pacing configuration, the pacing artifact should be clearly visible on the surface ECG, which will assist in its interpretation. However, unipolar pacing at high outputs is more likely than bipolar pacing to cause muscle stimulation.

When the sensing configuration is programmed to Unipolar, cardiac signals are detected between the lead tip and the pacemaker case. In the Unipolar sensing configuration, the pacemaker can generally discern smaller intrinsic cardiac signals than in the Bipolar configuration. However, the Unipolar configuration is also more sensitive to myopotentials which can cause pacemaker inhibition. When the sensing configuration is programmed to Bipolar, because of the relatively short distance between the tip and ring electrodes, sensitivity is highest for signals originating in the proximity of the lead tip and ring. As a result, the pacemaker is less likely to sense myopotentials and other signals unrelated to cardiac depolarization.

**NOTE:** *Blanking Period behavior will vary slightly depending on which Lead Configuration is selected ("Cross-Chamber Blanking" on page 2-66).*

## Use of Atrial Information

This feature is available in ACCOLADE, PROPONENT, ESSENTIO, ALTRUA 2, FORMIO, VITALIO, INGENIO, and ADVANTIO devices.

Atrial sensing can be programmed to On or Off in any dual or single chamber Brady Mode. The pulse generator will respond to atrial sensing regardless of whether an atrial lead is implanted.

There may be clinical situations in which atrial lead information is not useful (e.g., chronic atrial fibrillation, faulty or dislodged atrial lead, plugged atrial port).

**CAUTION:** If an atrial lead is not implanted (port is plugged instead), or an atrial lead is abandoned but remains connected to the header, device programming should be consistent with the number and type of leads actually in use.

If an atrial lead will not be used, use the following programming recommendations to ensure appropriate device behavior:

- Program the Brady Mode to VVI or VVI(R), to prevent atrial pacing and ensure that atrial information is not used to drive brady pacing.

- Program the atrial sensing Lead Configuration to Off to prevent atrial sensing and minimize accrual of atrial counters. This will also disable the V>A detection enhancement [all tachy events will be labeled as VT (V>A)].

**CAUTION:** Sensing high atrial rates may impact device longevity. Therefore, the Atrial Sense lead configuration will be seeded to Off when programming from an atrial sensing mode to a non-atrial sensing mode.

**CAUTION:** When atrial sensing is programmed to Off in a DDI(R) or DDD(R) mode, any atrial pacing that occurs will be asynchronous. Additionally, features that require atrial sensing may not function as expected.

**NOTE:** *An atrial EP Test should not be performed if the atrial sensing Lead Configuration is programmed to Off.*

- Program the Atrial Intrinsic Amplitude and Atrial Pace Impedance daily lead measurements to Off to disable atrial diagnostics (e.g., Atrial Amplitude and Impedance).
- During follow-up visits, consider deselecting the atrial real-time EGM.

If an atrial lead is used in the future, these programming adjustments should be reevaluated, and the pulse generator should be programmed appropriately for use with an atrial lead.

## Lead Safety Switch

This feature is available in ACCOLADE, PROPONENT, ESSENTIO, ALTRUA 2, FORMIO, VITALIO, INGENIO, and ADVANTIO devices.

The Lead Safety Switch feature allows the pacemaker to monitor lead integrity and to switch the pacing and sensing Lead Configuration from Bipolar to Unipolar if the impedance criteria indicate unacceptably high or low lead impedances.

Lead integrity is monitored once per day by measuring lead impedance. The Safety Switch feature may be programmed to On in either the Atrium or Right Ventricle.

When the measured Impedance is less than or equal to the programmed Low Impedance Limit or greater than or equal to 2000  $\Omega$  (or the programmed High Impedance Limit) for any Daily Measurement, both pacing and sensing configurations will automatically be switched to Unipolar for that chamber. Once the configuration has switched, it will remain Unipolar until it is manually reprogrammed back to Bipolar.

**NOTE:** *Reprogramming back to Bipolar may result in unexpected behavior due to the lead integrity issue that triggered the Safety Switch.*

If a Safety Switch has occurred, information is presented in the following locations on the programmer:

- Summary dialog on initial interrogation
- Leads section of the summary tab
- Daily Measurement graph regardless of the horizontal cursor position
- Safety Switch Details button from the Leads Setting screen

The date on which the Safety Switch occurred as well as the out of range lead impedance value measured are provided. Additionally, an attention symbol is displayed next to the Pace and Sense Lead Configuration for the affected lead, with Unipolar displayed as the currently programmed parameter for that lead.

The Safety Switch lead alert messages will remain on the PRM screen until the session is ended and will not be present on subsequent sessions unless an additional Safety Switch occurs.

Further testing of lead integrity and performance may be carried out via the Lead Tests screen. Testing will be performed in Unipolar until the Lead Configuration is manually reprogrammed back to Bipolar.

**CAUTION:** If properly functioning leads with stable measured impedance values near the programmed impedance limits are used, consider programming Lead Safety Switch Off or changing the impedance limits to avoid undesirable switching to a Unipolar Lead Configuration.

**NOTE:** *Disabling daily lead impedance measurements in a given chamber also disables the Lead Safety Switch feature in that chamber.*

**WARNING:** Lead Safety Switch should be programmed Off for patients with an ICD. Unipolar pacing due to Lead Safety Switch is contraindicated for patients with an ICD.

## AV DELAY

AV Delay is the programmable time period from the occurrence of either a paced or sensed right atrial event to a paced RV event.

AV Delay is designed to help preserve the heart's AV synchrony. If a sensed right ventricular event does not occur during the AV Delay following an atrial event, the pulse generator delivers a ventricular pacing pulse when the AV Delay expires.

AV Delay can be programmed to one or both of the following operations:

- Paced AV Delay
- Sensed AV Delay

AV Delay is applicable in DDD(R), DDI(R), DOO or VDD(R) modes.

**NOTE:** *The PaceSafe Right Ventricular Automatic Capture feature may lengthen the programmed AV Delay in order to distinguish a fusion beat or noise from ventricular capture.*

**NOTE:** *Long fixed AV intervals may be selected to avoid unnecessary RV pacing. However, programming long fixed AV intervals, in some cases, may be associated with PMT, diastolic mitral insufficiency, or pacemaker syndrome. As an alternative to programming long fixed AV intervals, consider AV Search + to avoid unnecessary RV pacing.*

## Paced AV Delay

This feature is available in ACCOLADE, PROPONENT, ESSENTIO, ALTRUA 2, FORMIO, VITALIO, INGENIO, and ADVANTIO devices.

Paced AV Delay corresponds to the AV Delay following an atrial pace.

When the minimum AV Delay value is less than the maximum AV Delay value, then the Paced AV Delay is scaled dynamically according to the current pacing rate. Dynamic AV Delay provides a more

Boston Scientific Confidential. Unauthorized use is prohibited.

**LIT APPROVAL - INGENIO 1-2 MRI REF GUIDE US**

physiologic response to rate changes by automatically shortening the Paced AV Delay or Sensed AV Delay with each interval during an increase in atrial rate. This helps minimize the occurrence of large rate changes at the upper rate limit and allows one-to-one tracking at higher rates.

The pulse generator automatically calculates a linear relationship based on the interval length of the previous A–A or V–V cycle (depending on the previous event type) and the programmed values for the following:

- Minimum AV Delay
- Maximum AV Delay
- LRL
- MTR
- MSR
- MPR

The Dynamic AV Delay is not adjusted following a PVC or when the previous cardiac cycle was limited by the MTR.

If the atrial rate is at or below the LRL (e.g., hysteresis), the maximum AV Delay is used. If the atrial rate is at or above the higher of the MTR, MSR, or MPR, the programmed minimum AV Delay is used.

When the atrial rate is between the LRL and the higher of the MTR, MSR, and MPR, the pulse generator calculates the linear relationship to determine the Dynamic AV Delay.

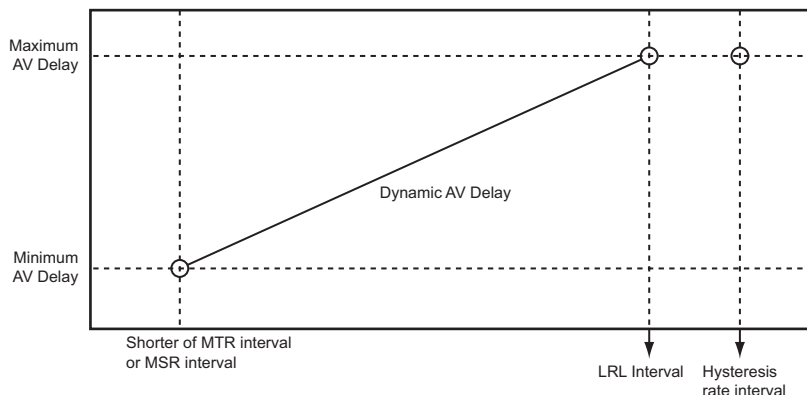

**Figure 2-34. Dynamic AV Delay**

The AV Delay may be programmed to either a fixed or dynamic value as follows:

- Fixed AV Delay—occurs when Paced AV Delay minimum and maximum values are equal
- Dynamic AV Delay—occurs when Paced AV Delay minimum and maximum values are not equal

## Sensed AV Delay

This feature is available in ACCOLADE, PROPONENT, ESSENTIO, ALTRUA 2, FORMIO, VITALIO, INGENIO, and ADVANTIO devices.

Sensed AV Delay corresponds to the AV Delay after a sensed atrial event.

Boston Scientific Confidential. Unauthorized use is prohibited.

LIT APPROVAL - INGENIO 1-2 MRI REF GUIDE US

Sensed AV Delay may be programmed to a value shorter than or equal to the Paced AV Delay. A shorter value is intended to compensate for the difference in timing between paced atrial events and sensed atrial events (Figure 2-35 on page 2-59).

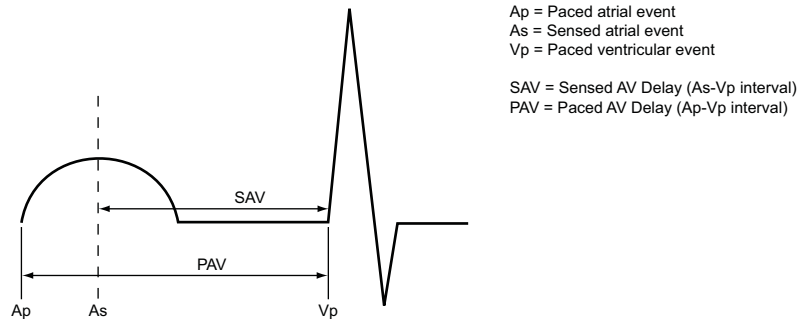

**Figure 2-35. Sensed AV Delay**

The hemodynamic impact of the Sensed AV Delay depends on the appropriateness of the timing between the atrial and ventricular contractions. Atrial pacing initiates atrial electrical excitation, whereas atrial sensing can only occur after the onset of spontaneous atrial excitation. The delay between initiation and sensing depends on the lead location and conduction. As a result, when Sensed AV Delay is programmed to the same value as Paced AV Delay, the hemodynamic AV interval will differ between paced and sensed atrial events.

When the device is programmed to DDD(R), it is recommended that the patient be tested to determine the optimal AV Delay during atrial sensing and atrial pacing. If the optimal AV Delays are different, this can be reflected by programming different Paced AV Delay and Sensed AV Delay parameter settings.

#### **Using Sensed AV Delay with Paced AV Delay—Fixed**

When Paced AV Delay is programmed to a fixed value, then the Sensed AV Delay will be fixed at the programmed Sensed AV Delay value.

#### **Using Sensed AV Delay with Paced AV Delay—Dynamic**

When Paced AV Delay is programmed as dynamic, then the Sensed AV Delay will also be dynamic.

Dynamic Sensed AV Delay and Paced AV Delay are based on the atrial rate. To reflect the shortening of the PR interval during periods of increased metabolic demand, the AV Delay shortens linearly from the programmed (maximum) value at the LRL (or hysteresis rate) to a value determined by the ratio of minimum and maximum AV Delay at the higher of the MTR, MSR, or MPR (Figure 2-36 on page 2-60). When Dynamic AV Delay is used, if the maximum Sensed AV Delay value is programmed as shorter than the maximum Paced AV Delay value, then the minimum Sensed AV Delay value will also be shorter than the minimum Paced AV Delay value.

**NOTE:** *The minimum Sensed AV Delay value is programmable only in VDD(R) mode.*

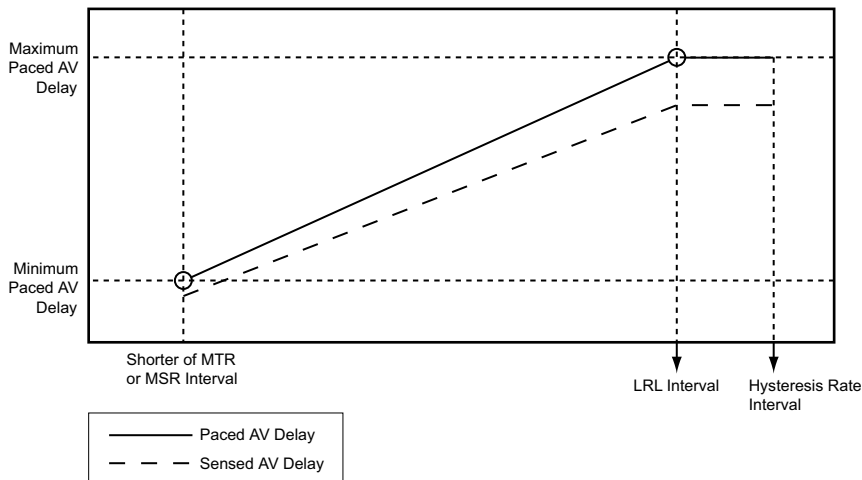

Figure 2-36. Dynamic and Sensed AV Delay function

## AV Search +

This feature is available in ACCOLADE, PROPONENT, ESSENTIO, ALTRUA 2, FORMIO, VITALIO, INGENIO, and ADVANTIO devices.

AV Search + is designed to promote intrinsic A–V conduction if present by allowing AV conduction to occur beyond the programmed AV Delay. In patients with exercise-dependent, first degree or second degree AV nodal block, this intrinsic AV conduction can improve hemodynamic performance and increase device longevity by reducing the amount of ventricular pacing pulses.

When AV Search + is enabled, the AV Delay is lengthened periodically (Search Interval) for up to 8 consecutive paced or sensed cardiac cycles. The AV Search + AV Delay remains active as long as the intrinsic PR intervals are shorter than the programmed Search AV Delay value.

The pulse generator reverts to the programmed AV Delay at the following points:

- When the 8-cycle search expires without sensing intrinsic ventricular activity
- When two ventricular paced events occur within a 10-cycle moving window

### Search AV Delay

The Search AV Delay parameter determines the length of the sensed and paced AV delays during the search cycles and during the AV hysteresis period.

The PaceSafe Right Ventricular Automatic Capture feature may lengthen the programmed AV Delay in order to distinguish a fusion beat or noise from ventricular capture.

**NOTE:** The Search AV Delay value must be programmed to longer than the maximum Paced AV Delay. Dynamic AV Delay and Sensed AV Delay are not applied during AV Search +.

The PRM does not consider the AV Delay associated with AV Search + when calculating the TARP interval. This is so that longer AV Delays, without interactions, can be programmed for patients with intact AV conduction. Note that if AV Search + is utilized in this manner, Wenckebach-like behavior may occur at rates lower than the MTR if conduction is lost.



**NOTE:** Long fixed AV intervals may be selected to avoid unnecessary RV pacing. However, programming long fixed AV intervals, in some cases, may be associated with PMT, diastolic mitral insufficiency or pacemaker syndrome. As an alternative to programming long fixed AV intervals, consider AV Search + to avoid unnecessary RV pacing.

### Search Interval

The Search Interval controls the frequency at which AV Search + will attempt a search.

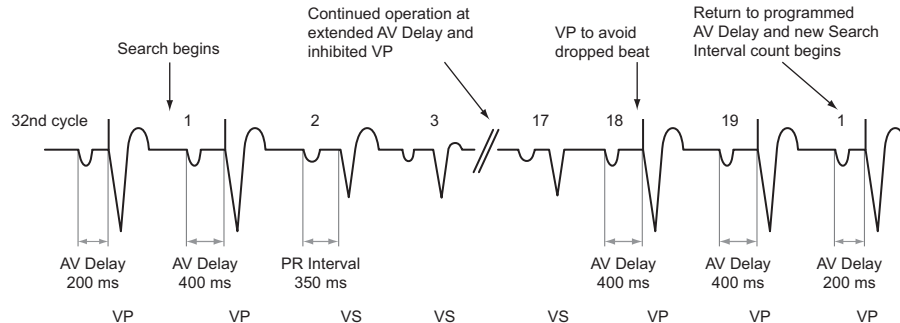

Figure 2-37. AV Search +

## RYTHMIQ

This feature is available in ACCOLADE, PROPONENT, FORMIO, VITALIO, and INGENIO devices.

RYTHMIQ reduces unnecessary ventricular pacing<sup>4</sup> and prevents clinically significant pauses as defined by the 2008 ACC/AHA/HRS guidelines<sup>5</sup>. RYTHMIQ operates in an AAI(R) pacing mode with VVI backup during times of normal conduction. If loss of AV synchrony is detected, then the mode automatically switches to DDD(R) to restore AV synchrony. If normal conduction returns, then the mode automatically switches back to AAI(R) with VVI backup. RYTHMIQ does not require dropped ventricular beats to switch to DDD(R) pacing.

RYTHMIQ is available only when the Normal Brady Mode is programmed to DDD(R). If the Normal Brady Mode is DDD, then RYTHMIQ can be set to either AAI With VVI Backup or Off. If the Normal Brady Mode is DDDR, then RYTHMIQ can be set to either AAIR With VVI Backup or Off.

The following occurs during the RYTHMIQ stage of AAI(R) with VVI backup:

- The device provides AAI(R) pacing at the LRL and/or sensor indicated rate.
- The device provides backup VVI pacing at a rate of 15 ppm slower than the LRL. The backup VVI pacing rate is limited to no slower than 30 ppm and no faster than 60 ppm. When there is consistent conduction, ventricular pacing does not occur as the VVI backup mode runs in the background at a reduced LRL.

4. Tolosana JM, Gras D, Le Polain De Waroux JB, et al. Reduction in right ventricular pacing with a new reverse mode switch algorithm: results from the IVORY trial. *Europace*. 2013;15 (suppl 2):P1036.

5. ACC/AHA/HRS 2008 Guidelines for Device-Based Therapy of Cardiac Rhythm Abnormalities. *Journal of the American College of Cardiology*, Vol. 51(21), May 27, 2008.

Boston Scientific Confidential. Unauthorized use is prohibited.

- The device monitors for loss of AV synchrony. If 3 slow ventricular beats are detected in a window of 11 beats, then the device automatically switches to DDD(R) mode. A slow beat for RYTHMIQ is defined as a ventricular pace or ventricular sensed event that is at least 150 ms slower than the AAI(R) pacing interval.

The following occurs during the RYTHMIQ stage of DDD(R):

- The device provides DDD(R) pacing according to the normal programmed parameters.
- The device uses AV Search + to periodically check for a return of intrinsic conduction. If AV Search + remains in AV hysteresis for at least 25 cardiac cycles, and less than 2 of the last 10 cycles are ventricular paced, then the device automatically switches the pacing mode back to AAI(R) with VVI backup.

When RYTHMIQ detects loss of AV synchrony, the device records a RYTHMIQ episode along with 20 seconds of electrogram data (10 seconds before the mode switch, 10 seconds after the mode switch). The RYTHMIQ episode will be noted by the PRM and can be inspected in detail by selecting the appropriate episode from the Arrhythmia Logbook screen. When the DDD(R) stage of RYTHMIQ is active, the RYTHMIQ episode is identified as "In Progress".

Features available during the DDD(R) stage of RYTHMIQ may not be available during the AAI(R) stage of RYTHMIQ. The exceptions are ATR, Rate Adaptive Pacing, and Rate Smoothing. If ATR is programmed on for DDD(R), it will also be active during AAI(R), and may perform an ATR Mode Switch from either RYTHMIQ stage. When the atrial arrhythmia ends, the pacing mode will resume the RYTHMIQ stage that was active before the ATR Mode Switch. If Rate Smoothing is programmed On for DDD(R), then Rate Smoothing will be active during AAI(R); Rate Smoothing will not alter the VVI backup-pacing rate.

**NOTE:** *Sudden Brady Response will not be activated based on an atrial rate decrease while RYTHMIQ is operating in AAI(R) mode. If RYTHMIQ is operating in DDD(R) mode, a successful AV Search will terminate SBR therapy.*

If you want the switch from AAI(R) with VVI Backup to DDD(R) to only occur once, then program AV Search + to Off. In this case, the pulse generator remains in DDD(R) mode until reprogramming occurs.

## REFRACTORY

This feature is available in ACCOLADE, PROPONENT, ESSENTIO, ALTRUA 2, FORMIO, VITALIO, INGENIO, and ADVANTIO devices.

Refractory periods are the intervals following paced or sensed events during which the pulse generator is not inhibited or triggered by detected electrical activity. They suppress (or prevent) oversensing of pulse generator artifacts and evoked responses following a pacing pulse. They also promote appropriate sensing of a single, wide, intrinsic complex and prevent the sensing of other intrinsic signal artifacts (e.g., a T-wave or far-field R-wave).

**NOTE:** *Rate Adaptive Pacing is not inhibited during refractory periods.*

**NOTE:** *Single-chamber devices programmed to VVI(R) will automatically load ventricular-specific refractory periods, and single-chamber devices programmed to AAI(R) will automatically load atrial-specific refractory periods. As discussed below, the atrial refractory periods used in a single-chamber device are different from those used in a dual-chamber device.*

## A-Refractory - PVARP

PVARP is defined according to the pacing mode:

- Dual-chamber device programmed AAI(R)—the time period after a sensed or paced atrial event when an atrial sense event does not inhibit an atrial pace.
- Dual-chamber modes: DDD(R), DDI(R), VDD(R)—the time period after a sensed or paced RV event when an atrial event does not inhibit an atrial pace or trigger a ventricular pace. The Atrial Refractory period prevents the tracking of retrograde atrial activity initiated in the ventricle.

PVARP can be programmed to a fixed value or to a dynamic value calculated based on the previous cardiac cycles. To program a fixed PVARP, set the minimum and maximum to the same value. PVARP will automatically be dynamic if the minimum value is less than the maximum value.

A long Atrial Refractory period shortens the brady atrial sensing window. Programming long Atrial Refractory periods in combination with certain AV Delay periods can cause 2:1 block to occur abruptly at the programmed MTR.

In DDD(R) and VDD(R) pacing modes, the pulse generator may detect retrograde conduction in the atrium, causing triggered ventricular pacing rates as high as the MTR (i.e., PMT). Retrograde conduction times may vary over a patient's lifetime as a function of changing autonomic tone. If testing does not reveal retrograde conduction at implantation, it may still occur at a later time. This problem can usually be avoided by increasing the atrial refractory period to a value that exceeds the retrograde conduction time.

In controlling the pulse generator's response to retrograde conduction, it may also be useful to program the following:

- PVARP after PVC
- PMT Termination
- Rate Smoothing

### Dynamic PVARP

This feature is available in ACCOLADE, PROPONENT, ESSENTIO, ALTRUA 2, FORMIO, VITALIO, INGENIO, and ADVANTIO devices.

Programming of Dynamic PVARP and Dynamic AV Delay optimizes the sensing window at higher rates, allowing upper rate behavior (e.g., 2:1 block and pacemaker Wenckebach) in DDD(R) and VDD(R) modes to be significantly reduced, even at higher MTR settings. At the same time, Dynamic PVARP reduces the likelihood of PMTs at lower rates. Dynamic PVARP also reduces the likelihood of competitive atrial pacing.

The pulse generator automatically calculates the Dynamic PVARP using a weighted average of the previous cardiac cycles. This results in a shortening of the PVARP in a linear fashion as the rate increases. When the average rate is between the LRL and the MTR or applicable upper rate limit, the pulse generator calculates the Dynamic PVARP according to the linear relationship shown (Figure 2-38 on page 2-64). This relationship is determined by the programmed values for Minimum PVARP, Maximum PVARP, the LRL, and the MTR or applicable upper rate limit.

**CAUTION:** Programming minimum PVARP less than retrograde V–A conduction may increase the likelihood of a PMT.

Boston Scientific Confidential. Unauthorized use is prohibited.

LIT APPROVAL - INGENIO 1-2 MRI REF GUIDE US

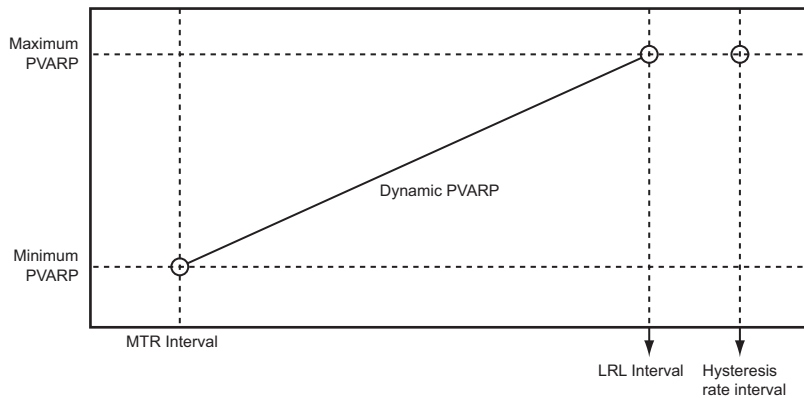

Figure 2-38. Dynamic PVARP

### Maximum PVARP

If the average rate is equal to or lower than the LRL (e.g., hysteresis), the Maximum PVARP is used.

### Minimum PVARP

If the average rate is equal to or higher than the MTR interval, the programmed Minimum PVARP is used.

### PVARP after PVC

PVARP after PVC is designed to help prevent PMT due to retrograde conduction, which can occur due to a PVC.

When the pulse generator detects a sensed RV event without detecting a preceding atrial sensed event (refractory or non-refractory) or delivering an atrial pace, the Atrial Refractory period automatically extends to the programmed PVARP after PVC value for one cardiac cycle. After a PVC is detected, the timing cycles reset automatically. PVARP extends no more frequently than every other cardiac cycle.

The pulse generator automatically extends the PVARP to the PVARP after PVC value for one cardiac cycle in these additional situations:

- If an atrial pace is inhibited due to Atrial Flutter Response
- After a ventricular escape pace that is not preceded by an atrial sense in VDD(R) mode
- When the device transitions from a non-atrial tracking mode to an atrial tracking mode (e.g., exits ATR Fallback, transitions from temporary non-atrial tracking mode to permanent atrial tracking mode)
- When the device returns from magnet operation to an atrial tracking mode
- When the device returns from Electrocautery Protection Mode or MRI Protection Mode to an atrial tracking mode

## A Refractory - same chamber

### Dual-chamber Modes

Atrial Refractory provides an interval following an atrial paced or sensed event when additional atrial sensed events do not impact the timing of pacing delivery.

The following are nonprogrammable intervals for dual-chamber modes:

- 85 ms Atrial Refractory following an atrial sensed event
- 150 ms Atrial Refractory following an atrial pace in DDD(R) and DDI(R) modes

### Single-chamber Device

In a single-chamber device programmed to AAI(R), there is a programmable refractory period following atrial events. This is applied to both atrial pace and atrial sense events to ensure there is a long enough refractory period to prevent oversensing of a far-field ventricular event. Any sensed event which falls into refractory is not detected or marked, and does not impact timing cycles, unless it occurs within the noise window.

**NOTE:** *If prolonged intrinsic conduction is present, a longer refractory may be needed to avoid oversensing a far-field R-wave.*

## RV-Refractory (RVRP)

The programmable RVRP provides an interval following an RV pace event during which RV sensed events do not impact the timing of pacing delivery.

Additionally, a 135 ms nonprogrammable refractory period provides an interval following an RV sensed event during which further RV sensed events do not impact the timing of pacing delivery.

The programming and function of the Ventricular Refractory Period in VVI(R) mode is the same in dual- and single-chamber devices. Any event which falls into VRP is not detected or marked (unless it occurs within the noise window), and does not impact timing cycles.

RVRP is available in any mode where ventricular sensing is enabled, and RVRP can be programmed to a fixed or dynamic interval (Figure 2-39 on page 2-66):

- Fixed—RVRP remains at the programmed, fixed RVRP value between the LRL and the applicable upper rate limit (MPR, MTR or MSR).
- Dynamic—RVRP shortens as ventricular pacing increases from the LRL to the applicable upper rate limit, allowing adequate time for RV sensing.
  - Maximum—if the pacing rate is less than or equal to the LRL (i.e., hysteresis), the programmed Maximum VRP is used as the RVRP.
  - Minimum—if the pacing rate is equal to the applicable upper rate limit, the programmed Minimum VRP is used as the RVRP.

**NOTE:** *Dynamic Refractory is not available in single-chamber devices programmed to VVI if there is no Max Pacing Rate to apply the minimum value, or any time in single-chamber devices programmed to AAI(R).*

Boston Scientific Confidential. Unauthorized use is prohibited.

LIT APPROVAL - INGENIO 1-2 MRI REF GUIDE US

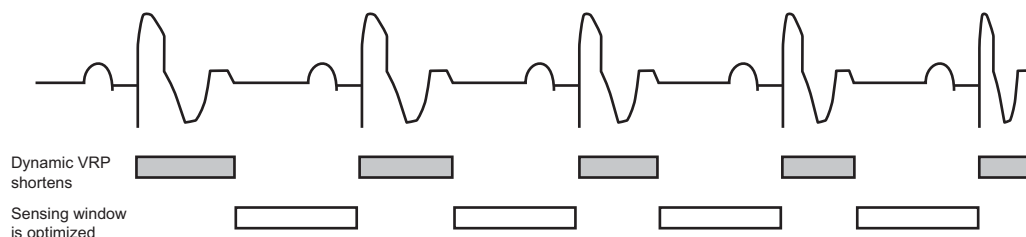

**Figure 2-39.** Relationship between ventricular rate and refractory interval

To provide an adequate sensing window, the following Refractory value (fixed or dynamic) programming is recommended:

- Single-chamber modes—less than or equal to one-half the LRL in ms
- Dual-chamber modes—less than or equal to one-half the applicable upper rate limit in ms

The use of a long RVRP shortens the ventricular sensing window.

Programming the Ventricular Refractory Period to a value greater than PVARP can lead to competitive pacing. For example, if the Ventricular Refractory is longer than PVARP, an atrial event can be appropriately sensed following PVARP and intrinsic conduction to the ventricle falls into the Ventricular Refractory Period. In this case, the device will not sense the ventricular depolarization and will pace at the end of the AV Delay, resulting in competitive pacing.

## Cross-Chamber Blanking

This feature is available in ACCOLADE, PROPONENT, ESSENTIO, ALTRUA 2, FORMIO, VITALIO, INGENIO, and ADVANTIO devices.

Cross-chamber blanking periods are designed to promote appropriate sensing of in-chamber events and prevent oversensing of activity in another chamber (e.g., cross-talk, far-field sensing).

Cross-chamber blanking periods are initiated by paced and/or sensed events in an adjacent chamber. For example, a blanking period is initiated in the right ventricle each time a pacing pulse is delivered to the right atrium; this prevents the device from detecting the atrial paced event in the right ventricle.

Cross-chamber Blanking can be programmed to Smart (when available) or a fixed value. Smart Blanking is designed to promote appropriate sensing of in-chamber events by shortening the cross-chamber blanking period (37.5 ms following paced events and 15 ms following sensed events) and prevent oversensing of cross-chamber events by automatically raising the AGC threshold for sensing at the expiration of the Smart Blanking period.

Smart Blanking does not change the programmed AGC or Fixed Sensitivity settings.

**NOTE:** *Smart Blanking periods will be lengthened to 85 ms if a same-chamber blanking period or a retriggerable noise window is active when the Smart Blanking period begins. For example, if an RV sense occurs within the atrial refractory period, the A-Blank after RV-Sense cross chamber blank will be 85 ms.*

**CAUTION:** Sensitivity adjustments associated with Smart Blanking may not be sufficient to inhibit detection of cross-chamber artifacts if the cross-chamber artifacts are too large. Consider other factors that impact the size/amplitude of cross-chamber artifacts including lead-placement, pacing output, and programmed Sensitivity settings.

Boston Scientific Confidential. Unauthorized use is prohibited.

LIT APPROVAL - INGENIO 1-2 MRI REF GUIDE US

Blanking period nominals and programmable options will automatically change in certain situations in order to ensure that cross-chamber artifacts are not detected:

- If the AGC Sensing Method is selected, Smart Blanking is the nominal setting (except for V-Blank after A-Pace) and Fixed Blanking is also available.

**NOTE:** *If AGC is used with a Unipolar Atrial Sense Lead Configuration, Fixed atrial blanking is the nominal setting but Smart Blanking is available.*

- If the Fixed Sensing Method is selected, Fixed Blanking is the nominal setting and Smart Blanking is not available for any chamber.
- When a change to the Sensing Method occurs, blanking periods will automatically revert to the nominal value associated with that Sensing Method unless the blanking period was previously reprogrammed. If the blanking period was previously reprogrammed for a Sensing Method, the period will revert to the last programmed value.

### **RV-Blank after A-Pace**

RV-Blank after A-Pace is a cross-chamber blanking period designed to promote the appropriate sensing of RV events and prevent oversensing of cross-chamber events following an atrial pace.

The pulse generator will not respond to RV events for the duration selected following an atrial pace.

**NOTE:** *Smart Blanking is not available for the RV-Blank after A-Pace parameter.*

When adjusting Blanking, consider the following:

- To promote continuous pacing for pacemaker-dependent patients, it may be preferable to lessen the potential for ventricular oversensing of atrial paced artifacts by programming a longer blanking period. However, programming a longer blanking period may increase the likelihood of undersensing R-waves (e.g., PVCs, should they occur within the RV-Blank after A-Pace cross-chamber blanking period).
- For patients with a high percentage of atrial pacing and frequent PVCs who are not pacemaker-dependent, it may be preferable to shorten the blanking period to lessen the potential for undersensing a PVC (should it occur in the cross-chamber blanking period following an atrial paced event). However, a shorter blanking period may increase the likelihood for ventricular oversensing of an atrial paced event.

Certain programmed combinations of dual-chamber pacing parameters may interfere with ventricular tachy detection. For example, when dual-chamber pacing occurs, RV undersensing due to the refractory period caused by an atrial pace (RV-Blank after A-Pace) could occur. In certain usage scenarios, if a pattern of atrial pacing and VT beats is detected, the Brady Tachy Response (BTR) feature will automatically adjust the AV Delay to facilitate confirmation of a suspected VT. If no VT is present, the AV Delay is returned to the programmed value. For programming scenarios where the automatic AV Delay adjustment may occur, a specific Parameter Interaction Attention will not be displayed. For discussion of details, please contact Boston Scientific using the information on the back cover.

### **A-Blank after V-Pace**

A-Blank after V-Pace is a cross-chamber blanking period designed to promote the appropriate sensing of P-waves and prevent oversensing of cross-chamber events following a ventricular pace.

Boston Scientific Confidential. Unauthorized use is prohibited.

**LIT APPROVAL - INGENIO 1-2 MRI REF GUIDE US**

A-Blank after V-Pace may be programmed to a Fixed or Smart (available with the AGC Sensing Method) value.

If the value is programmed to Smart, the pulse generator automatically raises the AGC threshold for sensing at the expiration of the Smart Blanking period in order to aid rejection of cross-chamber ventricular events. This promotes sensing of P-waves that may have otherwise fallen in the cross-chamber blanking period. Smart Blanking does not change the programmed Sensitivity settings.

**A-Blank after RV-Sense**

A-Blank after RV-Sense is a cross-chamber blanking period designed to promote appropriate sensing of P-waves and prevent oversensing of cross-chamber events following an RV-sensed event.

A-Blank after RV-Sense may be programmed to a Fixed or Smart (available with the AGC Sensing Method) value.

If the value is programmed to Smart, the pulse generator automatically raises the AGC threshold for sensing at the expiration of the Smart Blanking period in order to aid rejection of cross-chamber RV events. This promotes sensing of P-waves that may have otherwise fallen in the cross-chamber blanking period. Smart Blanking does not change the programmed Sensitivity settings.

Refer to the following illustrations:

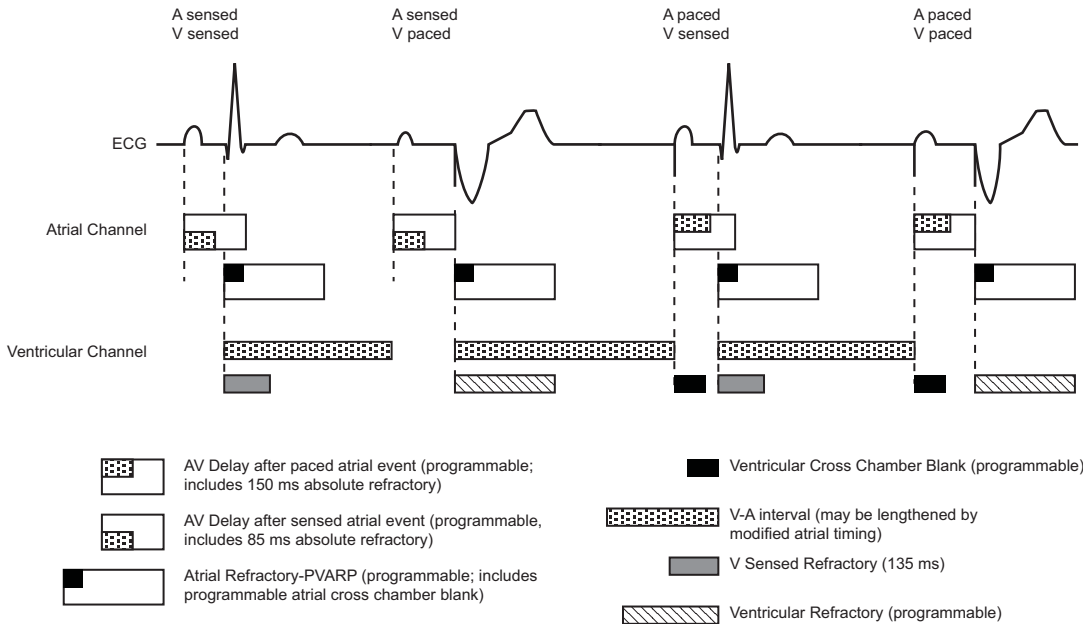

Figure 2-40. Refractory periods, dual-chamber pacing modes



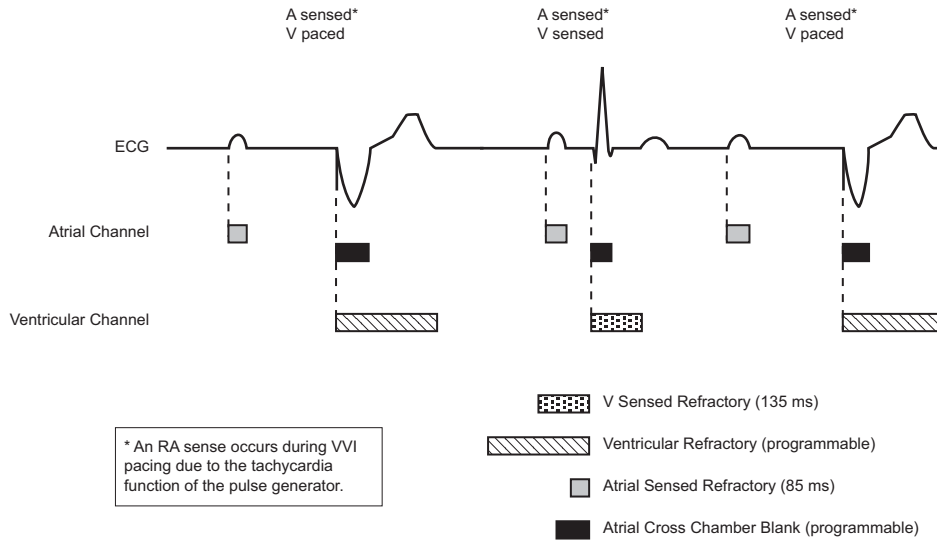

Figure 2-41. Refractory periods, VVI pacing mode

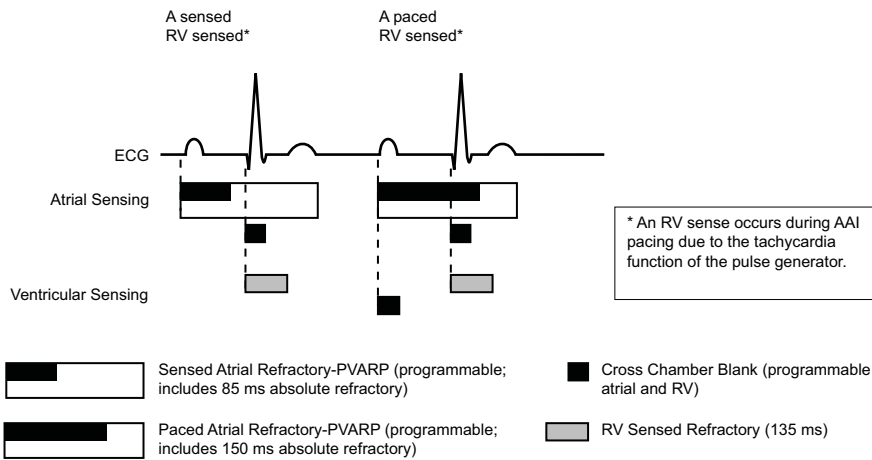

Figure 2-42. Refractory periods, AAI pacing mode; DR

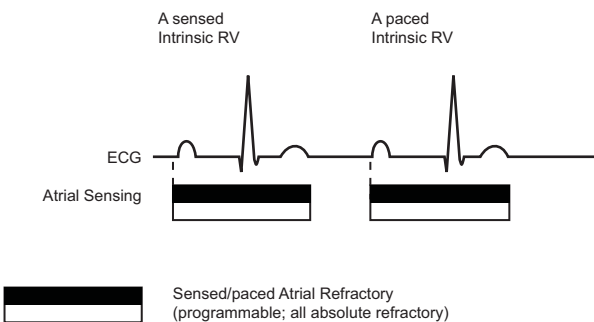

Figure 2-43. Refractory periods, AAI pacing mode; SR

## NOISE RESPONSE

This feature is available in ACCOLADE, PROPONENT, ESSENTIO, ALTRUA 2, FORMIO, VITALIO, INGENIO, and ADVANTIO devices.

Boston Scientific Confidential. Unauthorized use is prohibited.

LIT APPROVAL - INGENIO 1-2 MRI REF GUIDE US

Noise windows and blanking periods are designed to prevent pacing inhibition due to cross-chamber oversensing.

Noise Response allows the clinician to choose whether to pace or inhibit pacing in the presence of noise.

A retriggerable, 40-ms noise window exists within each refractory and fixed (non-smart) cross-chamber blanking period. The window is initiated by either a sensed or paced event. Both the noise window and the refractory period must be completed for each cardiac cycle in one chamber before the next event restarts the timing in the same chamber. Recurrent noise activity may cause the noise window to restart, extending the noise window and possibly the effective refractory period or blanking period.

The Noise Response parameter can be programmed to Inhibit Pacing or an asynchronous mode. The available asynchronous mode will automatically correspond to the permanent Brady Mode (i.e., VVI permanent mode will have VOO noise response). If Noise Response is programmed to an asynchronous mode and the noise persists so that the noise window is extended longer than the programmed pacing interval, the pulse generator paces asynchronously at the programmed pacing rate until the noise ceases. If Noise Response is programmed to Inhibit Pacing and persistent noise occurs, the pulse generator will not pace in the noisy chamber until after the noise ceases. The Inhibit Pacing mode is intended for patients whose arrhythmias may be triggered by asynchronous pacing.

Refer to the following illustrations.

RA refractory periods may be programmable or nonprogrammable depending on the mode (single- vs dual-chamber). Refer to Figure 2-45 on page 2-70.

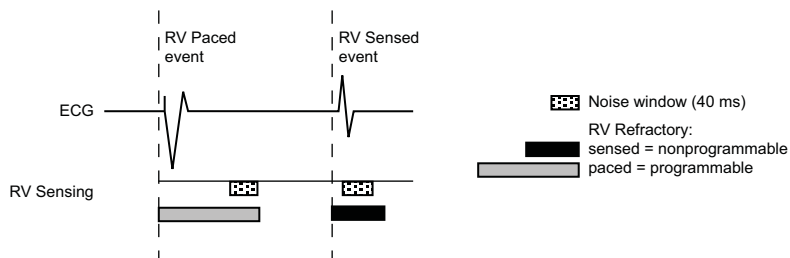

Figure 2-44. Refractory periods and noise windows, RV

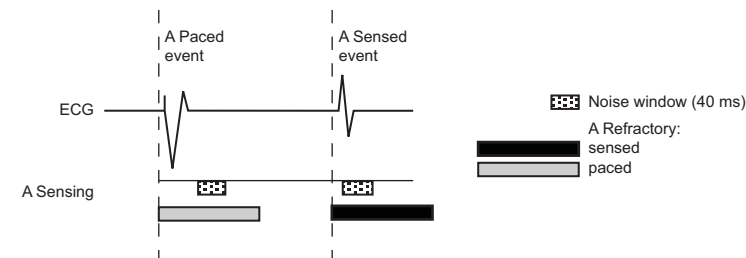

Figure 2-45. Refractory periods and noise windows, RA

In addition, a nonprogrammable Dynamic Noise Algorithm is active in rate channels where AGC Sensing is used.

The Dynamic Noise Algorithm uses a separate noise channel to continuously measure the baseline signal and adjust the sensing floor to avoid noise detection. This algorithm is intended to help prevent oversensing of myopotential signals and the problems associated with oversensing.

Boston Scientific Confidential. Unauthorized use is prohibited.

The following noise event markers are generated:

### Single-Chamber

Depending on which mode is selected:

- The marker [AS] or [VS] occurs when the noise window is initially triggered following an A pace or a V pace, respectively
- If retriggered for 340 ms, the marker AN or VN occurs
- With continuous retriggers, the marker AN or VN occurs frequently
- If asynchronous pacing occurs due to continuous noise, the marker AP-Ns or VP-Ns will occur

### Dual-Chamber

- Depending on the chamber where noise is occurring, the marker [AS] or [VS] occurs when the noise window is initially triggered following a pace
- If retriggered for 340 ms, the marker AN or VN occurs
- With continuous retriggers, the marker AN or VN occurs frequently
- If asynchronous pacing occurs due to continuous noise, the markers AP-Ns, VP-Ns will occur

**NOTE:** *In pacemaker-dependent patients, use care when considering setting Noise Response to Inhibit Pacing as pacing will not occur in the presence of noise.*

### Noise Response example

Cross-chamber sensing that occurs early in the AV Delay may be detected by the RV sense amplifiers during the fixed blanking period, but is not responded to except to extend the noise rejection interval. The 40 ms noise rejection interval continues to retrigger until the noise is no longer detected, up to the length of the AV Delay. If noise continues throughout the duration of the AV Delay, the device will deliver a pacing pulse when the AV Delay timer expires, preventing ventricular inhibition due to noise. If a ventricular pacing spike is delivered under conditions of continuous noise, a VP-Ns marker notation appears on the intracardiac electrogram (Figure 2-46 on page 2-72).

If noise ceases prior to the expiration of the AV Delay, the device can detect an intrinsic beat that occurs at any time beyond the 40 ms retriggerable noise interval and initiate a new cardiac cycle.

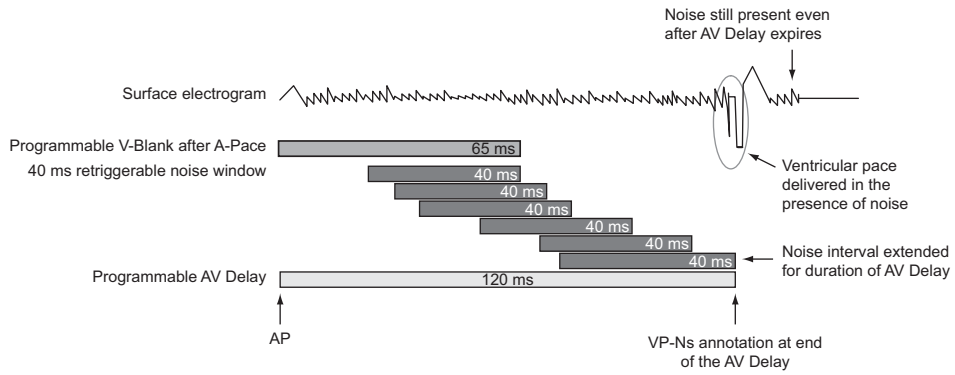

Figure 2-46. Noise Response (fixed blanking)

## SYSTEM DIAGNOSTICS

---

### CHAPTER 3

This chapter contains the following topics:

- "Summary Dialog" on page 3-2
- "Battery Status" on page 3-2
- "Leads Status" on page 3-6
- "Post-Operative System Test (POST)" on page 3-11
- "Lead Tests" on page 3-11

## SUMMARY DIALOG

Upon interrogation, a Summary dialog is displayed. It includes Leads and POST information, Battery status indications, approximate time to explant, and an Events notification for any episodes since the last reset. In addition, a magnet notification will appear if the pulse generator detects the presence of a magnet.

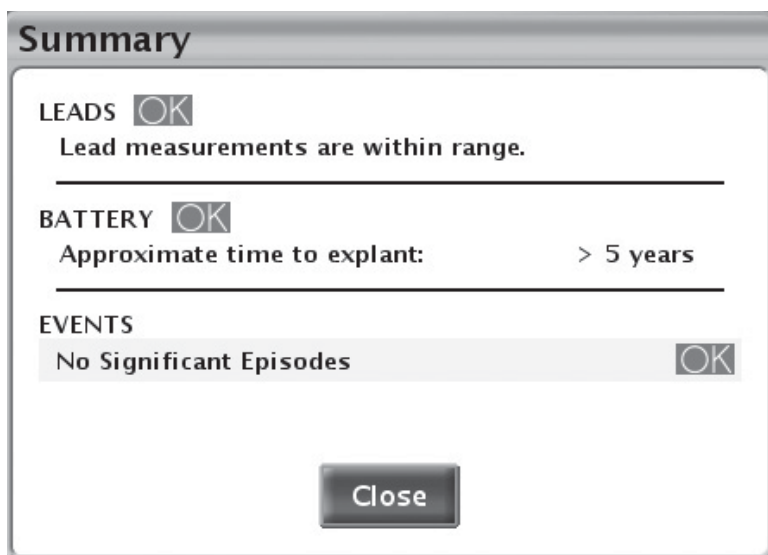

Figure 3-1. Summary dialog

Potential status symbols include OK, Attention, or Warning ("Use of Color" on page 1-7). Potential messages are described in the following sections:

- Leads—"Leads Status" on page 3-6
- Battery—"Battery Status" on page 3-2
- Events—"Therapy History" on page 4-2

Once the Close button is selected, the Warning or Attention symbols for Leads and Battery will not appear on subsequent interrogations until additional events triggering an alert condition occur. Events will continue to appear until any history counter Reset button is selected.

## BATTERY STATUS

The pulse generator automatically monitors battery capacity and performance. Battery status information is provided via several screens:

- Summary dialog—displays a basic status message about remaining battery capacity ("Summary Dialog" on page 3-2).
- Summary tab (on the Main Screen)—displays the same basic status message as the Summary dialog, along with the battery status gauge ("Main Screen" on page 1-2).

- Battery Status Summary screen (accessed from the Summary tab)—displays additional battery status information about remaining battery capacity and current Magnet Rate ("Battery Status Summary Screen" on page 3-3).
- Battery Detail screen (accessed from the Battery Status Summary screen)—provides detailed information about battery use, capacity, and performance ("Battery Detail Summary Screen" on page 3-5).

### Battery Status Summary Screen

The Battery Status Summary screen provides the following key information about battery capacity and performance.

#### Time Remaining

This section of the screen displays the following items:

- Battery status gauge—displays a visual indication of the time remaining to explant.

**NOTE:** *Battery status can be assessed using a manually applied external magnet stronger than 70 gauss. The pacing rate activated by magnet application provides an indication of battery status on the Battery Status Summary screen. For details, refer to "Magnet Rate" below.*

- Approximate time to explant—displays the estimate of calendar time remaining until the pulse generator reaches the Explant status.

This estimate is calculated using battery capacity consumed, charge remaining, and power consumption at current programmed settings.

When insufficient usage history is available, Approximate time to explant may change between interrogation sessions. This fluctuation is normal, and occurs as the pulse generator collects new data and can calculate a more stable prediction. Approximate time to explant will be more stable after several weeks of usage. Causes of fluctuation may include the following:

- If certain brady features that affect pacing output are reprogrammed, the Approximate time to explant will be forecasted based on the expected changes in power consumption from the reprogrammed features. The next time the pulse generator is interrogated, the PRM will resume displaying Approximate time to explant based on recent usage history. As new data is collected, Approximate time to explant will likely stabilize near the initial forecast.
- For several days post-implant, the PRM will display a static Approximate time to explant based on model-dependent data. Once enough usage data has been collected, device-specific predictions will be calculated and displayed.

### Magnet Rate

When the Magnet Response is programmed to Pace Async, magnet application converts the pulse generator Brady Mode to an asynchronous mode with a fixed pacing rate and magnet AV Delay of 100 ms.

The asynchronous pacing rate will reflect the current battery status and is displayed on the Battery Status Summary screen:

More than One Year Remaining	100 ppm
One Year or Less Remaining	90 ppm
Explant	85 ppm

Additional information about Pace Async and the Magnet Feature is available ("Magnet Feature" on page 4-19).

**Battery Detail icon**

When selected, this icon displays the Battery Detail Summary screen ("Battery Detail Summary Screen" on page 3-5).

**Battery Status Indicators**

The following battery status indicators appear in the battery status gauge. The indicated Approximate time to explant is calculated based on the pulse generator’s current programmed parameters.

One Year Remaining—approximately one year of full pulse generator function remains (Approximate time to explant is one year).

Explant—The battery is nearing depletion, and pulse generator replacement must be scheduled. Once Explant status is reached, there is sufficient battery capacity to pace 100% under existing conditions for three months. When Explant status is reached, 1.5 hours of ZIP telemetry remain. Consider using wanded telemetry.

**NOTE:** *When the 1.5 hours of telemetry are exhausted, a LATITUDE alert is generated.*

Battery Capacity Depleted—pulse generator functionality is limited, and therapies can no longer be guaranteed. This status is reached three months after Explant status is reached. The patient should be scheduled for immediate device replacement. Upon interrogation, the Limited Device Functionality screen is displayed (all other screens are disabled). This screen provides battery status information and access to remaining device functionality. ZIP telemetry is no longer available.

**NOTE:** *A LATITUDE alert is generated, after which LATITUDE NXT is no longer available.*

When the device reaches Battery Capacity Depleted status, functionality is limited to the following:

- Brady Mode will be changed as described below:

<b>Brady Mode prior to Battery Capacity Depleted Indicator</b>	<b>Brady Mode after Battery Capacity Depleted Indicator</b>
DDD(R), DDI(R), VDD(R), VVI(R)	VVI
AAI(R)	AAI
Off	Off
DOO, VOO	VOO
AOO	AOO

- Brady Mode can be programmed to Off; no other parameters are programmable
- Wanded telemetry only (RF telemetry is disabled)

Boston Scientific Confidential. Unauthorized use is prohibited.

LIT APPROVAL - INGENIO 1-2 MRI REF GUIDE US



- An LRL of 50 ppm

At Battery Capacity Depleted status, the following features are disabled:

- Daily Measurement trends
- Brady enhancements (e.g., rate response, Rate Smoothing)
- PaceSafe RV Automatic Capture (the output is fixed at 2X the last measurement but not more than 5 V or less than 3.5 V)
- PaceSafe RA Automatic Threshold (the output is fixed at the current output value)
- Lead Safety Switch (the lead configuration remains as it was programmed when the device reached Battery Capacity Depleted status)
- Episode storage
- Diagnostic and EP Tests
- Real-time EGMs
- MV sensor
- Accelerometer

If the device reaches a point where insufficient battery capacity is available for continued operation, the device will revert to Storage Mode. In Storage Mode, no functionality is available.

**WARNING:** MRI scanning after Explant status has been reached may lead to premature battery depletion, a shortened device replacement window, or sudden loss of pacing. After performing an MRI scan on a device that has reached Explant status, verify pulse generator function and schedule device replacement.

**NOTE:** *The device uses the programmed parameters and recent usage history to predict Approximate time to explant. Greater than normal battery usage may result in the subsequent day's Approximate time to explant to appear less than expected.*

### Battery Detail Summary Screen

The Battery Detail summary screen provides the following information about pulse generator battery status (Figure 3-2 on page 3-6):

- Charge Remaining (measured in ampere-hours)—the amount of charge remaining based on the pulse generator's programmed parameters until the battery is depleted.
- Power Consumption (measured in microwatts)—the average daily power being used by the pulse generator, based on currently programmed parameters. Power consumption is included in the calculations that determine Approximate time to explant and the needle position on the battery status gauge.
- Power Consumption Percentage—compares the power consumption at the pulse generator's currently programmed parameters with the power consumption of the standard parameters used to quote device longevity.

If any of the following parameters (which affect pacing output) are reprogrammed, the Power Consumption and Power Consumption Percentage values are adjusted accordingly:

- Amplitude
- Pulse Width

Boston Scientific Confidential. Unauthorized use is prohibited.

LIT APPROVAL - INGENIO 1-2 MRI REF GUIDE US

- Brady Mode
- LRL
- MSR
- PaceSafe

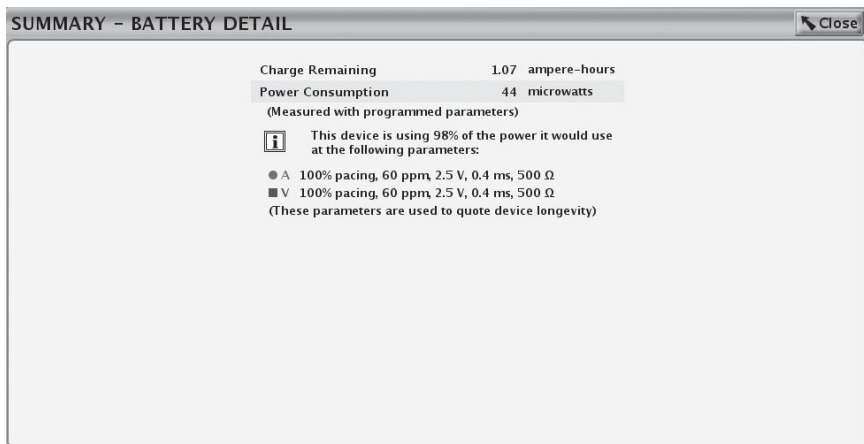

Figure 3-2. Battery Detail summary screen

## LEADS STATUS

### Daily Measurements

The device performs the following measurements every 21 hours and reports them daily:

- Daily Intrinsic Amplitude measurement: the device will automatically attempt to measure the intrinsic P- and R- wave amplitudes for each cardiac chamber in which the Daily Intrinsic Amplitude measurement is enabled regardless of the pacing mode. This measurement will not affect normal pacing. The device will monitor up to 255 cardiac cycles to find a sensed signal to obtain a successful measurement.

- Daily lead (Pace Impedance) measurement:
  - Pace lead(s)—the device will automatically attempt to measure the pace lead impedance for each chamber in which the Daily Pace Impedance test is enabled, regardless of the pacing mode. To conduct the Lead Impedance Test the device utilizes a sub-pacing threshold signal that will not interfere with normal pacing or sensing.
  - For ACCOLADE, PROPONENT, ESSENTIO, and ALTRUA 2 devices, the High Impedance Limit is nominally set to 2000  $\Omega$ , and is programmable between 2000 and 3000  $\Omega$  in 250  $\Omega$  increments. The Low Impedance Limit is nominally set to 200  $\Omega$ , and is programmable between 200 and 500  $\Omega$  in 50  $\Omega$  increments.

For FORMIO, VITALIO, INGENIO, and ADVANTIO devices, the High Impedance Limit is fixed at 2000  $\Omega$ . The Low Impedance Limit is nominally set to 200  $\Omega$ , and is programmable between 200 and 500  $\Omega$  in 50  $\Omega$  increments.

Consider the following factors when choosing a value for the impedance limits:

- For chronic leads, historical impedance measurements for the lead, as well as other electrical performance indicators such as stability over time
- For newly implanted leads, the starting measured impedance value

**NOTE:** Depending on lead maturation effects, during follow-up testing the physician may choose to reprogram the Impedance Limits.

- Pacing dependence of the patient
- Recommended impedance range for the lead(s) being used, if available

- PaceSafe daily threshold measurements—when PaceSafe is programmed to Auto or Daily Trend, the device will automatically attempt to measure the pacing threshold in the chamber for which PaceSafe is programmed. To conduct the test, the device adjusts the necessary parameters to facilitate the test.

Basic lead status information is displayed on the Summary screen. Detailed data are displayed in a graphical format on the Leads Status summary screen, which can be accessed by selecting the leads icon on the Summary screen (Figure 3-3 on page 3-9).

Possible leads status messages are as follows (Table 3-1 on page 3-8):

- Lead measurements are within range.
- Check Lead (message will specify which lead)—indicates daily lead measurement(s) are out of range. To determine which measurement is out of range, evaluate the corresponding lead's daily measurement results.

**NOTE:** Out-of-range lead impedance measurements may cause the lead configuration to change to Unipolar ("Lead Safety Switch" on page 2-56).

**NOTE:** A detailed description of PaceSafe-specific messages including notification of lead test failures and lead alerts is available ("PaceSafe" on page 2-13).

Table 3-1. Lead measurement reporting

Lead Measurement	Reported Values	Out-of-Range Limits
A Pace Impedance ( $\Omega$ )	200 to 3000	Low: $\leq$ programmed Atrial Low Impedance Limit High: $\geq$ 2000 (or the programmed Atrial High Impedance Limit)
RV Pace Impedance ( $\Omega$ )	200 to 3000	Low: $\leq$ programmed Right Ventricular Low Impedance Limit High: $\geq$ 2000 (or the programmed Right Ventricular High Impedance Limit)
P-Wave Amplitude (mV)	0.1 to 25.0	Low: $\leq$ 0.5 High: none
R-Wave (RV) Amplitude (mV)	0.1 to 25.0	Low: $\leq$ 3.0 High: none

**NOTE:** For single-chamber devices, the Amplitude and Impedance values reported and out of range limits applied correspond to the selected lead position and mode.

The Leads Status summary screen provides daily measurement details for applicable leads (Figure 3-3 on page 3-9):

- The graph shows daily measurements from the past 52 weeks.
- Use the tabs across the top of the screen to view data for each lead. Select the Setup tab to enable or disable specific daily lead measurements or to set the Impedance Limit values.

**NOTE:** Disabling daily lead impedance measurements in a given chamber also disables the Lead Safety Switch feature in that chamber.

- Each data point represents the daily measurement or POST results for a given day. To view specific results for a day, move the horizontal slider over the corresponding data point or gap.
- An out-of-range measurement will plot a point at the corresponding maximum or minimum value.
- A gap will be generated if the device is unable to obtain a valid measurement for that day.
- The most recent daily measurements or POST results are displayed at the bottom of the screen.

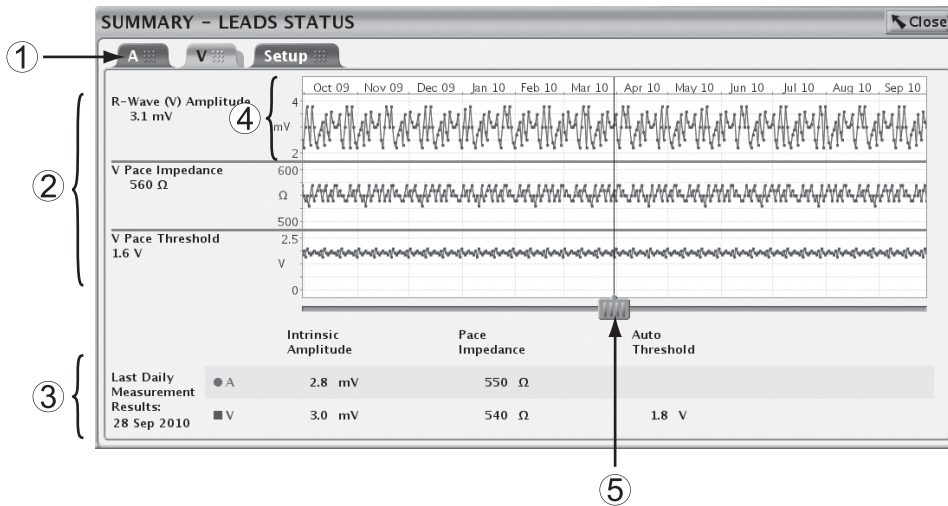

[1] Use tabs to select the appropriate lead [2] Results for the selected day [3] Results for most recent day [4] Y-axis adjusts based on measured results [5] Use horizontal slider to view data for a specific day

Figure 3-3. Leads Status summary screen

If the device is unable to obtain one or more daily measurements at the scheduled time, up to three re-attempts will be performed at one-hour intervals. Re-attempts do not change the timing of daily measurements. The next day's measurement will be scheduled 21 hours from the initial attempt.

If a valid measure is not recorded after the initial attempt plus three re-attempts, or is not recorded at the end of a 24-hour time block, the measurement will be reported as Invalid Data or No data collected (N/R).

When more than one measurement occurs in one day, only one will be reported. For Amplitude and Impedance, if one of the measurements is valid and one invalid, the invalid measurement will be reported. If both measurements are valid, the most recent value will be reported. For Threshold, if one measurement is valid and one invalid, the valid measurement will be reported. If both measurements are valid, the highest value will be reported.

If the Summary screen indicates that a lead should be checked and the Intrinsic Amplitude and Impedance graphs do not show any out-of-range values or gaps, the test that resulted in the out-of-range value occurred within the current 24 hours and has not yet been saved with the daily measurements.

Table 3-2. Intrinsic Amplitude: Daily Measurement Conditions, Programmer Display, and Graphical Representation

Condition	Programmer Display	Graphical Representation
In-range amplitude measurement	Measurement value	Plotted point
Electrode configuration is programmed to Off/None	No data collected	Gap
All events during the test period are paced	Paced	Gap
Noise detected during the test period	Noise	Gap
Sensed events defined as a PVC	PVC	Gap
Sensed events defined as a PAC	PAC	Gap

**Table 3-2. Intrinsic Amplitude: Daily Measurement Conditions, Programmer Display, and Graphical Representation** (continued)

Condition	Programmer Display	Graphical Representation
Out-of-range amplitude measurements (mV)	0.1, 0.2, ..., 0.5 (RA lead) with attention icon 0.1, 0.2, ..., 3.0 (ventricular lead) with attention icon	Plotted point
	< 0.1 with attention icon	Plotted point at corresponding minimum
	> 25 with attention icon	Plotted point at corresponding maximum <sup>a</sup>

a. When the value measured is > 25 mV, an attention symbol is displayed on the graph even though no alert is generated on the summary screens.

**Table 3-3. Lead Impedance: Daily Measurement Conditions, Programmer Display, and Graphical Representation**

Condition	Programmer Display	Graphical Representation
In-range amplitude measurement	Measurement value	Plotted point
Electrode Configuration is programmed Off/None	Invalid Data	Gap
Noise detected during the test period	Noise	Gap
Out-of-range impedance measurements (pace leads) (Ω)	Measured value greater than or equal to the Pace High Impedance Limit with attention icon Measured value less than or equal to the Pace Low Impedance Limit with attention icon	Plotted point
	> Maximum Pace High Impedance Limit with attention icon < Minimum Pace Low Impedance Limit with attention icon	Plotted point at corresponding minimum or maximum <sup>a</sup>

a. Selecting these points will not display the numerical value, but will indicate that the value is above the upper range limit or below the lower range limit, as appropriate.

**Table 3-4. PaceSafe Automatic Threshold: Daily Measurement Conditions, Programmer Display, and Graphical Representation**

Condition	Programmer Display	Graphical Representation
Feature is not enabled	No data collected	Gap
Test failures or out of range measurements	Various	Gap

**NOTE:** See a detailed list of failure codes for PaceSafe Threshold tests ("PaceSafe" on page 2-13).

Under the following conditions, Intrinsic Amplitude and Lead Impedance measurements will not be attempted. The programmer display will indicate No data collected or Invalid Data, and there will be a gap in the graphical representation:

- Telemetry is active
- Device battery capacity is depleted
- LATITUDE interrogation is in progress
- Pulse generator is in Electrocautery Protection Mode
- Pulse generator is in MRI Protection Mode
- Magnet is placed on the pulse generator (when Magnet Response set to Pace Async)

See a detailed description of conditions under which PaceSafe measurements will not be attempted ("PaceSafe" on page 2-13).

## POST-OPERATIVE SYSTEM TEST (POST)

This feature is available in ACCOLADE, PROPONENT, and ESSENTIO devices.

The POST feature provides an automatic device/lead check at a pre-determined time post-implant. This helps document proper system functionality without requiring manual system testing, which helps facilitate same-day discharge. The clinician can select the amount of time after lead attachment when automatic lead test results are desired. Any adjustments to the nominal test results time must be programmed prior to lead attachment.

If enabled, automatic Intrinsic Amplitude, Impedance, and Pace Threshold testing will be attempted one hour prior to the desired test results time. Upon interrogation, status of the testing (scheduled to run, in-progress, complete) will be provided on the Summary dialog and Summary screen for the first 48 hours following lead attachment. Test results can be printed on Quick Notes and Follow-Up Reports.

**NOTE:** *Pacing parameters may be temporarily adjusted to help ensure a valid measurement is obtained.*

If the device is unable to obtain one or more valid measurements on the initial attempt, re-attempts will be performed to help facilitate a measurement. Testing may complete up to one hour after the test results time if re-attempts are required. If a valid measurement is not obtained, and/or if automatic daily measurements occur prior to printing the report, the daily measurement result may be recorded ("Leads Status" on page 3-6).

## LEAD TESTS

The following lead tests are available (Figure 3-4 on page 3-11):

- Pace Impedance
- Intrinsic Amplitude
- Pace Threshold

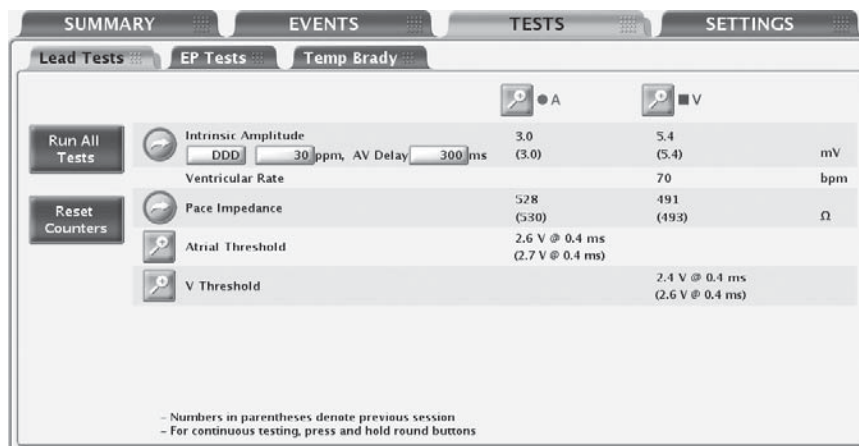

Figure 3-4. Lead Tests screen

Lead Tests can be accessed by using the following steps:

1. From the main screen, select the Tests tab.

Boston Scientific Confidential. Unauthorized use is prohibited.

LIT APPROVAL - INGENIO 1-2 MRI REF GUIDE US

2. From the Tests screen, select the Lead Tests tab.

All lead tests may be performed following three different processes:

- Via the Lead Tests screen—allows you to perform the same lead tests across all chambers
- By selecting the desired chamber button—allows you to perform all tests on the same lead
- By selecting the Run All Tests button—automatically performs Intrinsic Amplitude and Lead Impedance tests and allows you to perform Pace Threshold tests

## Intrinsic Amplitude Test

The Intrinsic Amplitude Test measures the intrinsic P- and R-wave amplitudes for the respective chambers.

An Intrinsic Amplitude Test can be performed from the Lead Tests screen by completing the following steps:

1. You may change the following preselected values as necessary to elicit intrinsic activity in the chamber(s) being tested:
  - Programmed Normal Brady Mode
  - LRL at 30 ppm
  - AV Delay at 300 ms
2. Select the Intrinsic Amplitude button. During the test, a window will display the test's progress. Selecting and holding the Intrinsic Amplitude Button will cause measurements to be repeated for up to 10 seconds or until the button is released. When the window closes, the same test can be performed again by selecting the Intrinsic Amplitude button. To cancel the test, select the Cancel button or press the DIVERT THERAPY key on the PRM.
3. When the test is complete, the Intrinsic Amplitude measurement will be displayed as the Current measurement (not in parentheses). If the test is repeated during the same session, the Current measurement will be updated with the new result. Note that the Previous Session measurement (displayed in parentheses) is from the most recent past session during which this test was performed.

**NOTE:** *The test results from the last measurement are stored in pulse generator memory, retrieved during the initial interrogation, and displayed on the Lead Tests screen. The measurements are also provided on the Quick Notes report.*

## Lead Impedance Test

A Lead Impedance Test can be performed and used as a relative measure of lead integrity over time.

If the lead integrity is in question, standard lead troubleshooting tests should be used to assess the lead system integrity.

Troubleshooting tests include, but are not limited to, the following:

- Electrogram analysis with pocket manipulation and/or isometrics
- X-ray or fluoroscopic image review

Boston Scientific Confidential. Unauthorized use is prohibited.

LIT APPROVAL - INGENIO 1-2 MRI REF GUIDE US



- Invasive visual inspection

A test result of NOISE is reported if a valid measurement could not be obtained (likely due to EMI).

Pace lead impedance tests can be performed from the Lead Tests screen by completing the following steps:

1. Select the desired lead impedance test button. Selecting and holding a button will cause measurements to be repeated for up to 10 seconds or until the button is released.
2. During the test, a window will display the test progress. When the window closes, the same test can be performed by once again selecting the desired lead impedance test button. To cancel the test, select the Cancel button or press the DIVERT THERAPY key on the PRM.
3. When the test is complete, the impedance measurement will be displayed as the Current measurement (not in parentheses). If the test is repeated during the same session, the Current measurement will be updated with the new result. Note that the Previous Session measurement (displayed in parentheses) is from the most recent past session during which this test was performed.
4. If the test results in NOISE, consider the following mitigation options:
  - Repeat the test
  - Switch telemetry modes
  - Remove other sources of electromagnetic interference

**NOTE:** The test results from the last measurement are stored in pulse generator memory, retrieved during the initial interrogation, and displayed on the Lead Tests screen. The measurements are also provided on the Quick Notes report.

## Pace Threshold Test

The Pace Threshold Test determines the minimum output needed for capture in a specific chamber.

The ventricular and atrial pace amplitude threshold tests can be performed manually or automatically. When PaceSafe is programmed to Auto, the results of the commanded automatic amplitude tests are used to adjust the PaceSafe output levels.

Ventricular and atrial pulse width threshold tests are performed manually by selecting the Pulse Width option on the Pace Threshold details screen.

### Manual Pace Threshold Test

The minimum 2X voltage or 3X pulse width safety margin is recommended for each chamber based on the capture thresholds, which should provide an adequate safety margin and help preserve battery longevity. The test begins at a specified starting value and steps that value down (Amplitude or Pulse Width) as the test progresses. The PRM beeps with each decrement. The values used during the threshold test are programmable. The parameters are only in effect during the test.

**NOTE:** The starting values for Amplitude and Pulse Width values are automatically calculated. The device retrieves the stored results for the previous pace threshold measurement (for the parameter being tested) and sets the parameter at three steps above the previous threshold measurement. The LRL is preselected at 90 ppm. For DDD mode, the LRL is further limited to 10 ppm below the MTR.

**NOTE:** If DDD mode is chosen, selecting either the atrial or ventricular test will cause the pacing output to decrease only in the chamber selected.

Once the test is started, the device operates with the specified brady parameters. Using the programmed number of cycles per step, the device then decrements (steps down) the selected test type parameter (Amplitude or Pulse Width) until the test is complete. Real-time electrograms and annotated event markers, which include the values being tested, continue to be available during threshold testing. The display will automatically adjust to reflect the chamber being tested.

During the threshold test, the programmer displays the test parameters in a window while the test is in progress. To pause the test or perform a manual adjustment, select the Hold button on the window. Select the + or – button to manually increase or decrease the value being tested. To continue the test, select the Continue button.

The threshold test is complete and all parameters are returned to the normal programmed values when any of the following occur:

- The test is terminated via a command from the PRM (e.g., pressing the End Test button or DIVERT THERAPY key).
- The lowest available setting for Amplitude or Pulse Width is reached and the programmed number of cycles has completed.
- Telemetry communication is interrupted.

A pace threshold test can be performed from the Lead Tests screen using the following steps:

1. Select the desired chamber to be tested.
2. Select the Pace Threshold details button.
3. Select the test type.
4. Change the following parameter values as desired to elicit pacing in the chamber(s) being tested:
  - Mode
  - LRL
  - Paced AV Delay
  - Pacing Lead Configuration
  - Amplitude
  - Pulse Width
  - Cycles per Step

For DDD mode, the Normal Brady MTR is used.

5. Watch the ECG display and stop the test by selecting the End Test button or pressing the DIVERT THERAPY key when loss of capture is observed. If the test continues until the programmed

Boston Scientific Confidential. Unauthorized use is prohibited.

LIT APPROVAL - INGENIO 1-2 MRI REF GUIDE US

number of cycles at the lowest setting have occurred, the test is automatically terminated. The final threshold test value will be displayed (the value is one step above the value when the test was terminated). A 10 second trace (prior to loss of capture) is automatically stored and can be displayed and analyzed by selecting the Snapshot tab ("Snapshot" on page 4-8).

**NOTE:** *The threshold test result can be edited by selecting the Edit Today's Test button on the Threshold Test screen.*

6. When the test is complete, the threshold measurement will be displayed as the Current measurement (not in parentheses). If the test is repeated during the same session, the Current measurement will be updated with the new result. Note that the Previous Session measurement (displayed in parentheses) is from the most recent past session during which this test was performed.
7. To perform another test, make changes to the test parameter values if desired, then begin again. Results of the new test will be displayed.

**NOTE:** *The test results from the most recent measurement are stored in pulse generator memory, retrieved during initial interrogation, and displayed on the Lead Tests screen and on the Leads Status screen. The measurements are also provided on the Quick Notes report.*

### **Commanded Automatic Pace Threshold Test**

This feature is available in ACCOLADE, PROPONENT, ESSENTIO, ALTRUA 2, FORMIO, VITALIO, INGENIO, and ADVANTIO devices.

Commanded automatic threshold tests differ from the manual tests in the following ways:

- Commanded automatic threshold tests are available for Amplitude, but not Pulse Width.
- The following parameters are fixed (vs. programmable in manual tests):
  - Paced AV Delay
  - Pulse Width
  - Cycles per step
  - Pacing Lead Configuration (RAAT)

**NOTE:** *Change the programmable parameters as desired to elicit pacing in the chamber being tested.*

- Additional event markers are available including loss of capture, fusion, and backup pacing (where backup pacing is available).
- Once started, a commanded automatic threshold test cannot be paused, only cancelled.
- PaceSafe automatically determines when the test is completed and automatically stops the test.
- When complete, the test automatically stops and displays the threshold, which is the last output level that demonstrated consistent capture. A 10 second trace (prior to loss of capture) is automatically stored and can be displayed and analyzed by selecting the Snapshot tab ("Snapshot" on page 4-8).

Boston Scientific Confidential. Unauthorized use is prohibited.

**LIT APPROVAL - INGENIO 1-2 MRI REF GUIDE US**

- Test results cannot be edited.

**NOTE:** *No backup atrial pacing is provided during a commanded automatic right atrial threshold test.*

## PATIENT DIAGNOSTICS AND FOLLOW UP

---

### CHAPTER 4

This chapter contains the following topics:

- "Therapy History" on page 4-2
- "Arrhythmia Logbook" on page 4-2
- "Snapshot" on page 4-8
- "Histograms" on page 4-9
- "Counters" on page 4-10
- "Heart Rate Variability (HRV)" on page 4-11
- "Trends" on page 4-14
- "Post Implant features" on page 4-18

## THERAPY HISTORY

The pulse generator automatically records data that can be helpful when evaluating the patient's condition and the effectiveness of pulse generator programming.

Therapy history data can be reviewed at various levels of detail using the PRM:

- Arrhythmia Logbook—provides detailed information for each detected episode ("Arrhythmia Logbook" on page 4-2)
- Histograms and Counters—displays the total number and percentage of paced and sensed events during a particular recording period ("Histograms" on page 4-9 and "Counters" on page 4-10)
- Heart Rate Variability (HRV)—measures changes in the patient's intrinsic heart rate within a 24-hour collection period ("Heart Rate Variability (HRV)" on page 4-11)
- Trends—provides a graphical view of specific patient, pulse generator, and lead data ("Trends" on page 4-14)

**NOTE:** *The Summary dialog and Summary tab display a prioritized list of events that have occurred since the last reset. This list will only include VT, SVT, Nonsustained, ATR (if it lasted more than 48 hours), and MRI episodes.*

## ARRHYTHMIA LOGBOOK

This feature is available in ACCOLADE, PROPONENT, ESSENTIO, ALTRUA 2, FORMIO, VITALIO, INGENIO, and ADVANTIO devices.

The Arrhythmia Logbook provides access to the following detailed information about episodes of all types (Figure 4-1 on page 4-3):

- The number, date, and time of the event
- The type of event
- A summary of event details
- Duration of the event (when applicable)
- Electrograms with annotated markers
- Intervals

**NOTE:** *The data include information from all active electrodes. The device compresses the history data to store a maximum of 14 minutes of electrogram data (10 minutes with Patient Triggered Monitor enabled). However, the amount of time actually stored may vary based on the data being compressed (e.g., noise on the EGM or an episode of VT).*

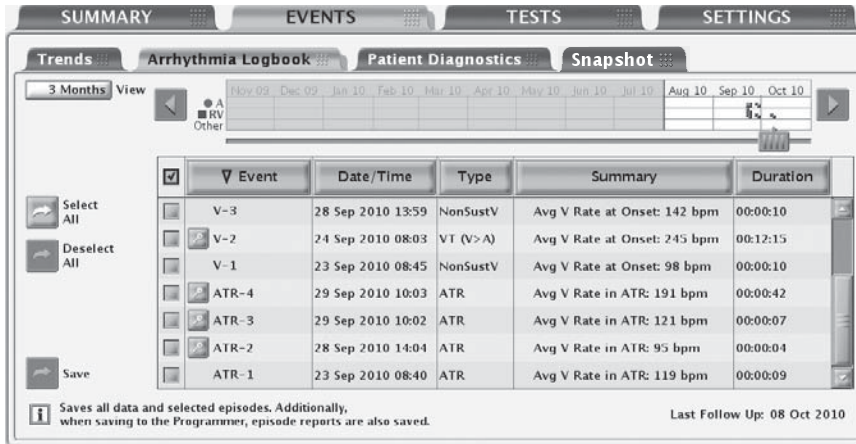

Figure 4-1. Arrhythmia Logbook screen

The priority, maximum number, and minimum number of episodes that the pulse generator stores under normal conditions varies by episode type (Table 4-1 on page 4-3). As long as device memory allocated for episode data is not full, the pulse generator stores up to the maximum number of episodes allowed for each episode type. The minimum number of episodes for each episode type ensures that all episode types are represented by protecting a few low priority episodes from being overwritten by high priority episodes when device memory is full.

Once device memory is full, the pulse generator attempts to prioritize and overwrite stored episodes according to the following rules:

1. If device memory is full, and there are episodes older than 18 months, then the oldest of the lowest priority episodes from these episode types will be deleted (regardless if the minimum number of episodes are stored) (ACCOLADE, PROPONENT, ESSENTIO, and ALTRUA 2 devices).
  2. If device memory is full, and there are episode types that have more than the minimum number of episodes stored, then the oldest of the lowest priority episodes from these episode types will be deleted. In this case, the low priority episodes are not deleted if their number of stored episodes is less than the minimum number.
  3. If device memory is full, and there are no episode types that have more than the minimum number of episodes stored, then the oldest of the lowest priority episodes of all episode types will be deleted.
  4. If the maximum number of episodes has been reached within an episode type, the oldest episode of that type will be deleted.
- An episode in progress has the highest priority until its type can be determined.

**NOTE:** Once history data is saved, it can be accessed at any time without device interrogation.

Table 4-1. Episode Priority

Episode Type	Priority	Maximum number of stored episodes	Minimum number of stored episodes with detailed reports	Maximum number of stored episodes with detailed reports
VT (V>A) <sup>c</sup>	1	50	5	10
MRI	1	10	1	5

**Table 4-1. Episode Priority** (continued)

Episode Type	Priority	Maximum number of stored episodes	Minimum number of stored episodes with detailed reports	Maximum number of stored episodes with detailed reports
PTM (Patient Triggered Monitor)	1	5	1	1
SVT (V≤A) <sup>a</sup>	2	50	3	5
NonSustV	3	10	1	2
RA Auto <sup>a</sup>	3	1	1	1
RV Auto	3	1	1	1
ATR <sup>a</sup>	4	10	1	3
PMT <sup>a</sup>	4	5	1	3
SBR <sup>a</sup>	4	10	1	3
APM RT <sup>b</sup>	4	1	1	1
RYTHMIQ <sup>a</sup>	4	10	1	3

a. Not available in SR models.

b. Advanced Patient Management real time (APM RT) events are presenting EGMs, captured and stored on the pulse generator during LATITUDE Communicator follow-ups.

c. In an SR device, the episode type is Tachy.

To display Arrhythmia Logbook data, use the following steps:

1. From the Events tab, select Arrhythmia Logbook. If necessary, the pulse generator will be automatically interrogated and current data will be displayed. Saved patient data also can be displayed ("Data Storage" on page 1-18).
2. While retrieving the data, the programmer will display a window indicating the progress of the interrogation. No information will be displayed if you select the Cancel button before all of the stored data are retrieved.
3. Use the slider and View button to control the range of dates for the events you want to display in the table.
4. Select the Details button of an event in the table to display the event details. Event details, available if the details button is present, are useful in evaluating each episode. The Stored Event screen will appear, and you can browse between the following tabs for more information about the event:
  - Events Summary
  - EGM (MRI events do not include EGM data)
  - Intervals (MRI events do not include Interval data)
5. Select a column header button to sort the events by that column. To reverse the order, select the column header again.
6. To save specific events, select the event and choose the Save button. To print specific events, select the event and choose Reports from the toolbar. Choose the Selected Episodes report and select the Print button.



**NOTE:** An “in-progress” episode will not be saved; an episode must be complete before it will be saved by the application.

To view episode details, select the Details button next to the desired episode on the Arrhythmia Logbook screen. The Stored Event screen will appear, and you can browse between the Summary, EGM, and Intervals tabs.

### Events Summary

The Events Summary screen displays additional details about the selected episode corresponding to the Arrhythmia Logbook.

The summary data may include the following:

- Episode number, date, time, type (e.g., VT, SVT, or PTM)
- Average atrial and ventricular rates
- Duration
- Average Ventricular Rate in ATR (ATR events only; may help determine if the patient’s ventricular response to atrial arrhythmias is adequately controlled)
- Atrial rate at PMT start (PMT events only)

### Stored Electrograms with Annotated Markers

The pulse generator can store annotated electrograms sensed from the following channels:

- RV pace/sense lead
- Atrial pace/sense lead
- PaceSafe Evoked Response (ER)

The particular annotated electrograms stored depend upon the episode type. In this section, EGM refers to both electrograms and the associated annotated markers. The EGM storage capacity varies depending on EGM signal condition and heart rate. The total amount of stored EGM data associated with an episode may be limited; EGMs from the middle of the episode may be removed for episodes greater than 4 minutes in duration.

When the memory allocated to EGM storage is full, the device overwrites older EGM data segments in order to store the new EGM data. The EGM is recorded in segments consisting of episode Onset and End EGM Storage. Detailed information for the Onset segment can be viewed when the left caliper is in that section.

Episode Onset refers to the period of time (measured in seconds) of EGM prior to event declaration.

Onset includes the following information:

- Type of event
- Average RA Rate at the start of Event
- Average RV Rate at the start of Event

Boston Scientific Confidential. Unauthorized use is prohibited.

LIT APPROVAL - INGENIO 1-2 MRI REF GUIDE US

- Average V rate during ATR (ATR episodes only)

To view the EGM data, select the Details button of the desired episode on the Arrhythmia Logbook screen.

Use the following steps to view specific details about each episode:

1. Select the EGM tab.

- EGM strips for the appropriate sources are displayed. Each strip includes the EGMs sensed during the episode with the corresponding annotated markers. Blue vertical bars indicate the segment (Onset, End) boundaries.

**NOTE:** For marker definitions, select the Reports button on the PRM and view the Marker Legend Report.

- Use the slider under the upper display window to view different sections of the stored EGM.
- Adjust the trace Speed as needed (10, 25, 50, 100 mm/s). As the Speed is increased, the time/horizontal scale is expanded.

**NOTE:** Adjusting the trace Speed is for on-screen viewing only; the print speed of a stored EGM is set to 25 mm/s.

- Use the electronic caliper (slider bar) to measure the distance/time between signals as well as measure the amplitude of signals.
  - The distance between signals can be measured by moving each caliper to the desired points on the EGM. The time (in milliseconds or seconds) between the two calipers will be displayed.
  - The amplitude of the signal can be measured by moving the left-hand caliper over the peak of the desired signal. The value (in millivolts) of the signal will be displayed on the left side of the EGM. The signal is measured from baseline to peak, either positive or negative. Adjust the trace Speed and/or amplitude scale as needed to help facilitate an amplitude measurement.
- Adjust the amplitude/vertical scale as needed (0.2, 0.5, 1, 2, 5 mm/mV) for each channel using the up/down arrow buttons located on the right side of the trace display. As the gain is increased, the amplitude of the signal is enlarged.

2. Select the Previous Event or Next Event button to display a different event strip.

3. To print the entire episode report, select the Print Event button. To save the entire episode report, select the Save button.

### Intervals

The pulse generator stores event markers and associated time stamps. The PRM derives event intervals from the event markers and time stamps.

To view the episode intervals, use the following steps:

1. From the Stored Event screen, select the Intervals tab. If all of the episode data is not visible in the window, use the scroll bar to view more data.
2. Select the Previous Event or the Next Event button to display a previous or more current episode, one episode at a time.
3. Select the Print Event button to print the entire episode report.
4. Select the Save button to save the entire episode report.

### Ventricular Tachy EGM Storage

The Ventricular Tachy EGM Storage feature will detect and store an Arrhythmia Logbook episode when the patient's intrinsic ventricular rate rises above a programmable threshold. In response to 3 consecutive fast beats, the device will begin storing an episode which will ultimately be classified as: VT ( $V > A$ ), SVT ( $V < A$ ) or a Nonsustained episode. The pulse generator will not provide any tachy therapy (e.g., shocks or ATP).

**NOTE:** *In a single-chamber device, these types of episodes will be classified as Tachy or Nonsustained.*

This feature is available in any Brady Mode. In a dual-chamber device programmed to AAI(R), ventricular sensing for VT detection is used in addition to atrial sensing unless the VT EGM Storage parameter is set to Off.

Tachy EGMs will be stored under the following conditions:

1. To begin storing an episode, 3 consecutive fast beats must occur above the VT Detection Rate. The episode Onset EGM segment will start 5 seconds before the third fast beat, and stop 10 seconds after the third fast beat.
2. The pulse generator then uses a sliding detection window to monitor for 8 out of 10 fast beats. The detection window is the 10 most recently detected ventricular intervals. As a new interval occurs, the window slides to encompass it and the oldest interval is eliminated.
3. Once 8 out of 10 fast beats have been detected, a V-Epsd marker is displayed and a nonprogrammable 10 second Duration begins.

**NOTE:** *For single-chamber devices, an Epsd marker is displayed instead.*

4. A sustained VT episode is declared if 6 out of 10 fast beats are maintained throughout Duration. At the end of Duration, if the rate is still fast, the pulse generator applies the  $V > A$  detection enhancement to determine if the episode is VT ( $V > A$ ) or SVT ( $V \leq A$ ):
  - a. At the end of Duration, the pulse generator calculates averages of the last 10 V–V intervals and the last 10 A–A intervals.

**NOTE:** *If there are fewer than 10 atrial intervals available, the available intervals will be used to determine the average atrial rate. There will always be at least 10 ventricular intervals.*

- b. These averages are compared. If the average ventricular rate is 10 bpm or more faster than the average atrial rate, the episode is declared as VT. Otherwise, it is declared as SVT.

Boston Scientific Confidential. Unauthorized use is prohibited.

LIT APPROVAL - INGENIO 1-2 MRI REF GUIDE US

**NOTE:** The pulse generator will respond to atrial sensing regardless of whether an atrial lead is implanted. If an atrial lead is not implanted, or is not sensing adequately, program the atrial sensing Lead Configuration to Off ("Use of Atrial Information" on page 2-55).

5. A Nonsustained episode is declared if 8 out of 10 fast beats are not detected, or if 6 out of 10 fast beats are not maintained during Duration. The episode will be classified as NonSustV.
6. End of episode is declared under the following conditions:
  - End of Episode timer expires. Once 8 out of 10 fast beats have been detected, a nonprogrammable 10 second End of Episode timer begins whenever fewer than 6 out 10 beats are fast. The timer is only cleared if 8 out of 10 fast beats are once again detected before the timer expires. If the timer expires, End of Episode is declared, and a V-EpsdEnd marker is displayed.

**NOTE:** For single-chamber devices, an EpsdEnd marker is displayed instead.

- If 8 out of 10 fast beats have not been detected, but 10 consecutive slow beats are detected below the VT Detection Rate. No end of episode marker is provided in this scenario.
- EP testing is initiated.
- Ventricular Tachy EGM Storage is reprogrammed.

The episode End EGM segment will start 20 seconds before the end of the episode (may be less than 20 seconds if the Onset and End segments overlap), and stops at the end of the episode.

**NOTE:** For single-chamber pulse generators programmed to AAI(R) mode, all references to ventricular events or intervals described above actually refer to atrial events or intervals, and the resulting stored atrial tachy episodes are labeled as ventricular episodes in the Logbook.

## SNAPSHOT

This feature is available in ACCOLADE, PROPONENT, ESSENTIO, ALTRUA 2, FORMIO, VITALIO, INGENIO, and ADVANTIO devices.

A 12 second trace of the ECG/EGM display can be stored at any time by pressing the Snapshot button from any screen. A trace is also automatically stored following a Pace Threshold Test. After a trace has been stored, it can be displayed and analyzed by selecting the Snapshot tab.

The traces which are currently selected on the ECG/EGM display as well as annotated markers will be captured for up to 10 seconds before and up to 2 seconds after the Snapshot button was selected. If a Snapshot was automatically stored during a Pace Threshold Test, it will be 10 seconds long, ending with the termination of the test.

**NOTE:** The Snapshot length will be reduced if the traces on the ECG/EGM display are changed or the session started within 10 seconds of selecting the Snapshot button.

Up to 6 time-stamped Snapshots will be stored in the PRM memory for the current session only. Once the session has been terminated by exiting the application software or by interrogating a new patient, the data will be lost. If more than 6 Snapshots are stored in one PRM session, the oldest will be overwritten.

Use the following steps to view a stored Snapshot:

1. From the Events tab, select the Snapshot tab.
2. Select the Previous Snapshot or Next Snapshot button to display a different trace.
3. Use the slider under the upper display window to view different sections of the stored Snapshot.
4. Adjust the Speed as needed (10, 25, 50, 100 mm/s). As the Speed is increased, the time/horizontal scale is expanded.

**NOTE:** *Adjusting the Speed is for on-screen viewing only; the print speed of a stored Snapshot is set to 25 mm/s.*

5. Use the electronic caliper (slider bar) to measure the distance/time between signals as well as measure the amplitude of signals.
  - The distance between signals can be measured by moving each caliper to the desired points on the Snapshot. The time (in milliseconds or seconds) between the two calipers will be displayed.
  - The amplitude of the signal can be measured by moving the left-hand caliper over the peak of the desired signal. The value (in millivolts) of the signal will be displayed on the left side of the Snapshot. The signal is measured from baseline to peak, either positive or negative. Adjust the Speed and/or amplitude scale as needed to help facilitate an amplitude measurement.
6. Adjust the amplitude/vertical scale as needed (0.2, 0.5, 1, 2, 5 mm/mV) for each channel using the up/down arrow buttons located on the right side of the trace display. As the gain is increased, the amplitude of the signal is enlarged.
7. To print the Snapshot that is currently being viewed, select the Print button. To save the Snapshot that is currently being viewed, select the Save button. Select Save All Snapshots to save all stored Snapshot traces.

## HISTOGRAMS

This feature is available in ACCOLADE, PROPONENT, ESSENTIO, ALTRUA 2, FORMIO, VITALIO, INGENIO, and ADVANTIO devices.

The Histograms feature retrieves information from the pulse generator and displays the total number and percentage of paced and sensed events for the chamber.

Histograms data can provide the following clinical information:

- The distribution of the patient's heart rates
- How the ratio of paced to sensed beats varies by rate
- How the ventricle responds to paced and sensed atrial beats across rates
- The RV Rate during AT/AF events (ACCOLADE and PROPONENT devices)

Use the following steps to access the Histograms screen:

Boston Scientific Confidential. Unauthorized use is prohibited.

LIT APPROVAL - INGENIO 1-2 MRI REF GUIDE US

1. From the Events screen, select the Patient Diagnostics tab.
2. The initial display shows the paced and sensed data since the last time the counters were reset.
3. Select the Details button to display the data type and time period.
4. Select the Rate Counts button on the Details screen to view rate counts by chamber as well as RV rate counts during AT/AF events (ACCOLADE and PROPONENT devices).

All Histograms can be reset by selecting the Reset button from any Patient Diagnostics Details screen. Histogram data can be saved to the PRM and printed via the Reports tab.

## COUNTERS

This feature is available in ACCOLADE, PROPONENT, ESSENTIO, ALTRUA 2, FORMIO, VITALIO, INGENIO, and ADVANTIO devices.

The following counters are recorded by the pulse generator and displayed on the Patient Diagnostics screen:

- Tachy
- Brady

### Ventricular Tachy Counters

Information about Ventricular Episode Counters is available by selecting the Tachy Counters Details button. For each counter, the number of events since last reset and device totals are displayed. Ventricular Episode Counters contains the following data:

- Total Episodes
- VT Episodes ( $V > A$ )
- SVT Episodes ( $V \leq A$ )
- Nonsustained Episodes

### Brady Counters

Information about Brady Counters is displayed by selecting the Brady Counters Details button. This screen displays the Brady episode counters. For each counter, the number of events since last reset and reset before last are displayed. Brady Counters contains the following details:

- Percent of atrial paced
- Percent of RV paced
- Intrinsic Promotion—includes Rate Hysteresis % Successful and AV Search + % Successful

- Atrial Arrhythmia—includes percentage of time in AT/AF, Total Time in AT/AF (min, hr, or days), Episodes by Duration and Total PACs. When at least one ATR event has been stored since the last reset, data for the Longest AT/AF and Fastest VS Rate in AT/AF is presented on the Summary screen and on printed reports (ACCOLADE and PROPONENT devices).

**NOTE:** AT/AF % and Total Time in AT/AF records and displays data for a maximum of one year.

- Ventricular Counters—includes Total PVCs and Three or More PVCs

All Counters can be reset by selecting the Reset button from any Patient Diagnostics Details screen. Counter data can be saved to the PRM and printed via the Reports tab.

## HEART RATE VARIABILITY (HRV)

This feature is available in ACCOLADE and FORMIO devices.

Heart Rate Variability (HRV) is a measure of the changes in a patient's intrinsic heart rate within a 24-hour collection period.

HRV data are collected only in dual chamber devices.

This feature can assist in evaluating the clinical status of heart failure patients.

HRV, as measured by SDANN and HRV Footprint, is an objective, physiological measure that can identify heart failure patients at higher risk of mortality. Specifically, depressed HRV can be used as a predictor of risk of mortality after an acute myocardial infarction.<sup>1</sup> A normal SDANN value is 127 plus or minus 35 ms.<sup>1</sup> Higher SDANN values (indicating greater variability of heart rate) have been associated with lower risk of mortality.<sup>2 3 4</sup> Similarly, a larger HRV Footprint also indicates greater heart rate variability and has been associated with lower mortality risk.<sup>2 3 4</sup>

The HRV monitor feature provides the following information using the intrinsic interval data from the 24-hour collection period that meets the HRV collection criteria (Figure 4-2 on page 4-12):

- Date and time the 24-hour collection period was completed.
- % of Time Used—displays the percentage of time during the 24-hour collection period in which there are valid intrinsic beats. If the % of Time Used falls below 67%, data will not be displayed for that collection period.
- HRV Footprint plot—shows the percentage of the graph area used by the HRV plot. The graph area portrays an “at-a-glance snapshot” of the distribution of variability versus heart rate over a 24-hour period. The trended percentage is a normalized score based on the footprint in the graph.
- Standard Deviation of Averaged Normal R to R intervals (SDANN)—the HRV collection period comprises 288 5-minute segments (24-hours) of intrinsic intervals. The SDANN is the standard deviation of the averages of intrinsic intervals in the 288 5-minute segments. This measurement is also available in the Trends.

1. Electrophysiology Task Force of the European Society of Cardiology and the North American Society of Pacing and Electrophysiology. *Circulation*, 93:1043-1065, 1996.  
 2. F.R. Gilliam et al., *Journal of Electrocardiology*, 40:336-342, 2007.  
 3. F.R. Gilliam et al., *PACE*, 30:56-64, 2007.  
 4. J.P. Singh et al., *Europace*, 12:7-8, 2010.

- Current Normal Brady parameters—Mode, LRL, MTR, and Sensed AV Delay.
- An HRV plot for current and previous collection periods including a line that shows the mean heart rate. The HRV plot summarizes the cardiac variation on a cycle-to-cycle basis. The x-axis shows the heart rate range; the y-axis shows the beat-to-beat variability displayed in milliseconds. The color indicates the frequency of beats at any particular heart rate and heart rate variability combination.

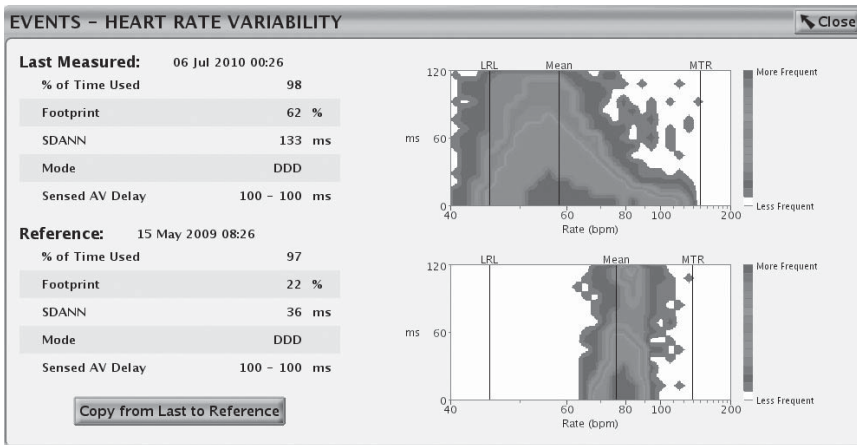

Figure 4-2. Heart Rate Variability display

Consider the following information when using HRV:

- The cardiac cycle (R-R interval) in HRV is determined by RV sensed and paced events.
- Programming the pacing parameters causes the data acquired for the current 24-hour collection period to be invalid.
- The device saves only one set of values and corresponding HRV plot for the Reference portion of the screen. Once the values are copied from Last Measured to Reference, older data cannot be retrieved.
- The first time the HRV feature is used, the Reference screen will show the data from the first valid 24-hour collection period.

Follow the steps below to view HRV:

1. To access the HRV monitor screen, select the Events tab.
2. From the Events screen, select the Patient Diagnostics tab.
3. Select the Heart Rate Variability Details button to view the Last Measured and Reference data.
4. To copy the Last Measured HRV measurements into the Reference section, select the Copy From Last to Reference button.

The HRV monitor screen displays a set of measurements and a HRV plot based on the most recent 24-hour collection period in the Last Measured portion of the screen; measurements from a previously saved collection period are displayed in the Reference portion of the screen. Both collection periods can be viewed simultaneously to compare data that could show trends in the patient's HRV changes

Boston Scientific Confidential. Unauthorized use is prohibited.

LIT APPROVAL - INGENIO 1-2 MRI REF GUIDE US



over a period of time. By saving the Last Measured values to the Reference portion of the screen, you can view the last measured data during a later session.

### **HRV Collection Criteria**

Only valid sinus rhythm intervals are used in the HRV data calculations. For HRV, valid intervals are those which include only valid HRV events.

Valid HRV events are listed below:

- AS with an interval not faster than MTR, followed by a VS
- AS followed by VP at the programmed AV Delay

Invalid HRV events are as follows:

- AP/VS or AP/VP
- AS with an interval faster than MTR
- Non-tracked VP events
- Consecutive AS events (no intervening V event)
- VP-Ns
- Rate Smoothing events (e.g., RVP↑)
- PVC

HRV data may not be reported for a variety of reasons; the most common are as follows:

- Less than 67% of the 24-hour collection period (approximately 16 hours) contains valid HRV events
- Brady Parameters were programmed within the last 24 hours

An example of how HRV data is recorded is shown (Figure 4-3 on page 4-14). In this example, the HRV data in the first collection period is invalid because the Brady Parameters were programmed after the device was taken out of Storage. HRV data is successfully calculated and reported at the end of the second 24-hour collection period. Subsequent HRV data is not reported until the end of Collection Period 5.

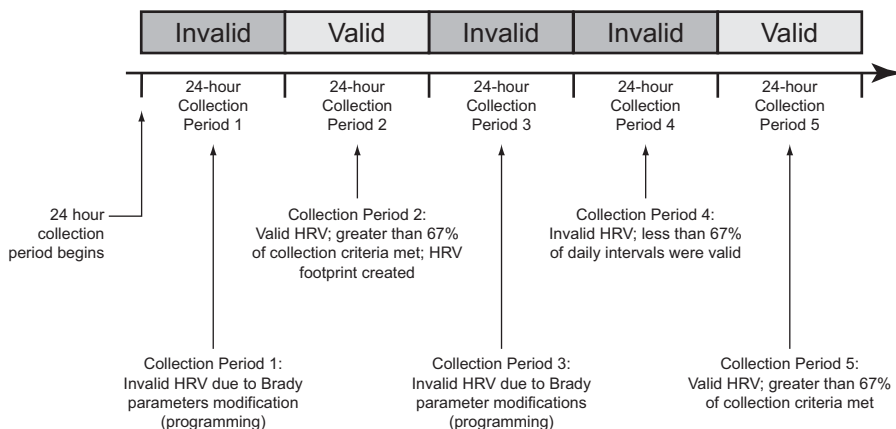

Figure 4-3. Example of HRV data collection

## TRENDS

Trends provide a graphical view of specific patient, device, and lead data. This data can be useful when evaluating your patient’s condition and the effectiveness of programmed parameters. Unless otherwise noted below, data for all trends is reported every 24 hours and is available for up to 1 year. For many trends, a value of “N/R” is reported if there is insufficient or invalid data for the collection period.

The following trends are available:

- Events—displays both atrial and ventricular events stored in the Arrhythmia Logbook, organized by date and type ("Arrhythmia Logbook" on page 4-2). This trend is updated whenever an episode is completed, and may contain data that is older than 1 year.
- Activity Level (ACCOLADE, PROPONENT, FORMIO, VITALIO, and INGENIO devices)—displays a measure of the patient’s daily activity represented by the “Percent of Day Active”.
- AT/AF Burden—displays a trend of the total number of ATR Mode Switch events and the total amount of time spent in an ATR Mode Switch per day.
- RV Rate during AT/AF (ACCOLADE and PROPONENT devices)—displays a trend of the patient’s Mean and Maximum RV rate during ATR events. The Mean rate is calculated using both paced and sensed beats while the Maximum rate is a rolling average of sensed beats. In some cases, the Mean rate may be higher than the Maximum rate.
- Pacing Percent (ACCOLADE and PROPONENT devices)—displays the percentage of paced events for each chamber.
- Respiratory Rate—displays a trend of the patient’s daily minimum, maximum, and median respiratory rate values ("Respiratory Rate Trend" on page 4-16).
- Heart Rate—displays a trend of the patient’s daily maximum, mean, and minimum heart rate. Intervals used in this calculation must be valid sinus rhythm intervals.

The validity of an interval and the Heart Rate Trend data for the 24-hour collection period is determined by the HRV collection criteria ("Heart Rate Variability (HRV)" on page 4-11).

- SDANN (Standard Deviation of Averaged Normal-to-Normal R-R intervals)—displays a trend of the standard deviation of the averages of intrinsic intervals over the 24-hour collection period (which is comprised of 288 5-minute segments). Only intervals that meet the HRV collection criteria are considered valid.

A normal SDANN value is 127 plus or minus 35 ms.<sup>5</sup>

- HRV Footprint—displays the percentage of the graph area used by the HRV Footprint plot, illustrating the distribution of variability versus heart rate over a 24-hour period. The trended percentage is a normalized score based on the footprint in the graph. Refer to additional information about HRV ("Heart Rate Variability (HRV)" on page 4-11).
- ABM (Autonomic Balance Monitor)—displays a trend of the LF/HF ratio.<sup>6</sup> Normal range for the LF/HF ratio is 1.5 - 2.0.<sup>5</sup> ABM is a device calculation based on R–R interval measurements, which mathematically functions as a surrogate measurement for LF/HF ratio. Intervals used in the calculation must be valid sinus rhythm intervals as determined by the HRV collection criteria. If the HRV data is invalid for the 24-hour collection period, then the ABM is not calculated and a value of "N/R" is displayed.
- Lead impedance and amplitude—displays trends of the daily intrinsic amplitude and lead impedance measurements ("Leads Status" on page 3-6).
- A Pace Threshold—displays a trend of the daily right atrial pacing thresholds.
- RV Pace Threshold—displays a trend of the daily right ventricular pacing thresholds.

Follow the steps below to access Trends:

1. From the Events screen, select the Trends Tab.
2. Choose the Select Trends button to specify the trends you want to view. You can choose from the following categories:
  - Heart Failure—includes Heart Rate, SDANN, and HRV Footprint trends.
  - Atrial Arrhythmia—includes AT/AF Burden, RV Rate during AT/AF, and Respiratory Rate (ACCOLADE and PROPONENT devices). For other models, the Atrial Arrhythmia category includes Events, Heart Rate, and AT/AF Burden trends.
  - Activity—includes Heart Rate, Activity Level, and Respiratory Rate trends.
  - Custom—allows you to select various trends to customize the information displayed on the Trends screen.

The display on the screen can be viewed in the following manner:

- Select the desired time on the View button to choose the length of visible trend data.

5. Electrophysiology Task Force of the European Society of Cardiology and the North American Society of Pacing and Electrophysiology. *Circulation*, 93:1043-1065, 1996.
6. Parasympathetic tone is primarily reflected in the high-frequency (HF) component of spectral analysis. The low-frequency (LF) component is influenced by both the sympathetic and parasympathetic nervous systems. The LF/HF ratio is considered a measure of sympathovagal balance and reflects sympathetic modulations. (Source: ACC/AHA Guidelines for Ambulatory Electrocardiography—Part III, JACC VOL. 34, No. 3, September 1999:912–48).  
Boston Scientific Confidential. Unauthorized use is prohibited.

**LIT APPROVAL - INGENIO 1-2 MRI REF GUIDE US**

- Adjust the start and end dates by moving the horizontal slider at the top of the window. You can also adjust these dates using the scroll left and scroll right icons.
- Move the vertical axis across the graph by moving the horizontal slider at the bottom of the display window.

Trends data can be saved to the PRM and printed via the Reports tab. Printed Trends display a timeline which shows PRM and device interactions including programming, office interrogations, and counter resets (ACCOLADE, PROPONENT, ESSENTIO, ALTRUA 2).

### Respiratory Rate Trend

This feature is available in ACCOLADE, PROPONENT, FORMIO, VITALIO, and INGENIO devices.

The Respiratory Rate trend displays a graph of the patient's daily minimum, maximum, and median respiratory rate values. These daily values are stored for up to one year to create a longitudinal display of physiological data.

**NOTE:** *The American College of Cardiology (ACC)/American Heart Association (AHA) guidelines recommend the measurement and documentation of physiological vital signs including respiratory rate for cardiac patients.<sup>7</sup>*

The MV Sensor must be programmed to On or Passive for Respiratory Rate trend data to be collected and displayed ("Minute Ventilation (MV) Sensor" on page 4-16).

Move the horizontal slider over a data point to view the values for a given date. At least 16 hours of data must be collected for values to be calculated and plotted to the Respiratory Rate trend. If insufficient data was collected, no data point will be plotted and there will be a gap in the trend line. This gap will be labeled as N/R to indicate that insufficient or no data was collected.

### Minute Ventilation (MV) Sensor

This feature is available in ACCOLADE, PROPONENT, ESSENTIO, ALTRUA 2, FORMIO, VITALIO, INGENIO, and ADVANTIO devices.

The Minute Ventilation (MV) Sensor uses transthoracic impedance measurements to collect respiration-related data for use in generating the Respiratory Rate trend.

**CAUTION:** Program the MV Sensor to Off during mechanical ventilation. Otherwise, the following may occur:

- Inappropriate MV sensor-driven rate
- Misleading respiration-based trending

Approximately every 50 ms (20 Hz), the pulse generator drives a current excitation waveform between the RA Ring electrode and Can (primary vector). The application of the current between these electrodes creates an electrical field (modulated by respiration) across the thorax. During inspiration, the transthoracic impedance is high, and during expiration it is low. The pulse generator will detect the resulting voltage modulations between the RA Tip electrode and Can. Due to advanced filtering, breathing rates up to 72 breaths per minute are supported.

7. ACC/AHA Heart Failure Clinical Data Standards. *Circulation*, Vol. 112 (12), September 20, 2005.  
Boston Scientific Confidential. Unauthorized use is prohibited.

**CAUTION:** Any medical equipment, treatment, therapy, or diagnostic test that introduces electrical current into the patient has the potential to interfere with pulse generator function.

- External patient monitors (e.g., respiratory monitors, surface ECG monitors, hemodynamic monitors) may interfere with the pulse generator's impedance-based diagnostics (e.g., Respiratory Rate trend). This interference may also result in accelerated pacing, possibly up to the maximum sensor-driven rate, when MV is programmed to On. To resolve suspected interactions with the MV sensor, deactivate the sensor either by programming it to Off (no MV rate driving or MV sensor-based trending will occur), or Passive (no MV rate driving will occur). Alternatively, program the Brady Mode to a non-rate responsive mode (no MV rate driving will occur). If a PRM is not available and the pulse generator is pacing at the sensor-driven rate, apply a magnet to the pulse generator to initiate temporary asynchronous, non-rate responsive pacing.

**NOTE:** *The waveform in a single chamber device will originate from and be measured in the chamber where the lead is located.*

**NOTE:** *The MV Sensor signal does not cause an increase in heart rate if it is programmed to Passive.*

Consider the following when programming the sensor:

- Examine real-time EGMs before and after activating the sensor. The sensor signal can sometimes be observed on EGMs.

**CAUTION:** If MV Sensor signal artifacts are observed on EGMs, and the leads are otherwise shown to be performing appropriately, consider programming the sensor to Off to prevent oversensing.

- Program the sensor to Off if you detect or suspect any loss of lead integrity.

**CAUTION:** Do not program the MV sensor to On until after the pulse generator has been implanted and system integrity has been tested and verified.

The pulse generator may temporarily suspend the sensor in the following circumstances:

- Excessive electrical noise levels—The pulse generator continuously monitors electrical noise levels. The sensor is temporarily suspended if noise is excessive (Sensor Status will indicate Suspended: Noise Detected), and is turned on again when noise decreases to an acceptable level.
- Loss of lead integrity—Lead impedances for the sensor are evaluated every hour (separate from daily lead measurements). If either impedance measurement is out of range, the following occurs:
  - The pulse generator evaluates the lead impedances for a secondary vector driven from the RV Ring electrode to the Can, and measured from the RV Tip electrode to the Can. If these impedance measurement are in range, the sensor reverts to this secondary vector. If either lead impedance is also out of range with the secondary vector, the sensor is suspended for the next hour.

**NOTE:** *If an RA lead is not used, only the secondary vector is available.*

- The pulse generator will continue to monitor lead impedance every hour to determine if the sensor should be returned to the primary or secondary vector, or remain suspended. Acceptable lead impedance values are 200–2000  $\Omega$  for the tip to can vectors and 100–1500  $\Omega$  for the ring to can vectors.

To program the MV Sensor, use the following steps:

1. From the Settings tab on the main screen, select Settings Summary.
2. Select the Brady Settings button.
3. Select the desired option for MV Sensor.

**CAUTION:** To obtain an accurate MV baseline, the MV sensor will be calibrated automatically or can be calibrated manually. A new, manual calibration should be performed if the pulse generator is removed from the pocket following implant, such as during a lead repositioning procedure, or in cases where the MV baseline may have been affected by factors such as lead maturation, air entrapment in the pocket, pulse generator motion due to inadequate suturing, external defibrillation or cardioversion, or other patient complications (e.g., pneumothorax).

## POST IMPLANT FEATURES

### Patient Triggered Monitor (PTM)

This feature is available in ACCOLADE, PROPONENT, ESSENTIO, ALTRUA 2, FORMIO, VITALIO, INGENIO, and ADVANTIO devices.

Patient Triggered Monitor allows the patient to trigger the storage of EGMs, intervals, and annotated marker data during a symptomatic episode by placing a magnet over the device. Instruct the patient to place the magnet on the device briefly and one time only.

Patient Triggered Monitor is enabled by selecting Store EGM as the desired Magnet Response. This can be found in the Timing, Rate Enhancements, Magnet, Noise section on the Brady Settings screen.

When PTM is enabled, the patient can trigger data storage by holding a magnet over the device for at least 2 seconds. The device will store data for up to 2 minutes prior to and up to 1 minute after magnet application. The stored data include the episode number, rates at magnet application, and start time and date of magnet application. After one EGM is generated and stored, PTM is disabled. To store another EGM, the PTM feature must be re-enabled using the programmer. If 60 days elapse and the patient did not trigger data storage, PTM is automatically disabled.

When data are stored, the corresponding episode type is recorded as PTM in the Arrhythmia Logbook.

**CAUTION:** Use care when using Patient Triggered Monitor, because the following conditions will exist while it is enabled:

- All other magnet features, including asynchronous pacing, are disabled. The Magnet feature will not indicate magnet position.
- Device longevity is impacted. To help reduce the longevity impact, PTM only allows storage of one episode, and PTM is automatically disabled after 60 days if data storage was never triggered.
- Once the EGM is stored (or 60 days elapses), PTM is disabled and the device Magnet Response automatically will be set to Pace Async. However, if a magnet is used, the pulse generator will not revert to asynchronous operation until the magnet is removed for 3 seconds and placed on the device again.

To program the Patient Triggered Monitor feature, follow these steps:

Boston Scientific Confidential. Unauthorized use is prohibited.

LIT APPROVAL - INGENIO 1-2 MRI REF GUIDE US

1. From the Settings tab on the main screen, select Settings Summary.
2. From the Settings Summary tab, select Brady Settings.
3. From Brady Settings, select Timing, Rate Enhancements, Magnet, Noise.
4. Program the Magnet Response to Store EGM.
5. Determine if the patient is capable of activating this feature prior to being given the magnet and prior to enabling Patient Triggered Monitor. Remind the patient to avoid strong magnetic fields so the feature is not inadvertently triggered.
6. Consider having the patient initiate a stored EGM at the time Patient Triggered Monitor is enabled to assist with patient education and feature validation. Verify the activation of the feature on the Arrhythmia Logbook screen.

**NOTE:** *Ensure that Patient Triggered Monitor is enabled prior to sending the patient home by confirming the Magnet Response is programmed to Store EGM. If the feature is inadvertently left in the Pace Async setting, the patient could potentially cause the device to pace asynchronously by applying the magnet.*

**NOTE:** *Once the Patient Triggered Monitor feature has been triggered by the magnet and an EGM has been stored, or after 60 days have elapsed from the day that Store EGM was enabled, the Magnet Response programming automatically will be set to Pace Async.*

7. Patient Triggered Monitor can only be enabled for a 60-day period of time. To disable the feature within the 60-day time period, reprogram the Magnet Response to a setting other than Store EGM. When 60 days have passed since enabling Patient Triggered Monitor, the feature will automatically disable itself and the Magnet Response will revert to Pace Async. To re-enable the feature, repeat these steps.

For additional information, contact Boston Scientific using the information on the back cover.

## Magnet Feature

This feature is available in ACCOLADE, PROPONENT, ESSENTIO, ALTRUA 2, FORMIO, VITALIO, INGENIO, and ADVANTIO devices.

The magnet feature allows certain device functions to be triggered when a magnet is placed in close proximity to the pulse generator (Figure 4-4 on page 4-20).

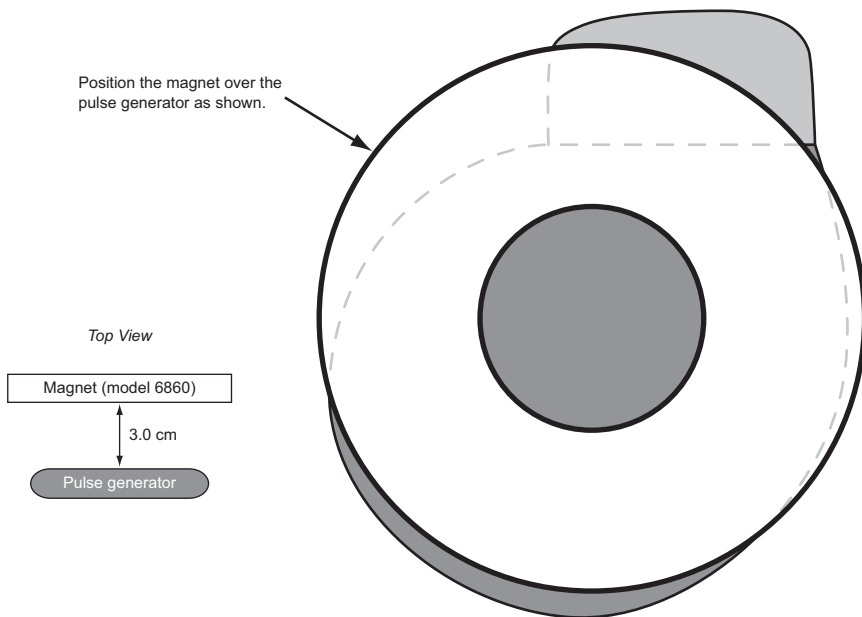

Figure 4-4. Proper position of magnet Model 6860 to activate the pulse generator magnet feature

The pulse generator Magnet Response settings can be programmed to control the behavior of the pulse generator when a magnet is detected. The Magnet Response settings are located in the Timing, Rate Enhancements, Magnet, Noise section of the Brady Settings screen.

The following Magnet Response settings are available:

- Off—no response
- Store EGM—patient monitoring data will be stored
- Pace Async—pacing will occur asynchronously at a rate reflective of the current battery status ("Battery Status Summary Screen" on page 3-3)

#### Off

When the Magnet Response is programmed to Off, application of the magnet will have no effect on the pulse generator.

#### Store EGM

When the Magnet Response is programmed to Store EGM, application of the magnet will activate the Patient Triggered Monitor functionality ("Patient Triggered Monitor (PTM)" on page 4-18).

#### Pace Async

When the Magnet Response is programmed to Pace Async, magnet application converts the pulse generator Brady Mode to an asynchronous mode, with a fixed pacing rate that reflects battery status ("Battery Status Summary Screen" on page 3-3) and magnet AV Delay of 100 ms.

If Magnet Response is programmed to Off, the pulse generator will not revert to asynchronous operation in the presence of magnet. If Magnet Response is programmed to Store EGM, the pulse generator will not revert to asynchronous operation until the magnet is removed for 3 seconds and placed on the device again.



Initial Brady Modes and their corresponding magnet Modes are listed below:

- Brady Modes DDD, DDDR, DDI, and DDIR convert to Magnet Mode DOO
- Brady Modes VDD, VDDR, VVI, and VVIR convert to Magnet Mode VOO
- Brady Modes AAI and AAIR convert to Magnet Mode AOO

The third pulse during the Pace Async Magnet Response will be issued at 50% of the programmed Pulse Width. If loss of capture is observed at the third beat after magnet application, consider re-assessing the safety margin.

The pulse generator remains in Magnet Response as long as the magnet is positioned over the middle of the pulse generator, parallel to the device header. When the magnet is removed, the pulse generator automatically resumes operating according to previously programmed parameters.

**NOTE:** *If rate adaptive pacing or PaceSafe Right Ventricular Automatic Capture has been programmed, it is suspended for the duration of magnet application. Output is set to twice the last threshold measurement and there is no beat to beat capture verification for the duration of magnet application.*

**NOTE:** *The magnet feature is suspended when the pulse generator is in MRI Protection Mode.*



## ELECTROPHYSIOLOGIC TESTING

---

### CHAPTER 5

This chapter contains the following topics:

- "EP Test Features" on page 5-2
- "Induction Methods" on page 5-3

## EP TEST FEATURES

Electrophysiologic (EP) Testing features enable you to induce and terminate arrhythmias noninvasively.

**WARNING:** Always have external defibrillation equipment available during implant and electrophysiologic testing. If not terminated in a timely fashion, an induced ventricular tachyarrhythmia can result in the patient's death.

The features allowing noninvasive EP testing of arrhythmias include the following:

- Programmed electrical stimulation (PES) induction/termination
- Manual Burst pacing induction/termination

### EP Test Screen

The EP Test screen displays the real-time status of the episode detection and brady pacing therapy of the pulse generator when telemetry communication is occurring.

Refer to the EP Test screen (Figure 5-1 on page 5-2):

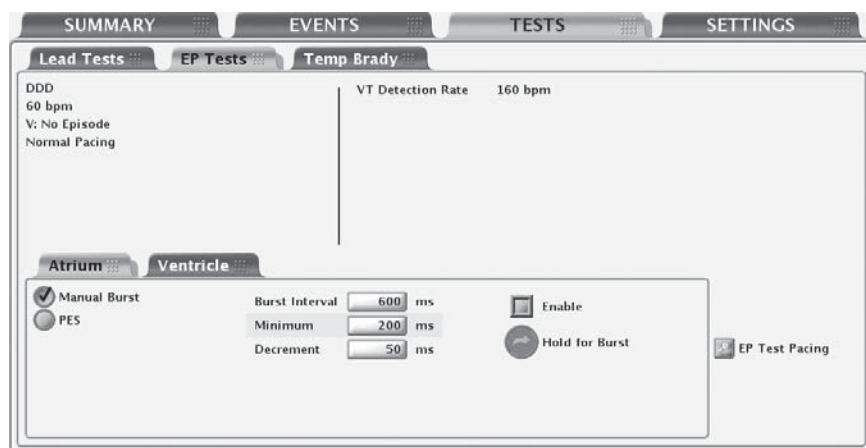

Figure 5-1. EP Test Screen

The screen provides the following information:

- Ventricular episode status—if an episode is occurring, the duration of the episode is displayed (if it is greater than 10 minutes, then it is displayed as > 10:00 m:s)
- Atrial episode status—if an episode is occurring, the duration of the episode is displayed (if it is greater than 100 minutes, then it is displayed as > 99:59 m:s)

**NOTE:** Single-chamber devices use ventricular-based episode reporting.

- Brady pacing status

Follow the steps below to perform EP Test functions:

1. Select the Tests tab, then select the EP Tests tab.

2. Establish telemetry communication. Telemetry communication between the programmer and the pulse generator should be maintained throughout all EP test procedures.
3. Set Backup Pacing and EP Test Pacing Outputs as desired.

**NOTE:** Backup Pacing during EP testing is not available in single-chamber devices.

## INDUCTION METHODS

Each EP Test method available from the EP Test screen is described below with instructions. During any type of induction/termination, the pulse generator performs no other activity until the test has ceased, at which time the programmed mode will take effect and the pulse generator will respond accordingly.

Consider the following information when using these methods:

- Pacing pulses during induction are delivered at the programmed EP Test pacing parameters

### Backup Ventricular Pacing During Atrial EP Testing

Backup ventricular pacing is available during atrial EP testing (PES, Manual Burst) regardless of the programmed Normal Brady Mode.

**NOTE:** Backup Pacing is performed in VOO mode.

**NOTE:** Backup Pacing during EP testing is not available in single-chamber devices.

In dual-chamber devices, program the backup pacing parameters by selecting the EP Test Pacing button. Backup Pacing parameters are independently programmable from the permanent pacing parameters. Backup Pacing can also be disabled by programming the Backup Pacing Mode to Off.

### Programmed Electrical Stimulation (PES)

PES induction allows the pulse generator to deliver up to 30 equally timed pacing pulses (S1) followed by up to 4 premature stimuli (S2–S5) to induce or terminate arrhythmias. Drive pulses, or S1 pulses, are intended to capture and drive the heart at a rate slightly faster than the intrinsic rate. This ensures that the timing of the premature extra stimuli will be accurately coupled with the cardiac cycle (Figure 5-2 on page 5-4).

The initial S1 pulse is coupled to the last sensed or paced beat at the S1 Interval. All pulses are delivered in XOO modes (where X is the chamber) at the programmed EP Test pacing parameters.

For Atrial PES, backup pacing parameters are provided.

**NOTE:** Backup Pacing during EP testing is not available in single-chamber devices.

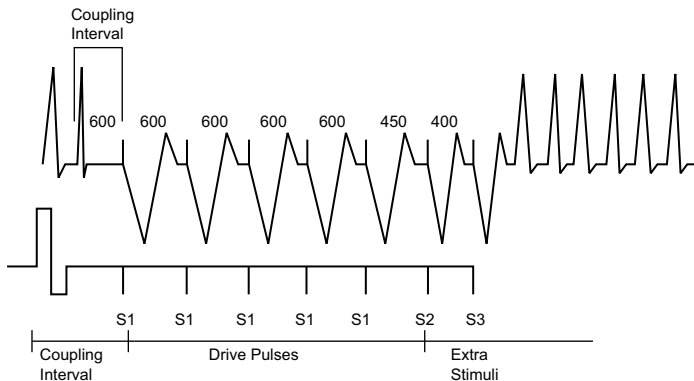

Figure 5-2. PES induction drive train

### Performing PES Induction

1. In a dual-chamber device, choose the Atrium or Ventricle tab, depending on which chamber you want to pace.
2. Select the PES option. Buttons for the S1–S5 pulses and the corresponding burst cycle lengths are displayed.
3. Select the desired value for the S1–S5 intervals (Figure 5-3 on page 5-4). You can either select a value box for the desired S interval and choose a value from the box or use the plus or minus symbols to change the value visible in the value box.

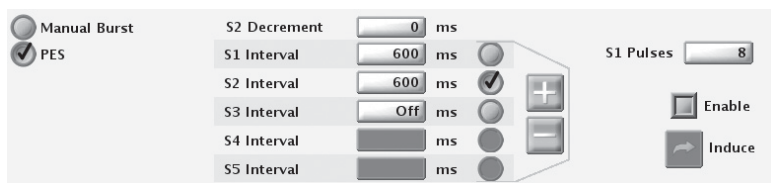

Figure 5-3. PES induction options

4. Select the Enable checkbox.
5. Select (do not hold) the Induce button to begin delivery of the drive train. When the programmed number of S1 pulses is delivered, the pulse generator will then deliver the programmed S2–S5 pulses. The pulses are delivered in sequence until a pulse is encountered that is set to Off (e.g., if S1 and S2 are set to 600 ms, and S3 is Off, then S3, S4, and S5 will not be delivered). Once induction is initiated, the PES delivery will not stop if you interrupt telemetry communication. (While telemetry is active, pressing the DIVERT THERAPY key will stop induction delivery.)
6. PES induction is complete when the drive train and extra stimuli are delivered, at which time the pulse generator automatically restarts detection.

**NOTE:** Ensure the PES induction is complete before beginning another induction.

**NOTE:** When PES is used to terminate an arrhythmia that has been detected (and an episode declared), the episode is terminated when the PES is commanded regardless of whether it is successful or not. A new episode can be declared after the PES induction is completed. The PES itself is not recorded in therapy history; this may result in several episodes being counted in therapy history.

Boston Scientific Confidential. Unauthorized use is prohibited.

LIT APPROVAL - INGENIO 1-2 MRI REF GUIDE US

**NOTE:** Real-time EGMs and annotated event markers will continue to be displayed during the entire test sequence.

## Manual Burst Pacing

Manual Burst pacing is used to induce or terminate arrhythmias when delivered to the desired chamber. Pacing parameters are programmable for Manual Burst.

Manual Burst pacing pulses are delivered in XOO mode (where X is the chamber) at the programmed EP Test pacing parameters. For Atrial Manual Burst, backup pacing parameters are provided.

**NOTE:** Backup Pacing during EP testing is not available in single-chamber devices.

### Performing Manual Burst Pacing

1. In a dual-chamber device, choose the Atrium or Ventricle tab, depending on which chamber you want to pace.
2. Select the Manual Burst option.
3. Select the desired value for the Burst Interval, Minimum, and Decrement. This indicates the cycle length of the intervals in the drive train.
4. Select the Enable checkbox.
5. To deliver the burst, select and hold the Hold for Burst button.

The ventricular Manual Burst will be delivered up to 30 seconds as long as the Hold for Burst button is held and the telemetry link is maintained.

The atrial Manual Burst will be delivered up to 45 seconds as long as the Hold for Burst button is held and the telemetry link is maintained.

The intervals will continue to be decremented until the Minimum interval is reached, then all further pulses will be at the Minimum interval.

**NOTE:** In single-chamber devices, the 30 second burst time limit is used.

6. To stop the burst delivery, release the Hold for Burst button. The Hold for Burst button will become dimmed again.
7. To deliver additional Manual Burst pacing, repeat these steps.

**NOTE:** Real-time EGMs and annotated event markers will continue to be displayed during the entire test sequence.

Boston Scientific Confidential. Unauthorized use is prohibited.

**LIT APPROVAL - INGENIO 1-2 MRI REF GUIDE US**



## PROGRAMMABLE OPTIONS

### APPENDIX A

Table A-1. ZIP Telemetry settings

Parameter	Programmable Values	Nominal <sup>a</sup>
Communication Mode	Enable use of ZIP telemetry (May require limited use of wand); Use wand for all telemetry	Enable use of ZIP telemetry (May require limited use of wand)

a. If the Communication Mode is selected via the Utilities button on the PRM Startup screen, the Nominal setting within the ZOOMVIEW Programmer software application will correspond to the value chosen on the Startup screen.

Table A-2. Device Mode

Parameter	Programmable Values	Nominal
Device Mode	Exit Storage; Enable Electrocautery Protection; Enable MRI Protection	Storage

Table A-3. Pacing therapy parameters (specified into a 750  $\Omega$  load)

Parameter	Programmable Values	Nominal
Mode <sup>a b d</sup>	DDD(R); DDI(R); DOO; VDD(R); VVI(R); VOO; AAI(R); AOO; Off; Temporary: DDD; DDI; DOO; VDD; VVI; VOO; AAI; AOO; Off	Dual Chamber: DDD; Single Chamber: VVI
Lower Rate Limit (LRL) <sup>a c d</sup> (ppm)	30; 35; ...; 185	60 (Tolerance $\pm$ 5 ms)
Maximum Tracking Rate (MTR) <sup>a d</sup> (ppm)	50; 55; ...; 185	130 (Tolerance $\pm$ 5 ms)
Maximum Sensor Rate (MSR) <sup>f</sup> (ppm)	50; 55; ...; 185	130 (Tolerance $\pm$ 5 ms)
Pulse Amplitude <sup>a d e j</sup> (dual chamber, atrium) (V)	Auto; 0.1; 0.2; ...; 3.5; 4.0; ...; 5.0; Temporary: 0.1; 0.2; ...; 3.5; 4.0; ...; 5.0	3.5 (Tolerance $\pm$ 15% or 100 mV, whichever is greater)
Pulse Amplitude <sup>a d e</sup> (dual chamber, right ventricle) (V)	Auto; 0.1; 0.2; ...; 3.5; 4.0; ...; 7.5; Temporary: 0.1; 0.2; ...; 3.5; 4.0; ...; 7.5	3.5 (Tolerance $\pm$ 15% or 100 mV, whichever is greater)
Pulse Amplitude <sup>a d e</sup> (single chamber) (V)	Auto; 0.1; 0.2; ...; 3.5; 4.0; ...; 7.5; Temporary: 0.1; 0.2; ...; 3.5; 4.0; ...; 7.5	3.5 (Tolerance $\pm$ 15% or 100 mV, whichever is greater)
Pulse Amplitude Daily Trend <sup>g</sup> (independently programmable in each chamber that has the Pacesafe feature)	Disabled; Enabled	Enabled (ACCOLADE, PROPONENT, ESSENTIO, and ALTRUA 2 devices)  Disabled (FORMIO, VITALIO, INGENIO, and ADVANTIO devices)
Pulse Width <sup>a d e h</sup> (atrium, right ventricle) (ms)	0.1; 0.2; ...; 2.0	0.4 (Tolerance $\pm$ 0.03 ms at < 1.8 ms; $\pm$ 0.08 ms at $\geq$ 1.8 ms)
Accelerometer <sup>f</sup>	On; Passive	Passive
Accelerometer Activity Threshold	Very Low; Low; Medium Low; Medium; Medium High; High; Very High	Medium
Accelerometer Reaction Time (sec)	10; 20; ...; 50	30
Accelerometer Response Factor	1; 2; ...; 16	8
Accelerometer Recovery Time (min)	2; 3; ...; 16	2
Minute Ventilation <sup>f</sup>	On; Passive; Off	Passive
Minute Ventilation Response Factor	1; 2; ...; 16	8
Minute Ventilation Fitness Level	Sedentary; Active; Athletic; Endurance Sports	Active
Patient's Age <sup>i</sup>	$\leq$ 5; 6–10; 11–15; ...; 91–95; $\geq$ 96	56–60

Boston Scientific Confidential. Unauthorized use is prohibited.

LIT APPROVAL - INGENIO 1-2 MRI REF GUIDE US

**Table A-3. Pacing therapy parameters (specified into a 750 Ω load) (continued)**

Parameter	Programmable Values	Nominal
Patient's Gender <sup>i</sup>	Male; Female	Male
Ventilatory Threshold ( ppm)	30; 35; ...; 185	120 (Tolerance ± 5 ms)
Ventilatory Threshold Response (%)	Off; 85; 70; 55	70
Rate Hysteresis Hysteresis Offset <sup>f</sup> ( ppm)	-80; -75; ...; -5; Off	Off (Tolerance ± 5 ms)
Rate Hysteresis Search Hysteresis <sup>f</sup> (cycles)	Off; 256; 512; 1024; 2048; 4096	Off (Tolerance ± 1 cycle)
Rate Smoothing (Up, Down) <sup>f</sup> (%)	Off; 3; 6; 9; 12; 15; 18; 21; 25	Off (Tolerance ± 1%)
Rate Smoothing Maximum Pacing Rate ( ppm)	50; 55; ...; 185	130 (Tolerance ± 5 ms)
Sudden Brady Response (SBR) <sup>f</sup>	Off; On	Off
SBR Atrial Paces Before Therapy	1; 2; ...; 8	3
SBR Atrial Pacing Rate Increase ( ppm)	5; 10; ...; 40	20
SBR Therapy Duration (min)	1; 2; ...; 15	2
SBR Inhibit During Rest	Off; On	On
Atrial Pace/Sense Configuration <sup>a d</sup> (dual chamber)	Unipolar; Bipolar; Bipolar/Unipolar; Unipolar/Bipolar; Unipolar/Off; Bipolar/Off	Bipolar
Right Ventricle Pace/Sense Configuration <sup>a d</sup> (dual chamber)	Unipolar; Bipolar; Bipolar/Unipolar; Unipolar/Bipolar	Bipolar
Pace/Sense Configuration <sup>a d</sup> (single chamber)	Unipolar; Bipolar; Bipolar/Unipolar; Unipolar/Bipolar	Bipolar
Safety Switch (independently programmable in each chamber)	Off; On	On
Maximum Paced AV Delay <sup>a d</sup> (ms)	30; 40; ...; 400	180 (Tolerance ± 5 ms)
Minimum Paced AV Delay <sup>a d</sup> (ms)	30; 40; ...; 400	80 (Tolerance ± 5 ms)
Maximum Sensed AV Delay <sup>a d</sup> (ms)	30; 40; ...; 400	150 (Tolerance ± 5 ms)
Minimum Sensed AV Delay <sup>a d</sup> (ms)	30; 40; ...; 400	65 (Tolerance ± 5 ms)
AV Search + <sup>f</sup>	Off; On	Off
AV Search + Search AV Delay (ms)	30; 40; ...; 400	300 (Tolerance ± 5 ms)
AV Search + Search Interval (cycles)	32; 64; 128; 256; 512; 1024	32 (Tolerance ± 1 cycle)
RHYTHMIQ <sup>f</sup>	AAI(R) with VVI Backup; Off	Off
Maximum A-Refractory (PVARP) <sup>a d</sup> (dual chamber) (ms)	150; 160; ...; 500	280 (Tolerance ± 5 ms)
Minimum A-Refractory (PVARP) <sup>a d</sup> (dual chamber) (ms)	150; 160; ...; 500	240 (Tolerance ± 5 ms)
Maximum V-Refractory (VRP) <sup>a d</sup> (dual chamber) (ms)	150; 160; ...; 500	250 (Tolerance ± 5 ms)
Minimum V-Refractory (VRP) <sup>a d</sup> (dual chamber) (ms)	150; 160; ...; 500	230 (Tolerance ± 5 ms)
Maximum Refractory <sup>a d</sup> (single chamber) (ms)	150; 160; ...; 500	250 (Tolerance ± 5 ms)
Minimum Refractory <sup>a d</sup> (single chamber) (ms)	150; 160; ...; 500	250 (Tolerance ± 5 ms)
PVARP after PVC <sup>a</sup> (ms)	Off; 150; 200; ...; 500	400 (Tolerance ± 5 ms)
A-Blank after V-Pace <sup>a d k</sup> (ms)	Smart; 45; 65; 85; 105; 125; 150; 175; 200	125 (Tolerance ± 5 ms)
A-Blank after V-Sense <sup>a d k</sup> (ms)	Smart; 45; 65; 85	45 (Tolerance ± 5 ms)
V-Blank after A-Pace <sup>a d</sup> (ms)	45; 65; 85	65 (Tolerance ± 5 ms)

Boston Scientific Confidential. Unauthorized use is prohibited.

**LIT APPROVAL - INGENIO 1-2 MRI REF GUIDE US**

**Table A-3. Pacing therapy parameters (specified into a 750 Ω load) (continued)**

Parameter	Programmable Values	Nominal
Noise Response <sup>a</sup>	AOO; VOO; DOO; Inhibit Pacing	DOO for DDD(R) and DDI(R) modes; VOO for VDD(R) and VVI (R) modes; AOO for AAI(R) mode
Magnet Response	Off; Store EGM; Pace Async	Pace Async

- a. The programmed Normal Brady values will be used as the nominal values for Temporary Brady pacing.
- b. Refer to the NASPE/BPEG codes below for an explanation of the programmable values. The identification code of the North American Society of Pacing and Electrophysiology (NASPE) and the British Pacing and Electrophysiology Group (BPEG) is based on the categories listed in the table.
- c. The basic pulse period is equal to the pacing rate and the pulse interval (no hysteresis). Runaway protection circuitry inhibits bradycardia pacing above 205 ppm. Magnet application may affect pacing rate (test pulse interval).
- d. Separately programmable for Temporary Brady.
- e. For FORMIO, VITALIO, INGENIO, and ADVANTIO devices, values are not affected by temperature variation within the range 20°C – 43°C. For ACCOLADE, PROPONENT, ESSENTIO, and ALTRUA 2 devices, values are not affected by temperature variation within the range 20°C – 45°C.
- f. This parameter is disabled during Temporary Brady.
- g. This parameter is automatically enabled if Auto is selected for the Pulse Amplitude.
- h. When the Pulse Amplitude is set to Auto or Pulse Amplitude Daily Trend is enabled the Pulse Width is fixed at 0.4 ms.
- i. This parameter is used for calculating Ventilatory Threshold Response.
- j. Auto is available in models which contain the Pacesafe feature.
- k. Smart is available when AGC is selected as the Sensing Method.

**Table A-4. Brady Mode values based on NASPE/BPEG codes**

Position	I	II	III	IV	V
Category	Chambers Paced	Chambers Sensed	Response to Sensing	Programmability, rate modulation	Antitachyarrhythmia Functions
Letters	0–None	0–None	0–None	0–None	0–None
	A–Atrium	A–Atrium	T–Triggered	P–Simple Programmable	P–Pacing (Antitachyarrhythmia)
	V–Ventricle	V–Ventricle	I–Inhibited	M–Multiprogrammable	S–Shock
	D–Dual (A&V)	D–Dual (A&V)	D–Dual (T&I)	C–Communicating	D–Dual (P&S)
				R–Rate Modulation	
Mfrs. Designation Only	S–Single (A or V)	S–Single (A or V)			

**Table A-5. MRI Protection parameters**

Parameter	Programmable Values	Nominal
MRI Brady Mode	Off; VOO; AOO; DOO	DOO for DDD(R), DDI(R), or DOO normal Brady modes; VOO for VDD(R), VVI(R), or VOO normal Brady modes; AOO for AAI(R) or AOO normal Brady Mode; Off for Normal Brady Mode Off
MRI Lower Rate Limit (LRL) ( ppm)	30; 35; ...; 100	20 ppm above the normal mode LRL
MRI Atrial Amplitude (V)	2.0; 2.1; ...; 3.5; 4.0; ...; 5.0	5.0 (Tolerance ± 15% or ± 100 mV, whichever is greater) <sup>a</sup>
MRI Ventricular Amplitude (V)	2.0; 2.1; ...; 3.5; 4.0; ...; 5.0	5.0 (Tolerance ± 15% or ± 100 mV, whichever is greater) <sup>a</sup>
MRI Protection Time-out (hours)	Off; 12; 24; 48	24

- a. During the transition into the MRI Protection Mode, it may take up to 6 cardiac pacing cycles for the pace amplitude to meet the specified tolerance range.

**Table A-6. Sensor Trending**

Parameter	Programmable Values	Nominal
Recording Method	Beat To Beat; Off; 30 Second Average	30 Second Average
Data Storage	Continuous; Fixed	Continuous

**Table A-7. Ventricular Tachy EGM Storage**

Parameter	Programmable Values	Nominal
Tachy EGM Storage (single chamber models)	Off; On	On
Ventricular Tachy EGM Storage (dual chamber models)	Off; On	On
Tachy Detection Rate <sup>a</sup> (single chamber models) ( bpm)	90; 95; ...; 210; 220	160 (Tolerance ± 5 ms)
VT Detection Rate <sup>b</sup> (dual chamber models) ( bpm)	90; 95; ...; 210; 220	160 (Tolerance ± 5 ms)

- a. The Tachy Detection Rate must ≥ 5 bpm higher than the Maximum Sensor Rate and the Maximum Pacing Rate, and must be ≥ 15 bpm higher than the Lower Rate Limit.
- b. The VT Detection Rate must be ≥ 5 bpm higher than the Maximum Tracking Rate, Maximum Sensor Rate, and the Maximum Pacing Rate, and must be ≥ 15 bpm higher than the Lower Rate Limit.

**Table A-8. Atrial Tachy Parameters**

Parameter	Programmable Values	Nominal
ATR Mode Switch <sup>a</sup>	Off; On	On
ATR Trigger Rate <sup>a c</sup> ( bpm)	100; 110; ...; 300	170 (Tolerance ± 5 ms)
ATR Duration <sup>a</sup> (cycles)	0; 8; 16; 32; 64; 128; 256; 512; 1024; 2048	8 (Tolerance ± 1 cardiac cycle)
ATR Entry Count <sup>a</sup> (cycles)	1; 2; ...; 8	8
ATR Exit Count <sup>a</sup> (cycles)	1; 2; ...; 8	8
ATR Fallback Mode <sup>d</sup>	VDI; DDI; VDIR; DDIR	DDI
ATR Fallback Time <sup>a</sup> (min:sec)	00:00; 00:15; 00:30; 00:45; 01:00; 01:15; 01:30; 01:45; 02:00	00:30
ATR Fallback LRL <sup>a</sup> ( ppm)	30; 35; ...; 185	70 (Tolerance ± 5 ms)
ATR Ventricular Rate Regulation (VRR) <sup>a</sup>	Off; On	On
ATR Maximum Pacing Rate (MPR) <sup>a</sup> ( ppm)	50; 55; ...; 185	130 (Tolerance ± 5 ms)
Atrial Flutter Response <sup>b</sup>	Off; On	On
Atrial Flutter Response Trigger Rate <sup>c</sup> ( bpm)	100; 110; ...; 300	170 (Tolerance ± 5 ms)
PMT Termination <sup>b</sup>	Off; On	On
Ventricular Rate Regulation (VRR) <sup>b</sup>	Off; On	Off
VRR Maximum Pacing Rate (MPR) ( ppm)	50; 55; ...; 185	130 (Tolerance ± 5 ms)

- a. The programmed Normal Brady values will be used as the nominal values for Temporary Brady pacing.
- b. This parameter gets disabled during Temporary Brady.
- c. ATR Trigger Rate and Atrial Flutter Response Trigger Rate are linked. If either of these rates is reprogrammed, the other will automatically change to the same value.
- d. If Normal Brady ATR Fallback Mode is DDIR or DDI, then Temporary Brady ATR Fallback Mode is DDI. If Normal Brady ATR Fallback Mode is VDIR or VDI, then Temporary Brady ATR Fallback Mode is VDI.

**Table A-9. Sensitivity**

Parameter <sup>a b c</sup>	Programmable Values	Nominal
Sensing Method <sup>d</sup>	AGC; Fixed	Fixed
Atrial Sensitivity (AGC) (mV)	AGC 0.15; AGC 0.2; AGC 0.25; AGC 0.3; AGC 0.4; ...; AGC 1.0; AGC 1.5	AGC 0.25

Boston Scientific Confidential. Unauthorized use is prohibited.

LIT APPROVAL - INGENIO 1-2 MRI REF GUIDE US

**Table A-9. Sensitivity** (continued)

Parameter <sup>a b c</sup>	Programmable Values	Nominal
Right Ventricular Sensitivity (AGC) (mV)	AGC 0.15; AGC 0.2; AGC 0.25; AGC 0.3; AGC 0.4; ...; AGC 1.0; AGC 1.5	AGC 0.6
Atrial Sensitivity (Fixed) (mV)	Fixed 0.15; Fixed 0.25; Fixed 0.5; Fixed 0.75; Fixed 1.0; Fixed 1.5; ...; Fixed 8.0; Fixed 9.0; Fixed 10.0	Fixed 0.75
Right Ventricular Sensitivity (Fixed) (mV)	Fixed 0.25; Fixed 0.5; Fixed 0.75; Fixed 1.0; Fixed 1.5; ...; Fixed 8.0; Fixed 9.0; Fixed 10.0	Fixed 2.5

a. Separately programmable for Temporary Brady.

b. The programmed Normal Brady values will be used as the nominal values for Temporary Brady pacing.

c. In single-chamber models, the chamber chosen determines the nominal value.

d. The programmed value for Sensing Method determines the applicable values (AGC or Fixed) in each chamber.

**Table A-10. Daily Lead Measurements**

Parameter	Programmable Values	Nominal
Atrial Intrinsic Amplitude	On; Off	On
Ventricular Intrinsic Amplitude	On; Off	On
Intrinsic Amplitude (single-chamber models)	On; Off	On
Atrial Pace Impedance	On; Off	On
Ventricular Pace Impedance	On; Off	On
Pace Impedance (single-chamber models)	On; Off	On
Atrial Low Impedance Limit ( $\Omega$ )	200; 250; ...; 500	200
Atrial High Impedance Limit ( $\Omega$ )	2000; 2250;...; 3000	2000
Ventricular Low Impedance Limit ( $\Omega$ )	200; 250; ...; 500	200
Ventricular High Impedance Limit ( $\Omega$ )	2000; 2250;...; 3000	2000
Low Impedance Limit ( $\Omega$ ) (single-chamber models)	200; 250; ...; 500	200
High Impedance Limit ( $\Omega$ ) (single-chamber models)	2000; 2250;...; 3000	2000
Post-Operative System Test (POST) (hours)	Off; 2; 3; ...; 24	4

**Table A-11. Backup EP Test**

Parameter	Programmable Values	Nominal
Backup Pacing Mode <sup>a c</sup>	Off; On	On
Backup Pacing Lower Rate Limit <sup>a b c</sup> (ppm)	30; 35; ...; 185	60 (Tolerance $\pm$ 5 ms)
Backup Pacing V Refractory <sup>a b c</sup> (ms)	150; 160; ...; 500	250 (Tolerance $\pm$ 5 ms)
EP Test Pacing Outputs Atrial Amplitude (dual-chamber models when test is in the atrium) (V)	Off; 0.1; 0.2; ...; 3.5; 4.0; ...; 5.0	5.0 (Tolerance $\pm$ 15% or 100 mV, whichever is greater)
EP Test Pacing Outputs Amplitude (single-chamber models) (V)	Off; 0.1; 0.2; ...; 3.5; 4.0; ...; 7.5	7.5 (Tolerance $\pm$ 15% or 100 mV, whichever is greater)
EP Test Pacing Outputs V Amplitude (dual chamber models) (V)	Off; 0.1; 0.2; ...; 3.5; 4.0; ...; 7.5	7.5 (Tolerance $\pm$ 15% or 100 mV, whichever is greater)
EP Test Pacing Outputs Atrial Pulse Width (dual-chamber models when test is in the atrium) (ms)	0.1; 0.2; ...; 2.0	1.0 (Tolerance $\pm$ 0.03 ms at $<$ 1.8 ms; $\pm$ 0.08 ms at $\geq$ 1.8 ms)

Boston Scientific Confidential. Unauthorized use is prohibited.

LIT APPROVAL - INGENIO 1-2 MRI REF GUIDE US

**Table A-11. Backup EP Test (continued)**

Parameter	Programmable Values	Nominal
EP Test Pacing Outputs Pulse Width (single-chamber models) (ms)	0.1; 0.2; ...; 2.0	1.0 (Tolerance $\pm$ 0.03 ms at < 1.8 ms; $\pm$ 0.08 ms at $\geq$ 1.8 ms)
EP Test Pacing Outputs V Pulse Width (dual-chamber models) (ms)	0.1; 0.2; ...; 2.0	1.0 (Tolerance $\pm$ 0.03 ms at < 1.8 ms; $\pm$ 0.08 ms at $\geq$ 1.8 ms)

- a. This parameter only applies when the test is in the atrium.
- b. The programmed Normal Brady value will be used as the nominal value.
- c. Not applicable to single-chamber models.

**Table A-12. PES (Programmed Electrical Stimulation)**

Parameter <sup>a</sup>	Programmable Values	Nominal
Number of S1 Intervals (pulses)	1; 2; ...; 30	8
S2 Decrement (ms)	0; 10; ...; 50	0
S1 Interval (ms)	120; 130; ...; 750	600 (Tolerance $\pm$ 5 ms)
S2 Interval (ms)	Off; 120; 130; ...; 750	600 (Tolerance $\pm$ 5 ms)
S3 Interval (ms)	Off; 120; 130; ...; 750	Off (Tolerance $\pm$ 5 ms)
S4 Interval (ms)	Off; 120; 130; ...; 750	Off (Tolerance $\pm$ 5 ms)
S5 Interval (ms)	Off; 120; 130; ...; 750	Off (Tolerance $\pm$ 5 ms)

- a. Applied to the atrium or ventricle as commanded by the programmer.

**Table A-13. Manual Burst Pacing**

Parameter <sup>a</sup>	Programmable Values	Nominal
Burst Interval (ms)	100; 110; ...; 750	600 (Tolerance $\pm$ 5 ms)
Minimum Interval (ms)	100; 110; ...; 750	200 (Tolerance $\pm$ 5 ms)
Decrement (ms)	0; 10; ...; 50	50 (Tolerance $\pm$ 5 ms)

- a. Applied to the atrium or ventricle depending on the chamber selected.

# SYMBOLS ON PACKAGING

## APPENDIX B

### SYMBOLS ON PACKAGING

The following symbols may be used on packaging and labeling (Table B-1 on page B-1):

Table B-1. Symbols on packaging

























Symbol	Description
	Reference number
	Package contents
	Pulse generator
	Torque wrench
	Literature enclosed
	Serial number
	Use by
	Lot number
	Date of manufacture
	Sterilized using ethylene oxide
	Do not resterilize
	Do not reuse
	Do not use if package is damaged
	Consult instructions for use
	Temperature limitation
	Place telemetry wand here

Table B-1. Symbols on packaging (continued)

Symbol	Description
	Open here
	Authorized Representative in the European Community
	Manufacturer
	MR Conditional
	Pacemaker RV
	Pacemaker RA, RV
	CRT-P RA, RV, LV
	Uncoated device
	RF Telemetry



# INDEX

## A

- A-blank
  - after RV-sense 2-68
  - after V-pace 2-67
- A-tachy response (ATR)
  - mode switch 2-43
- ABM (Autonomic Balance Monitor) 4-15
- Accelerometer 2-27
  - activity threshold 2-28
  - reaction time 2-29
  - recovery time 2-30
  - response factor 2-27
- Activity threshold 2-28
- Adaptive-rate pacing 2-26
- AGC (automatic gain control) 2-23
- Amplitude 2-13
  - intrinsic test 3-12
- Application screen 1-2
- Arrhythmia logbook 4-2
  - episode detail 4-5
  - events summary 4-5
  - interval 4-6
  - stored EGM 4-5
  - Ventricular Tachy EGM Storage 4-7
- ATR (atrial tachy response)
  - atrial flutter response 2-46
  - duration 2-44
  - end of ATR episode 2-45
  - entry count 2-44
  - exit count 2-44
  - LRL, fallback 2-45
  - maximum pacing rate 2-46
  - mode switch 2-43
  - mode, fallback 2-45
  - PMT termination 2-47
  - rate threshold 2-44
  - time, fallback 2-45
  - ventricular rate regulation 2-45
- ATR Trigger Rate 2-44
- Atrial
  - refractory period, post ventricular atrial (PVARP) 2-63
  - refractory period, same chamber 2-65
  - use of atrial information 2-55
- Atrial flutter response 2-46
- Atrial tachy
  - ATR mode switch 2-43
  - atrial flutter response 2-46
  - PMT termination 2-47
  - ventricular rate regulation 2-45
- Attention conditions, yellow 1-7
- Automatic capture
  - RVAC 2-17
- Automatic threshold

- RAAT 2-13
- AV delay 2-57
  - paced 2-57
  - RYTHMIQ 2-61
  - sensed 2-58
- AV Delay
  - Search 2-60
- AV Search + 2-60
  - Search AV Delay 2-60
  - Search Interval 2-61

## B

- Backup ventricular pacing during atrial stimulation, EP test 5-3
- Battery
  - Explant status 3-4
  - icon 1-5
  - indicator 3-4
  - status 3-2
- Blanking 2-66
  - A-blank after RV-sense 2-68
  - A-blank after V-pace 2-67
  - RV-blank after A-pace 2-67
- Blended Sensors 2-39
- Brady Tachy Response (BTR) 2-67
- Burst
  - pacing, manual burst 5-5
- Buttons, software 1-5

## C

- Check
  - icon 1-5
- Communication, telemetry
  - Radio frequency (RF) 1-8
- Continue
  - icon 1-6
- Counter
  - brady 4-10
  - therapy history 4-10
  - ventricular 4-10

## D

- Daily measurements 3-6
- Data
  - disk 1-18
  - patient 1-18

- storage 1-18
- USB 1-18
- Demonstration
  - Programmer/recorder/monitor (PRM) mode 1-3, 1-8
- Detail icon 1-5
- Device
  - memory 1-19
- Device Modes 2-2
- Diagnostic
  - battery status 3-2
  - heart rate variability (HRV) 4-11
  - histogram 4-9
  - lead test 3-11
  - patient triggered monitor 4-18
- Disk
  - data 1-18
  - read 1-18
  - save 1-18
- DIVERT THERAPY 1-16
- Dual-Sensor Blending 2-39
- Duration
  - ATR (atrial tachy response) 2-44
- Dynamic Noise Algorithm 2-25, 2-70

## E

- ECG (electrocardiogram)
  - display 1-3
  - surface 1-3
- EGM (electrogram)
  - display 1-3
  - real-time 1-3
- Electrocautery
  - mode 2-3
- Electrode, lead configuration 2-54
- End of ATR episode 2-45
- Entry count 2-44
- EP test (electrophysiologic test) 5-2
  - backup ventricular pacing during atrial stimulation 5-3
  - burst pacing, manual 5-5
  - induction 5-3
  - programmed electrical stimulation (PES) 5-3
- Episode
  - end of ATR 2-45
- Event
  - counter 4-10
  - icon 1-6
  - summary 4-5
  - therapy history 4-2
- Exit count 2-44

## F

- Fallback, atrial mode switch
  - LRL 2-45
  - mode 2-45
  - time 2-45
- Fitness Level 2-38
- Follow-up
  - Lead status 3-6

## H

- Heart rate variability (HRV) 4-11
- Histogram 4-9
- Hold
  - icon 1-6
- Horizontal slider
  - icon 1-6
- Hysteresis, rate 2-48

## I

- Icon
  - battery 1-5
  - check 1-5
  - continue 1-6
  - details 1-5
  - event 1-6
  - hold 1-6
  - horizontal slider 1-6
  - increment and decrement 1-6
  - information 1-6
  - lead 1-5
  - patient 1-5
  - patient information 1-18
  - POST Complete 1-6
  - Programmer/recorder/monitor (PRM) mode indicator 1-3
  - run 1-6
  - scrolling 1-7
  - snapshot 1-6
  - sorting 1-6
  - vertical slider 1-6
- Impedance test, lead 3-12
- Implant
  - post, information 4-18
- Increment and decrement
  - icon 1-6
- Indications Based Programming (IBP) 1-14
- Induction, EP test 5-3
- Information
  - icon 1-6
  - implant 1-18
  - lead 1-18

Boston Scientific Confidential. Unauthorized use is prohibited.

LIT APPROVAL - INGENIO 1-2 MRI REF GUIDE US

patient 1-18  
Interrogate 1-9  
Interval  
arrhythmia logbook 4-6  
Intrinsic amplitude test 3-12

## L

Lead  
configuration 2-54  
Daily measurements 3-6  
icon 1-5  
impedance 3-12  
intrinsic amplitude 3-12  
Lead status 3-6  
pace threshold 3-13  
test 3-11  
Lead Safety Switch 2-56  
Logbook 4-2  
Lower rate limit (LRL) 2-9

## M

Magnet  
feature setup 4-19  
rate 3-3  
Magnetic Resonance Imaging (MRI) 2-3  
Manual burst pacing 5-5  
Manual programming 1-16  
Maximum  
pacing rate 2-46  
sensor rate (MSR) 2-11  
tracking rate (MTR) 2-9  
Maximum pacing rate  
rate smoothing 2-51  
Memory, device 1-19  
Minute Ventilation 2-31  
fitness level 2-38  
response factor 2-36  
Ventilatory Threshold 2-36  
Ventilatory Threshold Response 2-36  
Mode  
Demonstration 1-8  
electrocautery 2-3  
fallback ATR (atrial tachy response) 2-45  
pacing 2-5  
Programmer/recorder/monitor (PRM) 1-3  
MRI Protection Mode 2-3

## N

Noise

Dynamic Noise Algorithm 2-25, 2-70  
response 2-69

## P

Pace  
STAT PACE 1-17  
Pace threshold test 3-13  
PaceSafe  
RAAT 2-13  
RVAC 2-17  
Pacing  
adaptive-rate 2-26  
amplitude 2-13  
ATR mode switch 2-43  
AV delay 2-57  
backup during atrial stimulation 5-3  
backup pacemaker in safety mode 1-20  
burst, manual 5-5  
Indications Based Programming (IBP) 1-14  
lower rate limit (LRL) 2-9  
maximum sensor rate (MSR) 2-11  
maximum tracking rate (MTR) 2-9  
mode 2-5  
noise response 2-69  
PaceSafe RAAT 2-13  
PaceSafe RVAC 2-17  
parameter, basic 2-5  
pulse width 2-12  
refractory 2-62  
runaway protection 2-12  
sensitivity 2-21  
sensor 2-40  
temporary 2-26  
therapy 2-2  
Package  
symbol on B-1  
Patient  
information icon 1-5  
Patient Information 1-18  
Patient triggered monitor 4-18  
PES (programmed electrical stimulation) 5-3  
PMT (pacemaker-mediated tachycardia)  
termination 2-47  
POST 3-11  
POST Complete  
icon 1-6  
Post implant information 4-18  
magnet feature 4-19  
Post-Operative  
System Test 3-11  
Premature ventricular contraction (PVC) 2-64  
Print  
report 1-19  
Printer  
external 1-19

Boston Scientific Confidential. Unauthorized use is prohibited.

LIT APPROVAL - INGENIO 1-2 MRI REF GUIDE US

- Program 1-14
- Programmer/recorder/monitor (PRM) 1-2
  - controls 1-2, 1-16
  - Demonstration mode 1-8
  - modes 1-3
  - software terminology 1-2
  - use of color 1-7
- Programming recommendation 1-14, 1-16
- Protection
  - runaway 2-12
- Pulse amplitude 2-13
- Pulse generator (PG)
  - memory 1-19
  - replacement indicators 3-4
- Pulse width 2-12
- PVARP (post ventricular atrial refractory period) 2-63
  - after PVC (premature ventricular contraction) 2-64
  - dynamic PVARP 2-63
- PVC (premature ventricular contraction) 2-64

## Q

- Quit
  - ending a telemetry session 1-10

## R

- RAAT (right atrial automatic threshold) 2-13
- Radio frequency (RF)
  - interference 1-12
  - operating temperature, telemetry 1-10, 1-12
  - starting telemetry 1-9
  - telemetry 1-8
- Rate
  - adaptive 2-26
  - lower limit (LRL) 2-9
  - magnet 3-3
  - maximum sensor 2-11
  - maximum tracking 2-9
- Rate adaptive pacing 2-26
- Rate enhancement, pacing
  - rate hysteresis 2-48
  - rate smoothing 2-49
- Rate Hysteresis 2-48
  - hysteresis offset 2-49
  - search hysteresis 2-49
- Rate smoothing 2-49
  - down 2-51
  - Maximum pacing rate 2-51
  - up 2-51
- Rate threshold, ATR 2-44
- Reaction time 2-29
- Read data 1-18
- Recovery time 2-30

- Red warning conditions 1-7
- Refractory
  - atrial, post ventricular (PVARP) 2-63
  - atrial, same chamber 2-65
  - blanking 2-66
  - PVARP after PVC 2-64
  - right ventricular (RVRP) 2-65
- Refractory; pacing
  - refractory 2-62
- Replacement Indicators 3-4
- Report, printed 1-3, 1-18
  - ECG/EGM 1-3
- Response factor, accelerometer 2-27
- Response Factor, Minute Ventilation 2-36
- Right ventricular refractory (RVRP) 2-65
- RightRate Pacing 2-31
- Run
  - icon 1-6
- Runaway protection 2-12
- RV-blank after A-pace 2-67
- RVAC (right ventricular automatic capture) 2-17
- RYTHMIQ 2-61

## S

- Safety core 1-19
- Safety mode 1-19
- Safety Switch 2-56
- Save data 1-18
- SBR 2-52
- Screen, programmer application 1-2
- Scrolling
  - icon 1-7
- Search +, AV 2-60
- Search AV Delay 2-60
- Search Interval 2-61
- Security
  - ZIP telemetry 1-10, 1-12
- Sensitivity 2-21
  - AGC (automatic gain control) 2-23
  - fixed sensing 2-25
  - unipolar sensing 2-22
- Sensor and trending, pacing 2-40
  - accelerometer 2-27
  - adaptive-rate 2-26
  - maximum sensor rate (MSR) 2-11
  - minute ventilation 2-31
- Snapshot 4-8
  - icon 1-6
- Software terminology 1-2
- Sorting
  - icon 1-6
- STAT PACE 1-17
- Stimulation, PES induction 5-3
- Stored EGM
  - arrhythmia logbook 4-5

Boston Scientific Confidential. Unauthorized use is prohibited.

LIT APPROVAL - INGENIO 1-2 MRI REF GUIDE US

Sudden brady response 2-52  
Symbol  
    on package B-1  
System Test  
    Post-Operative 3-11

Ventilatory Threshold Response 2-36  
Ventricular rate regulation 2-45  
    maximum pacing rate 2-46  
Ventricular Tachy EGM Storage 4-7  
Vertical slider  
    icon 1-6

## T

Tabs, software 1-5  
Telemetry  
    ending a telemetry session 1-10  
    operating temperature, ZIP 1-10, 1-12  
    starting ZIP 1-9  
    wand 1-8  
    wanded 1-9  
    ZIP 1-8  
Temporary  
    pacing 2-26  
Test  
    EP (electrophysiologic) 5-2  
    intrinsic amplitude 3-12  
    lead 3-11  
    lead impedance 3-12  
    pace threshold 3-13  
Therapy  
    pacing 2-2  
Therapy history 4-2  
    arrhythmia logbook 4-2  
    counter 4-10  
    heart rate variability (HRV) 4-11  
    histogram 4-9  
    patient triggered monitor 4-18  
Threshold, activity 2-28  
Timing  
    blinking 2-66  
    PVARP after PVC 2-64  
Timing, pacing 2-62  
Toolbar 1-4  
Trending  
    sensor 2-40  
Trends 4-14  
    minute ventilation sensor 4-16  
    respiratory rate 4-16

## U

Upper Rate Behavior 2-10  
USB 1-18

## V

Ventilatory Threshold 2-36

## W

Wand, telemetry 1-2, 1-8, 1-9  
Warning conditions, red 1-7  
Wenckebach 2-49

## Y

Yellow attention conditions 1-7

## Z

ZIP telemetry 1-8  
    advantages 1-9  
    indicator light 1-9  
    interference 1-12  
    operating temperature 1-10, 1-12  
    radio frequency (RF) 1-9  
    security 1-10, 1-12  
    session 1-9  
ZOOM LATITUDE Programming System  
    components 1-2  
ZOOMVIEW Software Application 1-2  
    purpose 1-2  
    screens and icons 1-2  
    use of color 1-7

Boston Scientific Confidential. Unauthorized use is prohibited.

**LIT APPROVAL - INGENIO 1-2 MRI REF GUIDE US**

Boston Scientific Confidential. Unauthorized use is prohibited.

**LIT APPROVAL - INGENIO 1-2 MRI REF GUIDE US**



Boston Scientific  
4100 Hamline Avenue North  
St. Paul, MN 55112-5798 USA

[www.bostonscientific.com](http://www.bostonscientific.com)

1.800.CARDIAC (227.3422)

+1.651.582.4000

© 2014 Boston Scientific Corporation or its affiliates.

All rights reserved.  
359239-001 EN US 2014-09

Boston Scientific Confidential. Unauthorized use is prohibited.

LIT APPROVAL - INGENIO 1-2 MRI REF GUIDE



Approved

1124976 A



**Boston  
Scientific**

PHYSICIAN'S LEAD MANUAL

# INGEVITY™ MRI

Pace/Sense Lead

IS-1 Bipolar Connector

Tined Fixation

Straight

Model 7731, 7732

Preformed Atrial J

Model 7735, 7736

**CAUTION:** Federal law (USA) restricts this device to sale by or on the order of a physician trained or experienced in device implant and follow-up procedures. Scientific Confidential. Unauthorized use is prohibited.

LIT APPROVAL-INGEVITY MRI PLM US models 7740-2/7731-2/7735-6

Approved

1104433 D

Boston Scientific Confidential. Unauthorized use is prohibited.

**LIT APPROVAL-INGEVITY MRI PLM US models 7740-2/7731-2/7735-6**

Approved

1104433 D

## Table of Contents

<b>INFORMATION FOR USE .....</b>	<b>1</b>
Device Description .....	1
Related Information .....	2
MR Conditional System Information .....	2
Indications and Usage.....	3
Contraindications .....	3
Warnings.....	3
Precautions .....	5
Potential Adverse Events.....	8
Warranty Information .....	10
<b>PRE- IMPLANT INFORMATION .....</b>	<b>10</b>
Surgical Preparation .....	10
Items Included.....	10
Accessories .....	10
Vein Pick.....	10
Radiopaque Suture Sleeve .....	10
Stylets .....	11
Lead Cap .....	11
<b>IMPLANTATION .....</b>	<b>12</b>
Inserting the Stylet .....	12
Inserting the Lead .....	13
Positioning Lead in Right Atrium.....	15
Positioning Lead in Right Ventricle.....	16
Checking for Lead Stability.....	17
Evaluating Lead Performance.....	18
Securing the Lead .....	19
Connection to a Pulse Generator.....	22
Electrical Performance .....	22
<b>POSTIMPLANT.....</b>	<b>23</b>
Postimplant Evaluation.....	23
Explantation.....	23
<b>SPECIFICATIONS .....</b>	<b>24</b>
Specifications (Nominal).....	24
Lead Introducer .....	26
Symbols on Packaging.....	26

Boston Scientific Confidential. Unauthorized use is prohibited.

**LIT APPROVAL-INGEVITY MRI PLM US models 7740-2/7731-2/7735-6**

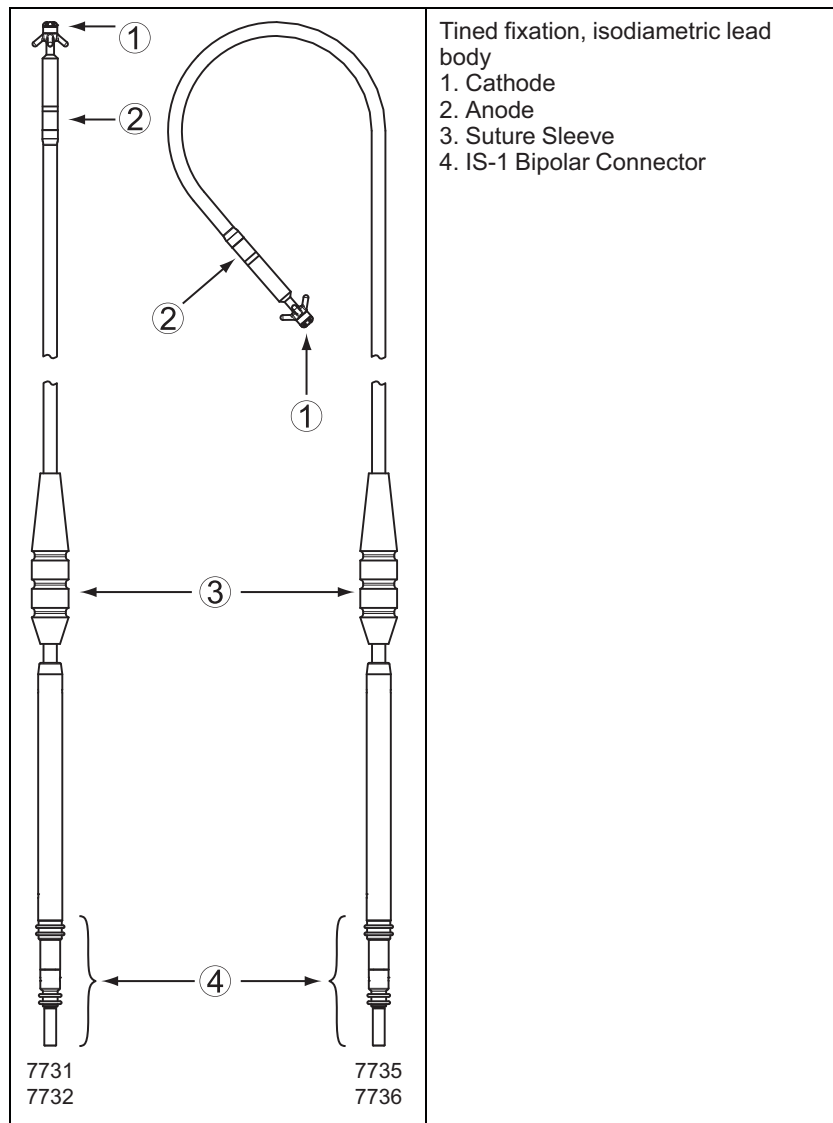

Boston Scientific Confidential. Unauthorized use is prohibited.  
 The following are trademarks of Boston Scientific or its affiliates: IMAGEREADY,  
 INGEVITY, IROX.

---

## INFORMATION FOR USE

### Device Description

This lead family has the following characteristics:

- Endocardial pace/sense lead—intended for chronic bipolar pacing and sensing in the atrium and/or ventricle.
- IS-1 bipolar connector<sup>1</sup>—the industry standard connector to be used in conjunction with a compatible cardiac device that accepts the IS-1 connector.
- MR Conditional—leads can be used as part of the ImageReady MR Conditional Pacing System when connected to Boston Scientific MR Conditional pulse generators ("MR Conditional System Information" on page 2).
- Tip electrode—serves as the cathode for intracardiac right atrial and/or right ventricular pacing/sensing, using a platinum-iridium design that increases the effective active area for sensing and increases chronic lead tip stability while maintaining a small surface area for pacing. The high impedance performance and low pacing thresholds may combine to increase the pacing longevity of the pulse generator.
- IROX-coated electrodes—the electrodes are coated with IROX to increase the microscopic surface area.
- Steroid-eluting—upon exposure to body fluids, the steroid elutes from the lead to help reduce tissue inflammation response at the distal electrode. The steroid suppresses the inflammatory response believed to cause threshold rises typically associated with implanted pacing electrodes. Lower thresholds are desirable because they can increase pacing safety margins and reduce pacing energy requirements, potentially increasing pulse generator longevity. The nominal dose and structure of the steroid are listed in the specifications (Table 5 Specifications (Nominal) on page 24).
- Radiopaque suture sleeve—the radiopaque suture sleeve is visible under fluoroscopy and is used to secure, immobilize, and protect the lead at the venous entry site after lead placement. The window feature is designed to aid compression of the sleeve onto the lead during suturing.
- Preformed Atrial J-shaped fixation—the distal portion of the preformed atrial J lead is anchored in position by removing the stylet and allowing the distal tip to assume a J shape that lodges in the atrial appendage.
- Tined—silicone rubber tines located proximal to the distal pacing electrode provide fixation in the atrial appendage (preformed atrial J) or in the apex of the right ventricle (straight).
- Fluoroscopic visibility—the platinum-iridium electrode design increases the visibility of the passive lead tip under fluoroscopy.

1. IS-1 refers to the international standard ISO 5841-3:2000.

- Lead body—the isodiametric lead body consists of a coaxial design that includes single-filar inner and outer coils designed for MR Conditional use in the MRI environment, as well as for improved flexural fatigue. The conductors are separated by both a silicone rubber and Polytetrafluoroethylene (PTFE) lining. Both the inner and outer coil are covered in Ethylene tetrafluoroethylene (ETFE) for extra insulation protection. The entire lead body is encompassed in a polyurethane outer insulation.
- Stylet delivery method—the design consists of an open-lumen conductor coil to enable lead delivery using a stylet. Refer to the stylet information ("Stylets" on page 11).

## Related Information

Instructions in the lead manual should be used in conjunction with other resource material, including the applicable pulse generator physician's manual and instructions for use on any implant accessories or tools.

Refer to the ImageReady MR Conditional Pacing System MRI Technical Guide (MRI Technical Guide) for information about MRI scanning.

Summaries of the relevant clinical studies supporting this product are available as separate documents. The following clinical summaries are approved as applicable to the leads described in this manual:

- INGEVITY
- SAMURAI

To view and download any of these documents, go to [www.bostonscientific-labeling.com](http://www.bostonscientific-labeling.com).

## INTENDED AUDIENCE

This literature is intended for use by professionals trained or experienced in device implant and/or follow-up procedures.

## MR Conditional System Information

These leads can be used as part of the ImageReady MR Conditional Pacing System when connected to Boston Scientific MR Conditional pulse generators. Patients with an MR Conditional Pacing System may be eligible to undergo MRI scans if performed when all Conditions of Use, as defined in the MRI Technical Guide, are met. Components required for MR Conditional status include specific models of Boston Scientific pulse generators, leads, and accessories; the Programmer/Recorder/Monitor (PRM); and PRM Software Application. For the model numbers of MR Conditional pulse generators and components, as well as a complete description of the ImageReady MR Conditional Pacing System, refer to the MRI Technical Guide.

## Lead Implant-related MRI Conditions of Use

The following MRI Conditions of Use pertain to leads. For a full list of Conditions of Use, refer to the MRI Technical Guide. All items on the full list of Conditions of Use must be met in order for an MRI scan to be considered MR Conditional.

- Patient is implanted with the ImageReady MR Conditional Pacing System<sup>2</sup>
- Bipolar pacing operation or pacing off
- Pulse generator implant location restricted to left or right pectoral region
- At least six (6) weeks have elapsed since implantation and/or any lead revision or surgical modification of the MR Conditional Pacing System
- No cardiac-related implanted devices, components, or accessories present other than the ImageReady MR Conditional Pacing System
- Pacing threshold < 2.0 V in pace-dependent patients
- No abandoned leads or pulse generators
- No evidence of a fractured lead or compromised pulse generator-lead system integrity

## Indications and Usage

This Boston Scientific lead is indicated for use as follows:

- Intended for chronic pacing and sensing in the right atrium (Preformed Atrial J) or right ventricle (Straight) when used with a compatible pulse generator

## Contraindications

Use of this Boston Scientific lead is contraindicated for the following patients:

- Patients with a hypersensitivity to a nominal single dose of 0.61 mg dexamethasone acetate
- Patients with mechanical tricuspid heart valves

## WARNINGS

### General

- **Labeling knowledge.** Read this manual thoroughly before implantation to avoid damage to the pulse generator and/or lead. Such damage can result in patient injury or death.
  - **For single patient use only.** Do not reuse, reprocess, or resterilize. Reuse, reprocessing, or resterilization may compromise the structural integrity of the device and/or lead to device failure which, in turn, may result in patient injury, illness, or death. Reuse, reprocessing, or resterilization may also create a risk of contamination of the device and/or cause patient infection or cross-infection, including, but not limited to, the transmission of infectious disease(s) from one patient to another. Contamination of the device may lead to injury, illness, or death of the patient.
  - **Backup defibrillation protection.** Always have external defibrillation equipment available during implant and electrophysiologic testing. If not
2. Defined as a Boston Scientific MR Conditional pulse generator and lead(s), with all ports occupied by a lead or port plug.

Boston Scientific Confidential. Unauthorized use is prohibited.

**LIT APPROVAL-INGEVITY MRI PLM US models 7740-2/7731-2/7735-6**

**3**

terminated in a timely fashion, an induced ventricular tachyarrhythmia can result in the patient's death.

- **Resuscitation availability.** Ensure that an external defibrillator and medical personnel skilled in CPR are present during post-implant device testing should the patient require external rescue.
- **Lead fracture.** Lead fracture, dislodgment, abrasion, or an incomplete connection can cause a periodic or continual loss of pacing or sensing or both.

### Handling

- **Excessive flexing.** Although pliable, the lead is not designed to tolerate excessive flexing, bending, or tension. This could cause structural weakness, conductor discontinuity, and/or lead dislodgment.
- **Do not kink leads.** Do not kink, twist, or braid the lead with other leads as doing so could cause lead insulation abrasion damage or conductor damage.

### Implant Related

- **Do not implant in MRI site Zone III.** Implant of the system cannot be performed in an MRI site Zone III (and higher) as defined by the American College of Radiology Guidance Document for Safe MR Practices<sup>3</sup>. Some of the accessories packaged with pulse generators and leads, including the torque wrench and stylet wires, are not MR Conditional and should not be brought into the MRI scanner room, the control room, or the MRI site Zone III or IV areas.
- **Obtain appropriate electrode position.** Take care to obtain appropriate electrode position. Failure to do so may result in suboptimal lead measurements.

### Post-Implant

- **Magnetic Resonance Imaging (MRI) exposure.** Unless all of the MRI Conditions of Use (as described in the MRI Technical Guide) are met, MRI scanning of the patient does not meet MR Conditional requirements for the implanted system, and significant harm to or death of the patient and/or damage to the implanted system may result.

Refer to the MRI Technical Guide for potential adverse events applicable when Conditions of Use are met or not met, as well as for a complete list of MRI-related Warnings and Precautions.

- **Diathermy.** Do not subject a patient with an implanted pulse generator and/or lead to diathermy since diathermy may cause fibrillation, burning of the myocardium, and irreversible damage to the pulse generator because of induced currents.

3. Kanal E, et al., American Journal of Roentgenology 188:1447-74, 2007.



## PRECAUTIONS

### Clinical Considerations

- **Dexamethasone acetate.** It has not been determined whether the warnings, precautions, or complications usually associated with injectable dexamethasone acetate apply to the use of a low concentration, highly localized, controlled-release device. Refer to the Physicians' Desk Reference<sup>® 4</sup> for a listing of potentially adverse effects.

### Sterilization and Storage

- **If package is damaged.** The blister trays and contents are sterilized with ethylene oxide gas before final packaging. When the pulse generator and/or lead is received, it is sterile provided the container is intact. If the packaging is wet, punctured, opened, or otherwise damaged, return the pulse generator and/or lead to Boston Scientific.
- **Storage temperature.** Store at 25°C (77°F). Excursions are permitted between 15°C to 30°C (59°F to 86°F) (see USP Controlled Room Temperature). Transportation spikes are permitted up to 50°C (122°F).
- **Use by date.** Implant the pulse generator and/or lead before or on the USE BY date on the package label because this date reflects a validated shelf life. For example, if the date is January 1, do not implant on or after January 2.

### Handling

- **Do not immerse in fluid.** Do not wipe or immerse the tip electrode in fluid. Such treatment will reduce the amount of steroid available when the lead is implanted.
- **Chronic repositioning.** Optimum threshold performance might not be achieved if the lead is chronically repositioned because the steroid can be depleted.
- **Protect from surface contamination.** The lead uses silicone rubber which can attract particulate matter, and therefore, must always be protected from surface contamination.
- **No mineral oil on lead tip.** Mineral oil should never come in contact with the lead tip electrode. Mineral oil on the tip may inhibit conduction.
- **Ensure suture sleeve position.** Ensure the suture sleeve remains proximal to the venous entry site and near the terminal boot molding throughout the procedure until it is time to secure the lead.

### Implantation

- **Evaluate patient for surgery.** There may be additional factors regarding the patient's overall health and medical condition that, while not related to device function or purpose, could render the patient a poor candidate for implantation of this system. Cardiac health advocacy groups may have published guidelines that may be helpful in conducting this evaluation.

4. Physicians' Desk Reference is a registered trademark of Thomson Healthcare Inc.

- **Lead compatibility.** Prior to implantation, confirm the lead-to-pulse generator compatibility. Using incompatible leads and pulse generators can damage the connector and/or result in potential adverse consequences, such as undersensing of cardiac activity or failure to deliver necessary therapy.
  - **Use recommended stylet.** It is recommended that you use a stylet designed for use with this lead.
  - **Line-powered equipment.** Exercise extreme caution if testing leads using line-powered equipment because leakage current exceeding 10  $\mu$ A can induce ventricular fibrillation. Ensure that any line-powered equipment is within specifications.
  - **Do not bend the lead near the lead-header interface.** Insert the lead terminal straight into the lead port. Do not bend the lead near the lead-header interface. Improper insertion can cause insulation or connector damage.
  - **Vein pick.** The vein pick is not intended either for puncturing the vein or for dissecting tissue during a cutdown procedure. Be sure that the vein pick does not puncture the insulation of the lead. This could prevent proper lead function.
  - **Do not bend lead with stylet in place.** Do not bend the lead with a stylet in place. Bending the lead could damage the conductor and insulation material.
  - **Tools applied to distal end.** Do not apply tools to the distal end of the lead because lead damage could occur. Avoid holding or handling the distal tip of the lead.
  - **Curving the stylet.** Do not use a sharp object to curve the distal end of a stylet. Do not curve a stylet while it is in the lead. If a curved stylet is preferred, gently curve a straight stylet before inserting it into the lead to avoid damage to the stylet and lead.
  - **Do not implant lead under clavicle.** When attempting to implant the lead via a subclavian puncture, do not introduce the lead under the medial one-third region of the clavicle. Damage or chronic dislodgment to the lead is possible if the lead is implanted in this manner. If implantation via the subclavian vein is desired, the lead must enter the subclavian vein near the lateral border of the first rib to avoid entrapment by the subclavius muscle or ligamentous structures associated with the narrow costoclavicular region. It has been established in the literature that lead fracture can be caused by lead entrapment in such soft tissue structures as the subclavius muscle, costocoracoid ligament, or the costoclavicular ligament.<sup>5</sup>
  - **Lead dislodgment.** Should dislodgment occur, immediate medical care is required to resolve the electrode position and minimize endocardial trauma.
5. Magney JE, et al. Anatomical mechanisms explaining damage to pacemaker leads, defibrillator leads, and failure of central venous catheters adjacent to the sternoclavicular joint. *PACE*. 1993;16:445–457.

- **Do not use tined lead if withdrawn through introducer.** Do not continue to use a tined lead if it has been withdrawn through an introducer, since damage to the tines may occur.
- **Compatible delivery tools.** Only use compatible delivery tools to deliver the lead because using incompatible delivery tools may cause lead damage or patient injury.
- **Avoid tight stricture.** When ligating the vein, avoid stricture that is too tight. A tight stricture might damage the insulation or sever the vein. Avoid dislodging the distal tip during the anchoring procedure.
- **Do not suture directly over lead.** Do not suture directly over the lead body, as this may cause structural damage. Use the suture sleeve to secure the lead proximal to the venous entry site to prevent lead movement.
- **Use caution to remove suture sleeve.** Avoid removing or cutting the suture sleeve from the lead. If removal of the suture sleeve is necessary, use caution as lead damage can occur.
- **Use of multiple suture sleeves has not been evaluated.** Use of multiple suture sleeves has not been evaluated and is not recommended.

### Hospital and Medical Environments

- **Electrocautery.** Electrocautery may induce ventricular arrhythmias and/or fibrillation, and may cause asynchronous pacing, inhibition of pacing, and/or a reduction in pulse generator pacing output possibly leading to loss of capture.

If electrocautery is medically necessary, observe the following to minimize risk to the lead. Also, refer to pulse generator labeling for device programming recommendations and additional information about minimizing risk to the patient and system.

- Avoid direct contact between the electrocautery equipment and the pulse generator or leads.
- Keep the path of the electrical current as far away as possible from the pulse generator and leads.
- If electrocautery is performed on tissue near the device or leads, monitor pre- and post- measurements for sensing and pacing thresholds and impedances to determine the integrity and stability of the system.
- Use short, intermittent, and irregular bursts at the lowest feasible energy levels.
- Use a bipolar electrocautery system where possible.
- **Radio frequency (RF) ablation.** RF ablation may induce ventricular arrhythmias and/or fibrillation, and may cause asynchronous pacing, inhibition of pacing, and/or a reduction in pulse generator pacing output possibly leading to loss of capture. RF ablation may also cause ventricular pacing up to the Maximum Tracking Rate (MTR) and/or changes in pacing

thresholds. Additionally, exercise caution when performing any other type of cardiac ablation procedure in patients with implanted devices.

If RF ablation is medically necessary, observe the following to minimize risk to the lead. Also, refer to pulse generator labeling for device programming recommendations and additional information about minimizing risk to the patient and system.

- Avoid direct contact between the ablation catheter and the pulse generator and leads. RF ablation close to the lead electrode may damage the lead-tissue interface.
- Keep the path of the electrical current as far away as possible from the pulse generator and leads.
- If RF ablation is performed on tissue near the device or leads, monitor pre- and post-measurements for sensing and pacing thresholds and impedances to determine the integrity and stability of the system.
- **Central line guidewire insertion.** Use caution when inserting guidewires for placement of other types of central venous catheter systems such as PIC lines or Hickman catheters in locations where pulse generator leads may be encountered. Insertion of such guidewires into veins containing leads could result in the leads being damaged or dislodged.

### Follow-up Testing

- **Lead performance in chronic state.** For some patients, lead performance at implant may not predict performance in the chronic state. Therefore, it is recommended that post-implant lead evaluation follow-up be done at the routine pulse generator follow-up and additionally as necessary.

### Potential Adverse Events

Based on the literature and on pulse generator and/or lead implant experience, the following alphabetical list includes the possible adverse events associated with implantation of products described in this literature:

- Air embolism
- Allergic reaction
- Arterial damage with subsequent stenosis
- Bleeding
- Bradycardia
- Breakage/failure of the implant instruments
- Cardiac perforation
- Cardiac tamponade
- Chronic nerve damage
- Component failure
- Conductor coil fracture
- Death

- Electrolyte imbalance/dehydration
- Elevated thresholds
- Erosion
- Excessive fibrotic tissue growth
- Extracardiac stimulation (muscle/nerve stimulation)
- Fluid accumulation
- Foreign body rejection phenomena
- Formation of hematomas or seromas
- Heart block
- Hemorrhage
- Hemothorax
- Inability to pace
- Inappropriate therapy (e.g., shocks and antitachycardia pacing [ATP] where applicable, pacing)
- Incisional pain
- Incomplete lead connection with pulse generator
- Infection including endocarditis
- Lead dislodgment
- Lead fracture
- Lead insulation breakage or abrasion
- Lead tip deformation and/or breakage
- Malignancy or skin burn due to fluoroscopic radiation
- Myocardial trauma (e.g., tissue damage, valve damage)
- Myopotential sensing
- Oversensing/undersensing
- Pericardial rub, effusion
- Pneumothorax
- Pulse generator and/or lead migration
- Syncope
- Tachyarrhythmias, which include acceleration of arrhythmias and early, recurrent atrial fibrillation
- Thrombosis/thromboemboli
- Valve damage
- Vasovagal response
- Venous occlusion
- Venous trauma (e.g., perforation, dissection, erosion)

For a list of potential adverse events associated with MRI scanning, refer to the MRI Technical Guide.

## Warranty Information

A limited warranty certificate for the lead is available. For a copy, contact Boston Scientific using the information on the back cover.

---

## PRE- IMPLANT INFORMATION

Proper surgical procedures and techniques are the responsibility of the medical professional. The described implant procedures are furnished only for informational purposes. Each physician must apply the information in these instructions according to professional medical training and experience.

The lead is designed, sold, and intended for use only as indicated.

## Surgical Preparation

Consider the following prior to the implantation procedure:

- Instrumentation for cardiac monitoring, imaging (fluoroscopy), external defibrillation, and lead signal measurements must be available during implant.
- Always isolate the patient from potentially hazardous leakage current when using electrical instrumentation.
- Sterile duplicates of all implantable items should be available for use if accidental damage or contamination occurs.

## Items Included

The following items are packaged with the lead:

- Vein pick
- Stylets
- Stylet guide
- Literature

## Accessories

Separately packaged lead accessories are available in addition to those packaged with the lead.

### Vein Pick

The vein pick is a disposable plastic device designed to assist with insertion into a vein during a cutdown procedure.

### Radiopaque Suture Sleeve

The radiopaque suture sleeve is an adjustable, tubular reinforcement that is visible under fluoroscopy. It is positioned over the outer lead insulation and is

designed to secure and protect the lead at the venous entry site after lead placement. Using a suture sleeve reduces the possibility of structural damage caused by suturing directly over the lead body. To move the suture sleeve, gently pinch and slide it over the lead until it is in the desired position. The window feature is designed to aid compression of the sleeve onto the lead during suturing.

**NOTE:** A radiopaque suture sleeve is pre-loaded on the lead and is also available in a slit form as an accessory (Model 6402). The accessory slit suture sleeve is intended to be used as a replacement for the pre-loaded suture sleeve in the event of damage or loss.

**CAUTION:** Use of multiple suture sleeves has not been evaluated and is not recommended.

### Stylets

Stylets aid in positioning the lead. Ensure you use the length appropriate to the lead. Stylets of various degrees of stiffness are available depending on implant technique and patient anatomy.

**Table 1. Stylet lengths and stiffness**

Lead Model Number (Type)	Length (cm) (imprinted on cap of the stylet knob)	Recommended Stylet Model Number (Type)	Stylet Stiffness and Knob Color	Stylet Cap Color
7735 (Preformed Atrial J)	45	5012 (Long Tapered)	Soft = Green	White
		5003 (Straight)	X-Soft = Yellow	
7731 (Straight)	52	5013 (Long Tapered)	Soft = Green	Red
7736 (Preformed Atrial J)		5004 (Straight)	X-Soft = Yellow	
7732 (Straight)	59	5014 (Long Tapered)	Soft = Green	Yellow
		5005 (Straight)	X-Soft = Yellow	

**CAUTION:** It is recommended that you use a stylet designed for use with this lead.

### Lead Cap

The lead cap may be used to isolate or cap the lead terminal that is not inserted in the pulse generator. Place a suture around the lead cap groove to secure the lead cap to the lead terminal. Use an appropriate cap for lead.

---

## IMPLANTATION

**NOTE:** Select the appropriate lead length for a given patient. It is important to select a lead that is long enough to avoid any sharp angles or kinks and to allow for a gentle curve of excess lead in the pocket. Typically, a minimum of 5 to 10 cm of excess lead is sufficient to achieve this configuration in the pocket.

**NOTE:** Refer to the MRI Technical Guide for considerations affecting choice and implant of leads for use as part of an MR Conditional system. Use of Boston Scientific MR Conditional pulse generators and leads is required for an implanted system to be considered MR Conditional. Refer to the MRI Technical Guide for model numbers of pulse generators, leads, accessories, and other system components needed to satisfy the Conditions of Use for MR Conditional scanning.

**NOTE:** Other implanted devices or patient conditions may cause a patient to be ineligible for an MRI scan, independent of the status of the patient's ImageReady MR Conditional Pacing System.

### Inserting the Stylet

Follow the steps below to insert a stylet.

1. Remove any preinserted stylet before inserting a different one.
2. Select a stylet according to the function and to the preferred firmness. If desired, gently curve the stylet with any sterile, smooth-surfaced instrument (e.g., 10-cc or 12-cc syringe barrel) (Figure 1 Curve the stylet on page 12).

**CAUTION:** Do not use a sharp object to curve the distal end of a stylet. Do not curve a stylet while it is in the lead. If a curved stylet is preferred, gently curve a straight stylet before inserting it into the lead to avoid damage to the stylet and lead.

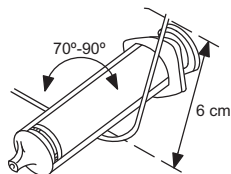

**Figure 1. Curve the stylet**

3. Insert the chosen stylet through the terminal pin or the stylet guide if using one (Figure 2 Insert the stylet on page 12).

**NOTE:** To optimize insertion into the lead, do not allow body fluids to come in contact with the stylet.

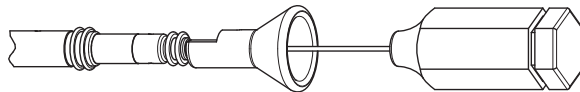

**Figure 2. Insert the stylet**



4. Ensure the stylet is fully inserted in the lead prior to inserting the lead into the vein.

**CAUTION:** Do not bend the lead with a stylet in place. Bending the lead could damage the conductor and insulation material.

## Inserting the Lead

The lead may be inserted using one of the following methods: via the cephalic vein, or through the subclavian or internal jugular vein.

- **Via cutdown through the left or right cephalic vein** Only one incision over the deltopectoral groove is required to access the right or left cephalic vein in the deltopectoral groove.

The vein pick packaged with this lead can be used to aid access during the cutdown procedure. Isolate the selected vein and introduce the point of the vein pick via this incision into the lumen of the vein. With the point of the vein pick facing in the direction of the desired lead passage, gently raise and tilt the pick. Pass the lead under the vein pick and into the vein.

**CAUTION:** The vein pick is not intended either for puncturing the vein or for dissecting tissue during a cutdown procedure. Be sure that the vein pick does not puncture the insulation of the lead. This could prevent proper lead function.



Figure 3. Using the vein pick

- **Percutaneously or via cutdown through the subclavian vein** A subclavian introducer set is available for use during percutaneous lead insertion. Refer to the specifications for the recommended introducer size.

**CAUTION:** When attempting to implant the lead via a subclavian puncture, do not introduce the lead under the medial one-third region of the clavicle. Damage or chronic dislodgment to the lead is possible if the lead is implanted in this manner. If implantation via the subclavian vein is desired, the lead must enter the subclavian vein near the lateral border of the first rib to avoid entrapment by the subclavius muscle or ligamentous structures associated with the narrow costoclavicular region. It has been established in the literature that lead fracture can be caused by lead entrapment in such soft tissue structures as the subclavius muscle, costocoracoid ligament, or the costoclavicular ligament.<sup>6</sup>

6. Magney JE, et al. Anatomical mechanisms explaining damage to pacemaker leads, defibrillator leads, and failure of central venous catheters adjacent to the sternoclavicular joint. *PACE*. 1993;16:445-457.

Leads placed by percutaneous subclavian venipuncture should enter the subclavian vein, where it passes over the first rib (rather than more medially), to avoid entrapment by the subclavius muscle or ligamentous structures associated with the narrow costoclavicular region.<sup>7</sup> It is recommended to introduce the lead into the subclavian vein near the lateral border of the first rib.

The syringe should be positioned directly above and parallel to the axillary vein to reduce the chance that the needle will contact the axillary or subclavian arteries or the brachial plexus. Use of fluoroscopy is helpful in locating the first rib and in guiding the needle.

The steps below explain how to identify the skin entry point and define the course of the needle toward the subclavian vein where it crosses the first rib.

1. Identify points St (sternal angle) and Cp (coracoid process) (Figure 4 Entry point for percutaneous subclavian venipuncture on page 14).

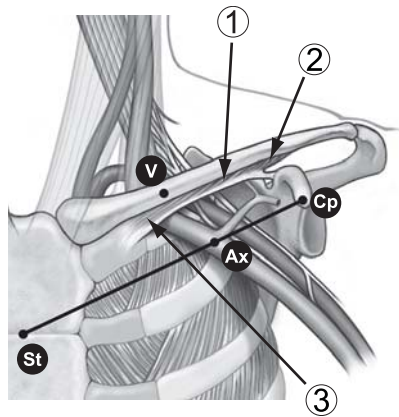

[1] Subclavius muscle [2] Costocoracoid ligament [3] Costoclavicular ligament

**Figure 4. Entry point for percutaneous subclavian venipuncture**

2. Visually draw a line between St and Cp, and divide the segment into thirds. The needle should pierce the skin at the junction of the middle and lateral thirds, directly above the axillary vein (point Ax).
3. Place an index finger on the clavicle at the junction of the medial and middle thirds (point V), beneath which point the subclavian vein should be located.
4. Press a thumb against the index finger and project 1–2 centimeters below the clavicle to shield the subclavius muscle from the needle (when hypertrophy of the pectoralis muscle is apparent, the thumb

7. Magney JE, et al. A new approach to percutaneous subclavian venipuncture to avoid lead fracture or central venous catheter occlusion. *PACE*. 1993;16:2133–2142.

should project about 2 centimeters below the clavicle because the subclavius muscle should be hypertrophied as well) (Figure 5 Location of thumb and needle entry on page 15).

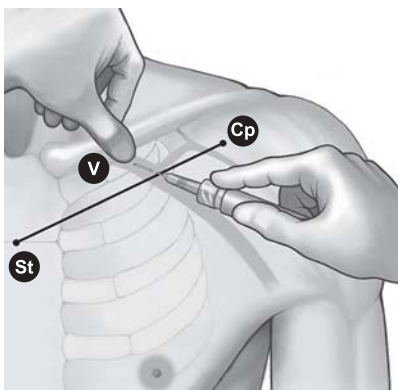

**Figure 5. Location of thumb and needle entry**

5. Feel with the thumb the pressure from the passage of the needle through the superficial fascia; direct the needle deep into the tissues toward the subclavian vein and the underlying first rib. Fluoroscopic guidance will reduce the chance that the needle would pass below the first rib and into the lung.

## Positioning Lead in Right Atrium

Correct functioning of the lead depends on appropriate placement of the electrodes. Follow the instructions below to position the lead.

1. Use a straight stylet to advance the lead into the right atrium.
2. Partially withdraw the stylet so that the distal end of the lead begins resuming the J shape.
3. To position the preformed atrial J lead, hold the stylet stationary and maintain fluoroscopic observation while advancing the lead tip until the tip enters and becomes lodged in the atrial appendage (Figure 6 Atrial placement on page 16).

**WARNING:** Take care to obtain appropriate electrode position. Failure to do so may result in suboptimal lead measurements.

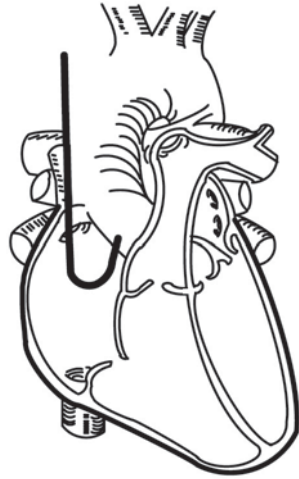

Figure 6. Atrial placement

### Positioning Lead in Right Ventricle

Correct functioning of the lead depends on appropriate placement of the electrodes. Follow the instructions below to position the lead.

1. Partially withdraw the stylet to utilize the flexible silicone neck during lead positioning. Withdrawal of the stylet tip proximal to the anode minimizes tip stiffness and provides added flexibility of the tip region.
2. Advance the lead into the right atrium using a straight stylet.
3. Advance the lead through the tricuspid valve or place the lead tip against the lateral atrial wall and back the curved lead body through the tricuspid valve.

**NOTE:** A curved stylet may enhance maneuverability.

4. Under fluoroscopy and with a stylet in the lead, advance the lead as far as possible until the tip enters and becomes lodged in healthy myocardium in the apex of the right ventricle.

**WARNING:** Take care to obtain appropriate electrode position. Failure to do so may result in suboptimal lead measurements.

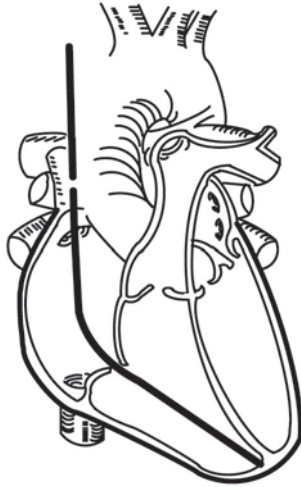

**Figure 7. Ventricular placement**

5. Verify under fluoroscopy that the distal tip electrode is situated in the right ventricle.

### **Checking for Lead Stability**

Follow these steps to check lead stability:

1. After fixation, partially withdraw the stylet 8 to 10 cm. (Also see step 5 in this list.)
2. Check the stability of the lead using fluoroscopy. Do not tug on the lead. If possible, have the patient cough or take several deep breaths.
3. For atrial implantation, after the lead tip is affixed to the heart wall, check for proper lead movement and lead slack in the atrium:
  - As the patient exhales, the lead J-shape should appear secure in the atrial appendage.
  - As the patient inhales, the J-shape straightens to form an L-shape. Sufficient slack is present if the lead assumes an L-shape. Excessive slack is present if the lead drops near the tricuspid valve.
4. For ventricular implantation, after the lead tip is affixed to the heart wall, check for proper lead movement and lead slack in the ventricle.
5. When the electrode position is satisfactory, withdraw the stylet.

**CAUTION:** Should dislodgment occur, immediate medical care is required to resolve the electrode position and minimize endocardial trauma.

**CAUTION:** Do not continue to use a tined lead if it has been withdrawn through an introducer, since damage to the tines may occur.

## Evaluating Lead Performance

Verify electrical performance of the lead using a pacing system analyzer (PSA) before attaching the lead to the pulse generator.

1. When the lead is placed in the desired location, partially withdraw the stylet so the terminal pin is accessible.
2. Connect the lead to the PSA.
  - For bipolar leads, the lead terminal pin is the cathode (–) conductor and should be connected to the negative conductor of the PSA patient cable. The ring of the lead terminal is the anode (+) conductor and should be connected to the positive conductor of the patient cable.
3. Perform the measurements as indicated in the table.

**Table 2. Recommended threshold and sensing measurements**

Measurements	Atrial Data	Ventricular Data
Voltage threshold (pulse width setting at 0.5 ms)	$\leq 1.5$ V	$\leq 1.0$ V
P-wave / R-wave	$\geq 2.0$ mV	$\geq 5.0$ mV
Impedance	200–2000 $\Omega$	200–2000 $\Omega$

- Pulse generator measurements may not exactly correlate to the PSA measurements due to signal filtering. Baseline measurements should fall within the recommended values indicated in the table.
  - Lower intrinsic potentials, longer durations, and higher pacing threshold may indicate lead placement in ischemic or scarred tissue. Because signal quality may deteriorate, reposition the lead if necessary to obtain a signal with the largest possible amplitude, shortest duration, and lowest pacing threshold.
4. If measurements do not conform to the values in the table, perform the following steps:
    - Remove the PSA from the lead.
    - Reinsert the stylet and reposition the lead using the procedures previously discussed and repeat the lead evaluation process.
    - If testing results are unsatisfactory, further lead system repositioning or replacement may be required.

**CAUTION:** Do not continue to use a tined lead if it has been withdrawn through an introducer, since damage to the tines may occur.

Consider the following information:

- Low stimulation threshold readings indicate a desirable safety margin, since stimulation threshold may rise after implantation.
- Initial electrical measurements may deviate from recommendations because of acute cellular trauma. If this occurs, wait approximately 10 minutes and repeat testing. Values may be dependent on patient-specific factors such as tissue condition, electrolyte balance, and drug interactions.

- Amplitude and duration measurements are not inclusive of current of injury and are taken during the patient's normal baseline rhythm.
5. Test for diaphragmatic stimulation by pacing the lead at a high voltage output, using professional medical judgment to select the output voltage. Adjust the lead configurations and lead position as necessary. PSA testing at higher outputs may also be considered to better characterize stimulation margins. Testing should be conducted for all lead placements.
  6. Once acceptable measurements are obtained, remove the pacing system analyzer connections, and remove the stylet.

## Securing the Lead

After the electrodes are satisfactorily positioned, use the suture sleeve to secure the lead to achieve permanent hemostasis and lead stabilization. Suture sleeve tie-down techniques can vary with the lead insertion technique used. Consider the following warning and precautions while securing the lead.

**WARNING:** Do not kink, twist, or braid the lead with other leads as doing so could cause lead insulation abrasion damage or conductor damage.

**CAUTION:** When ligating the vein, avoid stricture that is too tight. A tight stricture might damage the insulation or sever the vein. Avoid dislodging the distal tip during the anchoring procedure.

**CAUTION:** Do not suture directly over the lead body, as this may cause structural damage. Use the suture sleeve to secure the lead proximal to the venous entry site to prevent lead movement.

**CAUTION:** Avoid removing or cutting the suture sleeve from the lead. If removal of the suture sleeve is necessary, use caution as lead damage can occur.

**CAUTION:** Use of multiple suture sleeves has not been evaluated and is not recommended.

### **Percutaneous Implant Technique**

1. Peel back the introducer sheath and slide the suture sleeve deep into the tissue (Figure 8 Example of suture sleeve, percutaneous implant technique on page 20).

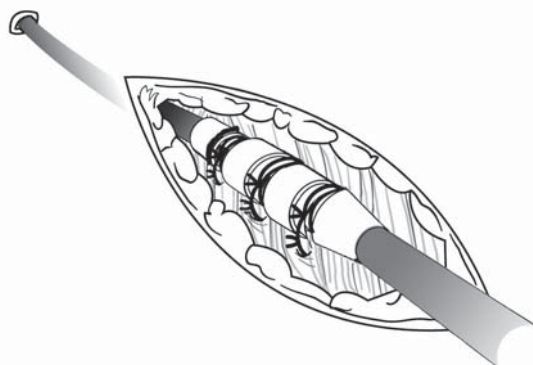

**Figure 8. Example of suture sleeve, percutaneous implant technique**



2. Using at least two grooves, ligate the suture sleeve and the lead to the fascia. For additional stability, the sleeve may be secured to the lead first before securing the sleeve to the fascia.
3. Check the suture sleeve after tie-down to demonstrate stability and lack of slippage by grasping the suture sleeve with fingers and trying to move the lead in either direction.

#### **Venous Cutdown Technique**

1. Slide the suture sleeve into the vein past the distal groove.
2. Ligate the vein around the suture sleeve to obtain hemostasis.
3. Using the same groove, secure the lead and vein to the adjacent fascia (Figure 9 Example of suture sleeve, venous cutdown technique on page 21).

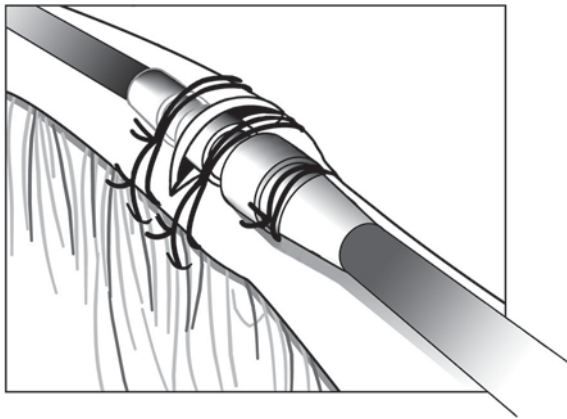

**Figure 9. Example of suture sleeve, venous cutdown technique**

4. Use at least two grooves to secure the sleeve to the lead. Secure the lead and suture sleeve to the adjacent fascia.
5. Check the suture sleeve after tie-down to demonstrate stability and lack of slippage by grasping the suture sleeve with fingers and trying to move the lead in either direction.

## Connection to a Pulse Generator

Consult the applicable pulse generator physician's manual for more instructions for connecting lead terminals to the pulse generator.

1. Verify the stylet and any terminal pin accessories are removed prior to connecting the lead to the pulse generator.
2. When the lead is secured at the venous entry site, recheck position and threshold measurements and then connect the lead to the pulse generator using the procedure described in the applicable pulse generator physician's manual.
3. Grasp the terminal immediately distal to the terminal ring contacts and fully insert the lead terminal into the pulse generator port until the terminal pin is visible beyond the setscrew block. If the terminal pin is difficult to insert, verify the setscrew is completely retracted.

**NOTE:** *If necessary, lubricate the lead connectors sparingly with sterile water to make insertion easier.*

4. Apply gentle traction to the lead by grasping the labeled area of the lead body to ensure a secure connection.

**CAUTION:** Insert the lead terminal straight into the lead port. Do not bend the lead near the lead-header interface. Improper insertion can cause insulation or connector damage.

**NOTE:** *If the lead terminal will not be connected to a pulse generator at the time of lead implantation, you must cap the connector before closing the pocket incision. The lead cap is designed specifically for this purpose. Place a suture around the lead cap to keep it in place.*

5. Giving consideration to patient anatomy and pulse generator size and motion, gently coil any excess lead and place adjacent to the pulse generator. It is important to place the lead into the pocket in a manner that minimizes lead tension, twisting, sharp angles, and/or pressure.

## Electrical Performance

1. Evaluate the lead signals using the pulse generator.
2. Place the pulse generator into the implant pocket as indicated in the pulse generator physician's manual. Also refer to the instructions in this manual ("Connection to a Pulse Generator" on page 22).
3. Evaluate the lead signals by viewing the real-time EGM. Consider the following:
  - The signal from the implanted lead should be continuous and without artifact, similar to a body-surface ECG.

- A discontinuous signal may indicate a lead fracture or an otherwise damaged lead, or an insulation break that would necessitate lead replacement.
  - Inadequate signals may result either in a failure of the pulse generator system to detect an arrhythmia or in an unnecessary delivery of therapy.
4. Test for diaphragmatic stimulation by pacing the lead at a high voltage output, using professional medical judgment to select the output voltage. Adjust the lead configurations and lead position as necessary. Testing should be conducted for all lead placements.

---

## POSTIMPLANT

### Postimplant Evaluation

Perform follow-up evaluation as recommended in the applicable pulse generator physician's manual.

**CAUTION:** For some patients, lead performance at implant may not predict performance in the chronic state. Therefore, it is recommended that post-implant lead evaluation follow-up be done at the routine pulse generator follow-up and additionally as necessary.

**WARNING:** Ensure that an external defibrillator and medical personnel skilled in CPR are present during post-implant device testing should the patient require external rescue.

**NOTE:** *Chronic repositioning of the lead may be difficult because of body fluid or fibrotic tissue intrusion.*

### Explantation

**NOTE:** *Return all explanted pulse generators and leads to Boston Scientific. Examination of explanted pulse generators and leads can provide information for continued improvement in system reliability and warranty considerations.*

**WARNING:** Do not reuse, reprocess, or resterilize. Reuse, reprocessing, or resterilization may compromise the structural integrity of the device and/or lead to device failure which, in turn, may result in patient injury, illness, or death. Reuse, reprocessing, or resterilization may also create a risk of contamination of the device and/or cause patient infection or cross-infection, including, but not limited to, the transmission of infectious disease(s) from one patient to another. Contamination of the device may lead to injury, illness, or death of the patient.

Contact Boston Scientific when any of the following occur:

- When a product is removed from service.
- In the event of patient death (regardless of cause), along with an autopsy report, if performed.
- For other observation or complications reasons.

**NOTE:** Disposal of explanted pulse generators and/or leads is subject to applicable laws and regulations. For a Returned Product Kit, contact Boston Scientific using the information on the back cover.

Consider the following items when explanting and returning the pulse generator and/or lead:

- Interrogate the pulse generator and print a comprehensive report.
- Deactivate the pulse generator before explantation.
- Disconnect the leads from the pulse generator.
- If leads are explanted, attempt to remove them intact, and return them regardless of condition. Do not remove leads with hemostats or any other clamping tool that may damage the leads. Resort to tools only if manual manipulation cannot free the lead.
- Wash, but do not submerge, the pulse generator and leads to remove body fluids and debris using a disinfectant solution. Do not allow fluids to enter the pulse generator's lead ports.
- Use a Boston Scientific Returned Product Kit to properly package the pulse generator and/or lead, and send it to Boston Scientific.

---

## SPECIFICATIONS

### Specifications (Nominal)

**Table 3. Model Number and Lead Length, Preformed Atrial J**

Model	Length (cm)
7735	45
7736	52

**Table 4. Model Number and Lead Length, Ventricular Straight**

Model	Length (cm)
7731	52
7732	59

**Table 5. Specifications (Nominal)**

Characteristic	Nominal
Terminal type	IS-1BI
Compatibility	Pulse generators with an IS-1 port, which accepts an IS-1 terminal
Fixation	Tined
Nominal Electrode Dimensions:	

**Table 5. Specifications (Nominal) (continued)**

Characteristic	Nominal
Tip surface area	5 mm <sup>2</sup>
Distance between electrodes	10.7 mm
Anode electrode	20 mm <sup>2</sup>
Nominal Diameter:	
Insertion	2.0 mm (6F)
Anode electrode	2.0 mm
Lead body	1.9 mm
Material:	
External insulation	Polyurethane (55D)
Internal insulation	Silicone rubber
Tine material	Silicone rubber
Terminal ring contact	316L stainless steel
IS-1 terminal pin contact	316L stainless steel
Tip electrode	IROX (iridium oxide) coated Pt-Ir
Anode electrode	IROX (iridium oxide) coated Pt-Ir
Conductor type	Single wound helical coils of MP35N™ a
Steroid	0.61 mg dexamethasone acetate
Suture sleeve	Radiopaque white silicone rubber
Maximum Lead Conductor Resistance:	
From terminal ring to anode (or ring) electrode	45 cm: 130 Ω 52 cm: 152 Ω 59 cm: 174 Ω
From terminal pin to tip electrode	45 cm: 180 Ω 52 cm: 209 Ω 59 cm: 238 Ω

a. MP35N is a trademark of SPS Technologies, Inc.

## Lead Introducer













**Table 6. Lead introducer**

Recommended lead introducer	
Introducer without guide wire	6F (2.0 mm)
Introducer with guide wire	9F (3.0 mm)



## Symbols on Packaging

The following symbols may be used on packaging and labeling (Table 7 Symbols on packaging on page 26):

**Table 7. Symbols on packaging**

Symbol	Description
	Reference number
	Serial number
	Use by
	Lot number
	Date of manufacture
	Sterilized using ethylene oxide
	Do not resterilize
	Do not reuse
	Do not use if package is damaged
	Consult instructions for use
	Opening instruction
	Authorized Representative in the European Community

**Table 7. Symbols on packaging (continued)**

Symbol	Description
	Manufacturer
	MR Conditional

Boston Scientific Confidential. Unauthorized use is prohibited.

**LIT APPROVAL-INGEVITY MRI PLM US models 7740-2/7731-2/7735-6**

Approved

1104433 D



Boston Scientific Confidential. Unauthorized use is prohibited.

**LIT APPROVAL-INGEVITY MRI PLM US models 7740-2/7731-2/7735-6**

Approved

1104433 D

Boston Scientific Confidential. Unauthorized use is prohibited.

**LIT APPROVAL-INGEVITY MRI PLM US models 7740-2/7731-2/7735-6**

Approved

1104433 D

Boston Scientific Confidential. Unauthorized use is prohibited.

**LIT APPROVAL-INGEVITY MRI PLM US models 7740-2/7731-2/7735-6**

Approved

1104433 D

# Boston Scientific

Boston Scientific  
4100 Hamline Avenue North  
St. Paul, MN 55112-5798 USA

[www.bostonscientific.com](http://www.bostonscientific.com)

1.800.CARDIAC (227.3422)

+1.651.582.4000

© 2014 Boston Scientific Corporation or its affiliates.

All rights reserved.  
358660-004 EN US 2014-12

Boston Scientific Confidential. Unauthorized



LIT APPROVAL-INGEVITY MRI PLM US models 7740-2/7731-2/7735-6

Approved

1104433 D

**Boston  
Scientific**

PHYSICIAN'S LEAD MANUAL

# INGEVITY™ MRI

Pace/Sense Lead

IS-1 Bipolar Connector

Extendable/Retractable Fixation

Straight

Model 7740, 7741, 7742

**CAUTION:** Federal law (USA) restricts this device to sale by or on the order of a physician trained or experienced in device implant and follow-up procedures. Scientific Confidential. Unauthorized use is prohibited.

LIT APPROVAL-INGEVITY MRI PLM US models 7740-2/7731-2/7735-6

Approved

1104433 D

Boston Scientific Confidential. Unauthorized use is prohibited.

**LIT APPROVAL-INGEVITY MRI PLM US models 7740-2/7731-2/7735-6**

Approved

1104433 D

## Table of Contents

<b>INFORMATION FOR USE .....</b>	<b>1</b>
Device Description .....	1
Related Information .....	2
MR Conditional System Information .....	2
Indications and Usage.....	3
Contraindications .....	3
Warnings.....	3
Precautions .....	5
Potential Adverse Events.....	9
Warranty Information .....	10
<b>PRE- IMPLANT INFORMATION .....</b>	<b>10</b>
Surgical Preparation .....	11
Items Included.....	11
Accessories .....	11
Vein Pick.....	11
Radiopaque Suture Sleeve .....	11
Stylets .....	12
Fixation Tool .....	12
Lead Cap .....	13
<b>IMPLANTATION .....</b>	<b>13</b>
Inserting the Stylet .....	13
Handling the Fixation Helix.....	14
Inserting the Lead .....	15
Positioning Lead in Right Atrium.....	18
Positioning Lead in Right Ventricle.....	19
Lead Fixation .....	20
Checking for Lead Stability.....	22
Repositioning the Lead.....	22
Evaluating Lead Performance.....	23
Securing the Lead .....	24
Connection to a Pulse Generator.....	27
Electrical Performance .....	27
<b>POSTIMPLANT.....</b>	<b>28</b>
Postimplant Evaluation.....	28
Explantation.....	28
<b>SPECIFICATIONS .....</b>	<b>29</b>
Specifications (Nominal).....	29
Lead Introducer .....	31
Symbols on Packaging.....	31

Boston Scientific Confidential. Unauthorized use is prohibited.

**LIT APPROVAL-INGEVITY MRI PLM US models 7740-2/7731-2/7735-6**

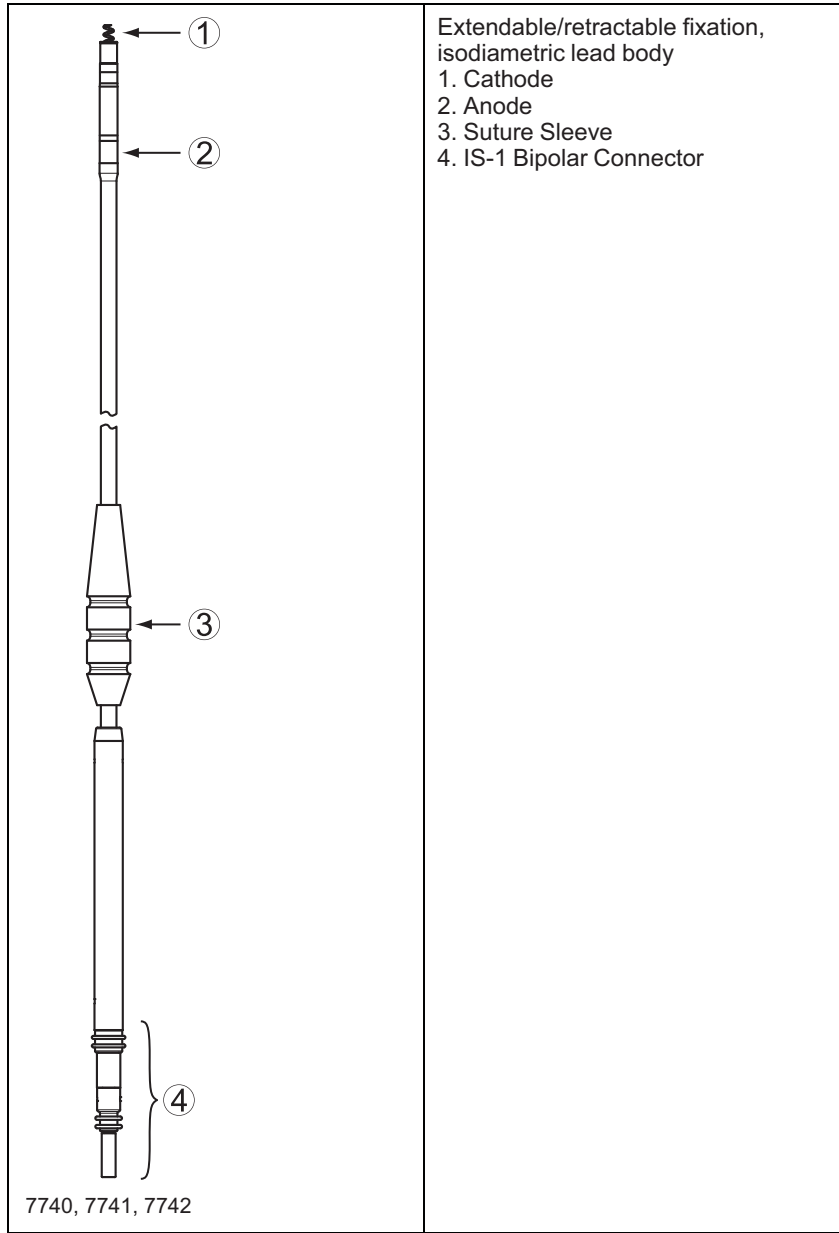

Extendable/retractable fixation,  
isodiametric lead body  
1. Cathode  
2. Anode  
3. Suture Sleeve  
4. IS-1 Bipolar Connector

Boston Scientific Confidential. Unauthorized use is prohibited.  
The following are trademarks of Boston Scientific or its affiliates: **IMAGEREADY**,  
**INGEVITY**, **INGEVITY MRI PLM US models 7740-2/7731-2/7735-6**  
**INGEVITY, IROX.**



---

## INFORMATION FOR USE

### Device Description

This lead family has the following characteristics:

- Endocardial pace/sense lead—intended for chronic bipolar pacing and sensing in the atrium and/or ventricle.
- IS-1 bipolar connector<sup>1</sup>—the industry standard connector to be used in conjunction with a compatible cardiac device that accepts the IS-1 connector.
- MR Conditional—leads can be used as part of the ImageReady MR Conditional Pacing System when connected to Boston Scientific MR Conditional pulse generators ("MR Conditional System Information" on page 2).
- IROX-coated electrodes—the electrodes are coated with IROX to increase the microscopic surface area.
- Steroid-eluting—upon exposure to body fluids, the steroid elutes from the lead to help reduce tissue inflammation response at the distal electrode. The steroid suppresses the inflammatory response believed to cause threshold rises typically associated with implanted pacing electrodes. Lower thresholds are desirable because they can increase pacing safety margins and reduce pacing energy requirements, potentially increasing pulse generator longevity. The nominal dose and structure of the steroid are listed in the specifications (Table 5 Specifications (Nominal) on page 29).
- Radiopaque suture sleeve—the radiopaque suture sleeve is visible under fluoroscopy and is used to secure, immobilize, and protect the lead at the venous entry site after lead placement. The window feature is designed to aid compression of the sleeve onto the lead during suturing.
- Extendable/Retractable fixation—the extendable/retractable helix design anchors the distal tip electrode to the endocardial surface without support of trabecular structures, offering various lead placement possibilities for the tip electrode in the right atrium and/or right ventricle. The helix serves as the cathode for endocardial pacing and sensing. The helix is extended and retracted using the fixation tool.
- Fluoroscopic markers—radiopaque markers near the distal tip can be seen under fluoroscopy. These markers show when the helix is fully retracted or fully extended.
- Lead body—the isodiametric lead body consists of a coaxial design that includes single-filar inner and outer coils designed for MR Conditional use in the MRI environment, as well as for improved flexural fatigue. The conductors are separated by both a silicone rubber and Polytetrafluoroethylene (PTFE) lining. Both the inner and outer coil are covered in Ethylene tetrafluoroethylene (ETFE) for extra insulation

1. IS-1 refers to the international standard ISO 5841-3:2000.

protection. The entire lead body is encompassed in a polyurethane outer insulation.

- Stilet delivery method—the design consists of an open-lumen conductor coil to enable lead delivery using a stilet. Refer to the stilet information ("Stilets" on page 12).

## Related Information

Instructions in the lead manual should be used in conjunction with other resource material, including the applicable pulse generator physician's manual and instructions for use on any implant accessories or tools.

Refer to the ImageReady MR Conditional Pacing System MRI Technical Guide (MRI Technical Guide) for information about MRI scanning.

Summaries of the relevant clinical studies supporting this product are available as separate documents. The following clinical summaries are approved as applicable to the leads described in this manual:

- INGEVITY
- SAMURAI

To view and download any of these documents, go to [www.bostonscientific-labeling.com](http://www.bostonscientific-labeling.com).

## INTENDED AUDIENCE

This literature is intended for use by professionals trained or experienced in device implant and/or follow-up procedures.

## MR Conditional System Information

These leads can be used as part of the ImageReady MR Conditional Pacing System when connected to Boston Scientific MR Conditional pulse generators. Patients with an MR Conditional Pacing System may be eligible to undergo MRI scans if performed when all Conditions of Use, as defined in the MRI Technical Guide, are met. Components required for MR Conditional status include specific models of Boston Scientific pulse generators, leads, and accessories; the Programmer/Recorder/Monitor (PRM); and PRM Software Application. For the model numbers of MR Conditional pulse generators and components, as well as a complete description of the ImageReady MR Conditional Pacing System, refer to the MRI Technical Guide.

### Lead Implant-related MRI Conditions of Use

The following MRI Conditions of Use pertain to leads. For a full list of Conditions of Use, refer to the MRI Technical Guide. All items on the full list of Conditions of Use must be met in order for an MRI scan to be considered MR Conditional.

- Patient is implanted with the ImageReady MR Conditional Pacing System<sup>2</sup>
- Bipolar pacing operation or pacing off

2. Defined as a Boston Scientific MR Conditional pulse generator and lead(s), with all ports occupied by a lead or port plug.

- Pulse generator implant location restricted to left or right pectoral region
- At least six (6) weeks have elapsed since implantation and/or any lead revision or surgical modification of the MR Conditional Pacing System
- No cardiac-related implanted devices, components, or accessories present other than the ImageReady MR Conditional Pacing System
- Pacing threshold < 2.0 V in pace-dependent patients
- No abandoned leads or pulse generators
- No evidence of a fractured lead or compromised pulse generator-lead system integrity

## Indications and Usage

This Boston Scientific lead is indicated for use as follows:

- Intended for chronic pacing and sensing in the right atrium and/or right ventricle when used with a compatible pulse generator

## Contraindications

Use of this Boston Scientific lead is contraindicated for the following patients:

- Patients with a hypersensitivity to a nominal single dose of 0.91 mg dexamethasone acetate
- Patients with mechanical tricuspid heart valves

## WARNINGS

### General

- **Labeling knowledge.** Read this manual thoroughly before implantation to avoid damage to the pulse generator and/or lead. Such damage can result in patient injury or death.
- **For single patient use only.** Do not reuse, reprocess, or resterilize. Reuse, reprocessing, or resterilization may compromise the structural integrity of the device and/or lead to device failure which, in turn, may result in patient injury, illness, or death. Reuse, reprocessing, or resterilization may also create a risk of contamination of the device and/or cause patient infection or cross-infection, including, but not limited to, the transmission of infectious disease(s) from one patient to another. Contamination of the device may lead to injury, illness, or death of the patient.
- **Backup defibrillation protection.** Always have external defibrillation equipment available during implant and electrophysiologic testing. If not terminated in a timely fashion, an induced ventricular tachyarrhythmia can result in the patient's death.
- **Resuscitation availability.** Ensure that an external defibrillator and medical personnel skilled in CPR are present during post-implant device testing should the patient require external rescue.

- **Lead fracture.** Lead fracture, dislodgment, abrasion, or an incomplete connection can cause a periodic or continual loss of pacing or sensing or both.

### Handling

- **Excessive flexing.** Although pliable, the lead is not designed to tolerate excessive flexing, bending, or tension. This could cause structural weakness, conductor discontinuity, and/or lead dislodgment.
- **Do not kink leads.** Do not kink, twist, or braid the lead with other leads as doing so could cause lead insulation abrasion damage or conductor damage.

### Implant Related

- **Do not implant in MRI site Zone III.** Implant of the system cannot be performed in an MRI site Zone III (and higher) as defined by the American College of Radiology Guidance Document for Safe MR Practices<sup>3</sup>. Some of the accessories packaged with pulse generators and leads, including the torque wrench and stylet wires, are not MR Conditional and should not be brought into the MRI scanner room, the control room, or the MRI site Zone III or IV areas.
- **Electrode placement above midseptum.** The safety and efficacy of the tip electrode placement in the right ventricle above midseptum has not been clinically established.
- **Obtain appropriate electrode position.** Take care to obtain appropriate electrode position. Failure to do so may result in suboptimal lead measurements.

### Post-Implant

- **Magnetic Resonance Imaging (MRI) exposure.** Unless all of the MRI Conditions of Use (as described in the MRI Technical Guide) are met, MRI scanning of the patient does not meet MR Conditional requirements for the implanted system, and significant harm to or death of the patient and/or damage to the implanted system may result.

Refer to the MRI Technical Guide for potential adverse events applicable when Conditions of Use are met or not met, as well as for a complete list of MRI-related Warnings and Precautions.

- **Diathermy.** Do not subject a patient with an implanted pulse generator and/or lead to diathermy since diathermy may cause fibrillation, burning of the myocardium, and irreversible damage to the pulse generator because of induced currents.

3. Kanal E, et al., American Journal of Roentgenology 188:1447-74, 2007.

4 Boston Scientific Confidential. Unauthorized use is prohibited.  
LIT APPROVAL-INGEVITY MRI PLM US models 7740-2/7731-2/7735-6

## PRECAUTIONS

### Clinical Considerations

- **Dexamethasone acetate.** It has not been determined whether the warnings, precautions, or complications usually associated with injectable dexamethasone acetate apply to the use of a low concentration, highly localized, controlled-release device. Refer to the Physicians' Desk Reference<sup>® 4</sup> for a listing of potentially adverse effects.

### Sterilization and Storage

- **If package is damaged.** The blister trays and contents are sterilized with ethylene oxide gas before final packaging. When the pulse generator and/or lead is received, it is sterile provided the container is intact. If the packaging is wet, punctured, opened, or otherwise damaged, return the pulse generator and/or lead to Boston Scientific.
- **Storage temperature.** Store at 25°C (77°F). Excursions are permitted between 15°C to 30°C (59°F to 86°F) (see USP Controlled Room Temperature). Transportation spikes are permitted up to 50°C (122°F).
- **Use by date.** Implant the pulse generator and/or lead before or on the USE BY date on the package label because this date reflects a validated shelf life. For example, if the date is January 1, do not implant on or after January 2.

### Handling

- **Do not immerse in fluid.** Do not wipe or immerse the tip electrode in fluid. Such treatment will reduce the amount of steroid available when the lead is implanted.
- **Chronic repositioning.** Optimum threshold performance might not be achieved if the lead is chronically repositioned because the steroid can be depleted.
- **Protect from surface contamination.** The lead uses silicone rubber which can attract particulate matter, and therefore, must always be protected from surface contamination.
- **Do not alter or use deformed helix.** To promote proper function do not use a lead with a deformed helix or damaged helix fixation mechanism. To avoid electrode damage, do not attempt to straighten or realign the helix. Avoid holding or handling the distal tip.
- **No mineral oil on lead tip.** Mineral oil should never come in contact with the helix. Mineral oil on the helix may inhibit tissue ingrowth and conduction.
- **Ensure suture sleeve position.** Ensure the suture sleeve remains proximal to the venous entry site and near the terminal boot molding throughout the procedure until it is time to secure the lead.

4. Physicians' Desk Reference is a registered trademark of Thomson Healthcare Inc.

## Implantation

- **Evaluate patient for surgery.** There may be additional factors regarding the patient's overall health and medical condition that, while not related to device function or purpose, could render the patient a poor candidate for implantation of this system. Cardiac health advocacy groups may have published guidelines that may be helpful in conducting this evaluation.
- **Lead compatibility.** Prior to implantation, confirm the lead-to-pulse generator compatibility. Using incompatible leads and pulse generators can damage the connector and/or result in potential adverse consequences, such as undersensing of cardiac activity or failure to deliver necessary therapy.
- **Use recommended stylet.** It is recommended that you use a stylet designed for use with this lead.
- **Line-powered equipment.** Exercise extreme caution if testing leads using line-powered equipment because leakage current exceeding 10  $\mu$ A can induce ventricular fibrillation. Ensure that any line-powered equipment is within specifications.
- **Do not bend the lead near the lead-header interface.** Insert the lead terminal straight into the lead port. Do not bend the lead near the lead-header interface. Improper insertion can cause insulation or connector damage.
- **Vein pick.** The vein pick is not intended either for puncturing the vein or for dissecting tissue during a cutdown procedure. Be sure that the vein pick does not puncture the insulation of the lead. This could prevent proper lead function.
- **Do not bend lead with stylet in place.** Do not bend the lead with a stylet in place. Bending the lead could damage the conductor and insulation material.
- **Tools applied to distal end.** Do not apply tools to the distal end of the lead because lead damage could occur. Avoid holding or handling the distal tip of the lead.
- **Curving the stylet.** Do not use a sharp object to curve the distal end of a stylet. Do not curve a stylet while it is in the lead. If a curved stylet is preferred, gently curve a straight stylet before inserting it into the lead to avoid damage to the stylet and lead.
- **Do not overextend or over-retract the helix.** Do not overextend or over-retract the helix. The lead can be damaged if you continue to rotate the terminal pin once the helix is fully extended or retracted.
- **Avoid creating sharp bends while extending or retracting helix.** Avoid creating sharp bends in the lead terminal or lead body while extending or retracting the helix.
- **Terminal pin maximum number of turns.** Do not rotate the terminal pin clockwise or counterclockwise more than the recommended maximum number of turns indicated in the specifications (Table 5 Specifications (Nominal) on page 29). Continuing to rotate the terminal pin once the helix

is fully extended or retracted (as indicated by fluoroscopy) can damage the lead, cause lead dislodgment, tissue trauma, and/or cause acute pacing threshold to rise.

- **Ensure helix is retracted.** Do not insert a lead into the vein when the helix is extended, as this may cause damage to the tissue and/or lead. Prior to insertion in the vein, rotate the terminal pin counterclockwise to retract the helix into the distal lead tip.
- **Helix retraction during implant.** Do not continue to use the lead if the helix cannot be retracted during implant. Continuous counterclockwise rotation of the lead body during lead removal is necessary to avoid inadvertent tissue trauma and accidental fixation, and to release the electrode helix if tissue snagging has occurred.
- **Do not implant lead under clavicle.** When attempting to implant the lead via a subclavian puncture, do not introduce the lead under the medial one-third region of the clavicle. Damage or chronic dislodgment to the lead is possible if the lead is implanted in this manner. If implantation via the subclavian vein is desired, the lead must enter the subclavian vein near the lateral border of the first rib to avoid entrapment by the subclavius muscle or ligamentous structures associated with the narrow costoclavicular region. It has been established in the literature that lead fracture can be caused by lead entrapment in such soft tissue structures as the subclavius muscle, costocoracoid ligament, or the costoclavicular ligament.<sup>5</sup>
- **Thin apical wall.** If the patient has a thin apical wall, another fixation site should be considered.
- **Lead dislodgment.** Should dislodgment occur, immediate medical care is required to resolve the electrode position and minimize endocardial trauma.
- **Prevent dislodgment.** To prevent dislodgment, avoid rotating the terminal pin after fixating the lead.
- **Compatible delivery tools.** Only use compatible delivery tools to deliver the lead because using incompatible delivery tools may cause lead damage or patient injury.
- **Avoid tight stricture.** When ligating the vein, avoid stricture that is too tight. A tight stricture might damage the insulation or sever the vein. Avoid dislodging the distal tip during the anchoring procedure.
- **Do not suture directly over lead.** Do not suture directly over the lead body, as this may cause structural damage. Use the suture sleeve to secure the lead proximal to the venous entry site to prevent lead movement.

5. Magney JE, et al. Anatomical mechanisms explaining damage to pacemaker leads, defibrillator leads, and failure of central venous catheters adjacent to the sternoclavicular joint. *PACE*. 1993;16:445–457.

- **Use caution to remove suture sleeve.** Avoid removing or cutting the suture sleeve from the lead. If removal of the suture sleeve is necessary, use caution as lead damage can occur.
- **Use of multiple suture sleeves has not been evaluated.** Use of multiple suture sleeves has not been evaluated and is not recommended.

### Hospital and Medical Environments

- **Electrocautery.** Electrocautery may induce ventricular arrhythmias and/or fibrillation, and may cause asynchronous pacing, inhibition of pacing, and/or a reduction in pulse generator pacing output possibly leading to loss of capture.

If electrocautery is medically necessary, observe the following to minimize risk to the lead. Also, refer to pulse generator labeling for device programming recommendations and additional information about minimizing risk to the patient and system.

- Avoid direct contact between the electrocautery equipment and the pulse generator or leads.
- Keep the path of the electrical current as far away as possible from the pulse generator and leads.
- If electrocautery is performed on tissue near the device or leads, monitor pre- and post- measurements for sensing and pacing thresholds and impedances to determine the integrity and stability of the system.
- Use short, intermittent, and irregular bursts at the lowest feasible energy levels.
- Use a bipolar electrocautery system where possible.
- **Radio frequency (RF) ablation.** RF ablation may induce ventricular arrhythmias and/or fibrillation, and may cause asynchronous pacing, inhibition of pacing, and/or a reduction in pulse generator pacing output possibly leading to loss of capture. RF ablation may also cause ventricular pacing up to the Maximum Tracking Rate (MTR) and/or changes in pacing thresholds. Additionally, exercise caution when performing any other type of cardiac ablation procedure in patients with implanted devices.

If RF ablation is medically necessary, observe the following to minimize risk to the lead. Also, refer to pulse generator labeling for device programming recommendations and additional information about minimizing risk to the patient and system.

- Avoid direct contact between the ablation catheter and the pulse generator and leads. RF ablation close to the lead electrode may damage the lead-tissue interface.
- Keep the path of the electrical current as far away as possible from the pulse generator and leads.
- If RF ablation is performed on tissue near the device or leads, monitor pre- and post-measurements for sensing and pacing thresholds and impedances to determine the integrity and stability of the system.



- **Central line guidewire insertion.** Use caution when inserting guidewires for placement of other types of central venous catheter systems such as PIC lines or Hickman catheters in locations where pulse generator leads may be encountered. Insertion of such guidewires into veins containing leads could result in the leads being damaged or dislodged.

### **Follow-up Testing**

- **Lead performance in chronic state.** For some patients, lead performance at implant may not predict performance in the chronic state. Therefore, it is recommended that post-implant lead evaluation follow-up be done at the routine pulse generator follow-up and additionally as necessary.

### **Potential Adverse Events**

Based on the literature and on pulse generator and/or lead implant experience, the following alphabetical list includes the possible adverse events associated with implantation of products described in this literature:

- Air embolism
- Allergic reaction
- Arterial damage with subsequent stenosis
- Bleeding
- Bradycardia
- Breakage/failure of the implant instruments
- Cardiac perforation
- Cardiac tamponade
- Chronic nerve damage
- Component failure
- Conductor coil fracture
- Death
- Electrolyte imbalance/dehydration
- Elevated thresholds
- Erosion
- Excessive fibrotic tissue growth
- Extracardiac stimulation (muscle/nerve stimulation)
- Fluid accumulation
- Foreign body rejection phenomena
- Formation of hematomas or seromas
- Heart block
- Hemorrhage
- Hemothorax

- Inability to pace
- Inappropriate therapy (e.g., shocks and antitachycardia pacing [ATP] where applicable, pacing)
- Incisional pain
- Incomplete lead connection with pulse generator
- Infection including endocarditis
- Lead dislodgment
- Lead fracture
- Lead insulation breakage or abrasion
- Lead tip deformation and/or breakage
- Malignancy or skin burn due to fluoroscopic radiation
- Myocardial trauma (e.g., tissue damage, valve damage)
- Myopotential sensing
- Oversensing/undersensing
- Pericardial rub, effusion
- Pneumothorax
- Pulse generator and/or lead migration
- Syncope
- Tachyarrhythmias, which include acceleration of arrhythmias and early, recurrent atrial fibrillation
- Thrombosis/thromboemboli
- Valve damage
- Vasovagal response
- Venous occlusion
- Venous trauma (e.g., perforation, dissection, erosion)

For a list of potential adverse events associated with MRI scanning, refer to the MRI Technical Guide.

## Warranty Information

A limited warranty certificate for the lead is available. For a copy, contact Boston Scientific using the information on the back cover.

---

## PRE- IMPLANT INFORMATION

Proper surgical procedures and techniques are the responsibility of the medical professional. The described implant procedures are furnished only for informational purposes. Each physician must apply the information in these instructions according to professional medical training and experience.

The lead is designed, sold, and intended for use only as indicated.

## Surgical Preparation

Consider the following prior to the implantation procedure:

- Instrumentation for cardiac monitoring, imaging (fluoroscopy), external defibrillation, and lead signal measurements must be available during implant.
- Always isolate the patient from potentially hazardous leakage current when using electrical instrumentation.
- Sterile duplicates of all implantable items should be available for use if accidental damage or contamination occurs.

## Items Included

The following items are packaged with the lead:

Vein pick  
Stylets  
Stylet guide  
Fixation tools  
Literature

## Accessories

Separately packaged lead accessories are available in addition to those packaged with the lead.

### Vein Pick

The vein pick is a disposable plastic device designed to assist with insertion into a vein during a cutdown procedure.

### Radiopaque Suture Sleeve

The radiopaque suture sleeve is an adjustable, tubular reinforcement that is visible under fluoroscopy. It is positioned over the outer lead insulation and is designed to secure and protect the lead at the venous entry site after lead placement. Using a suture sleeve reduces the possibility of structural damage caused by suturing directly over the lead body. To move the suture sleeve, gently pinch and slide it over the lead until it is in the desired position. The window feature is designed to aid compression of the sleeve onto the lead during suturing.

**NOTE:** A radiopaque suture sleeve is pre-loaded on the lead and is also available in a slit form as an accessory (Model 6402). The accessory slit suture sleeve is intended to be used as a replacement for the pre-loaded suture sleeve in the event of damage or loss.

**CAUTION:** Use of multiple suture sleeves has not been evaluated and is not recommended.

## Stylets

Stylets aid in positioning the lead. Ensure you use the length appropriate to the lead. Stylets of various degrees of stiffness are available depending on implant technique and patient anatomy.

**Table 1. Stylet lengths and stiffness**

Lead Model Number (Type)	Length (cm) (imprinted on cap of the stylet knob)	Recommended Stylet Model Number (Type)	Stylet Stiffness and Knob Color	Stylet Cap Color
7740 (Straight)	45	5012 (Long Tapered)	Soft = Green	White
		5003 (Straight)	X-Soft = Yellow	
		6053 (Wide Atrial J)	Soft = Green	
		6506 (Atrial J)	Soft = Green	
7741 (Straight)	52	5013 (Long Tapered)	Soft = Green	Red
		5004 (Straight)	X-Soft = Yellow	
		6054 (Wide Atrial J)	Soft = Green	
		6586 (Atrial J)	Soft = Green	
7742 (Straight)	59	5014 (Long Tapered)	Soft = Green	Yellow
		5005 (Straight)	X-Soft = Yellow	
		6055 (Wide Atrial J) <sup>a</sup>	Soft = Green	
		6603 (Atrial J) <sup>a</sup>	Soft = Green	

a. Stylet model available as accessory item only.

**CAUTION:** It is recommended that you use a stylet designed for use with this lead.

## Fixation Tool

The fixation tool can be attached to the terminal pin and rotated clockwise for extension or counterclockwise for retraction of the helix (Figure 1 Fixation tool on page 13).

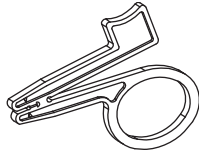

**Figure 1. Fixation tool**

### **Lead Cap**

The lead cap may be used to isolate or cap the lead terminal that is not inserted in the pulse generator. Place a suture around the lead cap groove to secure the lead cap to the lead terminal. Use an appropriate cap for lead.

---

## **IMPLANTATION**

**NOTE:** Select the appropriate lead length for a given patient. It is important to select a lead that is long enough to avoid any sharp angles or kinks and to allow for a gentle curve of excess lead in the pocket. Typically, a minimum of 5 to 10 cm of excess lead is sufficient to achieve this configuration in the pocket.

**NOTE:** Refer to the MRI Technical Guide for considerations affecting choice and implant of leads for use as part of an MR Conditional system. Use of Boston Scientific MR Conditional pulse generators and leads is required for an implanted system to be considered MR Conditional. Refer to the MRI Technical Guide for model numbers of pulse generators, leads, accessories, and other system components needed to satisfy the Conditions of Use for MR Conditional scanning.

**NOTE:** Other implanted devices or patient conditions may cause a patient to be ineligible for an MRI scan, independent of the status of the patient's ImageReady MR Conditional Pacing System.

### **Inserting the Stylet**

Follow the steps below to insert a stylet.

1. Remove any preinserted stylet before inserting a different one.
2. Select a stylet according to the function and to the preferred firmness. If desired, gently curve the stylet with any sterile, smooth-surfaced instrument (e.g., 10-cc or 12-cc syringe barrel) (Figure 2 Curve the stylet on page 14).

**CAUTION:** Do not use a sharp object to curve the distal end of a stylet. Do not curve a stylet while it is in the lead. If a curved stylet is preferred, gently curve a straight stylet before inserting it into the lead to avoid damage to the stylet and lead.

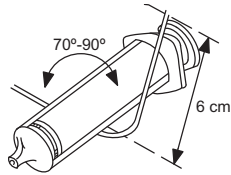

**Figure 2. Curve the stylet**

3. Insert the chosen stylet through the terminal pin or the stylet guide if using one (Figure 3 Insert the stylet on page 14).

**NOTE:** To optimize insertion into the lead, do not allow body fluids to come in contact with the stylet.

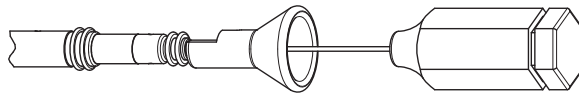

**Figure 3. Insert the stylet**

4. Ensure the stylet is fully inserted in the lead prior to inserting the lead into the vein.

**CAUTION:** Do not bend the lead with a stylet in place. Bending the lead could damage the conductor and insulation material.

## Handling the Fixation Helix

Before implanting the lead, verify the mechanical functioning of the lead.

1. Grasp the fixation tool and lead terminal. To engage the fixation tool, press the handles together and place the pin of the lead in the preformed groove. Release the tension on the handles to secure the terminal pin in the fixation tool.

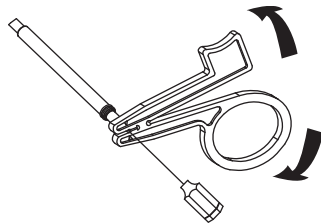

**Figure 4. Fixation tool attached**

2. Slowly rotate the terminal pin clockwise (approximately 1 rotation per second) to extend the helix and counterclockwise to retract it and visually observe the helix extending and retracting.

**NOTE:** The expected and the recommended maximum number of turns to extend or retract the helix are provided in the specifications (Table 5 Specifications (Nominal) on page 29). Any curves introduced into the stylet could increase the number of turns needed to extend or retract the helix.

**CAUTION:** Do not overextend or over-retract the helix. The lead can be damaged if you continue to rotate the terminal pin once the helix is fully extended or retracted.

**CAUTION:** If the helix cannot be extended or retracted, do not use the lead.

**CAUTION:** To promote proper function do not use a lead with a deformed helix or damaged helix fixation mechanism. To avoid electrode damage, do not attempt to straighten or realign the helix. Avoid holding or handling the distal tip.

**CAUTION:** Avoid creating sharp bends in the lead terminal or lead body while extending or retracting the helix.

3. Ensure the helix is retracted into the distal lead tip prior to inserting the lead into the vein.

**CAUTION:** Do not insert a lead into the vein when the helix is extended, as this may cause damage to the tissue and/or lead. Prior to insertion in the vein, rotate the terminal pin counterclockwise to retract the helix into the distal lead tip.

4. Disengage the fixation tool from the terminal pin prior to inserting the lead into the vein.

## Inserting the Lead

The lead may be inserted using one of the following methods: via the cephalic vein, or through the subclavian or internal jugular vein.

- **Via cutdown through the left or right cephalic vein** Only one incision over the deltopectoral groove is required to access the right or left cephalic vein in the deltopectoral groove.

The vein pick packaged with this lead can be used to aid access during the cutdown procedure. Isolate the selected vein and introduce the point of the vein pick via this incision into the lumen of the vein. With the point of the vein pick facing in the direction of the desired lead passage, gently raise and tilt the pick. Pass the lead under the vein pick and into the vein.

**CAUTION:** The vein pick is not intended either for puncturing the vein or for dissecting tissue during a cutdown procedure. Be sure that the vein pick does not puncture the insulation of the lead. This could prevent proper lead function.



Figure 5. Using the vein pick

- **Percutaneously or via cutdown through the subclavian vein** A subclavian introducer set is available for use during percutaneous lead insertion. Refer to the specifications for the recommended introducer size.

**CAUTION:** When attempting to implant the lead via a subclavian puncture, do not introduce the lead under the medial one-third region of the clavicle. Damage or chronic dislodgment to the lead is possible if the lead is implanted in this manner. If implantation via the subclavian vein is desired, the lead must enter the subclavian vein near the lateral border of the first rib to avoid entrapment by the subclavius muscle or ligamentous structures associated with the narrow costoclavicular region. It has been established in the literature that lead fracture can be caused by lead entrapment in such soft tissue structures as the subclavius muscle, costocoracoid ligament, or the costoclavicular ligament.<sup>6</sup>

Leads placed by percutaneous subclavian venipuncture should enter the subclavian vein, where it passes over the first rib (rather than more medially), to avoid entrapment by the subclavius muscle or ligamentous structures associated with the narrow costoclavicular region.<sup>7</sup> It is recommended to introduce the lead into the subclavian vein near the lateral border of the first rib.

The syringe should be positioned directly above and parallel to the axillary vein to reduce the chance that the needle will contact the axillary or subclavian arteries or the brachial plexus. Use of fluoroscopy is helpful in locating the first rib and in guiding the needle.

The steps below explain how to identify the skin entry point and define the course of the needle toward the subclavian vein where it crosses the first rib.

1. Identify points St (sternal angle) and Cp (coracoid process) (Figure 6 Entry point for percutaneous subclavian venipuncture on page 17).

6. Magney JE, et al. Anatomical mechanisms explaining damage to pacemaker leads, defibrillator leads, and failure of central venous catheters adjacent to the sternoclavicular joint. *PACE*. 1993;16:445–457.

7. Magney JE, et al. A new approach to percutaneous subclavian venipuncture to avoid lead fracture or central venous catheter occlusion. *PACE*. 1993;16:2133–2142.



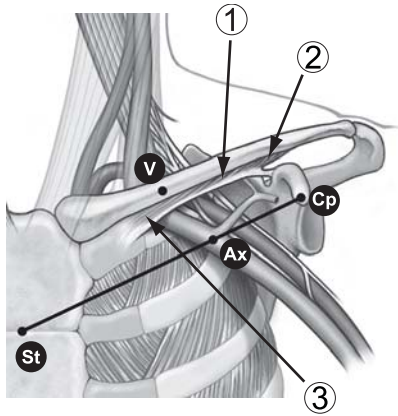

[1] Subclavius muscle [2] Costocoracoid ligament [3] Costoclavicular ligament

**Figure 6. Entry point for percutaneous subclavian venipuncture**

2. Visually draw a line between St and Cp, and divide the segment into thirds. The needle should pierce the skin at the junction of the middle and lateral thirds, directly above the axillary vein (point Ax).
3. Place an index finger on the clavicle at the junction of the medial and middle thirds (point V), beneath which point the subclavian vein should be located.
4. Press a thumb against the index finger and project 1–2 centimeters below the clavicle to shield the subclavius muscle from the needle (when hypertrophy of the pectoralis muscle is apparent, the thumb should project about 2 centimeters below the clavicle because the subclavius muscle should be hypertrophied as well) (Figure 7 Location of thumb and needle entry on page 17).

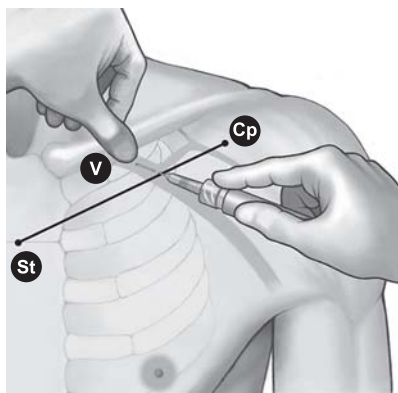

**Figure 7. Location of thumb and needle entry**

5. Feel with the thumb the pressure from the passage of the needle through the superficial fascia; direct the needle deep into the tissues toward the subclavian vein and the underlying first rib. Fluoroscopic guidance will reduce the chance that the needle would pass below the first rib and into the lung.

## Positioning Lead in Right Atrium

Two different J-shape stylets are provided. One has a longer reach and may be suitable for most patient anatomies. The smaller stylet may be more suitable for a patient with a smaller atrium or a patient who has had previous cardiac surgery.

Correct functioning of the lead depends on appropriate placement of the electrodes. Follow the instructions below to position the lead.

1. Ensure the helix is retracted.

**CAUTION:** Do not insert a lead into the vein when the helix is extended, as this may cause damage to the tissue and/or lead. Prior to insertion in the vein, rotate the terminal pin counterclockwise to retract the helix into the distal lead tip.

2. Use a straight stylet to advance the lead into the right atrium.
3. With the lead low in the right atrium, withdraw the straight stylet and insert a J-shaped or a curved straight stylet.
4. Gently pull the lead/stylet combination at the venous entry site to ensure contact between the lead tip and the endocardium. A satisfactory position has the lead tip situated against the endocardium in the atrium (Figure 8 Atrial placement on page 19).
5. After placing the lead, extend the helix as described in the Lead Fixation section ("Lead Fixation" on page 20).

**WARNING:** Take care to obtain appropriate electrode position. Failure to do so may result in suboptimal lead measurements.

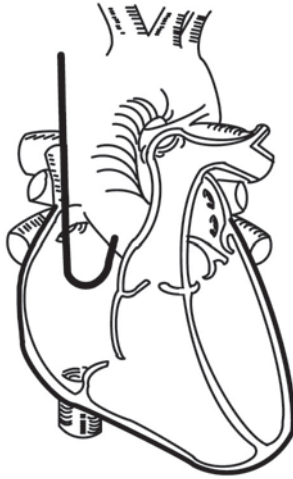

**Figure 8. Atrial placement**

### **Positioning Lead in Right Ventricle**

Correct functioning of the lead depends on appropriate placement of the electrodes. Follow the instructions below to position the lead.

1. Ensure the helix is retracted.

**CAUTION:** Do not insert a lead into the vein when the helix is extended, as this may cause damage to the tissue and/or lead. Prior to insertion in the vein, rotate the terminal pin counterclockwise to retract the helix into the distal lead tip.

2. Partially withdraw the stylet to utilize the flexible silicone neck during lead positioning. Withdrawal of the stylet tip proximal to the anode minimizes tip stiffness and provides added flexibility of the tip region.
3. Advance the lead into the right atrium using a straight stylet.
4. Advance the lead through the tricuspid valve or place the lead tip against the lateral atrial wall and back the curved lead body through the tricuspid valve.

**NOTE:** *A curved stylet may enhance maneuverability.*

5. Under fluoroscopy and with a stylet in the lead, advance the lead as far as possible so the tip electrode is in healthy myocardium in the apex of the right ventricle.

**WARNING:** Take care to obtain appropriate electrode position. Failure to do so may result in suboptimal lead measurements.

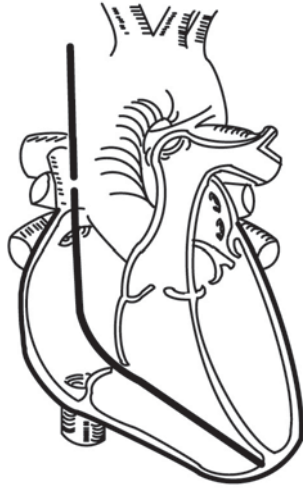

**Figure 9. Ventricular placement**

6. Verify under fluoroscopy that the distal tip electrode is situated in the right ventricle.

**CAUTION:** If the patient has a thin apical wall, another fixation site should be considered.

### **Lead Fixation**

The lead helix is electrically conductive to allow mapping (measuring pacing and sensing thresholds) of potential electrode positions without extending the helix into the tissue. Mapping prior to lead fixation is recommended as it can reduce the potential need for multiple lead positionings.

When data are acceptable and the correct position has been achieved, proceed with lead fixation.

**NOTE:** *Maintain the stylet in a partially retracted position when placing the lead in the RV apex or RV free wall to minimize tip stiffness.*

1. Attach the fixation tool to the terminal pin as indicated in the steps below.
  - a. Press the handles together and place the pin in the preformed groove.
  - b. Release the tension on the handles to secure the terminal pin in the fixation tool.

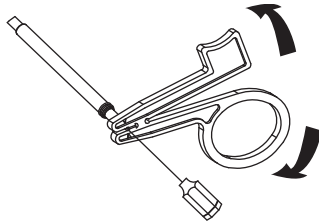

**Figure 10. Fixation tool attached**

2. Apply adequate pressure to the lead body to position the distal electrode against the desired fixation site.
3. Slowly rotate the fixation tool clockwise (approximately 1 rotation per second) to extend and affix the distal electrode helix into the heart wall.

**NOTE:** *Stylet curvature, extended implant time, and repositioning the lead multiple times may increase the number of turns to extend or retract the helix.*



**NOTE:** *The number of turns to extend or retract the helix may vary based on patient anatomy and implant conditions.*

**CAUTION:** Avoid creating sharp bends in the lead terminal or lead body while extending or retracting the helix.

**CAUTION:** Do not rotate the terminal pin clockwise or counterclockwise more than the recommended maximum number of turns indicated in the specifications (Table 5 Specifications (Nominal) on page 29). Continuing to rotate the terminal pin once the helix is fully extended or retracted (as indicated by fluoroscopy) can damage the lead, cause lead dislodgment, tissue trauma, and/or cause acute pacing threshold to rise.

4. View the radiopaque markers under fluoroscopy to identify when the fixation helix is fully extended. Full extension is achieved when the radiopaque markers are joined and the fixation helix is extended outside the distal fluoroscopy markers (Table 2 Fluoroscopic view of helix electrode on page 21).

**Table 2. Fluoroscopic view of helix electrode**

Fully Retracted	Fully Extended
	

5. Once the lead is affixed in the desired location, loosely hold the proximal end of the lead and remove the fixation tool from the terminal pin by pressing the handles together.

**NOTE:** *Upon release of the tool, minimal counter-rotation in the terminal pin may be observed.*

## Checking for Lead Stability

Follow these steps to check lead stability:

1. After fixation, partially withdraw the stylet 8 to 10 cm. (Also see step 5 in this list.)

**CAUTION:** To prevent dislodgment, avoid rotating the terminal pin after fixating the lead.

2. Check the stability of the lead using fluoroscopy. Do not tug on the lead. If possible, have the patient cough or take several deep breaths.
3. For atrial implantation, after the lead tip is affixed to the heart wall, check for proper lead movement and lead slack in the atrium:
  - As the patient exhales, the lead J-shape should appear secure in the atrial appendage.
  - As the patient inhales, the J-shape straightens to form an L-shape. Sufficient slack is present if the lead assumes an L-shape. Excessive slack is present if the lead drops near the tricuspid valve.
4. For ventricular implantation, after the lead tip is affixed to the heart wall, check for proper lead movement and lead slack in the ventricle.
5. When the electrode position is satisfactory, withdraw the stylet.

**CAUTION:** Should dislodgment occur, immediate medical care is required to resolve the electrode position and minimize endocardial trauma.

## Repositioning the Lead

If the lead needs repositioning, follow these steps.

1. Reconnect the fixation tool and rotate the tool counterclockwise to retract the helix.
2. View the radiopaque markers under fluoroscopy to verify that the helix is retracted and disengaged completely from the heart wall before attempting to reposition the lead.

**CAUTION:** Do not rotate the terminal pin clockwise or counterclockwise more than the recommended maximum number of turns indicated in the specifications (Table 5 Specifications (Nominal) on page 29). Continuing to rotate the terminal pin once the helix is fully extended or retracted (as indicated by fluoroscopy) can damage the lead, cause lead dislodgment, tissue trauma, and/or cause acute pacing threshold to rise.

**CAUTION:** Do not continue to use the lead if the helix cannot be retracted during implant. Continuous counterclockwise rotation of the lead body during lead removal is necessary to avoid inadvertent tissue trauma and accidental fixation, and to release the electrode helix if tissue snagging has occurred.

3. Reaffix the electrode using the previous procedures for handling, positioning, and checking for lead stability.

### Evaluating Lead Performance

Verify electrical performance of the lead using a pacing system analyzer (PSA) before attaching the lead to the pulse generator.

1. When the lead is placed in the desired location, partially withdraw the stylet so the terminal pin is accessible.
2. Connect the lead to the PSA.
  - For bipolar leads, the lead terminal pin is the cathode (–) conductor and should be connected to the negative conductor of the PSA patient cable. The ring of the lead terminal is the anode (+) conductor and should be connected to the positive conductor of the patient cable.
3. Perform the measurements as indicated in the table.

**Table 3. Recommended threshold and sensing measurements**

Measurements	Atrial Data	Ventricular Data
Voltage threshold (pulse width setting at 0.5 ms)	≤ 1.5 V	≤ 1.0 V
P-wave / R-wave	≥ 2.0 mV	≥ 5.0 mV
Impedance	200–2000 Ω	200–2000 Ω

- Pulse generator measurements may not exactly correlate to the PSA measurements due to signal filtering. Baseline measurements should fall within the recommended values indicated in the table.
  - Lower intrinsic potentials, longer durations, and higher pacing threshold may indicate lead placement in ischemic or scarred tissue. Because signal quality may deteriorate, reposition the lead if necessary to obtain a signal with the largest possible amplitude, shortest duration, and lowest pacing threshold.
4. If measurements do not conform to the values in the table, perform the following steps:
    - Remove the PSA from the lead.
    - Reinsert the stylet and reposition the lead using the procedures previously discussed and repeat the lead evaluation process.
    - If testing results are unsatisfactory, further lead system repositioning or replacement may be required.

Consider the following information:

- Low stimulation threshold readings indicate a desirable safety margin, since stimulation threshold may rise after implantation.
- Initial electrical measurements may deviate from recommendations because of acute cellular trauma. If this occurs, wait approximately 10 minutes and repeat testing. Values may be dependent on patient-

specific factors such as tissue condition, electrolyte balance, and drug interactions.

- Amplitude and duration measurements are not inclusive of current of injury and are taken during the patient's normal baseline rhythm.
  - Over-rotation of the terminal pin may increase local tissue trauma and cause temporarily high voltage thresholds.
5. Test for diaphragmatic stimulation by pacing the lead at a high voltage output, using professional medical judgment to select the output voltage. Adjust the lead configurations and lead position as necessary. PSA testing at higher outputs may also be considered to better characterize stimulation margins. Testing should be conducted for all lead placements.
  6. Once acceptable measurements are obtained, remove the pacing system analyzer connections, and remove the stylet.

## Securing the Lead

After the electrodes are satisfactorily positioned, use the suture sleeve to secure the lead to achieve permanent hemostasis and lead stabilization. Suture sleeve tie-down techniques can vary with the lead insertion technique used. Consider the following warning and precautions while securing the lead.

**WARNING:** Do not kink, twist, or braid the lead with other leads as doing so could cause lead insulation abrasion damage or conductor damage.

**CAUTION:** When ligating the vein, avoid stricture that is too tight. A tight stricture might damage the insulation or sever the vein. Avoid dislodging the distal tip during the anchoring procedure.

**CAUTION:** Do not suture directly over the lead body, as this may cause structural damage. Use the suture sleeve to secure the lead proximal to the venous entry site to prevent lead movement.

**CAUTION:** Avoid removing or cutting the suture sleeve from the lead. If removal of the suture sleeve is necessary, use caution as lead damage can occur.

**CAUTION:** Use of multiple suture sleeves has not been evaluated and is not recommended.



### **Percutaneous Implant Technique**

1. Peel back the introducer sheath and slide the suture sleeve deep into the tissue (Figure 11 Example of suture sleeve, percutaneous implant technique on page 25).

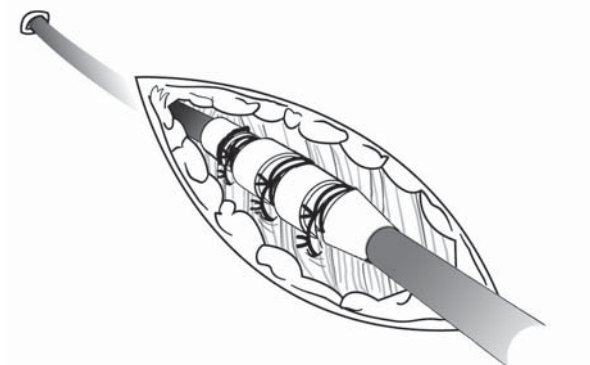
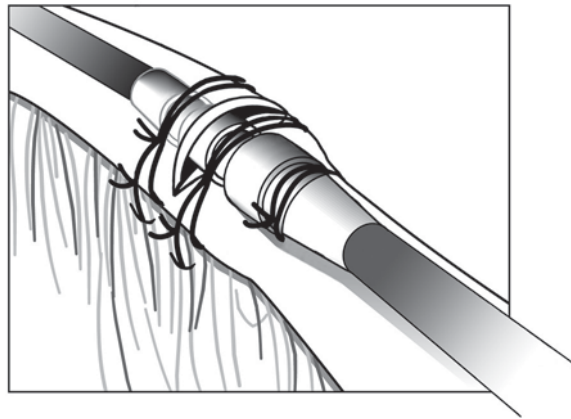

**Figure 11. Example of suture sleeve, percutaneous implant technique**

2. Using at least two grooves, ligate the suture sleeve and the lead to the fascia. For additional stability, the sleeve may be secured to the lead first before securing the sleeve to the fascia.
3. Check the suture sleeve after tie-down to demonstrate stability and lack of slippage by grasping the suture sleeve with fingers and trying to move the lead in either direction.

#### **Venous Cutdown Technique**

1. Slide the suture sleeve into the vein past the distal groove.
2. Ligate the vein around the suture sleeve to obtain hemostasis.
3. Using the same groove, secure the lead and vein to the adjacent fascia (Figure 12 Example of suture sleeve, venous cutdown technique on page 26).



**Figure 12. Example of suture sleeve, venous cutdown technique**

4. Use at least two grooves to secure the sleeve to the lead. Secure the lead and suture sleeve to the adjacent fascia.
5. Check the suture sleeve after tie-down to demonstrate stability and lack of slippage by grasping the suture sleeve with fingers and trying to move the lead in either direction.

## Connection to a Pulse Generator

Consult the applicable pulse generator physician's manual for more instructions for connecting lead terminals to the pulse generator.

1. Verify the stylet and any terminal pin accessories are removed prior to connecting the lead to the pulse generator.
2. When the lead is secured at the venous entry site, recheck position and threshold measurements and then connect the lead to the pulse generator using the procedure described in the applicable pulse generator physician's manual.
3. Grasp the terminal immediately distal to the terminal ring contacts and fully insert the lead terminal into the pulse generator port until the terminal pin is visible beyond the setscrew block. If the terminal pin is difficult to insert, verify the setscrew is completely retracted.

**NOTE:** *If necessary, lubricate the lead connectors sparingly with sterile water to make insertion easier.*

4. Apply gentle traction to the lead by grasping the labeled area of the lead body to ensure a secure connection.

**CAUTION:** Insert the lead terminal straight into the lead port. Do not bend the lead near the lead-header interface. Improper insertion can cause insulation or connector damage.

**NOTE:** *If the lead terminal will not be connected to a pulse generator at the time of lead implantation, you must cap the connector before closing the pocket incision. The lead cap is designed specifically for this purpose. Place a suture around the lead cap to keep it in place.*

5. Giving consideration to patient anatomy and pulse generator size and motion, gently coil any excess lead and place adjacent to the pulse generator. It is important to place the lead into the pocket in a manner that minimizes lead tension, twisting, sharp angles, and/or pressure.

## Electrical Performance

1. Evaluate the lead signals using the pulse generator.
2. Place the pulse generator into the implant pocket as indicated in the pulse generator physician's manual. Also refer to the instructions in this manual ("Connection to a Pulse Generator" on page 27).
3. Evaluate the lead signals by viewing the real-time EGM. Consider the following:
  - The signal from the implanted lead should be continuous and without artifact, similar to a body-surface ECG.

- A discontinuous signal may indicate a lead fracture or an otherwise damaged lead, or an insulation break that would necessitate lead replacement.
  - Inadequate signals may result either in a failure of the pulse generator system to detect an arrhythmia or in an unnecessary delivery of therapy.
4. Test for diaphragmatic stimulation by pacing the lead at a high voltage output, using professional medical judgment to select the output voltage. Adjust the lead configurations and lead position as necessary. Testing should be conducted for all lead placements.

---

## POSTIMPLANT

### Postimplant Evaluation

Perform follow-up evaluation as recommended in the applicable pulse generator physician's manual.

**CAUTION:** For some patients, lead performance at implant may not predict performance in the chronic state. Therefore, it is recommended that post-implant lead evaluation follow-up be done at the routine pulse generator follow-up and additionally as necessary.

**WARNING:** Ensure that an external defibrillator and medical personnel skilled in CPR are present during post-implant device testing should the patient require external rescue.

**NOTE:** *Chronic repositioning of the lead may be difficult because of body fluid or fibrotic tissue intrusion.*

### Explantation

**NOTE:** *Return all explanted pulse generators and leads to Boston Scientific. Examination of explanted pulse generators and leads can provide information for continued improvement in system reliability and warranty considerations.*

**WARNING:** Do not reuse, reprocess, or resterilize. Reuse, reprocessing, or resterilization may compromise the structural integrity of the device and/or lead to device failure which, in turn, may result in patient injury, illness, or death. Reuse, reprocessing, or resterilization may also create a risk of contamination of the device and/or cause patient infection or cross-infection, including, but not limited to, the transmission of infectious disease(s) from one patient to another. Contamination of the device may lead to injury, illness, or death of the patient.

Contact Boston Scientific when any of the following occur:

- When a product is removed from service.
- In the event of patient death (regardless of cause), along with an autopsy report, if performed.
- For other observation or complications reasons.

**NOTE:** Disposal of explanted pulse generators and/or leads is subject to applicable laws and regulations. For a Returned Product Kit, contact Boston Scientific using the information on the back cover.

Consider the following items when explanting and returning the pulse generator and/or lead:

- Interrogate the pulse generator and print a comprehensive report.
- Deactivate the pulse generator before explantation.
- Disconnect the leads from the pulse generator.
- If leads are explanted, attempt to remove them intact, and return them regardless of condition. Do not remove leads with hemostats or any other clamping tool that may damage the leads. Resort to tools only if manual manipulation cannot free the lead.
- Wash, but do not submerge, the pulse generator and leads to remove body fluids and debris using a disinfectant solution. Do not allow fluids to enter the pulse generator's lead ports.
- Use a Boston Scientific Returned Product Kit to properly package the pulse generator and/or lead, and send it to Boston Scientific.

---

## SPECIFICATIONS

### Specifications (Nominal)

**Table 4. Model Number and Lead Length**

Model	Length (cm)
7740	45
7741	52
7742	59

**Table 5. Specifications (Nominal)**

Characteristic	Nominal
Terminal type	IS-1BI
Compatibility	Pulse generators with an IS-1 port, which accepts an IS-1 terminal
Fixation	Extendable/retractable helix
Expected number of rotations (at approximately 1 rotation per second) to fully extend/retract the helix <sup>a</sup>	7 turns with straight stylet 8 turns with J stylet
Recommended maximum number of rotations to extend/retract the helix <sup>a</sup>	30 turns
Nominal fixation helix penetration depth	1.8 mm

**Table 5. Specifications (Nominal) (continued)**

Characteristic	Nominal
Tip to marker band distal edge	0.1 mm
Nominal Electrode Dimensions:	
Fixation helix surface area	4.5 mm <sup>2</sup>
Distance between electrodes	10.7 mm
Anode electrode	20 mm <sup>2</sup>
Nominal Diameter:	
Insertion	2.0 mm (6F)
Anode electrode	2.0 mm
Lead body	1.9 mm
Fixation helix	1.2 mm
Material:	
External insulation	Polyurethane (55D)
Internal insulation	Silicone rubber
Terminal ring contact	316L stainless steel
IS-1 terminal pin contact	316L stainless steel
Tip electrode	IROX (iridium oxide) coated Pt-Ir
Anode electrode	IROX (iridium oxide) coated Pt-Ir
Conductor type	Single wound helical coils of MP35N™ <sup>b</sup>
Steroid	0.91 mg dexamethasone acetate
Radiopaque markers	Pt-Ir
Suture sleeve	Radiopaque white silicone rubber
Maximum Lead Conductor Resistance:	
From terminal ring to anode (or ring) electrode	45 cm: 130 Ω 52 cm: 152 Ω 59 cm: 174 Ω
From terminal pin to tip electrode	45 cm: 180 Ω 52 cm: 209 Ω 59 cm: 238 Ω

- a. Use fluoroscopy markers for verification of full extension/retraction of the helix. The number of turns to extend or retract the helix may vary based on patient anatomy and implant conditions.
- b. MP35N is a trademark of SPS Technologies, Inc.

## Lead Introducer













**Table 6. Lead introducer**

Recommended lead introducer	
Introducer without guide wire	6F (2.0 mm)
Introducer with guide wire	9F (3.0 mm)



## Symbols on Packaging

The following symbols may be used on packaging and labeling (Table 7 Symbols on packaging on page 31):

**Table 7. Symbols on packaging**

Symbol	Description
	Reference number
	Serial number
	Use by
	Lot number
	Date of manufacture
	Sterilized using ethylene oxide
	Do not resterilize
	Do not reuse
	Do not use if package is damaged
	Consult instructions for use
	Opening instruction
	Authorized Representative in the European Community

**Table 7. Symbols on packaging (continued)**

Symbol	Description
	Manufacturer
	MR Conditional



Boston Scientific Confidential. Unauthorized use is prohibited.

**LIT APPROVAL-INGEVITY MRI PLM US models 7740-2/7731-2/7735-6**

Approved

1104433 D

Boston Scientific Confidential. Unauthorized use is prohibited.

**LIT APPROVAL-INGEVITY MRI PLM US models 7740-2/7731-2/7735-6**

Approved

1104433 D

Boston Scientific Confidential. Unauthorized use is prohibited.

**LIT APPROVAL-INGEVITY MRI PLM US models 7740-2/7731-2/7735-6**

Approved

1104433 D

# Boston Scientific

Boston Scientific  
4100 Hamline Avenue North  
St. Paul, MN 55112-5798 USA

[www.bostonscientific.com](http://www.bostonscientific.com)

1.800.CARDIAC (227.3422)

+1.651.582.4000

© 2014 Boston Scientific Corporation or its affiliates.

All rights reserved.  
358658-004 EN US 2014-12

Boston Scientific Confidential. Unauthorized



LIT APPROVAL-INGEVITY MRI PLM US models 7740-2/7731-2/7735-6

Approved

1104433 D



358690-001

**LEAD STYLETS**

Straight Lead Stylets, X-Soft

**Model** 5003 45 cm (0.013 in.)  
 5004 52 cm (0.013 in.)  
 5005 59 cm (0.013 in.)

Long Tapered Lead Stylets, Soft

**Model** 5012 45 cm (0.014 in.)  
 5013 52 cm (0.014 in.)  
 5014 59 cm (0.014 in.)

	Opening instructions
	Do not reuse
	Do not resterilize
	Do not use if package is damaged
	Sterilized using ethylene oxide
	Use by
	Date of manufacture
	Lot number
	Consult instructions for use
	Manufacturer

This literature is intended for use by professionals trained or experienced in device implant and/or follow-up procedures.

**WARNING:** For single patient use only. Do not reuse, reprocess, or resterilize. Reuse, reprocessing, or resterilization may compromise the structural integrity of the device and/or lead to device failure which, in turn, may result in patient injury, illness, or death. Reuse, reprocessing, or resterilization may also create a risk of contamination of the device and/or cause patient infection or cross-infection, including, but not limited to, the transmission of infectious disease(s) from one patient to another. Contamination of the device may lead to injury, illness, or death of the patient.

**STERILE**

Sterilized with ethylene oxide. Do not use if the package is open or damaged. Return the unused device to Boston Scientific. For single use only—do not resterilize devices.

**INTENDED USE**

For use with Boston Scientific implantable transvenous leads.

**INSTRUCTIONS FOR USE**

Insert a straight stylet into the lead lumen to direct lead passage and to position the lead in the appropriate heart chamber.

**CAUTION:**

- Do not use a sharp object to curve the distal end of a stylet.
- Do not curve a stylet while it is in the lead. If a curved stylet is preferred, gently curve a straight stylet before inserting it into the lead to avoid damage to the stylet and lead.

**Note:**

- Partially withdraw the stylet prior to evaluating lead performance.
- Verify the stylet is removed prior to connecting the lead to the pulse generator.

For further instructions, see the appropriate Physician's Lead Manual.

**WARRANTY DISCLAIMER**

Boston Scientific disclaims all express and implied warranties for this product, including without limitation any implied warranties of merchantability or fitness for a particular purpose. Buyer assumes all risk of loss or damages arising from use of this product.

**CAUTION:** Federal law restricts this device to sale by or on the order of a physician trained or experienced in device implant and follow-up procedures.



Boston Scientific  
4100 Hamline Avenue North  
St. Paul, MN 55112-5798 USA

1.800.CARDIAC (227.3422)  
+1.651.582.4000

[www.bostonscientific.com](http://www.bostonscientific.com)

© 2014 Boston Scientific Corporation or its affiliates.  
All Rights Reserved. EN US 2014-10

Boston Scientific Confidential. Unauthorized use is prohibited.  
**LIT APPROVAL Lead Stylets 5003-14 IFU - US**

Approved

1100571 C



## SUTURE SLEEVES

Model 6402

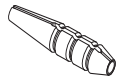

Contains two (2) suture sleeves, attachable

	Opening instructions
	Do not reuse
	Do not resterilize
	Do not use if package is damaged
	Sterilized using ethylene oxide
	Use by
	Date of manufacture
	Lot number
	Consult instructions for use
	Manufacturer

This literature is intended for use by professionals trained or experienced in device implant and/or follow-up procedures.

**WARNING:** For single patient use only. Do not reuse, reprocess, or resterilize. Reuse, reprocessing, or reesterilization may compromise the structural integrity of the device and/or lead to device failure which, in turn, may result in patient injury, illness, or death. Reuse, reprocessing, or reesterilization may also create a risk of contamination of the device and/or cause patient infection or cross-infection, including, but not limited to, the transmission of infectious disease(s) from one patient to another. Contamination of the device may lead to injury, illness, or death of the patient.

### STERILE

Sterilized with ethylene oxide. Do not use if the package is open or damaged. Return the unused device to Boston Scientific. For single use only—do not reesterilize devices.

### INTENDED USE

Use to secure and immobilize Boston Scientific INGEVITY™ leads at the venous entry site.

The suture sleeve is a radiopaque, adjustable, tubular reinforcement made of molded silicone rubber, used to secure and protect the lead at the venous entry site after placement. A slit traverses the length of the suture sleeve to facilitate installation over the INGEVITY lead body. Model 6402 also has a window feature, which is designed to aid compression of the sleeve onto the lead during suturing.

This accessory suture sleeve is intended to be used as a replacement for the pre-loaded suture sleeve in the event of damage or loss.

**CAUTION:** Use of multiple suture sleeves has not been evaluated and is not recommended.

### INSTRUCTIONS FOR USE

Fit the sleeve around the lead body, orienting the thin end towards the venous entry site. Move it along the lead until it has partially entered the vein. When the suture sleeve is in position, ligate the vein with nonabsorbable synthetic ligatures. To complete the procedure, suture the sleeve to the subcutaneous tissue.

**CAUTION:** When ligating the vein, avoid stricture that is too tight. A tight stricture might damage the insulation or sever the vein. Avoid dislodging the distal tip during the anchoring procedure.

For further instructions, see the appropriate Boston Scientific Physician's Lead Manual.

### WARRANTY DISCLAIMER

Boston Scientific disclaims all express and implied warranties for this product, including without limitation any implied warranties of merchantability or fitness for a particular purpose. Buyer assumes all risk of loss or damages arising from use of this product.

**CAUTION:** Federal law restricts this device to sale by or on the order of a physician trained or experienced in device implant and follow-up procedures.

INGEVITY is a trademark of Boston Scientific or its affiliates.

**Boston  
Scientific**

Boston Scientific  
4100 Hamline Avenue North  
St. Paul, MN 55112-5798 USA

1.800.CARDIAC (227.3422)  
+1.651.582.4000

[www.bostonscientific.com](http://www.bostonscientific.com)

© 2014 Boston Scientific Corporation or its affiliates.  
All Rights Reserved. EN US 2014-10

Boston Scientific Confidential. Unauthorized use is prohibited.  
**LIT APPROVAL-INGEVITY Suture Sleeve 6402 IFU - US**

Approved

1111134 C