



**XACT™**  
**Carotid Stent System**



**Unformatted version not intended for procurement, manufacturing  
or publishing on a website**

## Information for Prescribers

**CAUTION:** Federal (USA) law restricts this device to sale by or on the order of a physician.

**Limited to use by physicians or allied healthcare professionals under the direction of such physicians experienced in carotid stenting and who have received appropriate training in the use of the XACT™ Carotid Stent System. The XACT Carotid Stent System is indicated for use with the Emboshield™ Family of Embolic Protection System or ENROUTE<sup>‡</sup> Transcarotid Neuroprotection System.**

### Table of Contents

1.0	DEVICE DESCRIPTION	
		Figure 1: XACT RX Carotid Stent System
		Figure 2: Tapered Stent
		Figure 3: Straight Stent
		Table 1: Device Range
2.0	INDICATIONS	
3.0	CONTRAINDICATIONS	
4.0	WARNINGS	
5.0	PRECAUTIONS	
	5.1	MRI Information
6.0	ADVERSE EVENTS	
	6.1	Observed Adverse Events
		Table 2: Serious Adverse Events Summary, Up to 30 Days
		Table 3: Serious Adverse Events Summary, Up to 365 Days
		Table 4: Cause of Death (< 30 days, 31 – 365 days)
	6.2	Potential Adverse Effects
7.0	SYNOPSIS OF CLINICAL STUDY	
	7.1	SECURITY Registry Trial
		Table 5: Study Endpoints
		Table 6: SECURITY Patient Follow-up
		Table 7: Baseline Demographics
		Table 8: Non-Hierarchical Summary of Safety Measures in the SECURITY Trial
		Table 9: Summary of Efficacy Measures in the SECURITY Trial
		Table 10: Improvement in Target Lesion Lumen Diameter
		Figure 4: Freedom from Composite Endpoint of Stroke, Death and MI (0 – 365 days)
	7.2	EXACT Post-Approval Study
		Table 11: EXACT Patient Baseline Characteristics
		Table 12: EXACT Hierarchical Safety Events (≤ 30 days)
		Table 13: EXACT Non-Hierarchical Safety Events (≤ 30 days)

Figure 5: Kaplan Meier Curve – Freedom From DSMI (to 30 Days) or Ipsilateral Stroke (to 365 Days)

Figure 6: Kaplan Meier Curve – Freedom from Ipsilateral Stroke (31 to 365 Days)

Table 14: Device Success (N = 2,232)

Table 15: EXACT Hierarchical Safety Event Rates  $\leq$  30 days by Physician Training Level

### 7.3 PROTECT Post-Approval Study

Table 16: Baseline Demographics

Table 17: Summary of High Risk Inclusion Criteria

Table 18: Hierarchical Summary of Death, Stroke or MI Primary Endpoint Events  $\leq$  30 Days (Intent-to-Treat Population)

Table 19: Non-Hierarchical Summary of Death, Stroke or MI Primary Endpoint Events  $\leq$  30 Days (Intent-to-Treat Population)

Figure 7: Freedom From DSMI (to 30 Days) or Ipsilateral Stroke (31 Days to 3 Years) (Intent-to-Treat Population)

Figure 8: Freedom From Ipsilateral Stroke between 31 Days and 3 Years (Intent-to-Treat Population)

Figure 9: Freedom From DSMI (to 30 Days) or Ipsilateral Stroke (31 Days to 3 Years) (Intent-to-Treat Population)

Table 20: Acute Device Success and Procedure Success (Intent-to-Treat Population)

Table 21: Non-Hierarchical Subject Counts of TIA and Amaurosis Fugax Endpoint Events  $\leq$  30 Days (Intent-to Treat Population)

Figure 10: Freedom From Clinically Driven Target Lesion Revascularization within 3 Years (Intent-to-Treat Population)

### 7.4 XACT / ENROUTE NPS Project

Table 22: XACT TCAR Patient Baseline Characteristics (Per-Subject Analysis)

Table 23: XACT TCAR Patient Anatomical Characteristics (Per-Lesion Analysis)

Table 24: XACT TCAR Procedural Outcomes

Table 25: XACT TCAR Safety Outcomes (Per-Subject Analysis)

## 8.0 CLINICIAN USE INFORMATION

8.1 Materials Required

8.2 Periprocedural Care

8.3 Pre-Procedure

8.4 Stent Sizing

Table 26: Stent Sizing (Straight Stent)

Table 27: Stent Sizing (Tapered Stent)

8.5 Delivery System Preparation

Figure 11: Retracting the Tip

8.6 Introduction of the Stent Delivery System

8.7 Stent Deployment

Figure 12: Stent Deployment

- 8.8 Post-deployment Stent Dilatation
- 8.9 Post-Stent Placement
- 9.0 PATIENT COUNSELING AND PATIENT INFORMATION
- 10.0 HOW SUPPLIED
- 11.0 DISPOSAL

## 1.0 DEVICE DESCRIPTION

The XACT™ Carotid Stent System is comprised of a delivery system and a self-expanding stent. The delivery system is a rapid exchange (RX) system designed to deliver the self-expanding stent to the carotid vasculature.

The self-expanding stent is cut from a Nitinol tube into a flexible tubular prosthesis. Upon deployment of the stent into the carotid vasculature via the delivery system, the stent should appose the vessel wall and apply an outward pressure to establish patency. The XACT stent is available in tapered and straight configurations, with diameters ranging from 6 mm to 10 mm. Stent lengths range from 20 mm to 40 mm. For more details, see the stent size matrix in **Table 1** of this document.

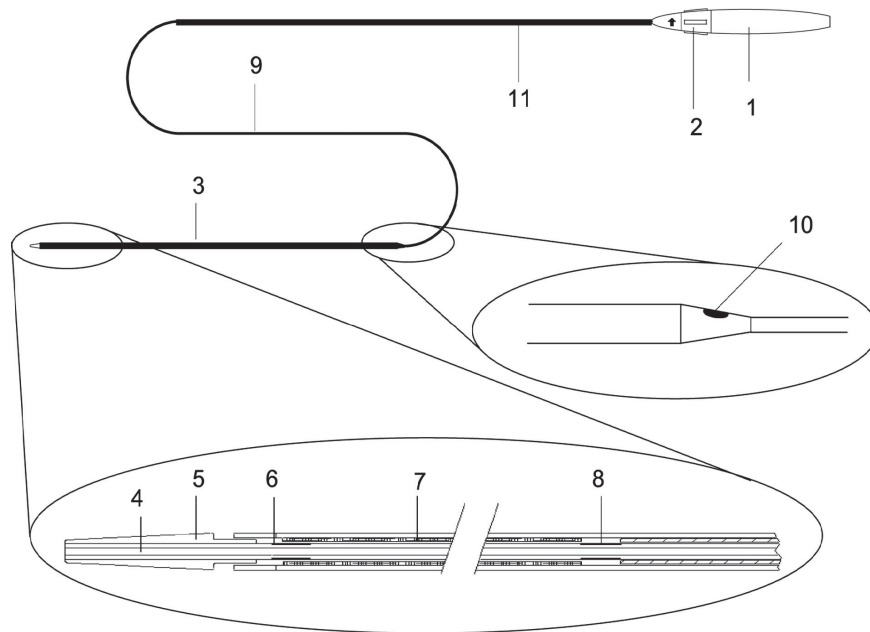

**Figure 1: XACT RX Carotid Stent System**

### Delivery System

- |                        |                               |
|------------------------|-------------------------------|
| 1. Handle              | 6. Radiopaque Distal Marker   |
| 2. Deployment Actuator | 7. XACT Stent                 |
| 3. Distal Outer Sheath | 8. Radiopaque Proximal Marker |
| 4. Guide wire Lumen    | 9. Catheter Shaft             |
| 5. Tip                 | 10. Guide Wire Exit Port      |
|                        | 11. Stabilizer                |

The delivery system has an outer diameter (OD) of 5.7 Fr. It is compatible with an 8 Fr guiding catheter or a 6 Fr sheath - with a 0.088" inner diameter or greater. The delivery system has a working length of 136 cm. See **Figure 1** for a graphical depiction of the XACT Stent System. The delivery system is comprised of a tip (5), distal outer sheath (3), catheter shaft (9), and stabilizer (11). The distal outer sheath houses the crimped XACT stent (7). At the proximal end of the distal outer sheath is the guide wire exit port (10). The proximal portion of the shaft and stabilizer connects the delivery system to the handle (1). The stabilizer (11) works with the hemostatic valve on the guiding catheter / sheath to help improve stent placement accuracy during deployment.

The inner system assembly consists of a tip (5) installed over a 0.014" (0.36 mm) guide wire compatible guide wire lumen (4). The guide wire lumen (4) is flushed via the tip (5) using the flushing tip. For more detailed instructions on device flushing, see the section entitled Delivery System Preparation in this document. The crimped XACT stent is constrained between the guide wire lumen (4) and the distal outer sheath (3). Radiopaque marker bands on the delivery system are located at the proximal (8) and distal (6) ends of the stent. Prior to deployment, these radiopaque markers are used as guides to position the stent.

Deployment of the XACT stent is achieved by grasping the handle (1) and rotating the deployment actuator (2) in a clockwise direction. See **Section 8.7 Stent Deployment**, for detailed instructions on deploying the stent.

### Tapered Stent

This stent is designed to fit tapered carotid anatomy, especially lesions involving the carotid bifurcation (**Figure 2**).

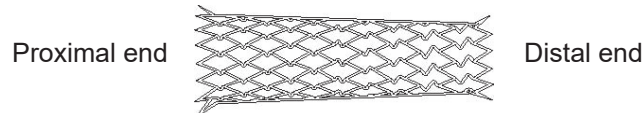

**Figure 2: Tapered Stent**

### Straight Stent

This stent is designed to be used within non-tapered carotid anatomy and lesions not involving the bifurcation (**Figure 3**).

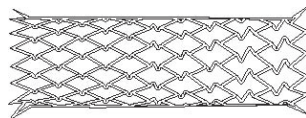

**Figure 3: Straight Stent**

**Table 1: Device Range**

Catalogue No.	Stent Length	Configuration	Unconstrained Stent Diameter
82095-01	20 mm	Straight	7 mm
82093-01	20 mm	Straight	8 mm
82089-01	20 mm	Straight	9 mm
82099-01	20 mm	Straight	10 mm
82094-01	30 mm	Straight	7 mm
82092-01	30 mm	Straight	8 mm
82088-01	30 mm	Straight	9 mm
82098-01	30 mm	Straight	10 mm
82091-01	30 mm	Tapered	8 – 6 mm
82087-01	30 mm	Tapered	9 – 7 mm
82097-01	30 mm	Tapered	10 – 8 mm
82090-01	40 mm	Tapered	8 – 6 mm
82086-01	40 mm	Tapered	9 – 7 mm
82096-01	40 mm	Tapered	10 – 8 mm

## 2.0 INDICATIONS

The XACT™ Carotid Stent System (XACT), used in conjunction with compatible Embolic Protection Systems and via appropriate access approach, such as transfemoral and transcarotid approach, is indicated for the improvement of the lumen diameter of carotid arteries in patients considered at high risk for adverse events from carotid endarterectomy who require percutaneous carotid angioplasty and stenting for occlusive artery disease and meet the criteria outlined below:

- Patients with carotid artery stenosis ( $\geq 50\%$  for symptomatic patients by ultrasound or angiography or  $\geq 80\%$  for asymptomatic patients by ultrasound or angiography) located between the origin of the common carotid artery and the intracranial segment of the internal carotid artery AND
- Patients must have a reference vessel diameter ranging between 4.8 mm and 9.1 mm at the target lesion.

## 3.0 CONTRAINDICATIONS

Contraindications associated with angioplasty must be considered when using the XACT™ Carotid Stent System. These include, but are not limited to:

- Patients in whom anticoagulant and / or antiplatelet therapy is contraindicated.
- Patients with a known allergy or hypersensitivity to stent materials (nickel-titanium alloy) or contrast medium, who cannot be adequately premedicated.
- Patients with uncorrected bleeding disorders.

- Patients in whom carotid bifurcation is less than 5 cm above the clavicle (ENROUTE Transcarotid NPS only)

#### 4.0 WARNINGS

**Use of the device should be restricted to physicians or allied healthcare professionals under the direction of such physicians trained to the specifics of the device and to the Instructions for Use. Users must be knowledgeable of the current medical literature and appropriately trained on the principles, clinical applications, complications, side effects, and hazards commonly associated with carotid interventional procedures.**

This device is designed and intended for single use only. Do not reuse, reprocess or resterilize. Reuse, reprocessing or resterilization may compromise the structural integrity of the device and / or delivery system and / or lead to device failure, which may result in patient injury, illness or death. Reuse, reprocessing or resterilization may also create a risk of contamination of the device and / or cause patient infection or cross-infection, including, but not limited to, the transmission of infectious diseases(s) from one patient to another. Contamination of the device and / or delivery system may lead to injury, illness or death of the patient.

DO NOT USE if the sterile pouch is damaged.

Carefully inspect device components prior to use to verify that they have not been damaged and that the size, shape, and condition are suitable for the procedure for which they are to be used. A device or access device which is kinked or damaged in any way should not be used.

Do not use the product after the "Use by" Date specified on the label.

Refer to instructions supplied with all interventional devices to be used with the XACT™ Carotid Stent System for their intended uses, contraindications, and potential complications.

The safety and efficacy of the XACT Carotid Stent System has not been demonstrated with embolic protection systems other than Abbott Medical's Emboshield™ Family of Embolic Protection Systems and ENROUTE<sup>±</sup> Transcarotid Neuroprotection System. Refer to the Instructions for Use document for the embolic protection system that will be used for specific device instructions.

As with any vascular implant, infection secondary to contamination of the stent may lead to thrombosis, pseudoaneurysm, or rupture.

Stenting across a major bifurcation may hinder or prevent future diagnostic or therapeutic procedures.

In patients requiring antacids and / or H2-antagonists before or immediately after stent placement, oral absorption of antiplatelet agents (e.g., aspirin) may be adversely affected.



The appropriate antiplatelet and anticoagulation therapy should be administered pre- and post-procedure as suggested in these instructions. Special consideration should be given to those patients with recently active gastritis or peptic ulcer disease.

When multiple stents are required, stent materials should be of similar composition.

The safety and effectiveness of the XACT Carotid Stent System has NOT yet been established in patients with the characteristics noted below:

- Low to moderate risk for adverse events from carotid endarterectomy.
- Previously placed stent in target artery.
- Total occlusion of the target lesion.
- Angiographically visible thrombus.
- Carotid string sign (a tiny, long segment of contrast in the true lumen of the artery).
- Vessel anatomy precluding the use of the stent system or appropriate positioning of the embolic protection systems.
- Presence of carotid artery dissection prior to initiation of the procedure.
- Evidence of a stroke within the previous 30 days.
- History of ipsilateral stroke with fluctuating neurologic symptoms within 1 year.
- History of intracranial hemorrhage within the past 3 months.
- Any condition that precluded proper angiographic assessment or made percutaneous arterial access unsafe (e.g., morbid obesity, sustained systolic blood pressure > 180 mmHg).
- History or current indication of bleeding diathesis or coagulopathy, including thrombocytopenia or an inability to receive heparin in amounts sufficient to maintain an activated clot time at > 250 seconds.
- Hemoglobin (Hgb) < 8 gm/dl (unless on dialysis), platelet count < 50,000, INR > 1.5 (irreversible), or heparin-associated thrombocytopenia.
- Known cardiac sources of emboli.
- Atherosclerotic disease involving adjoining vessels (i.e., the aortic arch or ostial common carotid artery) precluding safe placement of the guiding catheter or sheath.
- Other abnormal angiographic findings that indicate the patient is at risk of a stroke due to a problem other than that of the target lesion, such as: ipsilateral arterial stenosis greater in severity than the target lesion, cerebral aneurysm, or arteriovenous malformation of the cerebral vasculature.
- Severe dementia.
- Pregnant patients or patients under the age of 18.
- Patients in whom femoral access or transcarotid access is not possible.
- Patients with aneurysmal dilation immediately proximal or distal to the lesion.

The safety and effectiveness of concurrent treatment of lesions in patients with bilateral carotid artery disease have not been established.

Keep dry. Keep away from sunlight. Do not expose to organic solvents or ionizing radiation.

Overstretching of the artery may result in rupture and life-threatening bleeding.

Appropriate anti-platelet, anticoagulant, and, if necessary, vasodilator therapy must be used during the procedure. Anticoagulant therapy sufficient to maintain an Activated Clotting Time of at least 250 seconds for the duration of the procedure is recommended.

Maintain a snug seal between the device and the hemostatic valve during insertion. Failure to observe this may result in air being drawn into the access device through the hemostatic valve. Device insertion should be performed slowly to minimize the risk of air entrainment.

During the insertion of Rapid Exchange catheters through guide catheters or sheaths, careful handling is required to ensure that air is not drawn into the hemostatic valve. Therefore, flushing of contrast media (or other fluids) is recommended before or after insertion of the catheter, but not while the catheter is within the hemostatic valve.

Do not advance any component of the XACT Stent Delivery System against significant resistance. The cause of any resistance should be determined via fluoroscopy, and remedial action should be taken.

Maintain continuous flush while removing and reinserting devices on the guide wire. Perform all exchanges slowly to prevent air embolism or trauma to the artery.

Implanting a stent may lead to dissection of the vessel distal and / or proximal to the stent. It may cause acute vessel closure requiring additional intervention (carotid endarterectomy, further dilatation, or placement of additional stents).

The stent may cause thrombus, distal embolization, or may migrate from the site of the implant down the arterial lumen. Appropriate sizing of the stent to the vessel is required to reduce the possibility of stent migration. In the event of thrombosis of the expanded stent, thrombolysis and percutaneous transluminal angioplasty (PTA) should be attempted. (Refer to **Table 26** and **Table 27** for stent sizing.)

In the event of complications such as infection, pseudoaneurysm, or fistulization, surgical removal of the stent may be required.

If Emboshield NAV<sup>6</sup>™ Embolic Protection System is used, allow for and maintain adequate distance between the XACT Carotid Stent System and the embolic protection system (EPS) to avoid potential filter engagement with the XACT Carotid Stent System tip and / or filter entanglement with the deployed stent. If filter engagement and / or entanglement or filter detachment occurs, surgical conversion or additional catheter-based intervention may be required.

During stent placement, 1.5 cm of the vessel should be left between the distal margin of the stent and the Emboshield NAV<sup>6</sup> Filtration Element. The stent delivery system should not contact the Emboshield NAV<sup>6</sup> Filtration Element.

**If ENROUTE<sup>±</sup> Transcarotid Neuroprotection System is used, do not grip the catheter shaft section (Figure 1, No. 9) during deployment which may affect the stent deployment accuracy.**

Ensure optimal positioning of the stent prior to deployment. Once deployment is initiated, the stent cannot be repositioned or recaptured. Stent retrieval methods (use of additional wire, snares, and / or forceps) may result in additional trauma to the carotid vasculature and or the vascular access site. Complications may include death, stroke, bleeding, hematoma, or pseudoaneurysm.

Caution should be used if pre-dilating the lesion without embolic protection as this may increase the risk of an adverse outcome.

To reduce the potential of emboli during lesion crossing, the device should be carefully manipulated and not advanced against resistance.

Confirm the compatibility of the XACT Stent Delivery System with the other interventional devices intended for use in the procedure. (Refer to Section 8.1)

Do not attempt to reposition the delivery system once the stent has made contact with the vessel wall.

Do not torque the XACT Carotid Stent System.

If resistance is met during delivery system introduction, the system should be withdrawn and another system used.

Should unusual resistance be felt at any time during removal of Delivery System post-stent implantation, the entire system should be removed together with the introducer sheath or guiding catheter as a single unit.

Persons with known history of allergies to any of the components of the XACT Carotid Stent System listed below may suffer an allergic reaction to this device. Prior to use on the patient, the patient should be counselled on the materials contained in the device, and a thorough history of allergies must be discussed. The delivery system contains stainless steel, polyether block amide, polytetrafluoroethylene, polyamide, silicone, polyethylene, polyetheretherketone, polyimide, tungsten, barium sulphate, and platinum-iridium alloy.

## **5.0 PRECAUTIONS**

Precautions to prevent or reduce clotting should be taken when any interventional device is used. Flush or rinse all devices entering the vascular system with sterile isotonic heparinized saline prior to use.

Do not remove the stent from its delivery system, as removal may damage the stent. The stent and delivery system are intended to be used in tandem. If removed, the stent cannot be put back on the delivery system.

The delivery system should not be used in conjunction with other stents.

Femoral venous access should be available during carotid stenting to manage potential hemodynamic instability (i.e., bradycardia and / or hypotension) by either pharmaceutical intervention or placement of a temporary pacemaker if needed.

The device must only be flushed using the 3 ml syringe and flushing tip provided.

The outside diameter of the Outer Sheath is 5.7 Fr. An appropriately sized sheath / guiding catheter should be selected based on this diameter.

Do not use if the stent is partially deployed within the stent delivery system.

If, after preparation, a gap between the catheter tip and the outer sheath exists, rotate the Deployment Actuator in an counter-clockwise direction until the gap is closed.

Advancement and deployment of the XACT™ Carotid Stent System should only be performed under fluoroscopic observation.

If more than one stent is required to cover the lesion, or if there are multiple lesions, the most distal lesion should be stented first, followed by the stenting of the proximal lesion. Stenting in this order obviates the need to cross the proximal stent for placement of the distal stent and reduces the chance of dislodging stents that have already been placed.

If an overlap of sequential stents is necessary, the amount of overlap should be kept to a minimum. In no instance, should more than 2 stents ever overlap.

Do not attempt to pull a partially expanded stent back through the guiding catheter or sheath; dislodgment of the stent from the delivery system may occur.

For use via the femoral approach, the XACT Carotid Stent System must be used with a guiding catheter or introducer sheath to maintain adequate support of the 0.014" (0.36 mm) guide wire throughout the procedure.

For use via the transcarotid artery revascularization (TCAR) approach, the XACT Carotid Stent System must be used with a guiding catheter or transcarotid arterial sheath to maintain adequate support of the 0.014" (0.36 mm) guide wire throughout the procedure.

Do not expose the delivery system to organic solvents (e.g., alcohol) as the device's structural integrity and / or function may be impaired.

Care must be exercised when crossing a newly deployed stent with other interventional devices to avoid disrupting the stent geometry and placement of the stent.

The deployment actuator should not be rotated before the undeployed stent within the RX delivery system has been positioned at its intended deployment location.

## 5.1 MRI Information

 MR Conditional	
MRI Safety Information	
<p>Nonclinical testing has demonstrated that the XACT Carotid Stent is MR Conditional for single and overlapping lengths up to 75 mm in length. A person with the XACT Carotid Stent may be safely scanned under the following conditions. Failure to follow these conditions may result in injury.</p>	
<b>Device Name</b>	<b>XACT Carotid Stent</b>
Static Magnetic Field Strength (B0)	1.5 or 3 Tesla
Maximum Spatial Field Gradient	3000 gauss/cm (30 T/m)
Maximum Gradient Slew Rate	200 T/m/s per axis
RF Excitation	Circularly Polarized (CP)
RF Transmit Coil Type	There are no Transmit Coil restrictions
Operating Mode	Normal Operating Mode
Maximum MR System reported whole-body-averaged specific absorption rate (SAR)	2.0 W/kg (normal operating mode)
Scan Duration	60 minutes of continuous RF scanning with 2 W/kg whole-body average SAR
MR Image Artifact	The presence of this implant may produce an image artifact.

The XACT Carotid Stent should not migrate in this MRI environment. Nonclinical testing at field strengths greater than 3 Tesla has not been performed to evaluate stent migration or heating. MRI at 1.5 or 3 Tesla may be performed immediately following the implantation of the XACT Carotid Stent.

## 6.0 ADVERSE EVENTS

### 6.1 Observed Adverse Events

The SECuRITY Registry Study was a prospective, multicenter, non-randomized study performed to demonstrate the safety and effectiveness of the Emboshield NAV<sup>6</sup>™ Embolic Protection System and XACT™ Carotid Stent System in treating carotid stenosis in patients at high risk ( $\geq 50\%$  for symptomatic patients by ultrasound or angiography or  $\geq 80\%$  for asymptomatic patients by ultrasound or angiography) for carotid endarterectomy. High-risk patients were defined as having an anatomical risk factor(s) and / or a co-morbidity risk factor(s). A total of three hundred and five (305) patients were enrolled at 30 sites in the United States and Australia.

Non-stroke neurological includes events such as visual / speech disturbances, confusion, seizure, weakness, and TIA.

TLR is defined as any repeat invasive procedure, including angioplasty, stenting endarterectomy, or thrombolysis, performed to open or increase the luminal diameter inside or within 10 mm of the previously treated lesion. To be considered clinically indicated, the patient must be symptomatic with  $> 50\%$  stenosis or asymptomatic with  $> 80\%$  stenosis.

Adverse events are categorized by body system and are defined as follows:

- Access site complications include events such as bruising, hematoma, and bleeding.
- Vascular includes events such as peripheral vascular disease and deep vein thrombosis.
- Hemodynamic includes events such as hypo- and hypertension, syncope, and dizziness.
- Bleeding includes events such as non-access site bleeding, anemia up to 30 days, and Gastrointestinal (GI) bleeds up to 30 days.
- Blood dyscrasia includes events such as anemia later than 30 days, and thrombocytopenia.
- Respiratory includes events such as pneumonia, embolism, chronic obstructive pulmonary disease (COPD), and respiratory arrest.
- GI includes events such as nausea, ulcers and GI bleeds later than 30 days.
- Genitourinary includes events such as urinary tract infection, and prostatic hyperplasia.
- Infection includes events such as abscess, sepsis, and groin infection.
- Metabolic includes events such as electrolyte imbalance, diabetes Mellitus, and renal failure.
- Musculoskeletal includes events such as pain, fractures, and joint replacements.

The numbers and types of adverse events observed were anticipated given the high co-morbid state of these patients.

**Table 2** presents the adverse events that were reported within the first 30 days following the procedure for registry patients enrolled in the SECuRITY Registry Trial. **Table 3** presents the adverse events that were reported within the first year following the procedure for registry patients enrolled in the SECuRITY Registry Trial. **Table 4** presents the cause of any patient deaths throughout the study.

**Table 2: Serious Adverse Events Summary, Up to 30 Days**

Event	≤ 30 days SECURITY (N = 305)	
	n	%
Death	3	0.98%
Stroke-Related (neurological)	3	0.98%
Not Stroke-Related	0	0%
All Strokes	21	6.89%
Major	8	2.62%
Ipsilateral Stroke	7	2.30%
Non-ipsilateral Stroke	1 <sup>1</sup>	0.33%
Minor	13	4.26%
Ipsilateral Stroke	12	3.93%
Non-ipsilateral Stroke	1 <sup>2</sup>	0.33%
Non-Stroke Neurological	25	8.20%
Restenosis (≥ 50% stenosis as measured by ultrasound)	7	2.29%
Target Lesion Revascularization (TLR), Clinically Indicated	0	0%
Cardiac	15	4.92%
MI	2	0.66%
Arrhythmia	4	1.31%
Angina	4	1.31%
Congestive Heart Failure (CHF)	3	0.98%
Coronary Artery Disease (CAD)	2	0.66%
Procedural Complication	109	35.74%
Hypotension	86	28.20%
Arrhythmia	7	2.30%
Vasospasm	3	0.98%
Dissection	10	3.28%
In-stent Thrombosis	1	0.33%
Emergent CEA	1	0.33%
Emergent Intervention -other	1	0.33%
Access Site Complication		
Requiring Repair / Transfusion	8	2.62%
Vascular	3	0.98%
Hemodynamic	11 <sup>3</sup>	3.61%
Bleeding	6	1.97%
Requiring transfusion	1	0.33%
GI Bleeding	5	1.64%
Blood Dyscrasia	2	0.66%
Respiratory	5	1.64%
Gastrointestinal	18	5.90%
Genitourinary	3	0.98%
Infection	2	0.66%
Metabolic	11	3.61%
Musculoskeletal	32	10.49%
Miscellaneous <sup>4</sup>	1	0.33%

<sup>1</sup>Stroke adjudicated as contralateral

<sup>2</sup>Stroke adjudicated as bilateral

<sup>3</sup>Includes hypotension and hypertension not associated with the procedure.

<sup>4</sup>Aortic Aneurysm Repair

**Table 3: Serious Adverse Events Summary, Up to 365 Days**

Event	31 – 365 days SECURITY (N = 302)		0 – 365 days SECURITY (N = 305)	
	n	%	n	%
Death	26	8.6	29	9.5
Stroke-Related (neurological)	3	1.0	6	2.0
Not Stroke-Related	23	7.6	23	7.5
Unknown	0	0.0	0	0
Ipsilateral Stroke	5	1.7	24	7.9
Major	4	1.3	11	3.6
Minor	1	0.3	13	4.3
Non-ipsilateral Stroke	1	0.3	2	0.7
Non-Stroke Neurological	18	6.0	43	14.1
Restenosis (≥ 50% stenosis as measured by ultrasound)	14	4.6	20	6.6
Target Lesion Revascularization (TLR), Clinically Indicated	2	0.7	2	0.7
Cardiac	57	18.9	74	24.3
MI	5	1.7	7	2.3
Arrhythmia	6	2.0	10	3.3
Angina	6	2.0	10	3.3
Congestive Heart Failure (CHF)	10	3.3	15	4.9
Coronary Artery Disease (CAD)	30	9.9	32	10.5
Procedural Complication	0	0.0	109	35.74
Hypotension	0	0.0	86	28.20
Arrhythmia	0	0.0	7	2.30
Vasospasm	0	0.0	3	0.98
Dissection	0	0.0	10	3.28
In-stent Thrombosis	0	0.0	1	0.33
Emergent CEA	0	0.0	1	0.33
Emergent Intervention -other	0	0.0	1	0.33
Access Site Complication Requiring Repair / Transfusion	0	0	8	2.62
Vascular	42	13.9	45	14.7
Hemodynamic	25	8.3	36	11.8
Bleeding	4	1.3	10	3.3
Requiring transfusion	1	0.3	2	0.7
GI Bleeding	3	1.0	8	2.6
Blood Dyscrasia	9	3.0	11	3.6
Respiratory	15	5.0	20	6.6
Gastrointestinal	8	2.6	26	8.5
Genitourinary	8	2.6	11	3.6
Infection	6	2.0	8	2.6
Metabolic	14	4.6	25	8.2
Musculoskeletal	19	6.3	51	16.7
Miscellaneous <sup>1</sup>	4	1.3	5	1.6

<sup>1</sup>Adenocarcinoma, aortic aneurysm repair, aortic valve replacement and malignant hepatic neoplasm



**Table 4: Cause of Death (< 30 days, 31 – 365 days)**

Cause of Death	0 – 30 days		31 – 365 days	
	n	%	n	%
Stroke (neurological)	3	0.98	3	0.99
Cardiac	0	0.00	10	3.31
Cancer	0	0.00	4	1.32
Renal Failure	0	0.00	3	0.99
Respiratory	0	0.00	1	0.33
Diabetes	0	0.00	1	0.33
Device related deaths	0	0.00	0	0.00
Accidental	0	0.00	1	0.33

## 6.2 Potential Adverse Effects

As reported in the literature, the following adverse events are potentially associated with carotid stents and embolic protection systems:

- Allergic reaction or hypersensitivity to latex, contrast agent, anesthesia, stent materials (nitinol, nickel, titanium), and drug reactions to anticoagulation, or antiplatelet drugs
- Vascular access complications which may require transfusion or vessel repair, including:
  - Catheter site reactions
  - Bleeding (ecchymosis, oozing, hematoma, hemorrhage, retroperitoneal hemorrhage)
  - Arteriovenous fistula, pseudoaneurysm, aneurysm, dissection, perforation / rupture, and laceration
  - Embolism (air, tissue, plaque, thrombotic material or device)
  - Thrombophlebitis
- Target artery complications which may require additional intervention, including:
  - Total occlusion or abrupt closure
  - Arteriovenous fistula, pseudoaneurysm, aneurysm, dissection, perforation / rupture
  - Embolism (air, tissue, plaque, thrombotic material or device)
  - Artery, stent, or filter thrombosis / occlusion thrombosis
  - Stenosis or restenosis
  - Vessel spasm or recoil
- Cardiac arrhythmias (including conduction disorders, atrial and ventricular arrhythmias)
- Cardiac ischemic conditions (including myocardial ischemia, myocardial infarction, and unstable or stable angina pectoris)
- Stroke / Cerebrovascular accident (CVA) and Transient Ischemic Attack (TIA)
- System organ failure:
  - Cardio-respiratory arrest
  - Cardiac failure
  - Cardiopulmonary failure (including pulmonary edema)
  - Renal failure / insufficiency
  - Shock
- Bleeding
- Blood cell disorders, including Heparin-induced thrombocytopenia (HIT) and other coagulopathy

- Hypotension / hypertension
- Peripheral nerve injury
- Other ischemic conditions / infarct
- Infection – local and systemic (including post-procedural)
- Nausea and vomiting
- Chest pain
- Dyspnea
- Edema / cerebral edema and fluid overload
- Fever
- Pain, including headache
- Hyperperfusion syndrome
- Other neurologic and systemic complications
  - Seizure
- Cerebral hemorrhage
- Death
- Device-related complications which may require additional intervention, including:
  - Detachment and / or implantation of a component of the system
  - Stent / filter entanglement / damage
  - Stent malposition
  - Stent migration / embolization
- Emergent or urgent endarterectomy surgery (CEA)

Any adverse event occurring involving this device should be reported immediately to Abbott Vascular, Customer Service: 1 (800) 227-9902.

## **7.0 SYNOPSIS OF CLINICAL STUDY**

### **7.1 SECuRITY Registry Trial**

The SECuRITY Registry Trial was a prospective, multicenter, non-randomized safety and efficacy study of an embolic protection device and a carotid artery stent in 305 pivotal patients and 93 lead-in patients with carotid artery disease conducted at 30 sites.

The primary endpoint was the incidence of Major Adverse Events (MAEs), defined as death, stroke or myocardial infarction (Q-wave and non Q-wave) at 30-days post-procedure for the Emboshield Embolic Protection System and MAE (death, stroke or MI) at 30 days post-procedure and the incidence of ipsilateral stroke at one year for the XACT Stent. Secondary endpoints were the incidence of vascular complications other than MAEs at 30 days, and restenosis and / or target lesion revascularization (TLR) at 6 months and one year post-procedure.

#### **Study Objective**

The primary objective of the study was to evaluate the safety and efficacy of the XACT™ Carotid Stent System and the Emboshield Embolic Protection System in treating carotid stenosis in patients at high risk for carotid endarterectomy ( $\geq 50\%$  stenosis for symptomatic patients by ultrasound or angiography or  $\geq 80\%$  for asymptomatic patients by ultrasound or angiography).

## Investigational Devices

The investigational devices used over the duration of the SECuRITY Registry Trial consisted of the Rapid Exchange (RX) and Over the Wire (OTW) versions of the XACT Carotid Stent System and the RX and OTW Emboshield Embolic Protection System.

The XACT Carotid Stent System is comprised of a self expanding, nitinol stent that is specifically designed for use in carotid interventional procedures and a delivery system.

**Table 5** below provides an outline of the SECuRITY Registry endpoints.

The Emboshield system is comprised of a Filtration Element, a BareWire (guide wire), a Delivery Catheter and a Retrieval Catheter. The Emboshield system is a temporary percutaneous, transluminal intra-arterial filtration system, which is placed distal to the target lesion. The Filtration Element is designed to appose the vessel wall distal to the target lesion in order to capture potential emboli thereby reducing the chance of distal embolization while maintaining blood flow during carotid angioplasty and stent procedures. The filtration element and retrieval catheter are removed from the patient upon completion of the procedure.

**Table 5: Study Endpoints**

Endpoint	Definition
Primary Endpoint	Incidence of Major Adverse Events (MAEs), defined as death, stroke or myocardial infarction (Q-wave and non Q-wave) at 30-days post-procedure for the Emboshield Embolic Protection System and MAE (death, stroke or MI) at 30 days post-procedure and the incidence of ipsilateral stroke at one year for the XACT Stent.
<b>Secondary Endpoints</b>	<b>Definition</b>
Safety	Incidence of vascular complications other than MAE at one month.
Acute Success	<b>Lesion success:</b> defined as < 50% residual stenosis of the target lesion using the XACT stent and Emboshield filter. <b>Device success:</b> XACT Stent: < 50% residual stenosis in the target lesion. Emboshield Filter: Deployment and retrieval of the device during the procedure, in the absence of angiographic distal embolization.
Procedure success	Defined as < 50% residual stenosis of the target lesion using any method, and the absence of major adverse events at 30 days.
Long Term Success	<b>Restenosis:</b> defined as a narrowing > 50% at 6 and 12 months post-procedure, as determined by ultrasound. <b>Revascularization:</b> target lesion revascularization associated with a narrowing of > 80% within 12 months post procedure.

## Statistical Methods

The proportion of patients experiencing a primary endpoint adverse event in the SECuRITY Registry was compared to a weighted historical control (WHC) rate based on a review of outcome assessments for endarterectomy published in peer reviewed literature. It was established that the one-year control rate for patients having high-risk co-morbidities was 14% and the one-year control rate for patient with anatomic risk factors was 11%. The WHC rate for this trial was then computed by weighting these rates by the actual proportion of patients in the study with co-morbidities versus anatomic risk factors.

Patients with at least one high-risk co-morbidity:  $266/303 = 87.8\%$

Patients with anatomic risk factors only:  $37/303 = 12.2\%$

WHC =  $(87.8\% \times 14\%) + (12.2\% \times 11\%) = 13.6\%$

All patients who met eligibility requirements, and who were available for clinical follow-up, were included in the denominator. Two (2) patients had neither high-risk co-morbidities nor anatomic risk factors and were excluded from the calculation of the weighted historic control.

The analysis and subsequent interpretation of the results from this study are based on inferential statistics. The test statistic used for this analysis was the Clopper-Pearson method for calculating 95% binomial confidence intervals, based on the observed primary composite endpoint failure rate. If the upper bound of the 95% binomial confidence interval was found to be less than the WHC plus the margin of clinical equivalence, the null hypothesis would be rejected and non-inferiority of the XACT stent to CEA would be demonstrated.

The SECuRITY protocol required regular patient follow-up by the treating physician and follow-up neurological assessments by a neurologist. Core laboratories provided independent assessments for the angiographic, ultrasound, ECG, and pathologic evaluation of captured debris (Emboshield filter only). Medical monitors reviewed all safety data to ensure appropriate reporting of adverse events. A Clinical Adjudication Committee adjudicated suspected primary endpoint events. A Data Safety Monitoring Board monitored adverse events to ensure patient safety.

### **Eligibility Criteria Summary**

Eligible patients were male and female adults with a lesion in the internal carotid artery or internal carotid artery extending into the common carotid artery who were at high risk for CEA.

All patients had to meet the following inclusion criteria to be considered for the study:

The patient had a carotid artery stenosis ( $\geq 50\%$  for symptomatic patients or  $\geq 80\%$  for asymptomatic patients by ultrasound or angiography), located between the origin of the common carotid artery and the intra-cranial segment of the internal carotid artery.

Patient was  $\geq 18$  years of age.

Patient had a lesion located in the internal carotid artery.

Target Internal Carotid Artery (ICA) vessel diameter was visually estimated to be  $\geq 4.0$  mm and  $\leq 9.0$  mm for XACT stent treatment segment and to be  $\geq 3.5$  mm and  $\leq 6.0$  mm for the Emboshield filter.

Anticipated life expectancy of the patient was at least one year.

The patient (or their legal guardian) understood the nature of the procedure and provided written informed consent.

Patient was willing to comply with the protocol requirements and to return to the treatment center for all required clinical evaluations.

Patient had no childbearing potential or a negative pregnancy test within 5 days of the study procedure.

Each patient had to fulfill at least one (1) of the anatomical risk factors or co-morbid risk factors listed below to be inclusion in the study:

### **Anatomic Risk Factors**

Previous radiation treatment to the neck or radical neck dissection

Target lesion was at or above the second vertebral body C2 (level of jaw)

Inability to extend the head due to cervical arthritis or other cervical disorders

Tracheostomy or tracheal stoma

Laryngectomy

Contralateral laryngeal nerve palsy

Severe tandem lesions

### **Co-morbid Risk Factors**

Previous carotid endarterectomy with significant restenosis (as defined above for symptomatic or asymptomatic patients)

Total occlusion of the contralateral carotid artery

Left ventricular ejection fraction < 35%

Congestive Heart Failure New York Heart Association (NYHA) Functional Class III or higher

Dialysis dependent renal failure

Canadian Cardiovascular Society Angina Classification III or higher or unstable angina

Requires simultaneous or staged coronary artery bypass surgery, cardiac valve surgery, peripheral vascular surgery, or abdominal aortic aneurysm repair within 60 days

> 80 years of age

Myocardial infarction within previous 6 weeks

Abnormal stress test. Treadmill, thallium or dobutamine echo were acceptable. The stress tests had to be sufficiently abnormal to place the patient at an increased risk for CEA

Severe pulmonary disease, including at least one of the following: requirement chronic O2 therapy, resting PO2 ≤ 60 mm Hg, Hematocrit ≥ 50%, FEV1 or DLCO ≤ 50% of normal

## Description of Patients Evaluated

**Table 6** summarizes the patient follow-up and includes one patient that died three hundred seventy four (374) days post index procedure.

**Table 6: SECURITY Patient Follow-up**

	30-days	6-months	12-months
Patients Enrolled	305		
Cumulative Death	3	13	26
Cumulative Withdrawal or Loss-to-Follow-up	10	26	36
Patients Evaluable	302	292	279
Patients Evaluated	292	266	243
Follow-up Rate (%)	96.7	91.1	87.1

Baseline demographics and lesion characteristics for the SECURITY Registry Trial are presented in **Table 7**.

**Table 7: Baseline Demographics**

Demographic	SECURITY Trial
<b>Age</b>	
Mean ± SD	74.5 ± 9.1
Range (min, max)	48.0, 92.2
Age > 80 years	33.8% (103/305)
<b>Gender</b>	
Male	63.6% (194/305)
Females	36.4% (111/305)
<b>Medical History</b>	
Diabetes	30.8% (94/305)
Hypertension requiring treatment	86.6% (264/305)
Hyperlipidemia	73.8% (225/305)
Current Smoker	72.5% (221/305)
<b>Number of Symptomatic Patients</b> (TIA, / stroke within 180 days)	21% (64/305)
<b>Baseline Lesion &amp; Vessel Characteristics</b>	
Eccentric	29.0% (87/300)
Concentric	71.0% (213/300)
Calcified	21.0% (63/300)
Ulcerated	23.0% (69/300)
<b>Lesion Length</b>	
Mean ± SD	15.0 ± 6.5
Range (min, max)	2.0, 46.8

<b>Demographic</b>	<b>SECURITY Trial</b>
<b>Minimum Lumen Diameter (MLD, mm)</b>	
Mean ± SD	4.8 ± 0.9 (n = 299)
Range (min, max)	0.8, 9.5
<b>Percent Diameter Stenosis (%DS)</b>	
Mean ± SD	73.2 ± 17.3 (n = 299)
Range (min, max)	-160, 93.2
<b>High-Risk Inclusion Criteria</b>	
<b>Anatomic Risk Factors</b>	
Previous Radiation Treatment to Neck or Radical Neck Dissection	5.9% (18/305)
Target Lesion At or Above Second Vertebral Body C2	9.2% (28/305)
Inability to Extend the Head Due to Cervical Arthritis or Other Cervical Disorders	3.0% (9/305)
Tracheostomy or Tracheal Stoma	0.0% (0/305)
Laryngectomy	0.3% (1/305)
Contralateral Laryngeal Nerve Palsy	0.0% (0/305)
Severe Tandem Lesions	1.3% (4/305)
<b>Co-Morbid Risk Factors</b>	
Previous Carotid Endarterectomy with Significant Restenosis	21.0% (64/305)
Total occlusion of the Contralateral Carotid Artery	8.9% (27/305)
Left Ventricular Ejection Fraction < 35%	79.9% (24/305)
Congestive Heart Failure NYHA III or Higher	6.2% (19/305)
Dialysis Dependent Renal Failure	1.6% (5/305)
CCSAC III or Higher or Unstable Angina	7.5% (23/305)
Requires Simultaneous or Staged CABG, Cardiac Valve Surgery, Peripheral Vascular Surgery, or Abdominal Aortic Aneurysm Repair Within 60 Days	7.2% (22/305)
> 80 Years of Age	33.8% (103/305)
MI Within Previous 6 Weeks	0.7% (2/305)
Abnormal Stress Test	12.1% (37/305)
Severe Pulmonary Disease	2.0% (6/305)

## Results

At 30 days following the study procedure, 92.5% of the treated patients were free of major adverse events (MAEs), defined as death, stroke or myocardial infarction. The primary endpoint of the study was a composite rate of the 30-day MAEs and ipsilateral strokes at one year. The composite rate of occurrence for the primary endpoint measure at 12 months was 8.5%.

Acute success in effectively treating the target lesion was demonstrated in 96.7% (295/305) of the patients undergoing the study procedure. Device success was also achieved in a majority of the study procedures for both study devices: 94.1% (287/305) for the XACT stent and 96.7% (295/305) for the Emboshield Embolic Protection System.

Overall procedural success was demonstrated in 269 patients (88.2%), as measured by a residual stenosis of < 50% at the completion of the procedure and the absence of major adverse events (MAE; Stroke, Death, or MI) at 30 days. Five (5) patients (1.6%, 5/305), experienced a vascular complication that required treatment with additional therapeutic measures, including aspiration of a stagnate column of blood prior to filter retrieval, placement

of a second stent, application of a pressure dressing to the access site and surgical drainage for a groin abscess.

Change to minimum lumen diameter (MLD) was calculated for 299 patients where the MLD measured was the section (segment) of the carotid considered for stenting. The average change was 2.3 mm and the average percent change in lumen diameter was – 55.5%.

At 12 months, long-term durability of the procedure was also demonstrated by 99.3% (0.7%, 2/305) of the treated patients being free from repeat revascularization. Additionally, at 6 months and 12 months post-procedure, restenosis was demonstrated in a small percentage of the patient population, 4.9% and 4.1%, respectively.

In the SECURITY trial the median number of days-to-discharge was 1.7. The longest hospital stay post-stenting in each study was 16 days. Approximately, 70% of patients in the SECURITY Trial remained in the hospital for 1 day following the carotid stenting procedure. Additionally, 6% of patients stayed 5 or more days, generally for the treatment of a co-morbid condition.

The primary objective of the SECURITY trial was met. The upper bound of the 95% one-sided binomial confidence interval was found to be less than the WHC plus the margin of clinical equivalence, demonstrating that the carotid stenting with the XACT stent is non-inferior to carotid endarterectomy.

The clinical results of this study indicate that the XACT Carotid Stent System, when used in conjunction with the Emboshield Embolic Protection System, provides a safe, effective and durable method for the treatment of carotid stenosis in patients at high-risk for carotid endarterectomy.



**Table 8: Non-Hierarchical Summary of Safety Measures in the SECuRITY Trial**

Events	≤ 30 days SECuRITY (N = 305)	
	n	%
30-day Primary Endpoint (Death, Stroke and MI)	23	7.5%
Death	3	0.98%
Stroke-Related (neurological)	3	0.98%
Not Stroke-Related	0	0%
All Strokes	21	6.89%
Major	8	2.62%
Ipsilateral Stroke	7	2.30%
Non-ipsilateral Stroke	1 <sup>1</sup>	0.33%
Minor	13	4.26%
Ipsilateral Stroke	12	3.93%
Non-ipsilateral Stroke	1 <sup>2</sup>	0.33%
Non-Stroke Neurological	25	8.20%
Cardiac	15	4.92%
MI	2	0.66%
Arrhythmia	4	1.31%
Angina	4	1.31%
Congestive Heart Failure (CHF)	3	0.98%
Coronary Artery Disease (CAD)	2	0.66%
Procedural Complication	109	35.74%
Hypotension	86	28.20%
Arrhythmia	7	2.30%
Vasospasm	3	0.98%
Dissection	10	3.28%
In-stent Thrombosis	1	0.33%
Emergent CEA	1	0.33%
Emergent Intervention -other	1	0.33%
Access Site Complication Requiring Repair / Transfusion	8	2.62 %
Vascular	3	0.98 %
Hemodynamic	11 <sup>3</sup>	3.61%
Bleeding	6	1.97%
Requiring transfusion	1	0.33%
GI Bleeding	5	1.64%
Blood Dyscrasia	2	0.66%
Respiratory	5	1.64%
Gastrointestinal	18	5.90%
Genitourinary	3	0.98%
Infection	2	0.66%
Metabolic	11	3.61%
Musculoskeletal	32	10.49%
Miscellaneous <sup>4</sup>	1	0.33%

<sup>1</sup>Stroke adjudicated as contralateral

<sup>2</sup>Stroke adjudicated as bilateral

<sup>3</sup>Includes hypotension and hypertension not associated with the procedure

<sup>4</sup>Aortic aneurysm repair

**Table 9: Summary of Efficacy Measures in the SECURITY Trial**

<b>Efficacy Measures</b>	<b>%</b>	<b>95% CI</b>	<b>X / n</b>
<b>One Year Primary Endpoint</b> (Stroke, Death, MI within 30 days plus ipsilateral stroke 31 – 365 days)	8.5	(-, 0.116)	(26/305)
<b>Lesion Success</b> (< 50% stenosis using the XACT stent and Emboshield filter)	96.7%	(0.941, 0.984)	(295/305)
<b>Device Success – XACT Stent</b> (< 50% residual stenosis, successful delivery of the stent)	94.1%	(0.908, 0.965)	(287/305)
<b>Device Success – Embolic Protection Device</b> (Successful deployment / retrieval of the filter, absence of angiographic distal embolization)	96.7%	(0.941, 0.984)	(295/305)
<b>Procedural Success</b> (< 50% stenosis using any method and freedom from MAE at 30 days)	88.2%	(0.840, 0.916)	(269/305)
<b>Long Term Success</b> (absence of Ipsilateral stroke at 365 days post-procedure [0 – 365 days] )	92.2%	(0.889, 0.952)	(282/305)
<b>Restenosis</b> ( $\geq$ 50% stenosis as measured by ultrasound)*			
At 6 Months post-procedure	4.9%	(0.020, 0.067)	(12/246)*
At 12 Months post-procedure	4.1%	(0.014, 0.055)	(9/221)*
<b>Restenosis</b> (Cumulative)			
0 – 6 Months post-procedure	5.6%	Not Available	(17/305)
0 – 12 Months post-procedure	6.6%	Not Available	(20/305)
<b>Target Lesion Revascularization</b> (Surgical / percutaneous revascularization involving the target lesion within 365 days)	0.65%	(0.000, 0.018)	(2/305)
<b>Total Vascular Complications</b>	1.6%	(0.005, 0.038)	(5/305)

\*At the end of the one year follow-up period only two subjects had a clinically indicated need for revascularization.

**Table 10: Improvement in Target Lesion Lumen Diameter**

	<b>Pre-Procedure to Post-Procedure Change (n = 295**)</b>		
	<b>Change Mean</b>	<b>S.D.</b>	<b>95% CI</b>
In Lesion MLD* (mm)	2.3 mm	0.7 mm	(2.3, 2.4)
In Lesion Diameter Stenosis (%)	-55.5%	15.6%	(-57.3, -53.7)

\*Minimum Lumen Diameter of the section (segment) of the carotid considered for stenting.

\*\*Number of patients for which pre-and post-angiographic data was available.

**Figure 4: Freedom from Composite Endpoint of Stroke, Death and MI (0 – 365 days)**

**Kaplan–Meier Analysis of Time to Primary Endpoint**

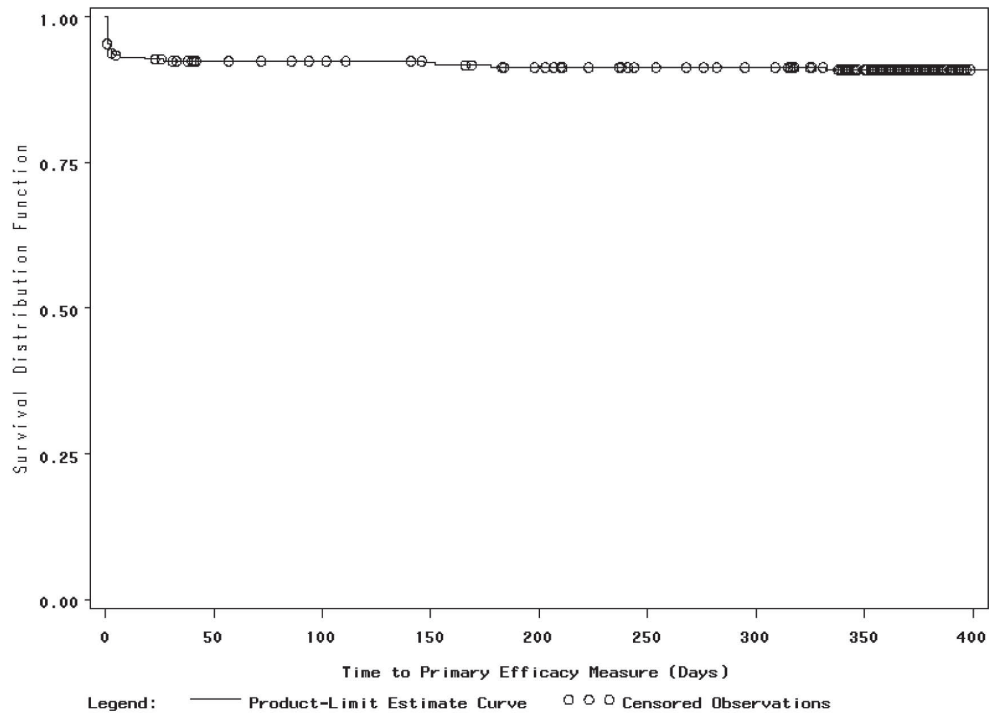

Months after Index Procedure	0	1	3	6	12
Days after Index Procedure	0	30	90	180	365
Number at Risk	305	276	264	253	157
Number Censored	0	6	18	26	121
Number of Events	0	23	23	26	27
Percent Event Free	100%	92.4%	92.4%	91.4%	91.0%
One-Sided Lower 95% CI	100%	89.9%	89.9%	88.6%	87.4%

## **7.2 EXACT Post-Approval Study**

The EXACT Post-Approval Study was a multi-center, prospective, registry study initiated after approval of the XACT Carotid Stent System. The goals of the EXACT study were:

- To collect clinical outcome and device performance data on the XACT Carotid Stent System when used in conjunction with the Emboshield BareWire Embolic Protection System, in the commercial use setting;
- To identify any rare adverse or unanticipated device related events; and
- To determine the adequacy of the Abbott Vascular training program.

A total of 2,232 patients were enrolled in the EXACT study at 128 sites by 253 participating physicians. The first EXACT patient was enrolled on November 14, 2005 and the last patient was enrolled on April 18, 2007. Of the 2,232 patients, 2,145 were evaluable, having completed their 30-day follow up visit or reached an endpoint event (death, stroke, or MI) before their follow up visit. Additionally, 658 patients completed their 1-year follow-year visit and were evaluable for an endpoint of DSMI at 30 days and an ipsilateral stroke between days 31 and 365 days.

## Baseline Patient Demographics

The baseline patient characteristics for the EXACT patients are presented in **Table 11**.

**Table 11: Patient Baseline Characteristics**

	<b>EXACT (n = 2145)</b>
Age (years)	
Mean ± (SD) <sup>1</sup>	72.88 ± 8.94
Age ≥ 80	23.8%
Gender	
Male	63.1%
<b>Medical History</b>	
Diabetes	34.6%
Hypertension	89.7%
Hypercholesterolemia	74.0%
Current Smoker	19.2%
<b>Symptomatic (stroke, TIA, amaurosis fugax ≤ 180 days)</b>	
	9.9%
<b>Cardiac Risk Factors</b>	
CHF	18.3%
MI	25.1%
Arrhythmia	19.8%
Coronary Artery Disease	70.7%
Unstable Angina	8.6%
Needs CABG within 30 Days	0.3%
<b>Non-Cardiac Risk Factors</b>	
Pulmonary	16.8%
Renal Failure	7.2%
Unfavorable Anatomic Conditions	10.8%
On a list for a Major Organ Transplant	0.9%
Contralateral Occlusion of ICA	11.2%
Peripheral Vascular Disease	44.9%
Prior CEA	2.8%
Other Risk Factor	15.9%

<sup>1</sup>By normal approximation

## Results

### 30-Day Primary Endpoint Events

**Table 12** presents the hierarchical safety event rates for the 30-day evaluable cohort. The 30-day primary composite endpoint, defined as death, stroke and MI, was 4.1%, the combined stroke and death rate was also 4.1% and the combined major stroke and death rate was 1.5%. **Table 13** presents the non-hierarchical safety events for the 30-day evaluable cohort.

**Table 12: Hierarchical Safety Events (≤ 30 days)**

	<b>EXACT (N = 2145)</b>
<b>All Death, Stroke and MI</b>	4.1%
<b>Death</b>	19
<b>All Stroke</b>	68
<b>Major Stroke</b>	14
Ipsilateral to Treated Hemisphere	12
Non-Ipsilateral to Treated Hemisphere	2
<b>Minor Stroke</b>	54
Ipsilateral to Treated Hemisphere	48
Non-Ipsilateral to Treated Hemisphere	6
<b>MI</b>	2
<b>All Death , Stroke</b>	4.1%
<b>Death, Major Stroke</b>	1.5%

Table includes only the most serious event for each subject and includes only each subject's first occurrence of each event.

**Table 13: Non-Hierarchical Safety Events (≤ 30 days)**

	<b>EXACT (N = 2145)</b>
<b>Death</b>	0.9% (19/2145)
<b>All Stroke</b>	3.6% (77/2145)
<b>Major Stroke</b>	1.1% (23/2145)
Ipsilateral to Treated Hemisphere	1.0% (21/2145)
Non-Ipsilateral to Treated Hemisphere	0.1% (2/2145)
<b>Minor Stroke</b>	2.5% (54/2145)
Ipsilateral to Treated Hemisphere	2.2% (48/2145)
Non-Ipsilateral to Treated Hemisphere	0.3% (6/2145)
<b>MI</b>	0.2% (4/2145)

Table includes only each subject's first occurrence of each event.

### **1-Year Primary Endpoint Events**

The second co-primary endpoint for the EXACT study was a composite of stroke, death, and MI at 30 days and ipsilateral stroke at 12 months (31 – 365 days). Figure 5 shows the Kaplan-Meier curve for the 1-year cohort, comprised of 658 patients. In this 1-year cohort, 4 first events of ipsilateral strokes occurred between days 31 and 365 and the composite 1-year endpoint rate was 6.1% and the 30 day DSMI rate was 5.3% based on the Kaplan-Meier analysis. The annualized ipsilateral stroke rate beyond 30 days was analyzed and a second Kaplan-Meier curve was computed beginning at day 31 (Figure 6). A total of 5 events occurred between 31 and 365 days post procedure resulting in an event free rate of 99% at 1-year. Based on this analysis, the annualized ipsilateral stroke rate between 31 and 365 days was 1%.

**Figure 5: Kaplan Meier Curve – Freedom From DSMI (to 30 Days) or Ipsilateral Stroke (to 365 Days)**

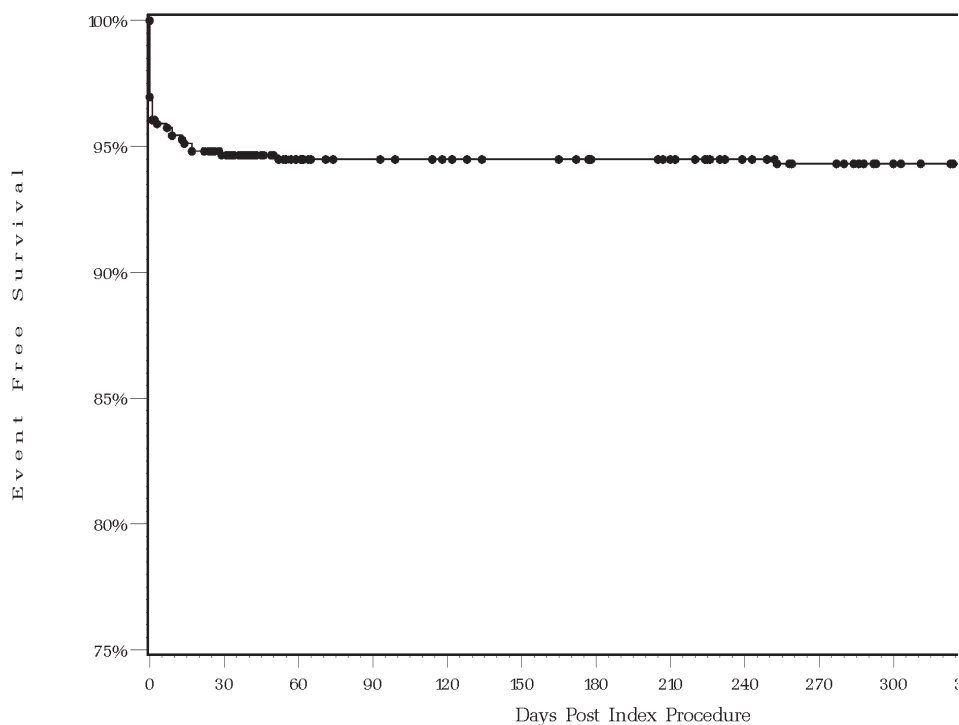

Days After Index Procedure	0	(0, 30]	(30, 180]
# At Risk	658	638	599
# Censored	0	24	50
# Events	20	15	1
% Event Free	97.0%	94.7%	94.5%
% Standard Error	0.7%	0.9%	0.9%

Source: \\ASE\Rept2008-02\rpgm\exact\_surv\_curve May 13, 2008 (15:46)

**Note:** # At Risk gives the number of patients at risk of an event at the start of the interval, while # Censored and # Events are the incremental counts of patients censored or with events during the interval. The intervals are denoted as half-open bracket expression, where the start of interval '(' is exclusive and the end of the interval ']' is inclusive.



**Figure 6: Kaplan Meier Curve – Freedom from Ipsilateral Stroke (31 to 365 Days)**

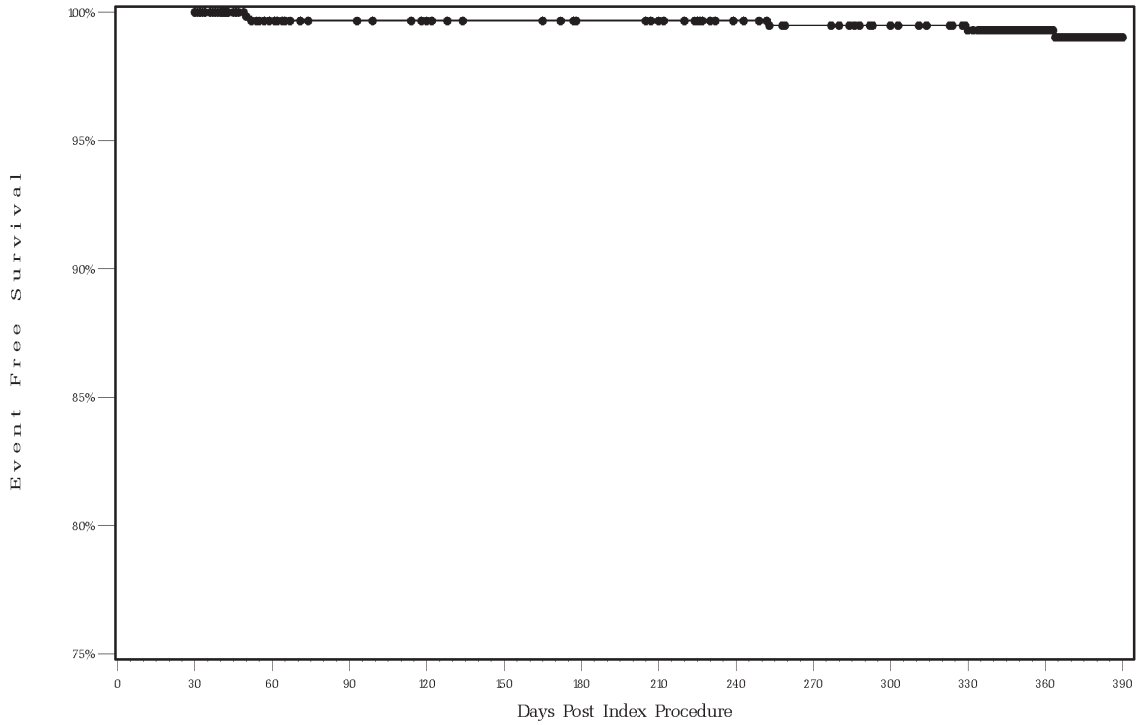

Days After Index Procedure	31	(31, 60]	(60, 180]	(180, 365]
# At Risk	629	627	589	569
# Censored	2	36	20	233
# Events	0	2	0	3
% Event Free	100%	99.7%	99.7%	99.0%
% Standard Error	0.0%	0.2%	0.2%	0.4%

Source: \\ASE\Rept2008-02\vpqm\exact\_surv\_curve May 13, 2008 (15:46)

**Note:** # At Risk gives the number of patients at risk of an event at the start of the interval, while # Censored and # Events are the incremental counts of patients censored or with events during the interval. The intervals are denoted as half-open bracket expression, where the start of interval '(' is exclusive and the end of the interval ']' is inclusive.

## Device Success

There were a total of 2,196 cases in which at least one Emboshield EPS was used and a total of 2,239 cases where at least one XACT stent was used. The device success rate was 98.5% for the Emboshield EPS and was 99.3% for the XACT stent.

**Table 14: Device Success (N = 2,232)**

	<b>N = 2232 pts M = 2293 cases*</b>
<b>Emboshield Success**</b>	98.5% (2162/2196) [97.8%, 98.9%]
<b>XACT Success***</b>	99.3% (2224/2239) [98.9%, 99.6%]

\* Bilateral procedures performed on the same day are counted as two cases, whereas same-side procedures performed on the same day are counted as one case. XACT stent information was not available for 54 cases.

The denominators represent cases in which an attempt was made to place an Emboshield or a XACT in an ICA/CCA.

\*\* Emboshield Success: at least one successful Emboshield device delivery and recovery  
Embolic protection other than Emboshield was used in 81 cases, Embolic protection was not used in 13 cases and Embolic protection data was unknown for 3 cases.

\*\*\* XACT Success: at least one successful XACT device placement

All physicians participating in the EXACT Study completed a Physician Training Program according to their level of carotid stenting experience prior to participation in the study. A total of 250 physicians enrolled patients in the EXACT study. Of these, 18 were level 1 physicians, 126 were level 2 physicians and 106 were level 3 physicians. The criteria for determination of each physician level of experience were as follows:

- **Level 1:** Performed at least 25 CAS procedures as primary operator, at least 5 procedures using Emboshield system
- **Level 2:** Investigator in a PMA CAS trial; primary operator in at least 5 CAS procedures
- **Level 3:** Adequate Interventional Experience:
  - Qualified through industry sponsored CAS program and primary operator in at least 10 procedures
  - Performed at least 25 CAS procedures as Primary or secondary operator, at least 10 procedures as primary operator
  - Performed at least 25 selective carotid angiograms-primary operator in 10 stent cases

Table 15 presents the primary endpoint events for the three levels of physician experience.

**Table 15: Hierarchical Safety Event Rates ≤ 30 days by Physician Training Level**

	<b>Physician Level 1 (N = 409 pts)</b>	<b>Physician Level 2 (N = 1061 pts)</b>	<b>Physician Level 3 (N = 675 pts)</b>
<b>All Death, Stroke, and MI*</b> [95% Conf. Interval] <sup>1</sup>	4.6% [ 2.8%, 7.2%]	4.1% [ 2.9%, 5.4%]	4.0% [ 2.7%, 5.8%]
<b>Death</b>	6	10	3
<b>All Stroke</b>	13	31	24
<b>Major Stroke</b>	3	6	5
Ipsilateral to Treated Hemisphere	3	4	5
Non- Ipsilateral to Treated Hemisphere	0	2	0
<b>Minor Stroke</b>	10	25	19
Ipsilateral to Treated Hemisphere	10	21	17
Non- Ipsilateral to Treated Hemisphere	0	4	2
<b>MI</b>	0	2	0
<b>All Stroke, Death</b> [95% Conf. Interval] <sup>1</sup>	4.6% [ 2.8%, 7.2%]	3.9% [ 2.8%, 5.2%]	4.0% [ 2.7%, 5.8%]
<b>Major Stroke, Death</b> [95% Conf. Interval] <sup>1</sup>	2.2% [ 1.0%, 4.1%]	1.5% [ 0.9%, 2.4%]	1.2% [ 0.5%, 2.3%]

\*Includes only the most serious event for each subject and includes only each subject's first occurrence of each event.

<sup>1</sup>Clopper-Pearson exact confidence interval.

There were no unanticipated adverse device effects (UADE) identified during the study. A UADE was defined as a serious adverse effect on health, safety or any life-threatening problem or death caused by, or associated with the study device. Surgery for device removal was reported once, making this event rare but not unanticipated.

### 7.3 PROTECT Post-Approval Study

#### Study Design

The PROTECT study was a prospective, non-randomized, multi-center, single arm trial initiated after the approval of the XACT Carotid Stent System. Subjects were followed at 30 days, 12 months post index procedure and annually thereafter for a total of three years. A total of 322 subjects were enrolled in the PROTECT study at 38 clinical sites in the United States. The first subject was enrolled on November 29, 2006 and enrollment was completed on June 18, 2008. The XACT stent was used in 317 of the 322 subjects enrolled. A total of five (5) subjects of the 322 subjects enrolled did not receive the XACT Stent and were

considered “treatment failures”. Per protocol, subjects classified as “treatment failures” fulfilled their study follow-up at the 30-day evaluation and were not included in the long-term phase of the study through three (3) years.

Two hundred and forty-two (242) subjects completed their three (3) year follow-up. Fifty (50) subjects expired. Eighteen (18) subjects withdrew consent from further study follow-up. Seven (7) subjects were confirmed lost to follow-up or follow-up unknown. The final three-year follow-up compliance rate of the 249 subjects eligible to return for their three-year visit is 97.2% (242/249).

Final follow-up compliance at 30-days was 100% (320/320); at one year was 98.6% (282/286); at two years was 95.9% (258/269).

## **Study Objective**

In accordance with the PMA conditions of approval of the XACT Rapid Exchange Carotid Stent System (XACT Stent), the PROTECT study was initiated to evaluate the long-term safety and efficacy of the XACT Rapid Exchange Carotid Stent System used in conjunction with the Emboshield Pro Rapid Exchange Embolic Protection System (Generation 5) and the Emboshield BareWire Rapid Exchange Embolic Protection System (Generation 3), in the treatment of atherosclerotic carotid artery disease in high-surgical risk subjects.

Subjects included in this study had a carotid artery stenosis determined by ultrasound or angiography (visual estimate) to be  $\geq 50\%$  for symptomatic subjects or  $\geq 80\%$  for asymptomatic subjects.

## **Study Endpoints**

The primary endpoint is a composite of any death, stroke and myocardial infarction (DSMI) at 30 days plus fatal and non-fatal ipsilateral stroke between 31 to 365 days and annually; thereafter, for a total of three (3) years.

The secondary endpoints for this study include:

- Acute device success
- Procedural success at 30 days
- Composite of any transient ischemic attack (TIA) and amaurosis fugax at 30 days
- Annual rate of clinically driven target lesion revascularization (TLR) through three (3) years.

## Results

### Baseline and Post-procedure Characteristics

Refer to **Tables 16 – 17** for baseline demographics and summary of high risk inclusion criteria.

**Table 16: Baseline Demographics**

	<b>N = 322</b>
<b>Age (year)</b>	
Mean ± SD (n)	72.7 ± 9.8 (322)
Median	73.6
Range (min, max)	(39.8, 92.6)
[95% confidence interval] <sup>1</sup>	[71.63, 73.78]
<b>Age ≥ 80 years</b>	30.1% (97/322)
[95% confidence interval] <sup>2</sup>	[25.16%, 35.46%]
<b>Gender</b>	
Male	64.3% (207/322)
[95% confidence interval] <sup>2</sup>	[58.78%, 69.52%]
<b>Symptomatic</b>	11.6% (37/318)
[95% confidence interval] <sup>2</sup>	[8.33%, 15.68%]
<b>Current smoker</b>	16.8% (54/322)
[95% confidence interval] <sup>2</sup>	[12.86%, 21.31%]
<b>Coronary artery disease</b>	73.3% (236/322)
[95% confidence interval] <sup>2</sup>	[68.10%, 78.05%]
<b>Previous MI</b>	30.7% (99/322)
[95% confidence interval] <sup>2</sup>	[25.75%, 36.10%]
<b>Congestive heart failure</b>	18.3% (59/322)
[95% confidence interval] <sup>2</sup>	[14.25%, 22.99%]
<b>Known left ventricular dysfunction</b>	24.5% (79/322)
[95% confidence interval] <sup>2</sup>	[19.93%, 29.61%]
<b>Hyperlipidemia requiring medication</b>	87.0% (280/322)
[95% confidence interval] <sup>2</sup>	[82.78%, 90.44%]
<b>Hypertension requiring medication</b>	87.9% (283/322)
[95% confidence interval] <sup>2</sup>	[83.82%, 91.24%]
<b>History of cardiac arrhythmia</b>	19.9% (64/322)
[95% confidence interval] <sup>2</sup>	[15.66%, 24.66%]
<b>Aortic or mitral valvular disease</b>	14.3% (46/322)
[95% confidence interval] <sup>2</sup>	[10.65%, 18.59%]

<sup>1</sup> By normal approximation method.

<sup>2</sup> By Clopper-Pearson exact method.

**Note:** Four (4) subject symptomatic statuses could not be determined due to insufficient data.

**Table 16: Baseline Demographics (continued)**

	<b>N = 322</b>
<b>Previous carotid endarterectomy</b> [95% confidence interval] <sup>2</sup>	24.5% (79/322) [19.93%, 29.61%]
<b>Current contralateral disease</b> [95% confidence interval] <sup>2</sup>	56.2% (181/322) [50.60%, 61.71%]
<b>History of peripheral vascular disease</b> [95% confidence interval] <sup>2</sup>	38.5% (124/322) [33.17%, 44.07%]
<b>Previous valve replacement</b> [95% confidence interval] <sup>2</sup>	1.9% (6/322) [0.69%, 4.01%]
<b>Previous CABG</b> [95% confidence interval] <sup>2</sup>	30.1% (97/322) [25.16%, 35.46%]
<b>History of TIA</b> [95% confidence interval] <sup>2</sup>	17.4% (56/322) [13.41%, 21.98%]
<b>History of stroke</b> [95% confidence interval] <sup>2</sup>	17.1% (55/322) [13.13%, 21.65%]
<b>History of amaurosis fugax</b> [95% confidence interval] <sup>2</sup>	8.1% (26/322) [5.34%, 11.61%]
<b>Clinical COPD</b> [95% confidence interval] <sup>2</sup>	18.3% (59/322) [14.25%, 22.99%]
<b>History of renal failure</b> [95% confidence interval] <sup>2</sup>	3.1% (10/322) [1.50%, 5.64%]
<b>History of renal insufficiency</b> [95% confidence interval] <sup>2</sup>	21.1% (68/322) [16.79%, 25.99%]
<b>Diabetes requiring medication</b> [95% confidence interval] <sup>2</sup>	30.1% (97/322) [25.16%, 35.46%]
<b>History of liver failure with bleeding diathesis</b> [95% confidence interval] <sup>2</sup>	0.0% (0/322) [0.00%, 1.14%]
<b>History of GI bleeding</b> [95% confidence interval] <sup>2</sup>	8.7% (28/322) [5.86%, 12.32%]

<sup>1</sup> By normal approximation method.

<sup>2</sup> By Clopper-Pearson exact method.

**Note:** Four (4) subject symptomatic statuses could not be determined due to insufficient data.

**Table 17: Summary of High Risk Inclusion Criteria**

	<b>N = 322</b>
<b>Anatomic risk factors</b>	
<b>Previous radiation treatment to the neck or radical neck dissection</b> [95% confidence interval] <sup>1</sup>	8.4% (27/322) [5.60%, 11.97%]
<b>Target lesion at or above the second vertebral body C2</b> [95% confidence interval] <sup>1</sup>	6.8% (22/322) [4.33%, 10.16%]
<b>Inability to extend the head due to cervical arthritis or other cervical disorders</b> [95% confidence interval] <sup>1</sup>	6.5% (21/322) [4.08%, 9.80%]
<b>Tracheostomy or tracheal stoma</b> [95% confidence interval] <sup>1</sup>	1.6% (5/322) [0.51%, 3.59%]
<b>Laryngectomy</b> [95% confidence interval] <sup>1</sup>	0.3% (1/322) [0.01%, 1.72%]
<b>Contralateral laryngeal nerve palsy</b> [95% confidence interval] <sup>1</sup>	0.0% (0/322) [0.00%, 1.14%]
<b>Severe tandem lesions</b> [95% confidence interval] <sup>1</sup>	0.3% (1/322) [0.01%, 1.72%]
<b>Previous carotid endarterectomy with significant restenosis</b> [95% confidence interval] <sup>1</sup>	18.3% (59/322) [14.25%, 22.99%]
<b>Co-morbid risk factors</b>	
<b>Total occlusion of the contralateral carotid artery</b> [95% confidence interval] <sup>1</sup>	11.8% (38/322) [8.49%, 15.84%]
<b>Left ventricular ejection fraction &lt; 35%</b> [95% confidence interval] <sup>1</sup>	9.0% (29/322) [6.11%, 12.68%]
<b>Congestive NYHA functional class III or higher</b> [95% confidence interval] <sup>1</sup>	5.3% (17/322) [3.11%, 8.32%]
<b>Dialysis dependent renal failure</b> [95% confidence interval] <sup>1</sup>	0.6% (2/322) [0.08%, 2.23%]
<b>Angina CCS classification III or higher, or unstable angina</b> [95% confidence interval] <sup>1</sup>	6.8% (22/322) [4.33%, 10.16%]
<b>Requires coronary artery bypass surgery, cardiac valve surgery, peripheral vascular surgery, or abnormal aortic aneurysm repair within 60 days</b> [95% confidence interval] <sup>1</sup>	5.9% (19/322) [3.59%, 9.06%]
<b>≥ 80 years</b> [95% confidence interval] <sup>1</sup>	30.1% (97/322) [25.16%, 35.46%]
<b>Myocardial infarction within previous 6 weeks</b> [95% confidence interval] <sup>1</sup>	2.5% (8/322) [1.08%, 4.84%]
<b>Abnormal stress test</b> [95% confidence interval] <sup>1</sup>	15.2% (49/322) [11.47%, 19.61%]
<b>Severe pulmonary disease</b> [95% confidence interval] <sup>1</sup>	5.9% (19/322) [3.59%, 9.06%]
<b>Summary</b>	
<b>Subject had only anatomic risk factor(s)</b> [95% confidence interval] <sup>1</sup>	27.0% (87/322) [22.24%, 32.22%]
<b>Subject had only co-morbid risk factor(s)</b> [95% confidence interval] <sup>1</sup>	60.9% (196/322) [55.30%, 66.23%]
<b>Subject had both anatomic and co-morbid risk factors</b> [95% confidence interval] <sup>1</sup>	12.1% (39/322) [8.76%, 16.18%]

<sup>1</sup> By Clopper-Pearson exact method.

### 30-day Primary Endpoint Events

Of the total 322 subjects enrolled, 11 subjects had primary endpoint events that occurred within 30 days of the procedure and were adjudicated by the Clinical Events Committee (CEC).

The 30-day primary endpoint rate of composite DSMI is 3.4% (11/322). The combined death and stroke rate is 2.5% (8/322). Refer to **Tables 18 – 19** for 30 day primary endpoint event rates.

**Table 18: Hierarchical Summary of Death, Stroke or MI Primary Endpoint Events ≤ 30 Days (Intent-to-Treat Population)**

	N = 322
<b>Death, stroke or MI</b> [95% confidence interval] <sup>1</sup>	3.4% (11/322) [1.72%, 6.03%]
<b>Death</b>	1
<b>Stroke</b>	7
<b>Major stroke</b>	1
<b>Ipsilateral</b>	1
<b>Non-ipsilateral</b>	0
<b>Minor stroke</b>	6
<b>Ipsilateral</b>	6
<b>Non-ipsilateral</b>	0
<b>MI</b>	3
<b>Death or stroke</b> [95% confidence interval] <sup>1</sup>	2.5% (8/322) [1.08%, 4.84%]
<b>Death or major stroke</b> [95% confidence interval] <sup>1</sup>	0.6% (2/322) [0.08%, 2.23%]

<sup>1</sup> By Clopper-Pearson exact method.

**Note:** Includes only the most serious event for each subject and includes only each subject's first occurrence of the event.



As shown in **Table 19** below, stroke occurred in 2.5% (8/322) of subjects. Two (2) subjects (0.6%) experienced a major ipsilateral stroke, including one subject who had a major ipsilateral hemorrhagic stroke and died within 30 days of the procedure. Three (3) subjects (0.9%) had an MI.

**Table 19: Non-Hierarchical Summary of Death, Stroke or MI Primary Endpoint Events ≤ 30 Days (Intent-to-Treat Population)**

	<b>N = 322</b>
<b>Death</b> [95% confidence interval] <sup>1</sup>	0.3% (1/322) [0.01%, 1.72%]
<b>Stroke</b> [95% confidence interval] <sup>1</sup>	2.5% (8/322) [1.08%, 4.84%]
<b>Major stroke</b> [95% confidence interval] <sup>1</sup>	0.6% (2/322) [0.08%, 2.23%]
<b>Ipsilateral</b> [95% confidence interval] <sup>1</sup>	0.6% (2/322) [0.08%, 2.23%]
<b>Non-ipsilateral</b> [95% confidence interval] <sup>1</sup>	0.0% (0/322) [0.00%, 1.14%]
<b>Minor stroke</b> [95% confidence interval] <sup>1</sup>	1.9% (6/322) [0.69%, 4.01%]
<b>Ipsilateral</b> [95% confidence interval] <sup>1</sup>	1.9% (6/322) [0.69%, 4.01%]
<b>Non-ipsilateral</b> [95% confidence interval] <sup>1</sup>	0.0% (0/322) [0.00%, 1.14%]
<b>MI</b> [95% confidence interval] <sup>1</sup>	0.9% (3/322) [0.19%, 2.70%]

<sup>1</sup> By Clopper-Pearson exact method.

**Note:** Includes only each subject's first occurrence of each event.

**Note:** One subject had a bilateral stroke and is counted in the ipsilateral stroke category.

## Long Term Primary Endpoint

**Figure 7** shows the Kaplan-Meier curve for all subjects with available data for freedom from DSMI (to 30 days) and ipsilateral stroke (31 days to 3 years) for the ITT population. The overall composite event free rate at one (1) year is 96.6%, at two (2) years is 95.9% and at three (3) years is 95.5%. If a subject experienced multiple events, time to the first primary endpoint event is used in the analysis. Of the 322 subjects, 11 subjects had primary endpoint events which occurred within 30 days, one (1) subject had a major ipsilateral stroke on day 366, and two (2) subjects had minor ipsilateral strokes on day 654 post procedure and day 869 post procedure, respectively.

**Figure 7: Freedom From DSMI (to 30 Days) or Ipsilateral Stroke (31 Days to 3 Years) (Intent-to-Treat Population)**

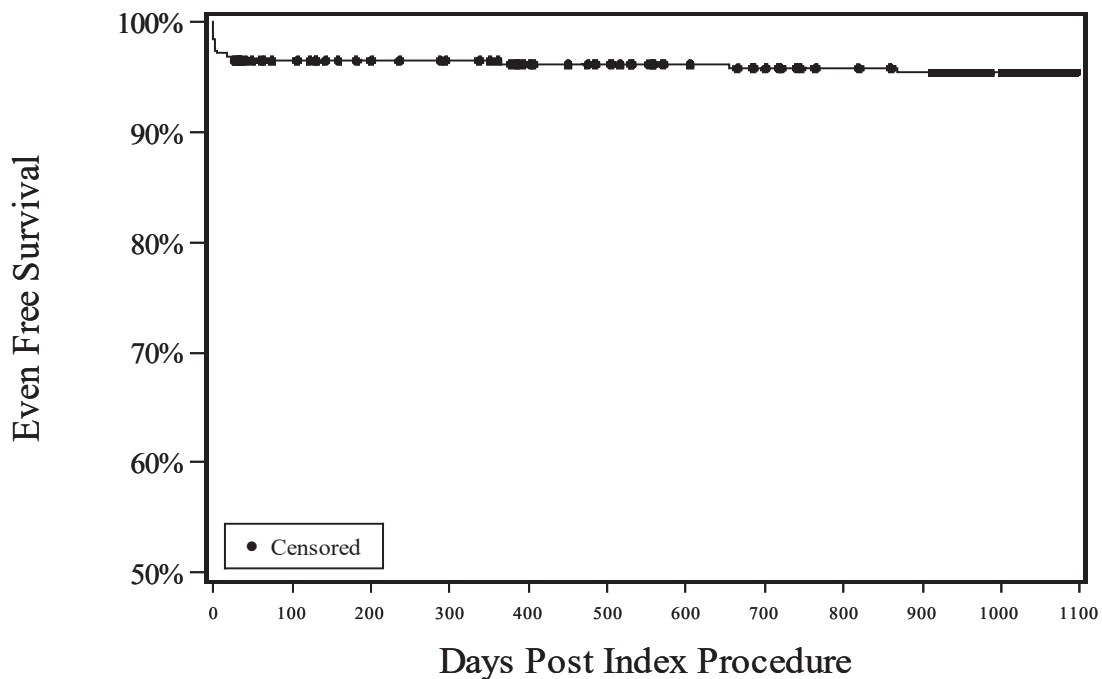

Days Post Index Procedure	0	(0, 30]	(30, 180]	(180, 365]	(365, 730]	(730, 1095]
Number at Risk	322	317	309	291	283	258
Number Censored	0	2	18	8	23	257
Number of Events	5	6	0	0	2	1
Event Free (%)	98.4%	96.6%	96.6%	96.6%	95.9%	95.5%
Standard Error (%)	0.7%	1.0%	1.0%	1.0%	1.1%	1.2%

**Note:** Number At Risk gives the number of patients at risk of an event at the start of the interval, while Number Censored and Number of Events are the incremental counts of patients censored or with events during the interval. The intervals are denoted as half-open bracket expression, where the start of interval '(' is exclusive and the end of the interval ']' is inclusive.

**Figure 8** shows the Kaplan-Meier curve for all subjects with available data for freedom from ipsilateral stroke between 31 days and three (3) years in the ITT population. The event free rate at one (1) year (365 days) is 100.0%, at two (2) years (730 days) is 99.3% and at three (3) years (1095 days) is 98.9%.

**Figure 8: Freedom From Ipsilateral Stroke between 31 Days and 3 Years (Intent-to-Treat Population)**

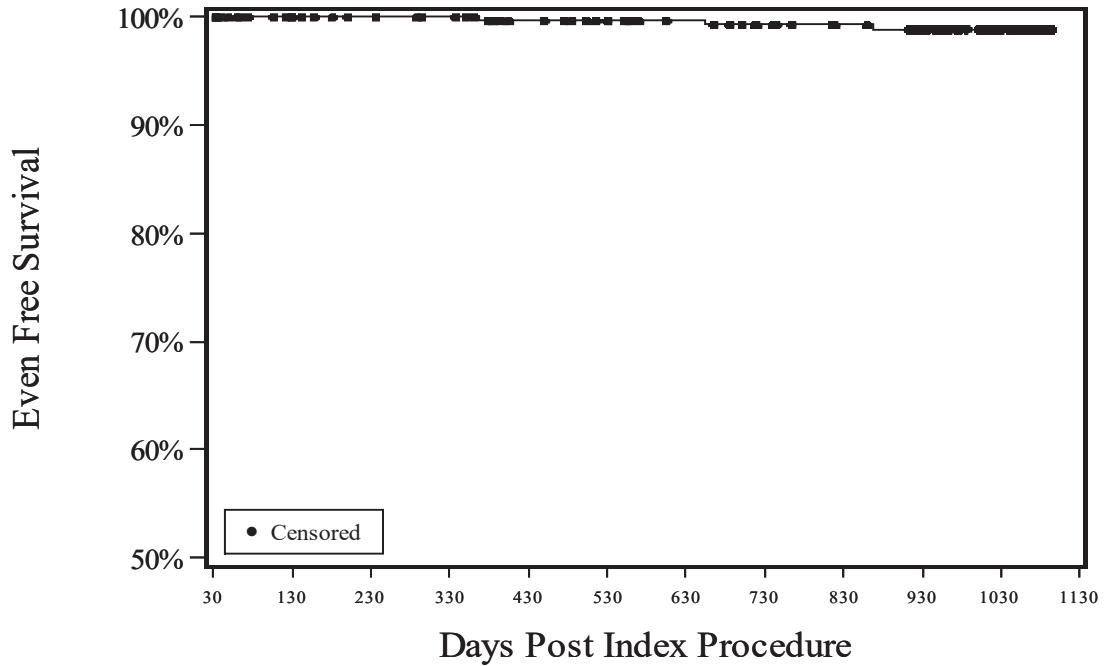

Days Post Index Procedure	31	(31, 180]	(180, 365]	(365, 730]	(730, 1095]
Number at Risk	315	315	300	292	267
Number Censored	0	15	8	23	266
Number of Events	0	0	0	2	1
Event Free (%)	100%	100%	100%	99.3%	98.9%
Standard Error (%)	0.0%	0.0%	0.0%	0.5%	0.6%

**Note:** Number At Risk gives the number of patients at risk of an event at the start of the interval, while Number Censored and Number of Events are the incremental counts of patients censored or with events during the interval. The intervals are denoted as half-open bracket expression, where the start of interval '(' is exclusive and the end of the interval ']' is inclusive.

## Long Term Primary Endpoint by Age Category

**Figure 9** shows the Kaplan-Meier curve for all subjects with available data for freedom from DSMI (to 30 days) and ipsilateral stroke (31 days to 3 years) by age category for the ITT population. The event free rate for the octogenarian subgroup (N = 97) at one (1) year (365 days) is 91.8%, at two (2) years (730 days) is 90.5% and at three (3) years (1095 days) is 90.5%. The event free rate for subjects under 80 (non-octogenarian subgroup; N = 225) at one (1) year is 98.7%, at two (2) years is 98.2% and at three (3) years is 97.6%. The event free rates between the octogenarian and non-octogenarian subgroups are clinically significant with p-values < 0.05.

**Figure 9: Freedom From DSMI (to 30 Days) or Ipsilateral Stroke (31 Days to 3 Years) (Intent-to-Treat Population)**

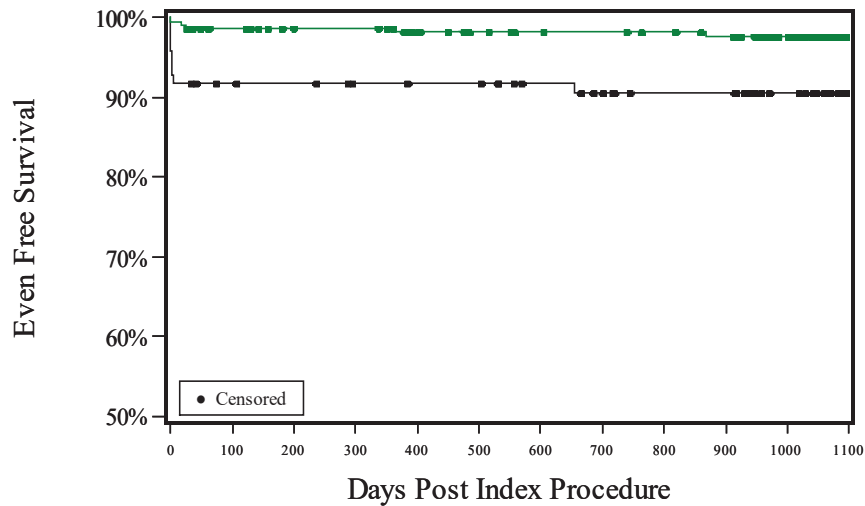

Black line: Octogenarian (n = 97)  
Green line: Non-Octogenarian (n = 225)

Days Post Index	0	(0, 30]	(30, 180]	(180, 365]	(365, 730]	(730, 1095]
<b>Octogenarian</b>						
Number at Risk	97	93	89	85	82	70
Number Censored	0	0	4	3	11	70
Number of Events	4	4	0	0	1	0
Event Free (%)	95.9%	91.8%	91.8%	91.8%	90.5%	90.5%
Standard Error (%)	2.0%	2.8%	2.8%	2.8%	3.0%	3.0%
<b>Non-Octogenarian</b>						
Number at Risk	225	224	220	206	201	188
Number Censored	0	2	14	5	12	187
Number of Events	1	2	0	0	1	1
Event Free (%)	99.6%	98.7%	98.7%	98.7%	98.2%	97.6%
Standard Error (%)	0.4%	0.8%	0.8%	0.8%	0.9%	1.0%
<b>Tests Between Groups</b>						
	Test	Chi-Square	DF	p-value		
	Log-Rank	8.379	1	0.0038		
	Wilcoxon	8.889	1	0.0029		

**Note:** Number At Risk gives the number of patients at risk of an event at the start of the interval, while Number Censored and Number of Events are the incremental counts of patients censored or with events during the interval. The intervals are denoted as half-open bracket expression, where the start of interval '[' is exclusive and the end of the interval ']' is inclusive.

## Secondary Endpoints

Acute device success for the XACT stent is defined by the attainment of < 50% residual stenosis covering an area no longer than the original lesion treated with the stent. Placement of an additional stent to treat a dissection or procedural complication as a bailout is not considered an acute device success. XACT stent success is presented on a per subject basis.

Determination of residual stenosis is based on angiographic core lab results. If angiographic data are unreadable, the final residual stenosis reported by the site is used. The acute device success for the XACT stent was achieved in 98.7% (313/317) subjects.

Acute device success for the Emboshield Pro and Emboshield Gen 3 is defined as successful deployment and retrieval of the Emboshield before and after stent implantation in the absence of angiographic distal embolization. Each Emboshield used is included in the evaluation of success as each filter is deployed and retrieved during the stenting procedure. Emboshield Pro success was achieved in 97.3% (216/222) of filters counted. Emboshield Gen 3 success was achieved in 97.0% (98/101) of filters counted.

Procedural success is defined as the attainment of less than 50% residual stenosis (per angiographic core lab) of the target lesion and the absence of DSMI at 30 days post index procedure. Procedural success was achieved in 95.3% (307/322) subjects.

Refer to **Table 20** for acute device and procedure success.

**Table 20: Acute Device Success and Procedure Success (Intent-to-Treat Population)**

N = 322	
<b>Device success</b>	
<b>XACT stent</b> [95% confidence interval] <sup>1</sup>	98.7% (313/317) [96.80%, 99.66%]
<b>Emboshield Pro</b> [95% confidence interval] <sup>1</sup>	97.3% (216/222) [94.21%, 99.00%]
<b>Emboshield Gen3</b> [95% confidence interval] <sup>1</sup>	97.0% (98/101) [91.56%, 99.38%]
<b>Procedure success</b> [95% confidence interval] <sup>1</sup>	95.3% (307/322) [92.43%, 97.37%]

<sup>1</sup> By Clopper-Pearson exact method.

**Note:** The XACT stent and procedure success were counted per subject, and the Emboshield Pro and Emboshield Gen 3 success were counted per filter.

**Note:** Two Quantitative Coronary Angiographies were not readable by core lab when determining lesion stenosis, and the angiographic visual estimates from the sites were used.

There were ten (10) reported cases of TIA and amaurosis fugax within 30 days summarized in the ITT population presented in **Table 21**.

A composite of any TIA and amaurosis fugax at 30 days post index procedure was counted per subject. Only the first occurrence of TIA or amaurosis fugax within 30 days post index procedure was counted. These ten (10) events occurred in nine (9) subjects. One (1) subject experienced both TIA (at day 12) and amaurosis fugax (at day 5) within 30 days.

The composite rate of TIA and amaurosis fugax up to 30 days post procedure was 2.8% (9/322). Separately, TIA occurred in 2.8% (9/322) and amaurosis fugax occurred in 0.3% (1/322) of subjects.

All subjects with reported TIAs or amaurosis fugax recovered. One (1) subject who experienced a TIA required treatment with medication. The remaining eight (8) subjects recovered without treatment.

**Table 21: Non-Hierarchical Subject Counts of TIA and Amaurosis Fugax Endpoint Events ≤ 30 Days (Intent-to Treat Population)**

	N = 322
<b>TIA or Amaurosis fugax</b> [95% confidence interval] <sup>1</sup>	2.8% (9/322) [1.29%, 5.24%]
<b>TIA</b> [95% confidence interval] <sup>1</sup>	2.8% (9/322) [1.29%, 5.24%]
<b>Amaurosis fugax</b> [95% confidence interval] <sup>1</sup>	0.3% (1/322) [0.01%, 1.72%]

<sup>1</sup> By Clopper-Pearson exact method.

**Note:** Includes only each subject's first occurrence of each event.

Additionally, clinically driven target lesion revascularization (TLR) is a secondary endpoint in the PROTECT study and provides insight into the long-term durability of carotid stenting. Revascularization includes any repeat intervention procedure such as surgery, angioplasty and re-stenting to revascularize the stented target lesion in order to open or increase the luminal diameter.

TLR is designated as clinically driven if the subject has recurring symptoms or has become newly symptomatic and has stenosis ≥ 50% in the stented lesion, or is asymptomatic and has a stenosis of ≥ 80% in the stented lesion. Ultrasound and / or angiography were used to confirm the degree of restenosis. In some cases, site reported percent diameter stenosis was used to measure the degree of restenosis if follow-up angiography or ultrasound was unavailable. Freedom from clinically driven TLR within three (3) years is presented in **Figure 10**.

If a subject experienced multiple clinically indicated TLRs, time to the first endpoint event is used in the analysis. There have been six (6) identified clinically driven TLRs in five (5) subjects in the PROTECT study within three (3) years. One subject experienced two (2) clinically driven TLRs. The event free rate at one (1) year (365 days) is 99.3%, at two (2) years (730 days) is 98.2% and at three (3) years (1095 days) is 98.2%.

**Figure 10: Freedom From Clinically Driven Target Lesion Revascularization within 3 Years (Intent-to-Treat Population)**

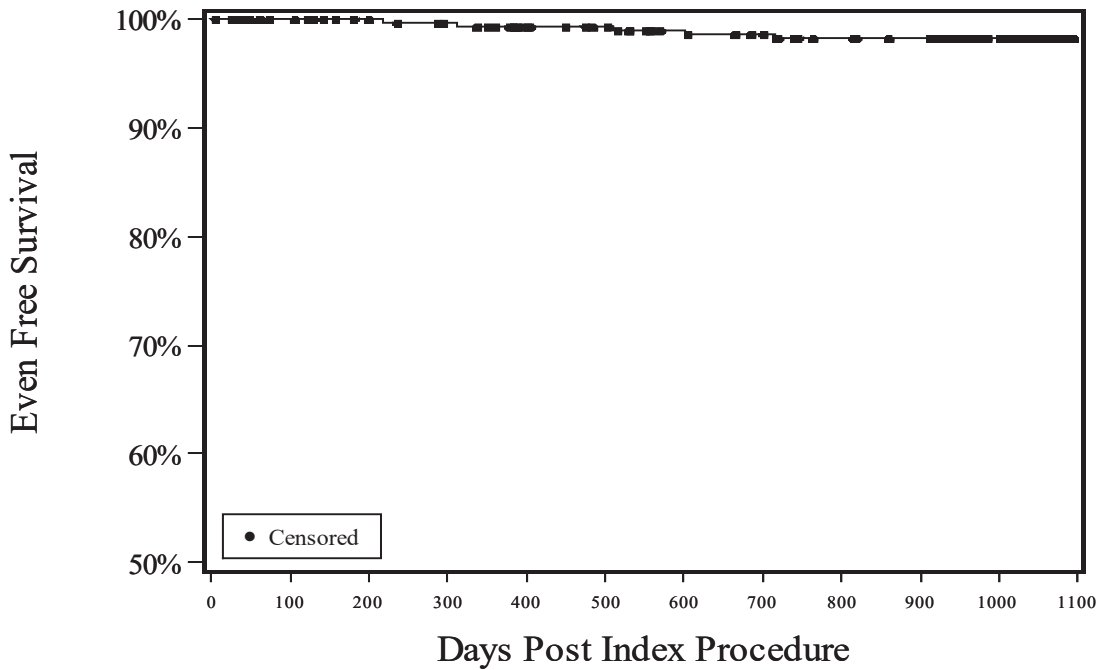

Days Post Index Procedure	0	(0, 30]	(30, 180]	(180, 365]	(365, 730]	(730, 1095]
Number at Risk	317	317	315	300	290	263
Number Censored	0	2	15	8	24	263
Number of Events	0	0	0	2	3	0
Event Free (%)	100%	100%	100%	99.3%	98.2%	98.2%
Standard Error (%)	0.0%	0.0%	0.0%	0.5%	0.8%	0.8%

**Note:** Number At Risk gives the number of patients at risk of an event at the start of the interval, while Number Censored and Number of Events are the incremental counts of patients censored or with events during the interval. The intervals are denoted as half-open bracket expression, where the start of interval '[' is exclusive and the end of the interval ']' is inclusive.

## Summary

There have been no unanticipated or rare events reported in this study.

All AEs, including possible rare AEs or possible unanticipated adverse device effects (UADEs), were evaluated on an ongoing basis. Events are considered rare if the nature, frequency and severity of the event has not been previously known to be associated with the use of the device.

The PROTECT study provides valuable long-term data with low endpoint outcomes, but is limited to a relatively small sample size of 322 subjects. The PROTECT study results continue to support that carotid artery stenting, with the XACT stent and Emboshield EPS, in patients at high risk for CEA is safe and effective through 3 year long-term follow-up.

## **7.4 XACT / ENROUTE NPS Project**

### **Objective**

The objective of the XACT / ENROUTE<sup>±</sup> Transcarotid Neuroprotection System (ENROUTE NPS) data analysis project was to assess the safety and performance of the XACT stent with the transcarotid artery revascularization (TCAR) approach with flow reversal procedure using the ENROUTE NPS, in treatment of patients with symptomatic or asymptomatic carotid artery disease in the CREST-2 Registry (C2R).

### **Data Source and Subject Disposition**

This project was a retrospective analysis of data from the C2R. Patient-level data for the XACT / ENROUTE NPS cases included the following time points: at baseline, during or immediately post-procedure, at hospital discharge and at 30 days post procedure.

From study start through cutoff date of November 18, 2022, a total of 39 C2R subjects had been treated with the XACT stent system by TCAR approach using the ENROUTE NPS. No subjects were excluded, withdrawn or censored by C2R study personnel or by Abbott. The analysis population was comprised of the complete XACT ENROUTE NPS patient cohort in the C2R study as of the cutoff date.

### **Eligibility Criteria**

Patients in C2R were required to meet one or more of the inclusion criteria and have none of the exclusion criteria listed below:

#### Inclusion Criteria

##### Asymptomatic patients

Age  $\geq 18$  and  $\leq 80$  and any one of the following:

1.  $\geq 70\%$  stenosis, standard surgical risk for CEA
2.  $\geq 70\%$  stenosis, high anatomic risk for CEA
3.  $\geq 70\%$  stenosis, high physiologic risk for CEA

##### Symptomatic patients

Symptomatic patients are defined by the following characteristics: Ipsilateral carotid Transient Ischemic Attack (TIA), with neurologic symptoms persisting less than 24 hours; Ipsilateral non-disabling stroke: Modified Rankin Scale (mRS)  $\leq 3$ ; and Ipsilateral transient monocular blindness: amaurosis fugax. [Source: current Medicare NCD for CAS]

Age  $\geq 18$  and  $\leq 80$  and any one of the following:

1.  $\geq 50\%$  stenosis, standard surgical risk for CEA
2. 50% to 69% stenosis, high anatomic risk for CEA



3. 50% to 69% stenosis, high physiologic risk
4.  $\geq 70\%$  stenosis, high anatomic and / or physiologic risk for CEA - currently covered by Medicare, but sites are strongly encouraged to voluntarily include these patients in C2R
5.  $\geq 70\%$  stenosis, post-CEA and –CAS - currently covered by Medicare, but sites are strongly encouraged to voluntarily include these patients in C2R
6.  $\geq 70\%$  stenosis, post-irradiation - currently covered by Medicare, but sites are strongly encouraged to voluntarily include these patients in C2R

#### Exclusion Criteria

1. NYHA Class IV CHF
2. COPD on chronic continuous oxygen therapy
3. Severe (Childs Class D) liver failure
4. Cancer with metastatic spread and / or undergoing active chemotherapeutic treatment
5. Any dementia considered greater than “mild”

#### **Endpoints**

There was no primary endpoint or formal hypothesis testing. Patient baseline characteristics, lesion and vessel characteristics, procedural outcomes and clinical safety outcomes were assessed using descriptive statistics. Outcomes were analyzed on an as-treated basis with no pre-defined patient censoring.

#### **Baseline Patient Demographics**

The baseline patient characteristics for the XACT / ENROUTE NPS patients are summarized in **Table 22**. For symptomatic carotid artery disease patients (N = 22), asymptomatic carotid artery disease patients (N = 17) and the overall population (N = 39), median age was 73.5 years, 70.0 years and 72.0 years, respectively. Female gender was 63.6%, 64.7% and 64.1%, respectively. There was a high prevalence of baseline hypertension (95.2%, 87.5% and 91.9%, respectively) and high surgical risk for carotid endarterectomy (CEA) (90.9%, 82.4% and 87.2%, respectively). The incidence of patients with prior CEA or CAS procedures was 22.7%, 52.9% and 35.9%, respectively.

**Table 22: Patient Baseline Characteristics (Per-Subject Analysis)**

Characteristic	Symptomatic (N=22)	Asymptomatic (N=17)	Overall (N=39)
<b>Age (years)</b>			
Mean ± SD (n)	73.6 ± 11.6 (22)	71.8 ± 7.0 (17)	72.8 ± 9.8 (39)
Median (Q1, Q3)	73.5 (63.0, 85.0)	70.0 (66.0, 78.0)	72.0 (64.0, 83.0)
Range (min, max)	(54, 90)	(61, 84)	(54, 90)
<b>Sex</b>			
Female	63.6% (14/22)	64.7% (11/17)	64.1% (25/39)
<b>Baseline Diabetes</b>	18.2% (4/22)	11.8% (2/17)	15.4% (6/39)
<b>Baseline Hypertension</b>	95.2% (20/21)	87.5% (14/16)	91.9% (34/37)
<b>Baseline CAD</b>	27.3% (6/22)	23.5% (4/17)	25.6% (10/39)
<b>Smoking History</b>			
Never	18.2% (4/22)	5.9% (1/17)	12.8% (5/39)
Prior	45.5% (10/22)	41.2% (7/17)	43.6% (17/39)
Current	36.4% (8/22)	52.9% (9/17)	43.6% (17/39)
<b>Prior CEA/CAS /</b>	22.7% (5/22)	52.9% (9/17)	35.9% (14/39)
<b>High risk for CEA</b>	90.9% (20/22)	82.4% (14/17)	87.2% (34/39)

### Baseline Anatomical Characteristics

The baseline anatomical characteristics of symptomatic patients, asymptomatic patients and the overall population of the XACT ENROUTE NPS analysis are summarized in **Table 23** on a per-lesion basis. Right side lesions comprised 34.8%, 35.0% and 34.9%, respectively, and internal carotid artery (ICA) lesion location was 56.5%, 55.0% and 55.8%, respectively. Operator assessed lesion stenosis was 85.7%, 83.8% and 84.7%, respectively, and operator assessed lesion length was 29.0 mm, 17.9 mm and 24.1 mm, respectively.

**Table 23: Patient Anatomical Characteristics (Per-Lesion Analysis)**

Characteristic	Symptomatic (N=22) (L=23)	Asymptomatic (N=17) (L=20)	Overall (N=39) (L=43)
<b>Lesion Side</b>			
Right	34.8% (8/23)	35.0% (7/20)	34.9% (15/43)
<b>Lesion Location<sup>1</sup></b>			
Bifurcation	34.8% (8/23)	35.0% (7/20)	34.9% (15/43)
CCA	8.7% (2/23)	15.0% (3/20)	11.6% (5/43)
ICA	56.5% (13/23)	55.0% (11/20)	55.8% (24/43)
<b>Lesion Stenosis (%)</b>			
Mean ± SD (I)	85.7 ± 10.6 (18)	83.8 ± 11.6 (17)	84.7 ± 11.0 (35)
Median (Q1, Q3)	87.5 (76.0, 95.0)	85.0 (80.0, 90.0)	85.0 (80.0, 91.0)
Range (min, max)	(70, 99)	(50, 99)	(50, 99)
<b>Lesion Length (mm)</b>			
Mean ± SD (I)	29.0 ± 16.3 (15)	17.9 ± 6.7 (12)	24.1 ± 13.9 (27)
Median (Q1, Q3)	30.0 (15.0, 35.0)	17.5 (11.5, 23.5)	20.0 (15.0, 30.0)
Range (min, max)	(10, 70)	(10, 30)	(10, 70)

<sup>1</sup> There can be more than one location within one lesion.

### Results

## Procedural Results

The procedural outcomes of symptomatic patients, asymptomatic patients and the overall population of the XACT ENROUTE NPS analysis are summarized in **Table 24**. Number of stents used per patient was  $1.3 \pm 0.5$ ,  $1.2 \pm 0.4$  and  $1.3 \pm 0.4$ , respectively, and total stent length was  $41.3 \pm 14.7$  mm,  $38.4 \pm 10.4$  mm and  $40.0 \pm 12.9$  mm, respectively. Flow reversal time mediated through the ENROUTE NPS Flow Controller was  $14.69 \pm 6.74$  min,  $18.42 \pm 17.55$  min and  $16.55 \pm 12.82$  min, respectively. The total procedure time ( $72.9 \pm 25.3$  min,  $113.2 \pm 62.5$  min and  $89.0 \pm 47.5$  min, respectively) and contrast volume ( $75.2 \pm 60.4$  mL,  $119.6 \pm 83.8$  mL and  $95.5 \pm 74.4$  mL, respectively) were higher for asymptomatic patients, but fluoroscopy time ( $7.8 \pm 3.9$  min,  $8.2 \pm 3.0$  min and  $8.0 \pm 3.5$  min, respectively) did not show differences across patient symptom status. Technical success, defined as ability to access the CCA, cross the lesion and deploy the stent as intended, was 100%. There were no reports of failure to remove the delivery system or the ENROUTE NPS from the patient anatomy.

**Table 24: Procedural Outcomes**

Characteristic	Symptomatic (N=22) (L=23)	Asymptomatic (N=17) (L=20)	Overall (N=39) (L=43)
<b>Per-Subject Analysis</b>			
<b>Number of Stents Used</b>			
Mean ± SD (n)	1.3 ± 0.5 (22)	1.2 ± 0.4 (17)	1.3 ± 0.4 (39)
Median (Q1, Q3)	1.0 (1.0, 2.0)	1.0 (1.0, 1.0)	1.0 (1.0, 2.0)
Range (min, max)	(1, 2)	(1, 2)	(1, 2)
<b>Maximum Stent Diameter (mm)</b>			
Mean ± SD (n)	7.4 ± 1.2 (22)	7.2 ± 1.2 (17)	7.3 ± 1.2 (39)
Median (Q1, Q3)	7.0 (6.0, 8.0)	7.0 (6.0, 8.0)	7.0 (6.0, 8.0)
Range (min, max)	(6, 10)	(6, 10)	(6, 10)
<b>Total Stent Length (mm)</b>			
Mean ± SD (n)	41.3 ± 14.7 (22)	38.4 ± 10.4 (17)	40.0 ± 12.9 (39)
Median (Q1, Q3)	35.0 (30.0, 50.0)	40.0 (30.0, 40.0)	40.0 (30.0, 40.0)
Range (min, max)	(30, 70)	(20, 62)	(20, 70)
<b>Flow Reversal Time (min)</b>			
Mean ± SD (n)	14.69 ± 6.74 (6)	18.42 ± 17.55 (6)	16.55 ± 12.82 (12)
Median (Q1, Q3)	13.06 (12.00, 18.00)	11.75 (10.00, 19.00)	13.00 (10.25, 18.50)
Range (min, max)	(6.00, 26.00)	(5.00, 53.00)	(5.00, 53.00)
<b>Total Procedure Time (min)</b>			
Mean ± SD (n)	72.9 ± 25.3 (18)	113.2 ± 62.5 (12)	89.0 ± 47.5 (30)
Median (Q1, Q3)	68.0 (54.0, 89.0)	88.5 (79.0, 120.0)	81.0 (61.0, 99.0)
Range (min, max)	(37, 119)	(51, 258)	(37, 258)
<b>Contrast Volume (mL)</b>			
Mean ± SD (n)	75.2 ± 60.4 (19)	119.6 ± 83.8 (16)	95.5 ± 74.4 (35)
Median (Q1, Q3)	60.0 (26.0, 140.0)	125.0 (41.0, 150.0)	75.0 (30.0, 150.0)
Range (min, max)	(1, 200)	(15, 320)	(1, 320)
<b>Fluoroscopy Time (min)</b>			
Mean ± SD (n)	7.84 ± 3.89 (16)	8.21 ± 2.99 (10)	7.98 ± 3.51 (26)
Median (Q1, Q3)	7.85 (5.10, 8.70)	7.25 (5.70, 10.20)	7.65 (5.40, 9.10)
Range (min, max)	(3.9, 20.5)	(5.0, 13.7)	(3.9, 20.5)
<b>Technical Success</b>			
	100.0% (22/22)	100.0% (17/17)	100.0% (39/39)
<b>Per-Lesion Analysis</b>			
<b>Maximum Stent Diameter (mm)<sup>1</sup></b>			
Mean ± SD (1)	7.3 ± 1.2 (23)	7.1 ± 1.2 (18)	7.2 ± 1.2 (41)
Median (Q1, Q3)	7.0 (6.0, 8.0)	7.0 (6.0, 8.0)	7.0 (6.0, 8.0)
Range (min, max)	(6, 10)	(6, 10)	(6, 10)
<b>Total Stent Length (mm)<sup>1</sup></b>			
Mean ± SD (1)	39.5 ± 13.3 (23)	36.2 ± 9.0 (18)	38.0 ± 11.6 (41)
Median (Q1, Q3)	30.0 (30.0, 40.0)	40.0 (30.0, 40.0)	40.0 (30.0, 40.0)
Range (min, max)	(30, 70)	(20, 60)	(20, 70)

<sup>1</sup> Length and diameter data only available for 41/43 lesions.

**Clinical Results**

The clinical safety outcomes of symptomatic patients, asymptomatic patients and the overall population of the XACT ENROUTE NPS analysis are summarized in **Table 25** for the in-hospital period and through 30 days post-procedure. In the overall population there were a total of 4 stroke, death or myocardial infarction events occurring in 3 patients over the 30-day follow-up period. Through 30 days in the overall population, the stroke or death rate was 5.1% (2/39) and the stroke, death or myocardial infarction rate was 7.7% (3/39).

**Table 25: Safety Outcomes (Per-Subject Analysis)**

Characteristic	Symptomatic (N=22)	Asymptomatic (N=17)	Overall (N=39)
<b>In-Hospital</b>			
Stroke, Death or Myocardial Infarction	9.1% (2/22)	5.9% (1/17)	7.7% (3/39)
Stroke or Death	9.1% (2/22)	0.0% (0/17)	5.1% (2/39)
Stroke	4.5% (1/22)	0.0% (0/17)	2.6% (1/39)
Death	4.5% (1/22)	0.0% (0/17)	2.6% (1/39)
Myocardial Infarction	4.5% (1/22)	5.9% (1/17)	5.1% (2/39)
<b>0-30 Days</b>			
Stroke, Death or Myocardial Infarction	9.1% (2/22)	5.9% (1/17)	7.7% (3/39)
Stroke or Death	9.1% (2/22)	0.0% (0/17)	5.1% (2/39)
Stroke	4.5% (1/22)	0.0% (0/17)	2.6% (1/39)
Death	4.5% (1/22)	0.0% (0/17)	2.6% (1/39)
Myocardial Infarction	4.5% (1/22)	5.9% (1/17)	5.1% (2/39)

## Conclusions

In this analysis, a patient cohort of 39 subjects (22 symptomatic and 17 asymptomatic) in the C2R study were treated with the XACT stent using the TCAR procedure with the ENROUTE NPS from February 2015 to May 2022. The patients were predominantly high risk for CEA and hypertensive, and in contrast to most published studies of carotid stenting, the patient population was predominantly female. There were 3 patients who had a clinical safety event within 30 days, one of whom died at 13 days.

The findings from this experience in 39 patients appear to be representative of a carotid artery disease population, and do not suggest any concerns with safety and performance associated with use of the XACT stent with the ENROUTE NPS. Technical success was 100%, and the number of observed clinical events was low and as expected for this population.

## 8.0 CLINICIAN USE INFORMATION

**Only physicians or allied healthcare professionals under the direction of such physicians who have received appropriate training and are familiar with the principles, clinical applications, complications, side effects, and hazards commonly associated with carotid interventional procedures should use this device.**

**Warning: The XACT™ Carotid Stent System is intended for one-time use only. DO NOT resterilize and / or reuse it, as this can potentially result in compromised device performance and risk of cross-contamination.**

**Warning: Do not use the product after the Use by Date specified on the label.**

### 8.1 Materials Required

- 6 F introducer sheath or 8 F guiding catheter compatible with the vascular anatomy. Minimum guiding catheter / sheath size inner diameter (I.D.) 0.088" / 2.24 mm
- 0.096" (2.44 mm) hemostatic valve (optional)
- Balloon dilatation catheter (optional)
- 1,000 u/500 cc heparinized normal saline (sterile)
- 3 ml Luer lock syringe
- Compatible Embolic Protection System and appropriate guide wire
  - Emboshield NAV<sup>6</sup>™ Embolic Protection System and BareWire™ Filter Delivery Wire (or)
  - ENROUTE Neuroprotection System and 0.014" guide wire

## **8.2 Periprocedural Care**

During the SECURITY trial, when possible, aspirin 325 mg once a day and clopidogrel 75 mg once a day were started at least 72 hours prior to the procedure. Administration of heparin was recommended immediately after sheath placement. At a minimum, prior to any intervention to the carotid artery, all patients received 5,000 units of heparin IV / IA or an equivalent dose sufficient to achieve a target ACT of 200 to 250 seconds. After the procedure, aspirin 325 mg once a day was continued permanently, and clopidogrel 75 mg daily for four weeks.

### 8.3 Pre-Procedure

Refer to Section 8.2 of these instructions for the suggested pre-procedure pharmacological treatment regimen. The placement of the stent in a stenotic or obstructed carotid artery should be done in an angiography procedure room. Angiography should be performed to map out the extent of the lesion(s) and the collateral flow. If thrombus is present, do not proceed with stent deployment. Access vessels must be sufficiently patent or sufficiently recanalized to proceed with further intervention. Patient preparation and sterile precautions should be the same as any angioplasty procedure.

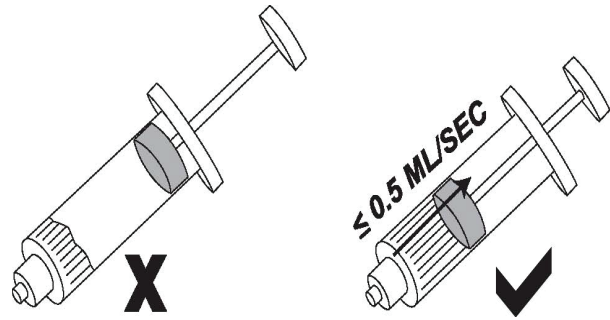

#### Using Contrast Media

During the insertion of rapid exchange catheters through guide catheters or sheaths, careful handling is required to ensure that air is not drawn into the access device. It is therefore, recommended that flushing of contrast media (or other fluids) is performed before or after insertion of the catheter, but not while the catheter is within the access device.

When a contrast media injection must be performed with the catheter in place, it is essential to ensure that no air is present within the access device before injection. This risk will be minimized by following the instructions of slow catheter insertion and good hemostatic valve control.

If aspiration is to be performed prior to contrast media injection, it should be performed slowly and steadily at a rate of not more than 0.5 ml (0.5 cc) per second until it can be visually confirmed that no further air is entering the aspiration syringe.

### 8.4 Stent Sizing

See **Table 26** and **Table 27** for stent sizes and diameters and recommended reference vessel diameters for straight and tapered stents.

The XACT Carotid Stent System is provided in a range of lengths, diameters, and configurations. Care should be taken to select the most appropriately sized stent. The device range is specified in **Table 1**. The XACT Stent undergoes < 8% foreshortening during deployment.

**WARNING: The safety and effectiveness of the XACT Carotid Stent System has NOT yet been established in patients with atherosclerotic disease involving adjoining vessels (i.e., the aortic arch or ostial common carotid artery) precluding safe placement of the guiding catheter or sheath.**

**Table 26: Stent Sizing (Straight Stent)**

Reference Vessel Size	Unconstrained Stent Diameter
> 5.5 – 6.4 mm	7.0 mm
> 6.4 – 7.3 mm	8.0 mm
> 7.3 – 8.2 mm	9.0 mm
> 8.2 – 9.1 mm	10.0 mm

**Table 27: Stent Sizing (Tapered Stent)**

Lumen Diameter Range for the Proximal End	Lumen Diameter Range for the Distal End	Tapered Unconstrained Stent Diameter
> 6.4 – 7.3 mm	4.8 – 5.5 mm	8.0 – 6.0 mm
> 7.3 – 8.2 mm	> 5.5 – 6.4 mm	9.0 – 7.0 mm
> 8.2 – 9.1 mm	> 6.4 – 7.3 mm	10.0 – 8.0 mm

## 8.5 Delivery System Preparation

- Remove the pouched device from the box.
- Examine the pouch for any signs of damage to the sterile barrier.

**If it is suspected that the sterile barrier has been compromised, do not use the device and return it to the manufacturer.**

**CAUTION: Do not expose the delivery system to organic solvents (e.g., alcohol), as the device's structural integrity and / or function may be impaired.**

**The device must only be flushed using the 3 ml syringe and flushing tip provided.**

- Peel open the pouch and remove the device from the pouch, maintaining device sterility.
- Remove the device from its protection hoop by pulling the device out by the Handle. Examine the device for any damage. If any damage is observed, do not use the device and return it to the manufacturer.
- Attach the 3 ml syringe, filled with sterile heparinized saline solution, to the Flushing Tip and flush the device tip until saline exits both between the tip and the catheter shaft (**Figure 1, No. 5 and 3**) and also at the RX Guide Wire Exit Port (**Figure 1, No. 10**).
- Examine the distal end of the device to ensure that no part of the stent is exposed. Do not use the device if any portion of the stent is exposed, and return it to the manufacturer.
- If a gap between the tip and the Outer Sheath exists, rotate the Deployment Actuator in a counter-clockwise direction (opposite direction to the arrow marking on the handle) until the gap is closed (See **Figure 11**).



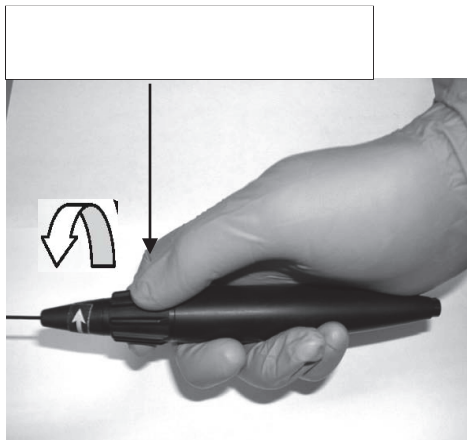

- Hold the handle as shown in **Figure 11**.
- Rotate the Deployment Actuator in the opposite direction to the arrow on the handle.

**Note:** Do not rotate the Deployment Actuator and the Handle together.

**Figure 11: Retracting the Tip**

## **8.6 Introduction of the Stent Delivery System**

**Note:** After percutaneous access is obtained, heparin should be used to maintain an ACT greater than 250 seconds.

- Access the treatment site using the appropriate accessory equipment compatible with the XACT 5.7 Fr Delivery System.

The outside diameter of the Outer Sheath is 5.7 Fr. The minimum guiding catheter / sheath size inner diameter (I.D.) required is 0.088" / 2.24 mm.

**The XACT Carotid Stent System is not to be deployed with an access device that uses an integrated leaflet-type valve.**

**Do not use a prepared XACT Carotid Stent System if the stent is not fully constrained within the Delivery System.**

Deploy the Emboshield NAV<sup>6</sup> Embolic Protection System or place the ENROUTE<sup>±</sup> Transcarotid Neuroprotection System. Other percutaneous interventional devices should be passed over the guide wire (BareWire for Emboshield NAV<sup>6</sup> Embolic Protection or any 0.014" guide wire for the ENROUTE<sup>±</sup> Transcarotid Neuroprotection System).

- If required, pre-dilate the lesion using standard angioplasty techniques over the guide wire.
- Advance the XACT Carotid Stent System over the guide wire.
- The Deployment Actuator should not be rotated before the constrained stent (within the Stent Delivery System) has been positioned at its intended deployment location. If, after preparation, a gap between the catheter tip and the outer sheath exists, rotate the Deployment Actuator in a counter-clockwise direction until the gap is closed.

**Maintain a snug seal between the device and the hemostatic valve during insertion. Failure to observe this may result in air being drawn into the access device through the**

hemostatic valve. Device insertion should be performed slowly to minimize the risk of air entrainment.

Do not advance any component of the XACT Carotid Stent System against significant resistance. The cause of any resistance should be determined via fluoroscopy and remedial action should be taken.

## 8.7 Stent Deployment

- Advance the Stent Delivery System until the radiopaque markers are appropriately positioned proximal and distal to the target lesion.

**The Deployment Actuator should not be rotated during the introduction of the Stent Delivery System.**

- Ensure that the hemostatic valve is tightened on the Stabilizer (transfemoral access only) (**Figure 1, No. 11**). Secure the Handle in one hand and ensure that the hand remains anchored to a stationary surface and does not move for the duration of the deployment. Ensure that the portion of the catheter shaft that remains outside the sheath / guide catheter is straight (**Figure 12-a**). The direction of rotation, which will initiate stent deployment, is shown by the arrow on the Handle. Slowly rotate the Deployment Actuator of the Handle in a clockwise direction (**Figure 12-b**). This rotation will initiate stent deployment.

**If Emboshield NAV<sup>6</sup> Embolic Protection System is used, allow for and maintain an adequate distance between the filter and the stent delivery system or deployed stent to avoid potential entanglement. During stent placement, 1.5 cm of vessel should be left between the distal margin of the stent and the Filtration Element. The stent delivery system should not contact the Filtration Element.**

**If ENROUTE<sup>‡</sup> Transcarotid Neuroprotection System is used, do not grip the catheter shaft section (Figure 1, No. 9) during deployment to avoid incorrect placement of the stent.**

- The Delivery System may be repositioned prior to the stent making contact with the vessel wall. The hemostatic valve must be opened prior to repositioning the stent. The hemostatic valve should be re-tightened on the Stabilizer before stent deployment is continued.

**Do not attempt to reposition the Delivery System after the stent has made contact with the vessel wall.**

- Deployment is complete when the entire stent is released and in contact with the vessel wall.
- Once the stent has made contact with the vessel wall, do not move the Delivery System until the stent has been fully deployed (**Figure 12-c**).

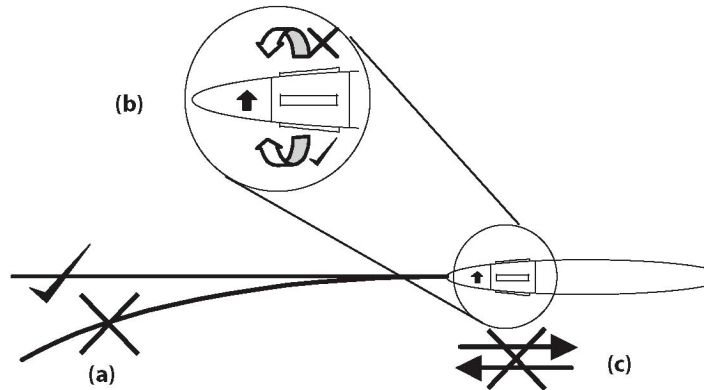

Figure 12: Stent Deployment

**CAUTION:** When more than one stent is required to cover the lesion, or if there are multiple lesions, the most distal lesion should be stented first, followed by the stenting of the proximal lesion. Stenting in this order obviates the need to cross the proximal stent for placement of the distal stent and reduces the chance of dislodging stents that have already been placed.

**CAUTION:** If an overlap of sequential stents is necessary, the amount of overlap should be kept to a minimum (approximately 5 mm). In no instance should more than 2 stents ever overlap.

**CAUTION:** Care must be exercised when crossing a newly deployed stent with other interventional devices to avoid disrupting the stent geometry and placement of the stent.

**WARNING:** Overstretching of the artery may result in rupture and life-threatening bleeding.

## 8.8 Post-deployment Stent Dilatation

- Open the hemostatic valve and withdraw the Delivery System under fluoroscopic observation.

**If any significant resistance is met during Delivery System withdrawal, the cause of any resistance should be determined via fluoroscopy, and remedial action should be taken.**

- Using fluoroscopy, assess the stent deployment.
- The stent may be post-dilated if required.

## 8.9 Post-Stent Placement

Once final angiography confirms a satisfactory result, the Emboshield System should be retrieved as per the Instructions for Use. All other ancillary devices should be removed and, if required, the puncture site closed.

## 9.0 PATIENT COUNSELING AND PATIENT INFORMATION

Physicians should review warnings, precautions, and adverse events for residual risks and possible side effects or hypersensitivity risks that may be relevant when counseling patients about use of this product and should consider the following:

- Discussion of the risk / benefit issues for this particular patient
- Discussion of alteration to current lifestyle immediately following the procedure and over the long term
- Discussion of any necessary follow up
- Discuss the risks of allergic reaction or hypersensitivity to device components

The following patient materials are provided for this product:

- A Patient Guide which includes information on carotid artery disease and the carotid stent implant procedure, is available, in United States, online at: [vascular.eIFU.abbott](http://vascular.eIFU.abbott), or by contacting customer service at 1 (800) 227-9902.
- A Stent Implant Card, including both patient information and stent implant information (provided in package).

## 10.0 HOW SUPPLIED

**Sterile:** This device is sterilized by Ethylene Oxide. Non-pyrogenic.

**Contents:** Each XACT™ Carotid Stent System contains an XACT stent premounted on a delivery system, a 3 ml Syringe, and a Flushing Tip

**Storage:** Keep dry. Keep away from sunlight.

### Disclaimer of Warranties

There is no express or implied warranty, including any implied warranty of satisfactory quality or fitness for a particular purpose, on the Emboshield Embolic Protection System described in this document. Under no circumstances shall Abbott Vascular be liable for any direct, incidental or consequential damages other than as expressly provided by specific law. Description or specifications in Abbott Vascular printed matter, including this document, are meant solely to generally describe the product at any time of manufacture and do not constitute any express warranties.

As a result of biological differences in individuals, no product is 100% effective under all circumstances. Abbott Vascular has no control over the conditions under which the device is used, diagnosis of the patient, methods of administration or its handling after the device leaves Abbott Vascular's possession. No representative of Abbott Vascular may change any of the foregoing or assume any additional liability or responsibility in connection with this device.

## 11.0 DISPOSAL

After use, this device, its accessories and packaging should be appropriately classified for disposal (e.g., biohazard, sharps, non-hazardous waste, etc.) and carefully disposed of in compliance with facility procedures and applicable laws and regulations.

Reference Abbott website for patent markings: [www.abbott.com/patents](http://www.abbott.com/patents)

™ Indicates a trademark of the Abbott group of companies.

‡ Indicates a third-party trademark, which is property of its respective owner.

© 2023 Abbott. All Rights Reserved.



**Abbott Medical**

3200 Lakeside Drive

Santa Clara, CA 95054 USA

### **CUSTOMER SERVICE**















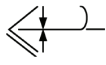

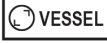



TEL: (800) 227-9902

FAX: (800) 601-8874

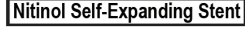
Outside USA TEL: (951) 914-4669

Outside USA FAX: (951) 914-2531

## Graphical Symbols for Medical Device Labeling

	
Catalogue number	Non-pyrogenic
	
Use-by date	Minimum Guiding Catheter
	
Batch code	Guide wire maximum diameter
	
Sterilized using ethylene oxide	Manufacturer
	
Reference vessel diameter	Date of manufacture
	
Consult instructions for use or consult electronic instructions for use	Do not use if package is damaged and consult instructions for use
	
Do not re-use	Packaging unit
	
Do not re-sterilize	MR Conditional
	
Rapid exchange	Nitinol Self-Expanding Stent
	
Keep away from sunlight	CAUTION: Federal law restricts this device to sale by or on the order of a physician
	
Keep dry	Flushing Tip
	
Unique device identifier	Syringe