

Saizen[®]
[somatotropin (rDNA origin) for injection]
For subcutaneous or intramuscular injection

DESCRIPTION

Saizen[®] [somatotropin (rDNA origin) for injection] is a human growth hormone produced by recombinant DNA technology. Saizen[®] has 191 amino acid residues and a molecular weight of 22,125 daltons. Its amino acid sequence and structure are identical to the dominant form of human pituitary growth hormone. Saizen[®] is produced by a mammalian cell line (mouse C127) that has been modified by the addition of the human growth hormone gene. Saizen[®], with the correct three-dimensional configuration, is secreted directly through the cell membrane into the cell-culture medium for collection and purification.

Saizen[®] is a highly purified preparation. Biological potency is determined by measuring the increase in body weight induced in hypophysectomized rats.

Saizen[®] is a sterile, non-pyrogenic, white, lyophilized powder intended for subcutaneous or intramuscular injection after reconstitution with Bacteriostatic Water for Injection, USP (0.9% Benzyl Alcohol). The reconstituted solution has a pH of 6.5 to 8.5.

Saizen[®] is available in 5 mg and 8.8 mg vials. The quantitative composition per vial is:

5 mg (approximately 15 IU) vial:

Each vial contains 5.0 mg somatotropin (approximately 15 IU), 34.2 mg sucrose and 1.16 mg O-phosphoric acid. The pH is adjusted with sodium hydroxide or O-phosphoric acid.

8.8 mg (approximately 26.4 IU) vial:

Each vial contains 8.8 mg somatotropin (approximately 26.4 IU), 60.2 mg sucrose and 2.05 mg O-phosphoric acid. The pH is adjusted with sodium hydroxide or O-phosphoric acid.

The diluent is Bacteriostatic Water for Injection, USP containing 0.9% Benzyl Alcohol added as an antimicrobial preservative.

Saizen[®] is also available for use with the one.click[®] auto injector pen and click.easy[®] reconstitution device. The quantitative composition per vial contained in the click.easy[®] reconstitution device is:

8.8 mg (approximately 26.4 IU) vial contained in the click.easy[®] device:

Each vial contains 8.8 mg somatotropin (approximately 26.4 IU), 60.2 mg sucrose and 2.05 mg O-phosphoric acid. The pH is adjusted with sodium hydroxide or O-phosphoric acid.

4 mg (approximately 12 IU) vial contained in the click.easy[®] device:

Each vial contains 4 mg somatropin (approximately 12 IU), 27.3 mg sucrose and 0.9 mg O-phosphoric acid. The pH is adjusted with sodium hydroxide or O-phosphoric acid.

The diluent in the click.easy[®] device contains 0.3% (w/v) metacresol in WFI added as an antimicrobial preservative.

CLINICAL PHARMACOLOGY

General

In vitro, preclinical, and clinical testing have demonstrated that Saizen[®] [somatropin (rDNA origin) for injection] is therapeutically equivalent to pituitary-derived human growth hormone. Clinical studies in normal adults also demonstrated equivalent pharmacokinetics.

Actions that have been demonstrated for Saizen[®], somatrem, and/or pituitary-derived human growth hormone include:

A. Tissue Growth-

1. **Skeletal Growth:** Saizen[®] stimulates skeletal growth in prepubertal children with pituitary growth hormone deficiency. Skeletal growth is accomplished at the epiphyseal plates at the ends of long bone. Growth and metabolism of epiphyseal plate cells are directly stimulated by growth hormone and one of its mediators, insulin-like growth factor-I. Serum levels of insulin-like growth factor-I (IGF-I) are low in children and adolescents who are growth hormone deficient, but increase during treatment with Saizen[®]. Linear growth continues until the growth plates fuse at the end of puberty.
2. **Cell Growth:** Treatment with pituitary-derived human growth hormone results in an increase in both the number and the size of skeletal muscle cells.
3. **Organ Growth:** Growth hormone of human pituitary origin influences the size and function of internal organs and increases red cell mass. Saizen[®] has been shown to promote similar organ weight increase to pituitary human growth hormone in an adequate animal model.

B. **Protein Metabolism-**Linear growth is facilitated in part by growth hormone-stimulated protein synthesis. This is reflected by increased cellular uptake of amino acids and nitrogen retention as demonstrated by a decline in urinary nitrogen excretion and blood urea nitrogen during growth hormone therapy.

C. **Carbohydrate Metabolism-**Growth hormone is a modulator of carbohydrate metabolism. Children with inadequate secretion of growth hormone sometimes experience fasting hypoglycemia that is improved by treatment with growth hormone. Saizen[®] therapy may decrease glucose tolerance. Administration of Saizen[®] to normal adults and patients with growth hormone deficiency resulted in transient increases in mean serum fasting and postprandial insulin levels. However, glucose levels remained in the normal range.

D. **Lipid Metabolism-**Acute administration of human growth hormone to humans results in lipid mobilization. Nonesterified fatty acids increase in plasma within one

hour of Saizen[®] administration. In growth hormone deficient patients, long-term growth hormone administration often decreases body fat. Mean cholesterol levels decreased in patients treated with Saizen[®]. The clinical significance of this is unknown.

- E. Mineral Metabolism- Growth hormone administration results in the retention of total body potassium, phosphorus, and sodium. Serum calcium levels appear to be unaffected.
- F. Connective Tissue/Bone Metabolism-Growth hormone stimulates the synthesis of chondroitin sulfate and collagen as well as the urinary excretion of hydroxyproline.

Pharmacokinetics

Absorption - The absolute bioavailability of recombinant human growth hormone (r-hGH) after subcutaneous administration ranges between 70-90%.

Distribution - The mean volume of distribution of r-hGH given to healthy volunteers was estimated to be 12.0 ± 1.08 L.

Metabolism - The metabolic fate of somatropin involves classical protein catabolism in both the liver and kidneys. In renal cells, at least a portion of the breakdown products is returned to the systemic circulation. The mean half-life of intravenous somatropin in normal males is 0.6 hours, whereas subcutaneously and intramuscularly administered somatropin has a half-life of 1.75 and 3.4 hours, respectively. The longer half-life observed after subcutaneous or intramuscular administration is due to slow absorption from the injection site.

Excretion - The mean clearance of intravenously administered r-hGH in six normal male volunteers was 14.6 ± 2.8 L/hr.

Special Populations

Pediatric - The pharmacokinetics of r-hGH is similar in children and adults.

Gender - No gender studies have been performed in children. In adults, the clearance of r-hGH in both men and women tends to be similar.

Race - No data are available.

Renal Insufficiency - Children and adults with chronic renal failure tend to have decreased clearance of r-hGH as compared to normals.

Hepatic Insufficiency - A reduction in r-hGH clearance has been noted in patients with hepatic dysfunction as compared with normal controls.

CLINICAL STUDIES

ADULT GROWTH HORMONE DEFICIENCY (GHD)

A multicenter, randomized, double-blind, placebo-controlled clinical trial was conducted in 115 adults with GHD comparing the effects of Saizen[®] [somatropin (rDNA origin) for injection] and placebo on body composition. Patients in the active treatment arm were treated with Saizen[®] at an initial dose of 0.005 mg/kg/day for one month which was increased to 0.01 mg/kg/day if tolerated for the remaining five months of the study. The primary endpoint was the change from baseline in lean body mass (LBM) measured by dual energy X-ray absorptiometry (DXA) after 6 months. Treatment with Saizen[®] produced significant ($p<0.001$) increases from baseline in LBM compared to placebo (Table 1).

Table 1 – Lean Body Mass (kg) by DXA

	Saizen [®] (n=52)	Placebo (n=51)
Baseline (mean)	47.7	54.0
Change from baseline at 6 months (mean)	+1.9	-0.2
Treatment difference (mean)	2.1	
95% confidence interval	(1.3, 2.9)	
p-value	<0.001	

Sixty-seven (58%) of the 115 randomized patients were male. The adjusted mean treatment difference on the increase in LBM from baseline was significantly greater in males (2.9 kg) than females (0.8 kg).

Ninety-seven (84%) of the 115 randomized patients had adult onset (AO) GHD. The adjusted mean treatment differences on the increase in LBM from baseline were not significantly different in AO GHD (2.1 kg) compared with childhood onset (CO) GHD (1.0 kg) patients. However, there were relatively few patients with CO GHD (n=18) on which to base the comparison.

Analysis of the treatment difference on the change from baseline in total fat mass (by DXA) revealed a significant decrease ($p<0.001$) in the Saizen[®]-treated group compared to the placebo group. Saizen[®] also produced beneficial effects on several bone turnover markers including bone specific alkaline phosphatase, c-terminal propeptide, osteocalcin, urine deoxypyridinoline and iPTH.

One hundred and eleven patients were enrolled in an open label follow up study and treated with Saizen[®] for an additional 6-30 months. During this period, the beneficial effects on LBM and total fat mass achieved during the initial six months of treatment were maintained.

INDICATIONS AND USAGE

Pediatric Patients - Saizen[®] [somatropin (rDNA origin) for injection] is indicated for the long-term treatment of children with growth failure due to inadequate secretion of endogenous growth hormone.

Adult Patients - Saizen[®] is indicated for replacement of endogenous growth hormone in adults with growth hormone deficiency who meet either of the following two criteria:

1. Adult Onset: Patients who have growth hormone deficiency either alone, or associated with multiple hormone deficiencies (hypopituitarism), as a result of pituitary disease, hypothalamic disease, surgery, radiation therapy, or trauma;
or
2. Childhood Onset: Patients who were growth hormone deficient during childhood who have growth hormone deficiency confirmed as an adult before replacement therapy with Saizen[®] is started.

In both of these patient populations, growth hormone deficiency should be confirmed by an appropriate growth hormone stimulation test.

CONTRAINDICATIONS

Saizen[®] is contraindicated in patients with a known hypersensitivity to somatropin or any of its excipients.

Growth hormone is contraindicated in patients with Prader-Willi syndrome who are severely obese or have severe respiratory impairment (see WARNINGS). Unless patients with Prader-Willi syndrome also have a diagnosis of growth hormone deficiency, Saizen[®] is not indicated for the long term treatment of pediatric patients who have growth failure due to genetically confirmed Prader-Willi syndrome.

In general, somatropin is contraindicated in the presence of active neoplasia. Any pre-existing neoplasia should be inactive and its treatment complete prior to instituting therapy with Saizen[®]. Saizen[®] should be discontinued if there is evidence of recurrent activity. Since growth hormone deficiency may be an early sign of the presence of a pituitary tumor (or, rarely, other brain tumors), the presence of such tumors should be ruled out prior to initiation of treatment. Saizen[®] should not be used in patients with any evidence of progression or recurrence of an underlying intracranial space-occupying lesion. Available information suggests that the rate of tumor recurrence is not increased by growth hormone therapy.

Saizen[®] should not be used for growth promotion in pediatric patients with closed epiphyses.

Saizen[®] is contraindicated in patients with proliferative or preproliferative diabetic retinopathy.

Saizen[®] reconstituted with Bacteriostatic Water for Injection, USP (0.9% Benzyl Alcohol) or diluent containing metacresol 0.3% (w/v) in WFI should not be administered to patients with a known sensitivity to Benzyl Alcohol or metacresol. (See "WARNINGS").

Growth hormone should not be initiated to treat patients with acute critical illness due to complications following open heart or abdominal surgery, multiple accidental trauma or acute respiratory failure. Two placebo-controlled clinical trials in non-growth hormone deficient adult patients (n=522) with these conditions revealed a significant increase in mortality (41.9% vs. 19.3%) among somatropin treated patients (doses 5.3-8 mg/day) compared to those receiving placebo (see "WARNINGS").

WARNINGS

There have been reports of fatalities after initiating therapy with growth hormone in pediatric patients with Prader-Willi syndrome who had one or more of the following risk factors: severe obesity, history of upper airway obstruction or sleep apnea, or unidentified respiratory infection. Male patients with one or more of these factors may be at greater risk than females. Patients with Prader-Willi syndrome should be evaluated for signs of upper airway obstruction and sleep apnea before initiation of treatment with growth hormone. If, during treatment with growth hormone, patients show signs of upper airway obstruction (including onset of or increased snoring) and/or new onset sleep apnea, treatment should be interrupted. All patients with Prader-Willi syndrome treated with growth hormone should also have effective weight control and be monitored for signs of respiratory infection, which should be diagnosed as early as possible and treated aggressively (see CONTRAINDICATIONS). Unless patients with Prader-Willi syndrome also have a diagnosis of growth hormone deficiency, Saizen[®] is not indicated for the long term treatment of pediatric patients who have growth failure due to genetically confirmed Prader-Willi syndrome.

Benzyl Alcohol as a preservative in Bacteriostatic Water for Injection, USP has been associated with toxicity in newborns. If sensitivity to the diluent occurs, Saizen[®] [somatropin (rDNA origin) for injection] may be reconstituted with Sterile Water for Injection, USP. When Saizen is reconstituted in this manner, the reconstituted solution should be used immediately and any unused solution should be discarded.

See "CONTRAINDICATIONS" for information on increased mortality in patients with acute critical illnesses in intensive care units due to complications following open heart or abdominal surgery, multiple accidental trauma or acute respiratory failure. The safety of continuing growth hormone treatment in patients receiving replacement doses for approved indications who concurrently develop these illnesses has not been established. Therefore, the potential benefit of treatment continuation with growth hormone in patients having acute critical illnesses should be weighed against the potential risk.

PRECAUTIONS

General: Saizen[®] [somatotropin (rDNA origin) for injection] therapy should be carried out under the regular guidance of a physician who is experienced in the diagnosis and management of pediatric patients with growth hormone deficiency or adult patients with either childhood-onset or adult-onset growth hormone deficiency.

Because human growth hormone may induce a state of insulin resistance, patients should be observed for evidence of glucose intolerance. Human growth hormone should be used with caution in patients with diabetes mellitus or a family history of diabetes mellitus.

Hypothyroidism may develop during Saizen[®] therapy. Untreated hypothyroidism will jeopardize the response to growth hormone. Therefore, thyroid hormone determinations should be performed periodically during Saizen[®] administration and thyroid hormone replacement should be initiated when indicated.

Intracranial hypertension (IH) with papilledema, visual changes, headache, nausea and/or vomiting has been reported in a small number of patients treated with growth hormone products and it also has been associated more commonly with IGF-I treatment. Symptoms usually occurred within the first eight weeks of the initiation of growth hormone therapy. In all reported cases, IH-associated signs and symptoms resolved rapidly after temporary suspension or termination of therapy. Funduscopic examination should be performed routinely before initiating treatment with Saizen[®] to exclude preexisting papilledema and periodically during the course of growth hormone therapy. If papilledema is observed by funduscopy during Saizen[®] treatment, treatment should be stopped. If idiopathic IH is confirmed, treatment with Saizen[®] can be restarted at a lower dose after IH-associated signs and symptoms have resolved.

When growth hormone is administered subcutaneously at the same site over a long period of time, tissue atrophy may result. This can be avoided by rotating the injection site. As for any protein, local or systemic allergic reactions may occur. Parents/Patient should be informed that such reactions are possible and that prompt medical attention should be sought if allergic reactions occur.

Pediatric Patients (see General Precautions) - Patients with endocrine disorders, including growth hormone deficiency may have an increased incidence of slipped capital femoral epiphysis. Any child who develops a limp or complains of hip or knee pain during growth hormone therapy should be evaluated.

Bone age should be monitored periodically during Saizen[®] administration especially in patients who are pubertal and/or receiving concomitant thyroid hormone replacement therapy. Under these circumstances, epiphyseal maturation may progress rapidly.

Adult Patients (see General Precautions) – Patients with epiphyseal closure who were treated with growth hormone replacement therapy in childhood should be reevaluated according to the criteria in INDICATIONS AND USAGE before continuation of somatotropin therapy at the reduced dose level recommended for growth hormone deficient adults. Fluid retention is expected during growth hormone replacement therapy in adults.

Clinical manifestations of fluid retention are usually transient and dose dependent. Experience with prolonged treatment in adults is limited.

Laboratory Tests: Serum levels of inorganic phosphorus, alkaline phosphatase, and IGF-I may increase with Saizen therapy.

Drug Interactions: Concomitant glucocorticoid therapy may inhibit the growth promoting effect of Saizen. There was no evidence in the controlled studies of the interaction of Saizen[®] with drugs commonly used in the treatment of routine pediatric problems/illnesses. Published *in vitro* data indicate that growth hormone may be an inducer of cytochrome P450 3A4. When Saizen[®] is administered in combination with drugs known to be metabolized by cytochrome P450 3A4 hepatic enzymes, it is advisable to monitor the clinical effectiveness of such drugs. However, formal drug interaction studies have not been conducted.

Carcinogenesis, Mutagenesis, Impairment of Fertility: Long-term animal studies for carcinogenicity have not been performed with Saizen. There is no evidence from animal studies to date of Saizen-induced mutagenicity or impairment of fertility.

Pregnancy: Teratogenic Effects: Pregnancy Category B. Reproduction studies have been performed in rats and rabbits at doses up to 31 and 62 times, respectively, the human (child) weekly dose based on body surface area. The results have revealed no evidence of impaired fertility or harm to the fetus due to Saizen[®]. There are, however, no adequate and well controlled studies in pregnant women. Because animal reproduction studies are not always predictive of human response, this drug should be used during pregnancy only if clearly needed.

Nursing Women: It is not known whether Saizen[®] is excreted in human milk. Because many drugs are excreted in human milk, caution should be exercised when Saizen[®] is administered to a nursing woman.

Geriatric Use: The safety and effectiveness of Saizen[®] in patients aged 65 and over has not been evaluated in clinical studies. Elderly patients may be more sensitive to the action of Saizen[®], and may be more prone to develop adverse reactions.

Information For Patients: Patients being treated with growth hormone and/or their parents should be informed of the potential benefits and risks associated with treatment. If home use is determined to be desirable by the physician, instructions on appropriate use should be given, including a review of the contents of the Patient Information Insert. This information is intended to aid in the safe and effective administration of the medication. It is not a disclosure of all possible adverse or intended effects.

If home use is prescribed, a puncture resistant container for the disposal of used syringes and needles should be recommended to the patient. Patients and/or parents should be thoroughly instructed in the importance of proper disposal and cautioned against any reuse of needles and syringes (see Patient Information Insert).

ADVERSE REACTIONS

Growth Hormone Deficient Pediatric Patients

As with all protein pharmaceuticals, a small percentage of patients may develop antibodies to the protein. Anti-growth hormone (GH) antibody capacities below 2 mg/L have not been associated with growth attenuation. In some cases when binding capacity exceeds 2 mg/L, growth attenuation has been described. In clinical studies with Saizen[®] involving 280 patients (204 naive and 76 transfer patients), one patient at 6 months of therapy developed anti-GH antibodies with binding capacities exceeding 2 mg/L. Despite the high binding capacity, these antibodies were not growth attenuating. The patient was subsequently shown to have a hGH-N gene defect. Thus, genetic analysis should be undertaken in any patient in whom anti-GH antibodies with high binding capacities occur. No antibodies against proteins of the host cells were detected in the sera of patients treated up to five years.

Any patient with well-documented growth hormone deficiency who fails to respond to therapy should be tested for antibodies to human growth hormone and for thyroid status.

In clinical studies in which Saizen[®] was administered to growth hormone deficient children, the following events were infrequently seen: local reactions at the injection site (such as pain, numbness, redness and swelling), hypothyroidism, hypoglycemia, seizures, exacerbation of preexisting psoriasis and disturbances in fluid balance.

Leukemia has been reported in a small number of growth hormone deficient patients treated with growth hormone. It is uncertain whether this increased risk is related to the pathology of growth hormone deficiency itself, growth hormone therapy, or other associated treatments such as radiation therapy for intracranial tumors. So far, epidemiological data fail to confirm the hypothesis of a relationship between growth hormone therapy and leukemia.

Growth Hormone Deficient Adult Patients

During the 6 month placebo-controlled study, adverse events were reported in 56 patients (93.3%) in the somatotropin-treated group and 42 patients (76.4%) in the placebo-treated group. Adverse events with an incidence of $\geq 5\%$ in Saizen[®]-treated patients which were more frequent in Saizen[®]-treated patients compared with placebo-treated patients are listed in Table 2. Arthralgia, myalgia, peripheral edema, other types of edema, carpal tunnel syndrome, paraesthesia and hypoaesthesia were common in the somatotropin-treated patients and reported more frequently than in the placebo group. These types of adverse events are thought to be related to the fluid accumulating effects of somatotropin. During the placebo-controlled portion of the study, approximately 10% of patients without preexisting diabetes mellitus or impaired glucose tolerance treated with somatotropin manifested mild, but persistent, abnormalities of glucose tolerance, compared with none in the placebo group. During the open label phase of the study, approximately 10% of

patients treated with somatropin required a small upward adjustment of thyroid hormone replacement therapy for preexisting central hypothyroidism and 1 patient was newly diagnosed with central hypothyroidism. In addition, during the open label phase of the study, when all patients were being treated with somatropin, two patients with preexisting central hypoadrenalism required upward titration of hydrocortisone maintenance therapy which was considered to be suboptimal (unrelated to intercurrent stress, surgery or disease), and 1 patient was diagnosed *de novo* with central adrenal insufficiency after six months of somatropin treatment. Anti-GH antibodies were not detected.

Table 2
Adverse Events with $\geq 5\%$ Overall Incidence in Saizen[®]-Treated Patients Which Were More Frequent in Saizen[®]-Treated Patients Compared with Placebo-Treated Patients During a 6 Month Study

Adverse Event	Saizen-Treated (N=60)	Placebo (N=55)
Arthralgia	14(23.3%)	7(12.7%)
Headache	11(18.3%)	8(14.5%)
Influenza-like symptoms	9(15.0%)	3(5.5%)
Edema peripheral	9(15.0%)	2(3.7)
Back pain	6(10.0%)	5(9.1%)
Myalgia	5(8.3%)	2(3.6%)
Rhinitis	5(8.3%)	2(3.6%)
Dizziness	4(6.7%)	3(5.5%)
Upper respiratory tract infection	4(6.7%)	2(3.6%)
Paraesthesia	4(6.7%)	1(1.8%)
Hypoaesthesia	4(6.7%)	0
Edema dependent	3(5.0%)	2(3.6%)
Nausea	3(5.0%)	2(3.6%)
Skeletal Pain	3(5.0%)	1(1.8%)
Carpal tunnel syndrome	3(5.0%)	1(1.8%)
Edema generalized	3(5.0%)	0
Chest pain	3(5.0%)	0
Depression	3(5.0%)	0
Hypothyroidism	3(5.0%)	0
Insomnia	3(5.0%)	0

N = number of patients

The adverse event pattern observed during the open label phase of the study was similar to the one presented above

OVERDOSAGE

Short-term overdosage could lead initially to hypoglycemia and subsequently to hyperglycemia. Moreover, overdose with somatropin is likely to cause fluid retention.

Long-term overdosage could result in signs and symptoms of gigantism and/or acromegaly consistent with the known effects of excess human growth hormone.

DOSAGE AND ADMINISTRATION

Pediatric Patients

Saizen[®] [somatropin (rDNA origin) for injection] dosage and schedule of administration should be individualized for each patient. For the treatment of growth hormone inadequacy in children, a dosage of 0.06 mg/kg (approximately 0.18 IU/kg) administered 3 times per week by subcutaneous or intramuscular injection is recommended.

Treatment with Saizen[®] of growth failure due to growth hormone deficiency should be discontinued when the epiphyses are fused. Patients who fail to respond adequately while on Saizen[®] therapy should be evaluated to determine the cause of unresponsiveness.

Adult Patients

For adult growth hormone deficient patients, the recommended dosage at the start of therapy is not more than 0.005 mg/kg/day. The dosage may be increased to not more than 0.01 mg/kg/day after 4 weeks depending upon patient tolerance of treatment. In addition to adverse effects, determination of age- and gender-adjusted serum IGF-I levels and clinical response (e.g., body composition assessments) may be used to help guide dose titration. This approach will tend to result in doses that are larger for women compared with men, and smaller for AO growth hormone deficient patients compared with CO growth hormone deficient patients as well as older and obese patients.

All Patients

To prevent possible contamination, wipe the rubber vial stopper with an antiseptic solution before puncturing it with the needle. It is recommended that Saizen[®] be administered using sterile, disposable syringes and needles. The syringes should be of small enough volume that the prescribed dose can be drawn from the vial with reasonable accuracy.

After determining the appropriate patient dose, reconstitute each vial of Saizen[®] as follows: 5 mg vial with 1-3 mL of Bacteriostatic Water for Injection, USP (Benzyl Alcohol preserved); 8.8 mg vial with 2-3 mL of Bacteriostatic Water for Injection, USP (Benzyl Alcohol preserved). For use in patients sensitive to the diluent, see "WARNINGS."

To reconstitute Saizen[®], inject the diluent into the vial of Saizen[®] aiming the liquid against the glass vial wall. Swirl the vial with a **GENTLE** rotary motion until contents are dissolved completely. **DO NOT SHAKE.** Because Saizen[®] growth hormone is a

protein, shaking can result in a cloudy solution. The Saizen[®] solution should be clear immediately after reconstitution. **DO NOT INJECT** Saizen[®] if the reconstituted product is cloudy immediately after reconstitution or refrigeration. Occasionally, after refrigeration, small colorless particles may be present in the Saizen[®] solution. This is not unusual for proteins like Saizen[®].

STABILITY AND STORAGE

Before Reconstitution - Saizen[®] [somatropin (rDNA origin) for injection] should be stored at room temperature (15°-30°C/59°-86°F). Expiration dates are stated on the labels.

After Reconstitution -When reconstituted with the diluent provided, the reconstituted solution should be stored under refrigeration (2°-8°C/36°-46°F) for up to 14 days.

Saizen[®] 8.8 mg click.easy[®] cartridge reconstituted with the diluent containing 0.3% (w/v) metacresol in WFI should be stored under refrigeration (2°-8°C/36°-46°F) for up to 21 days.

Avoid freezing reconstituted vials or cartridges of Saizen[®].

HOW SUPPLIED

Saizen can be administered using (1) a standard sterile, disposable syringe and needle, (2) a compatible Saizen[®] needle-free injection device or (3) compatible Saizen[®] needle injection device. For proper use, refer to the Instructions for Use provided with the administration.

Saizen[®] [somatropin (rDNA origin) for injection] is a sterile, non-pyrogenic, white, lyophilized powder supplied in packages containing:

1 vial of 5 mg (approximately 15 IU) Saizen[®] and 1 vial of 10 mL Bacteriostatic Water for Injection, USP (0.9% Benzyl Alcohol) NDC 44087-1005-2

1 vial of 8.8 mg (approximately 26.4 IU) Saizen[®] and 1 vial of 10 mL Bacteriostatic Water for Injection, USP (0.9% Benzyl Alcohol) NDC 44087-1088-1

1 click.easy[®] cartridge of 4 mg (approximately 12 IU, 1.5 mg/mL) Saizen[®] and 2.66 mL diluent containing 0.3% (w/v) metacresol in WFI NDC 44087-XXXX-1

5 click.easy[®] cartridges of 4 mg (approximately 12 IU, 1.5 mg/mL) Saizen[®] and 2.66 mL diluent containing 0.3% (w/v) metacresol in WFI NDC 44087-XXXX-2

1 click.easy[®] cartridge of 8.8mg (approximately 26.4 IU, 5.83 mg/mL) Saizen[®] and 1.5 mL diluent containing 0.3% (w/v) metacresol in WFI NDC 44087-1080-1

5 click.easy[®] cartridges of 8.8mg (approximately 26.4 IU, 5.83 mg/mL) Saizen[®] and 1.5 mL diluent containing 0.3% (w/v) metacresol in WFI NDC 44087-1080-2

1 click.easy[®] cartridge of 8.8 mg (approximately 26.4 IU, 8.0 mg/mL) Saizen[®] and 1.10 mL diluent containing 0.3% (w/v) metacresol in WFI NDC 44087-XXXX-1

5 click.easy[®] cartridges of 8.8 mg (approximately 26.4 IU, 8.0 mg/mL) Saizen[®] and 1.10 mL diluent containing 0.3% (w/v) metacresol in WFI NDC 44087-XXXX-2

Rx Only





May 2006

Manufactured for: Serono, Inc., Randolph, MA 02368 USA

[®] - Registered trademark of Serono, Inc., Rockland, MA 02370

Variable data

	Original text	English translation	Approved by RA
1	Batch No:	Batch No:	Date:
2	Exp. Date:	Expiry Date:	Signature:
3			
4			



**Saizen® 8.8 mg click.easy®**
[somatropin (rDNA origin) for injection]
(approximately 26.4 IU), approximately 8 mg
of drug is delivered
Manufactured for: Serono, Inc., Rockland, MA 02370, USA

Lot No: _____

Exp. Date: _____

s.c.
 **serono**

L1280101B

Variable data

	Original text	English translation	Approved by RA
1	Batch No:	Batch No:	Date:
2	Exp. Date:	Expiry Date:	Signature:
3			
4			



Saizen® 8.8 mg click.easy®

[somatropin (rDNA origin) for injection]
(approximately 26.4 IU), approximately 8 mg
of drug is delivered

Manufactured for: Serono, Inc., Rockland, MA 02370, USA

Lot No:

Exp. Date:

s.c.



L1280101B

Saizen® 8.8 mg [somatropin (rDNA) for injection]
**Reconstituted Saizen® solution for
use only with designated Saizen®
delivery devices**

This cartridge contains 5.83 mg/mL
of Saizen®



 serono

Date of reconstitution: *To be filled in by the patient*

Once reconstituted, store the cartridge in the
refrigerator (2°-8°C/36°-46°F) and use within 21
days after reconstitution. Do not freeze.

Lot No: Diluent Lot No:

Lot No:

Exp. date:



**Diluent for Saizen® 1.51 mL (0.3 % (w/v)
metacresol in Water for Injection) for
reconstitution of Saizen® 8.8 mg in the
click.easy® device.**

L6530101C

 serono

Opticlear - Noir - ETI-1241



Saizen® 8.8 mg [somatropin (rDNA) for injection]
**Reconstituted Saizen® solution for
use only with designated Saizen®
delivery devices**

This cartridge contains 5.83 mg/mL
of Saizen®



 serono

Date of reconstitution: *To be filled in by the patient*

Once reconstituted, store the cartridge in the
refrigerator (2°-8°C/36°-46°F) and use within 21
days after reconstitution. Do not freeze.

Lot No: Diluent Lot No:



Lot No:

Exp. date:



**Diluent for Saizen® 1.51 mL (0.3 % (w/v)
metacresol in Water for Injection) for
reconstitution of Saizen® 8.8 mg in the
click.easy® device.**

L 6530101C

 serono



Opticlear - Noir - ETI-1241

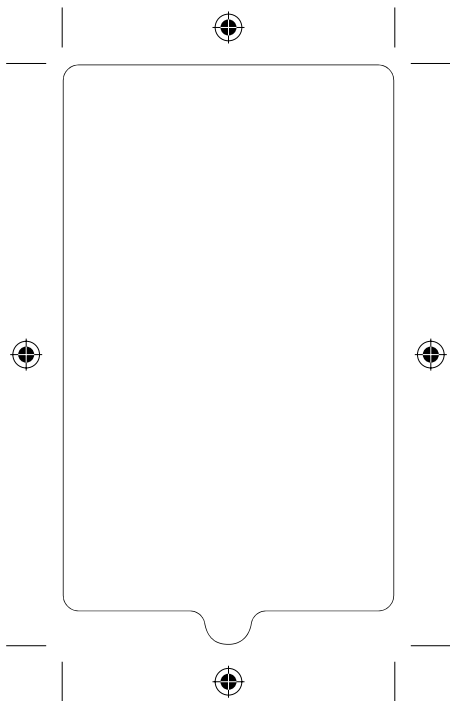

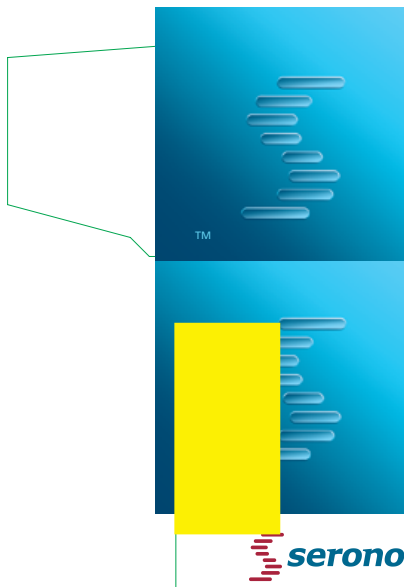

Store in original package at room temperature (15°-30°C/59°-86°F). Reconstitute before use with enclosed diluent using the click.easy® reconstitution device. See enclosed Instructions for Use. Approximately 10% mechanical loss can be associated with reconstitution and multi-dose administration. Once reconstituted, store the cartridge in the refrigerator (2°-8°C/36°-46°F) and use within 21 days after reconstitution. Do not freeze. Usual dose: See package insert. Multiple dose cartridge



S.C.

E12801018
E12801018
E12801018
E12801018
E12801018
E12801018

click.easy® Reconstitution Device

NDC 44087-1080-1

saizen® [somatotropin (rDNA origin) for injection] 8.8 mg
(approximately 26.4 IU), approximately 8 mg of the drug is delivered

Rx Only

- 1 vial somatotropin (rDNA origin)
- 1 cartridge diluent pre-assembled in 1 reconstitution device (click.easy®) including 1 device housing and 1 sterile transfer cannula
- For subcutaneous injection

Exclusively for use with designated Saizen® delivery devices

Contents:

One vial Saizen® containing 8.8 mg somatotropin (approximately 26.4 IU), 60.2 mg sucrose, 2.05 mg phosphoric acid and sodium hydroxide or phosphoric to adjust pH.

One cartridge diluent containing 1.51 mL 0.3% (w/v) metacresol in Water for Injection.



Original text		English translation		Approved by RA	
1	Lot No.:	Batch No	Expiry Date	Date:	Signature:
2	Exp. Date:				
3					
4					

Variable data

S1M
AST-1898
USA

click.easy® Reconstitution Device
saizen® [somatotropin (rDNA origin) for injection] 8.8 mg
(approximately 26.4 IU), approximately 8 mg of the drug is delivered
Lot No. _____
Exp. Date: _____



3 44087 10801 4



click.easy® Reconstitution Device
saizen® [somatotropin (rDNA origin) for injection] 8.8 mg
(approximately 26.4 IU), approximately 8 mg of the drug is delivered
Manufactured for:
Serono, Inc.
Rockland, MA 02370, USA
Made in Italy



AST-1898 Noir AST-1898 072 AST-1898 368 AST-1898 3025 AST-1898 194
AST-1898 306 AST-1898 Riserva vernice + hologram





click.easy[®] Reconstitution Device

saizen[®] [somatropin (rDNA origin) for injection] 8.8 mg

(approximately 26.4 IU), approximately 8 mg of the drug is delivered

NDC 44087-1080-2

Rx Only

- 5 vials somatropin (rDNA origin)
- 5 cartridges diluent pre-assembled in 5 reconstitution devices (click.easy[®]) including 5 device housings and 5 sterile transfer cannulas
- For subcutaneous injection

Store in original package at room temperature (15°-30°C/59°-86°F). Reconstitute before use with enclosed diluent using the click.easy[®] reconstitution device. See enclosed instructions for use. Approximately 10% mechanical loss can be associated with reconstitution and multi-dose administration. Once reconstituted, store the cartridge in the refrigerator (2°-8°C/36°-46°F) and use within 21 days after reconstitution. Do not freeze. Usual dose: See package insert. Multiple dose cartridge

S.C.

E1280102B
E1280102B
E1280102B
E1280102B
E1280102B
E1280102B

Original text		English translation		Approved by PA	
1	Lot No:	Batch No	Date:	Date:	Signature:
2	Exp. Date:	Expiry Date			
3					
4					



Exclusively for use with designated Saizen[®] delivery devices



Contents:
Five vials Saizen[®] containing 8.8 mg somatropin (approximately 26.4 IU), 60.2 mg sucrose, 2.05 mg phosphoric acid and sodium hydroxide or phosphoric to adjust pH.
Five cartridges diluent containing 1.51 mL 0.3% (w/v) metacresol in Water for Injection.

SSD
AST-1899
USA

click.easy[®] Reconstitution Device
saizen[®] [somatropin (rDNA origin) for injection] 8.8 mg
(approximately 26.4 IU), approximately 8 mg of the drug is delivered

Manufactured for:
Serono, Inc.
Rockland, MA 02370, USA
Made in Italy



3 44087 10802 1



click.easy[®] Reconstitution Device
saizen[®] [somatropin (rDNA origin) for injection] 8.8 mg
(approximately 26.4 IU), approximately 8 mg of the drug is delivered
Lot No:
Exp. Date:



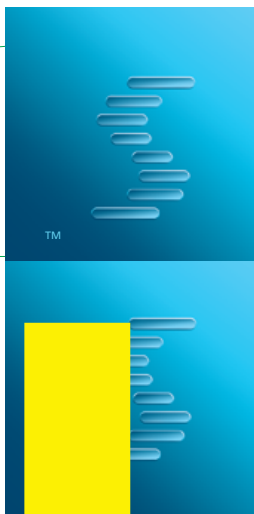

TM



Store in original package at room temperature (15°-30°C/59°-86°F). Reconstitute before use with enclosed diluent using the click.easy® reconstitution device. See enclosed Instructions for Use. Approximately 10% mechanical loss can be associated with reconstitution and multi-dose administration. Once reconstituted, store the cartridge in the refrigerator (2°-8°C/36°-46°F) and use within 21 days after reconstitution. Do not freeze. Usual dose: See package insert. Multiple dose cartridge



S.C.

E1280101B
E1280101B
E1280101B
E1280101B
E1280101B
E1280101B

click.easy® Reconstitution Device

NDC 44087-1080-1

saizen® [somatropin (rDNA origin) for injection] 8.8 mg
(approximately 26.4 IU), approximately 8 mg of the drug is delivered

Rx Only

- 1 vial somatropin (rDNA origin)
- 1 cartridge diluent pre-assembled in 1 reconstitution device (click.easy®) including 1 device housing and 1 sterile transfer cannula
- For subcutaneous injection

Exclusively for use with designated Saizen® delivery devices

Contents:

One vial Saizen® containing 8.8 mg somatropin (approximately 26.4 IU), 60.2 mg sucrose, 2.05 mg phosphoric acid and sodium hydroxide or phosphoric to adjust pH.
One cartridge diluent containing 1.51 mL 0.3% (w/v) metacresol in Water for Injection.



S1M
AST-1898
USA

Variable data

Original text	English translation	Approved by RA
1 Lot No:	Batch No	Date:
2 Exp. Date:	Expiry Date	Signature:
3		
4		

click.easy® Reconstitution Device
saizen® [somatropin (rDNA origin) for injection] 8.8 mg
(approximately 26.4 IU), approximately 8 mg of the drug is delivered

Lot No:
Exp. Date:





3 44087 10801 4



click.easy® Reconstitution Device
saizen® [somatropin (rDNA origin) for injection] 8.8 mg
(approximately 26.4 IU), approximately 8 mg of the drug is delivered

Manufactured for:
Serono, Inc.
Rockland, MA 02370, USA
Made in Italy



click.easy Reconstitution Device

Saizen®

[somatropin (rDNA origin) for injection]

INSTRUCTIONS FOR USE

For complete dosing and safety information, please refer to the Saizen® [somatropin (rDNA origin) for injection] Package Insert.

COMPOSITION

Each vial of Saizen® 8.8 mg contained in the **8.0 mg/mL click.easy®** device contains the following ingredients:

- Active substance: Somatropin (Recombinant Human Growth Hormone) 8.8 mg.
- Excipients: Sucrose, Phosphoric acid, Sodium Hydroxide; 1 mL of the reconstituted Saizen® solution contains 8.0 mg of somatropin when reconstituted with the contents of the diluent cartridge.

Each vial of Saizen® 8.8 mg contained in the **5.83 mg/mL click.easy®** device contains the following ingredients:

- Active substance: Somatropin (Recombinant Human Growth Hormone) 8.8 mg.
- Excipients: Sucrose, Phosphoric acid, Sodium Hydroxide; 1 ml of the reconstituted Saizen solution contains 5.83 mg of somatropin when reconstituted with the contents of the diluent cartridge.

Each vial of Saizen® 4 mg contained in the **1.5 mg/mL click.easy®** device contains the following ingredients:

- Active substance: Somatropin (Recombinant Human Growth Hormone) 4 mg.
- Excipients: Sucrose, Phosphoric acid, Sodium Hydroxide; 1 mL of the reconstituted Saizen® solution contains 1.5 mg of somatropin when reconstituted with the contents of the diluent cartridge.

COMPOSITION OF DILUENT

Each cartridge of diluent contained in the click.easy® reconstitution device contains the following ingredients:

8.0 mg/mL click.easy®

- Active substance: Metacresol USP (3.27 mg)
- Excipients: Phosphoric acid 85% to adjust pH, Water for Injection, USP (1.10 mL)

5.83 mg/mL click.easy®

- Active substance: Metacresol USP (4.52 mg)
- Excipients: Phosphoric acid 85% to adjust pH, Water for Injection USP (1.51 mL)

1.5 mg/mL click.easy®

- Active substance: Metacresol USP (7.91 mg)
- Excipients: Phosphoric acid 85% to adjust pH, Water for Injection, USP (2.66 mL)

Patients with a known sensitivity to any of the above active substances or excipients should avoid using this product.

PHARMACEUTICAL FORM

Powder and diluent for solution for injection: Powder and diluent (0.3% (w/v) metacresol in water for injection) for parenteral use.

METHOD AND ROUTE OF ADMINISTRATION

The product (powder in vials) must be reconstituted with the enclosed diluent (0.3% (w/v) metacresol in water for injection) using the click.easy® reconstitution device.

The reconstituted solution is intended for subcutaneous administration (under the skin) and should be clear with no particles. If the solution contains particles, it must not be injected.

IMPORTANT INFORMATION

Patients should be thoroughly instructed in the reconstitution procedure.

For young children, the reconstitution process should be supervised by an adult.

For administration of Saizen® contained in the click.easy® device, please read the following instruction carefully. Please consult your doctor or nurse or pharmacist if you have any questions concerning the reconstitution process.

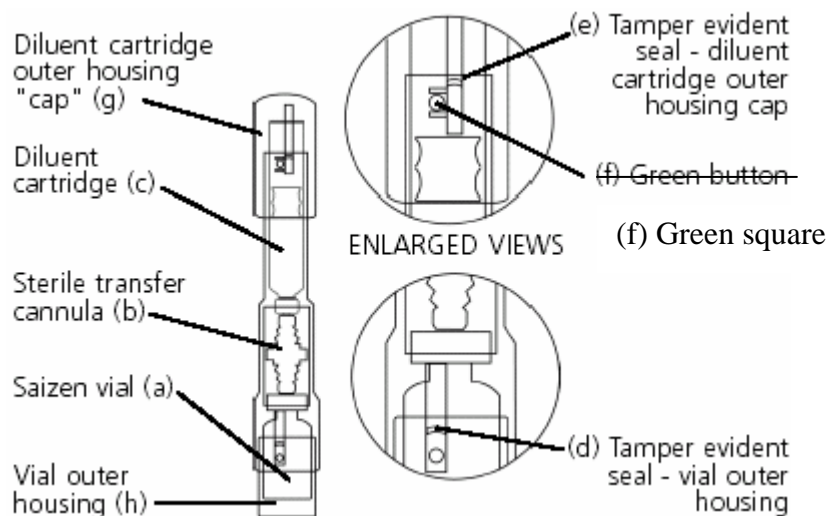

- Check that the click.easy® reconstitution device contains an unused Saizen® vial (a) and an unused diluent cartridge (c).

- Do NOT use the device if the vial or cartridge appear empty or used and return it to your pharmacist or doctor.
- Wash your hands with soap and water.

HOW TO PREPARE YOUR SOLUTION OF SAIZEN®

1. Place the click.easy® device vertically on a flat surface with the Saizen® vial on the bottom and the diluent cartridge outer housing cap (g) on top facing upward.
2. Push on the top diluent cartridge outer housing cap (g) firmly until the Saizen® vial outer housing (h) is completely inside the main body. (This step breaks the tamper evident seal on the vial.
3. Turn the diluent cartridge outer housing cap (g) clockwise until the green square (f) is visible at the lower end of the narrow rectangular opening. Push the diluent cartridge outer housing cap down very slowly until it will go no further and the green colored square appears at the upper end of the narrow rectangular opening.

Check that all the diluent has been transferred into the vial. Dissolve the Saizen® powder with the diluent by gently swirling the click.easy® device (Note: Do not transfer the diluent forcefully or shake the click.easy device. A fast transfer of the diluent or shaking of the click.easy device will create more foam). Let the solution stand for 2-5 minutes until the Saizen® powder is completely dissolved.

4. Turn the click.easy® device upside down so the Saizen® vial is now on top and pull the diluent cartridge outer housing cap slowly downwards until the solution is completely drawn back into the cartridge. Check that no more than one or two drops of solution remain in the vial.
5. If there are more than one or two drops of solution remaining in the vial, slowly push the diluent cartridge outer housing cap up until some of the solution is back in the vial and gently tap the click.easy® device. Then draw the solution slowly again back into the cartridge.
6. Remove any excess air that has been drawn into the cartridge by pushing slowly the cap up until no air bubble is visible in the cartridge. There should be no air bubble in the cartridge. (Note: Avoid pulling the cap down too fast, as this will draw air into the cartridge).
7. Turn the click.easy® device so that the cap is again on the top. Unscrew the cap and remove it.
8. Remove the cartridge containing the reconstituted Saizen® solution from the click.easy® device by grasping the end of the cartridge and pulling straight out of the outer housing.
9. Carefully peel off the outer white label on the cartridge using the tab provided by slowly pulling in the direction of the black arrow.

Sample Label

Lot No:

Exp. Date:



**Diluent for Salzen® 1.37 mL
(0.3 % (w/v) metacresol in Water
for Injection) for reconstitution
of Salzen® 8.8 mg in the
click.easy® device.**

1.51 mL

L6530101C

L6530101A



10. Write the reconstitution date on the transparent inner label on the cartridge. This cartridge now contains the reconstituted Saizen® solution that will be used for your treatment.

Sample Label

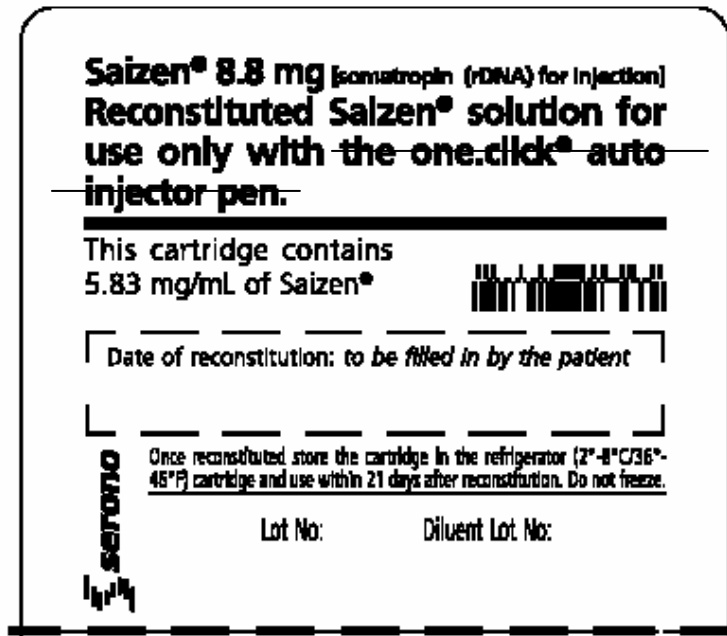

designated
Saizen delivery
devices

11. The cartridge containing the reconstituted Saizen® solution is now ready to be used (Note: Please read the instruction manual provided with the injection device for instruction on how to inject the reconstituted Saizen® solution from the cartridge).

12. The Saizen® reconstituted solution should be stored in a refrigerator (2°-8°C / 36°-46°F) and should be used within 21 days after reconstitution. Do not freeze.

13. Discard the click.easy® device containing the empty Saizen® vial safely in accordance with your local requirements. It is not necessary to remove the empty Saizen® vial from the click.easy® device prior to disposal.

Injections should be given in different parts of your body. Do not use any areas in which you feel lumps, firm knots, depressions, or pain; talk to your doctor or healthcare professional about anything you find. Clean the skin at the injection site with soap and water.

STABILITY AND STORAGE

Vials of Saizen® pre-assembled in the click.easy® reconstitution device should be stored in the original package at room temperature (15°-30°C / 59°-86°F).

Saizen® reconstituted solution should be stored in a refrigerator (2°-8°C / 36°-46°F) and should be used within 21 days after reconstitution.

Do not freeze.

HOW SUPPLIED

Saizen® contained in the click.easy® device is available in the following pack sizes:

- 1 vial of Saizen® 8.8 mg product and 1 cartridge of 1.10 mL diluent pre-assembled in 1 reconstitution device (click.easy®) comprising 1 device housing and 1 sterile transfer cannula NDC 44087-1089-1
- 5 vials of Saizen® 8.8 mg product and 5 cartridges of 1.10 mL diluent pre-assembled in 5 reconstitution devices (click.easy®) comprising each 1 device housing and 1 sterile transfer cannula NDC 44087-1089-2
- 1 vial of Saizen® 8.8 mg product and 1 cartridge of 1.51 mL diluent pre-assembled in 1 reconstitution device (click.easy®) comprising 1 device housing and 1 sterile transfer cannula.
- 5 vials of Saizen® 8.8 mg product and 5 cartridges of 1.51 mL diluent pre-assembled in 5 reconstitution devices (click.easy®) comprising each 1 device housing and 1 sterile transfer cannula.
- 1 vial of Saizen® 4 mg product and 1 cartridge of 2.66 mL diluent pre-assembled in 1 reconstitution device (click.easy®) comprising 1 device housing and 1 sterile transfer cannula NDC 44087-xxxx-x
- 5 vials of Saizen® 4 mg product and 5 cartridges of 2.66 mL diluent pre-assembled in 5 reconstitution devices (click.easy®) comprising each 1 device housing and 1 sterile transfer cannula NDC 44087-xxxx-x

Manufactured for:

Serono Inc., Rockland, MA 02370

Rx Only BX Rated

November 2006



click.easy[®] Reconstitution Device

saizen[®] [somatropin (rDNA origin) for injection] 8.8 mg

(approximately 26.4 IU), approximately 8 mg of the drug is delivered

NDC 44087-1080-2

Rx Only

- 5 vials somatropin (rDNA origin)
- 5 cartridges diluent pre-assembled in 5 reconstitution devices (click.easy[®]) including 5 device housings and 5 sterile transfer cannulas
- For subcutaneous injection

Store in original package at room temperature (15°-30°C/59°-86°F).
 Reconstitute before use with enclosed diluent using the click.easy[®]
 reconstitution device. See enclosed instructions for use.
 Approximately 10% mechanical loss can be associated with reconstitution and
 multi-dose administration.
 Once reconstituted, store the cartridge in the refrigerator (2°-8°C/36°-46°F) and
 use within 21 days after reconstitution. Do not freeze.
 Usual dose: See package insert.
 Multiple dose cartridge

S.C.

E1280102B
 E1280102B
 E1280102B
 E1280102B
 E1280102B
 E1280102B

Original text		English translation		Approved by PA	
1	Lot No:	Batch No	Date:	Date:	Signature:
2	Exp. Date:	Expiry Date			
3					
4					



Exclusively for use with designated Saizen[®] delivery devices



Contents:
 Five vials Saizen[®] containing 8.8 mg somatropin (approximately 26.4 IU), 60.2 mg sucrose, 2.05 mg phosphoric acid and sodium hydroxide or phosphoric to adjust pH.
 Five cartridges diluent containing 1.51 mL 0.3% (w/v) metacresol in Water for Injection.

SSD
 AST-1899
 USA

click.easy[®] Reconstitution Device
 saizen[®] [somatropin (rDNA origin) for injection] 8.8 mg
 (approximately 26.4 IU), approximately 8 mg of the drug is delivered
 Manufactured for:
 Serono, Inc.
 Rockland, MA 02370, USA
 Made in Italy



click.easy[®] Reconstitution Device
 saizen[®] [somatropin (rDNA origin) for injection] 8.8 mg
 (approximately 26.4 IU), approximately 8 mg of the drug is delivered
 Lot No:
 Exp. Date:

