

depo-subQ provera 104™
medroxyprogesterone acetate injectable suspension
104 mg/0.65 mL

Physician Information

Women who use depo-subQ provera 104 may lose significant bone mineral density. Bone loss is greater with increasing duration of use and may not be completely reversible.

It is unknown if use of depo-subQ provera 104 during adolescence or early adulthood, a critical period of bone accretion, will reduce peak bone mass and increase the risk for osteoporotic fracture in later life.

depo-subQ provera 104 should be used long-term (e.g., longer than 2 years) only if other methods of birth control are inadequate (see WARNINGS, section 1).

Patients should be counseled that this product does not protect against HIV infection (AIDS) and other sexually transmitted diseases.

DESCRIPTION

depo-subQ provera 104 contains medroxyprogesterone acetate (MPA), a derivative of progesterone, as its active ingredient. Medroxyprogesterone acetate is active by the parenteral and oral routes of administration. It is a white to off-white, odorless crystalline powder that is stable in air and that melts between 205° and 209°C. It is freely soluble in chloroform, soluble in acetone and dioxane, sparingly soluble in alcohol and methanol, slightly soluble in ether, and insoluble in water.

The chemical name for medroxyprogesterone acetate is 17-hydroxy-6 α -methylpregn-4-ene-3,20-dione 17-acetate. The structural formula is as follows:

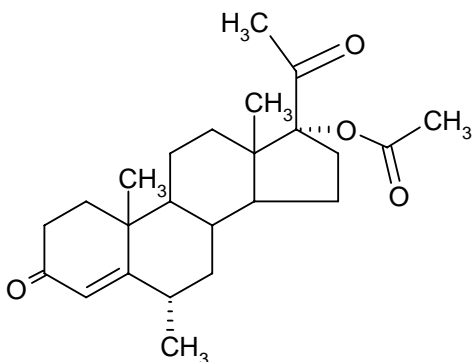

depo-subQ provera 104 for subcutaneous (SC) injection is available in pre-filled syringes (160 mg/mL), each containing 0.65 mL (104 mg) of medroxyprogesterone acetate sterile aqueous suspension.

Each 0.65 mL contains:

Medroxyprogesterone acetate	104 mg
Methylparaben	1.040 mg
Propylparaben	0.098 mg
Sodium Chloride	5.200 mg
Polyethylene Glycol	18.688 mg
Polysorbate 80	1.950 mg
Monobasic Sodium Phosphate · H ₂ O	0.451 mg
Dibasic Sodium Phosphate · 12H ₂ O	0.382 mg
Methionine	0.975 mg
Povidone	3.250 mg
Water for Injection	qs

When necessary, the pH is adjusted with sodium hydroxide or hydrochloric acid, or both.

CLINICAL PHARMACOLOGY

depo-subQ provera 104 (medroxyprogesterone acetate injectable suspension), when administered at 104 mg/0.65 mL to women every 3 months (12 to 14 weeks), inhibits the secretion of gonadotropins, which prevents follicular maturation and ovulation and causes endometrial thinning. These actions produce its contraceptive effect.

Suppression of serum estradiol concentrations and a possible direct action of depo-subQ provera 104 on the lesions of endometriosis are likely to be responsible for the therapeutic effect on endometriosis-associated pain.

Pharmacokinetics

The pharmacokinetic parameters of medroxyprogesterone acetate (MPA) following a single SC injection of depo-subQ provera 104 are shown in Table 1 and Figure 1.

**Table 1. Pharmacokinetic Parameters of MPA
after a Single SC Injection of depo-subQ provera 104 in Healthy Women
(n = 42)**

	C_{max} (ng/mL)	T_{max} (day)	C_{91} (ng/mL)	AUC_{0-91} (ng·day/mL)	$AUC_{0-\infty}$ (ng·day/mL)	$t_{1/2}$ (day)
Mean	1.56	8.8	0.402	66.98	92.84	43
Min	0.53	2.0	0.133	20.63	31.36	16
Max	3.08	80.0	0.733	139.79	162.29	114

C_{max} = peak serum concentration; T_{max} = time when C_{max} is observed; C_{91} = serum concentration at 91 days; AUC_{0-91} and $AUC_{0-\infty}$ = area under the concentration-time curve over 91 days or infinity, respectively; $t_{1/2}$ = terminal half-life

Absorption: Following a single SC injection of depo-subQ provera 104, serum MPA concentrations reach ≥ 0.2 ng/mL within 24 hours. The mean T_{max} is attained approximately 1 week after injection.

**Figure 1. Mean (SD) Serum Concentration-Time Profile of MPA
after a Single Injection of depo-subQ provera 104 to Healthy
Women**

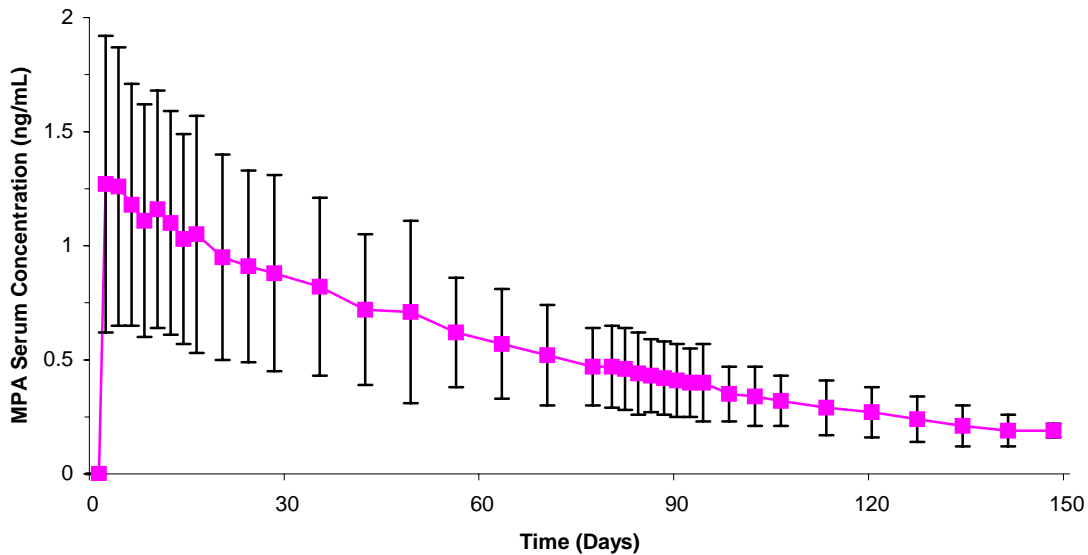

In a study to assess accumulation and the achievement of steady state following multiple SC administrations, trough concentrations of MPA were determined after 6, 12, and 24 months, and in a subset of 8 subjects, bi-weekly concentrations were determined within one dosing interval in the second year of administration. The mean (SD) MPA trough concentrations were 0.67 (0.36) ng/mL (n=157), 0.79 (0.36) ng/mL (n=144), and 0.87 (0.33) ng/mL (n=106) at 6, 12 and 24 months, respectively.

Effect of Injection Site: depo-subQ provera 104 was administered into the anterior thigh or the abdomen to evaluate effects on the MPA concentration-time profile. MPA trough concentrations (C_{\min} ; Day 91) were similar for the two injection locations.

Distribution: Plasma protein binding of MPA averages 86%. MPA binding occurs primarily to serum albumin. No binding of MPA occurs with sex-hormone-binding globulin (SHBG).

Metabolism: MPA is extensively metabolized in the liver by P450 enzymes. Its metabolism primarily involves ring A and/or side-chain reduction, loss of the acetyl group, hydroxylation in the 2-, 6-, and 21-positions or a combination of these positions, resulting in more than 10 metabolites.

Excretion: Residual MPA concentrations at the end of the first dosing interval (12 to 14 weeks) of depo-subQ provera 104 are generally below 0.5 ng/mL, consistent with its apparent terminal half-life of ~40 days after SC administration. Most MPA metabolites are excreted in the urine as glucuronide conjugates with only small amounts excreted as sulfates.

Linearity/Non-Linearity: Following a single SC administration of doses ranging from 50 to 150 mg, the AUC and C_{\min} (Day 91) increased with higher doses of depo-subQ provera 104, but there was considerable overlap across dose levels. Serum MPA concentrations at Day 91 increased in a dose proportional manner but C_{\max} did not appear to increase proportionally with increasing dose. The AUC data were suggestive of dose linearity.

Special Populations

Race: There were no significant differences in the pharmacokinetics and/or pharmacodynamics of MPA after SC administration of depo-subQ provera 104 in African-American and Caucasian women. The pharmacokinetics/pharmacodynamics of depo-subQ provera 104 were evaluated in Asian women in a separate study and also found to be similar to African-American and Caucasian women.

Effect of Body Weight: Although total MPA exposure was lower in obese women, no dosage adjustment of depo-subQ provera 104 is necessary based on body weight. The effect of body weight on the pharmacokinetics of MPA following a single dose was assessed in a subset of women ($n = 42$, body mass index [BMI] ranged from 18.2 to 46.7 kg/m^2). The AUC_{0-91} values for MPA were 71.6, 67.9, and 46.3 $\text{ng}\cdot\text{day}/\text{mL}$ in women with BMI categories of $\leq 28 \text{ kg}/\text{m}^2$, $>28-38 \text{ kg}/\text{m}^2$, and $>38 \text{ kg}/\text{m}^2$, respectively. The mean MPA C_{\max} was 1.74 ng/mL in women with $\text{BMI} \leq 28 \text{ kg}/\text{m}^2$, 1.53 ng/mL in women with $\text{BMI} >28-38 \text{ kg}/\text{m}^2$, and 1.02 ng/mL in women with $\text{BMI} > 38 \text{ kg}/\text{m}^2$, respectively. The MPA trough (C_{\min}) concentrations had a tendency to be lower in women with $\text{BMI} >38 \text{ kg}/\text{m}^2$.

Hepatic Insufficiency: No clinical studies have evaluated the effect of hepatic disease on the disposition of depo-subQ provera 104. However, steroid hormones may be poorly metabolized in patients with severe liver dysfunction (see CONTRAINDICATIONS).

Renal Insufficiency: No clinical studies have evaluated the effect of renal disease on the pharmacokinetics of depo-subQ provera 104.

Drug-Drug Interactions

See PRECAUTIONS, section 9

INDICATIONS AND USAGE

depo-subQ provera 104 is indicated for the prevention of pregnancy in women of child bearing potential.

depo-subQ provera 104 also is indicated for management of endometriosis-associated pain.

In considering use for either indication, the loss of bone mineral density (BMD) in women of all ages and the impact on peak bone mass in adolescents should be considered, along with the decrease in BMD that occurs during pregnancy and/or lactation, in the risk/benefit assessment for women who use depo-subQ provera 104 long-term (see WARNINGS, section 1).

Contraception Studies

In three clinical studies, no pregnancies were detected among 2,042 women using depo-subQ provera 104 for up to 1 year. The Pearl Index pregnancy rate in women who were less than 36 years old at baseline, based on cycles in which they used no other contraceptive methods, was 0 pregnancies per 100 women-years of use (upper 95% confidence interval = 0.25).

Pregnancy rates for various contraceptive methods are typically reported for only the first year of use and are shown in Table 2.

Table 2. Percentage of Women Experiencing an Unintended Pregnancy During the First Year of Typical Use and the First Year of Perfect Use of Contraception and the Percentage Continuing Use at the End of the First Year: United States

Method	% of Women Experiencing an Unintended Pregnancy within the First Year of Use		% of Women Continuing Use at 1 Year ³
	Typical Use ¹	Perfect Use ²	
Chance ⁴	85	85	
Spermicides ⁵	26	6	40
Periodic Abstinence	25		63
Calendar		9	
Ovulation Method		3	
Symptothermal ⁶		2	
Post-ovulation		1	
Cap ⁷			
Parous Women	40	26	42
Nulliparous Women	20	9	56
Sponge			
Parous Women	40	20	42
Nulliparous Women	20	9	56
Diaphragm ⁷	20	6	56
Withdrawal	19	4	
Condom ⁸			
Female (Reality)	21	5	56
Male	14	3	61
Pill	5		71
Progestin only		0.5	
Combined		0.1	
IUD			
Progesterone T	2.0	1.5	81
Copper T 380A	0.8	0.6	78
LNg 20	0.1	0.1	81
Depo-Provera IM 150 mg	0.3	0.3	70
Norplant and Norplant-2	0.05	0.05	88
Female Sterilization	0.5	0.5	100
Male Sterilization	0.15	0.10	100

Emergency Contraceptive Pills: Treatment initiated within 72 hours after unprotected intercourse reduces the risk of pregnancy by at least 75%.⁹

Lactational Amenorrhea Method: LAM is a highly effective, temporary method of contraception.¹⁰

Source: Hatcher et al., 1998.¹

¹Among typical couples who initiate use of a method (not necessarily for the first time), the percentage who experience an accidental pregnancy during the first year if they do not stop use for any other reason.

²Among couples who initiate use of a method (not necessarily for the first time) and who use it perfectly (both consistently and correctly), the percentage who experience an accidental pregnancy during the first year if they do not stop use for any other reason.

³Among couples attempting to avoid pregnancy, the percentage who continue to use a method for 1 year.

⁴The percentages becoming pregnant in columns (2) and (3) are based on data from populations where contraception is not used and from women who cease using contraception in order to become pregnant. Among such populations, about 89% become pregnant within 1 year. This estimate was lowered slightly (to 85%) to represent the percentages who would become pregnant within 1 year among women now relying on reversible methods of contraception if they abandoned contraception altogether.

⁵Foams, creams, gels, vaginal suppositories, and vaginal film.

⁶Cervical mucus (ovulation) method supplemented by calendar in the pre-ovulatory and basal body temperature in the post-ovulatory phases.

⁷With spermicidal cream or jelly.

⁸Without spermicides.

⁹The treatment schedule is one dose within 72 hours after unprotected intercourse, and a second dose 12 hours after the first dose. The Food and Drug Administration has declared the following brands of oral contraceptives to be safe and effective for emergency contraception: Ovral (1 dose is 2 white pills), Alesse (1 dose is 5 pink pills), Nordette or Levlen (1 dose is 4 light-orange pills), Lo/Ovral (1 dose is 4 white pills), Triphasil or Tri-Levlen (1 dose is 4 yellow pills).

¹⁰However, to maintain effective protection against pregnancy, another method of contraception must be used as soon as menstruation resumes, the frequency or duration of breastfeeds is reduced, bottle feeds are introduced, or the baby reaches 6 months of age.

Endometriosis Studies

The efficacy of depo-subQ provera 104 in the reduction of endometriosis-associated pain in women with the signs and symptoms of endometriosis was demonstrated in two active comparator-controlled studies. Each study assessed reduction in endometriosis-associated pain over 6 months of treatment and recurrence of symptoms for 12-months post treatment. Subjects treated with depo-subQ provera 104 for 6 months received a 104 mg dose every 3 months (2 injections), while women treated with leuprolide microspheres for 6 months received a dose of 11.25 mg every 3 months (2 injections) or 3.75 mg every month (6 injections). Study 268 was conducted in the U.S. and Canada and enrolled 274 subjects (136 on depo-subQ provera 104 and 138 on leuprolide). Study 270 was conducted in South America, Europe and Asia, and enrolled 299 subjects (153 on depo-subQ provera 104 and 146 on leuprolide).

Reduction in pain was evaluated using a modified Biberoglu and Behrman scale that consisted of three patient-reported symptoms (dysmenorrhea, dyspareunia, and pelvic pain not related to menses) and two signs assessed during pelvic examination (pelvic tenderness and induration). For each category, a favorable response was defined as improvement of at least 1 unit (severity was assessed on a scale of 0 to 3) relative to baseline score (Figure 2).

Figure 2. Percentages of Responders at End of Treatment (Month 6 or Last Assessment if Earlier) in Studies 268 & 270

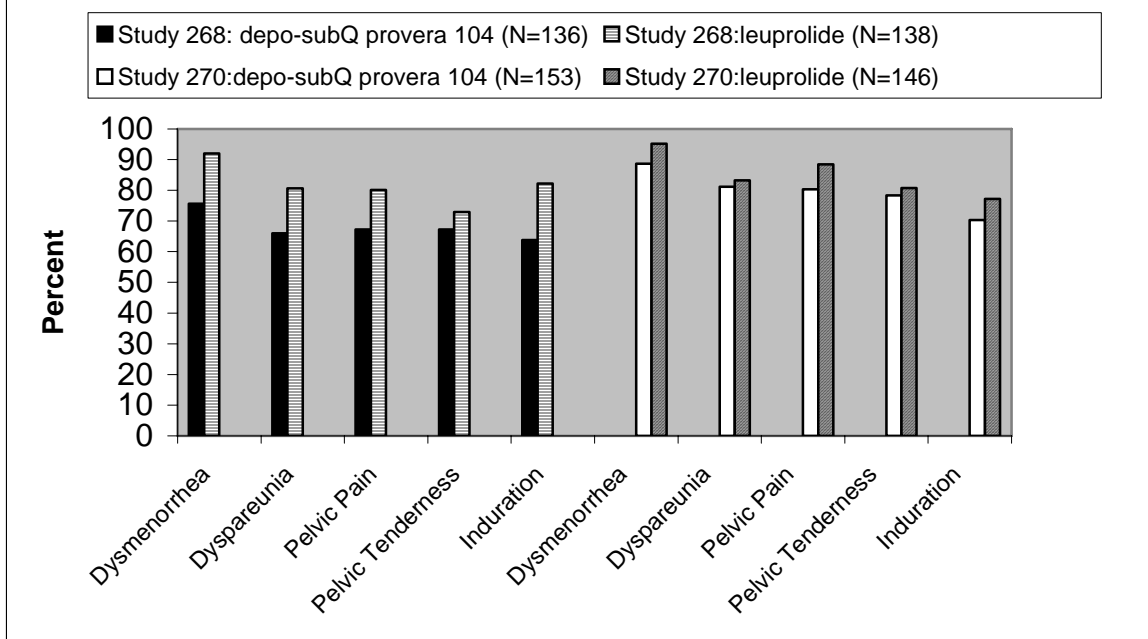

Favorable Response = reduction in severity of symptom or sign of ≥ 1 point on a scale of 0 to 3, as compared to baseline

Additionally, scores from each of the five categories were combined, with the total (composite score) considered a global measurement of overall disease improvement. For subjects with baseline scores for each of the 5 categories, a mean decrease of 4 points relative to baseline was considered a clinically meaningful improvement. Across both studies, for both treatment groups, the mean changes in the composite score met the protocol-defined criterion for improvement.

In the clinical trials, treatment with depo-subQ provera 104 was limited to six months. Data on the persistence of benefit with longer treatment are not available.

Subjects recorded daily the occurrence and severity of hot flashes. Of the depo-subQ provera 104 users, 28.6% reported experiencing moderate or severe hot flashes at baseline, 36.2% at month 3, and 26.7% at month 6. Of the leuprolide users, 32.8% reported experiencing moderate or severe hot flashes at baseline, 74.2% at month 3, and 68.5% at month 6.

CONTRAINDICATIONS

1. Known or suspected pregnancy.
2. Undiagnosed vaginal bleeding.
3. Known or suspected malignancy of breast.
4. Active thrombophlebitis, or current or past history of thromboembolic disorders, or cerebral vascular disease.

5. Significant liver disease.
6. Known hypersensitivity to medroxyprogesterone acetate or any of its other ingredients.

WARNINGS

1. Loss of Bone Mineral Density

Use of depo-subQ provera 104 reduces serum estrogen levels and is associated with significant loss of bone mineral density (BMD) as bone metabolism accommodates to a lower estrogen level. This loss of BMD is of particular concern during adolescence and early adulthood, a critical period of bone accretion. It is unknown if use of depo-subQ provera 104 by younger women will reduce peak bone mass and increase the risk for osteoporotic fracture in later life. In both adults and adolescents, the decrease in BMD appears to be at least partially reversible after depo-subQ provera 104 is discontinued and ovarian estrogen production increases. A study to assess the reversibility of loss of BMD in adolescents is ongoing.

depo-subQ provera 104 should be used long-term (e.g., longer than 2 years) only if other methods of birth control are inadequate. BMD should be evaluated when a woman needs to use depo-subQ provera 104 long-term. In adolescents, interpretation of BMD results should take into account patient age and skeletal maturity.

Other treatments should be considered in the risk/benefit analysis for the use of depo-subQ provera 104 in women with osteoporosis risk factors. depo-subQ provera 104 can pose an additional risk in patients with risk factors for osteoporosis (e.g., metabolic bone disease, chronic alcohol and/or tobacco use, anorexia nervosa, strong family history of osteoporosis or chronic use of drugs that can reduce bone mass such as anticonvulsants or corticosteroids).

Although there are no studies addressing whether calcium and Vitamin D lessen BMD loss in women using depo-subQ provera 104, all patients should have adequate calcium and Vitamin D intake.

BMD Changes in Adult Women after Long-Term Treatment for Contraception

A study comparing changes in BMD in women using depo-subQ provera 104 with women using Depo-Provera Contraceptive Injection (Depo-Provera CI, 150 mg) showed no significant differences in BMD loss between the two groups after two years of treatment. Mean percent changes in BMD in the depo-subQ provera 104 group are listed in Table 3.

Table 3. Mean Percent Change from Baseline in BMD in Women Using depo-subQ provera 104

Time on Treatment	Lumbar Spine		Total Hip		Femoral Neck	
	N	Mean % Change (95% CI)	N	Mean % Change (95% CI)	N	Mean % Change (95% CI)
1 year	166	-2.7 (-3.1 to -2.3)	166	-1.7 (-2.1 to -1.3)	166	-1.9 (-2.5 to -1.4)
2 year	106	-4.1 (-4.6 to -3.5)	106	-3.5 (-4.2 to -2.7)	106	-3.5 (-4.3 to -2.6)

In another controlled clinical study, adult women using Depo-Provera CI (150 mg) for up to 5 years showed spine and hip BMD mean decreases of 5–6%, compared to no significant change in BMD in the control group. The decline in BMD was more pronounced during the first two years of use, with smaller declines in subsequent years. Mean changes in lumbar spine BMD of -2.86%, -4.11%, -4.89%, -4.93% and -5.38% after 1, 2, 3, 4 and 5 years, respectively, were observed. Mean decreases in BMD of the total hip and femoral neck were similar.

After stopping use of Depo-Provera CI (150 mg) there was partial recovery of BMD toward baseline values during the 2-year post-therapy period. Longer duration of treatment was associated with less complete recovery during this 2-year period following the last injection. Table 4 shows the extent of recovery of BMD for women who completed 5 years of treatment.

Table 4. Mean Percent Change from Baseline in BMD in Women Using Depo-Provera CI (150 mg) or in Control Subjects

Time in Study	Lumbar Spine		Total Hip		Femoral Neck	
	Depo-Provera CI (150 mg)*	Control**	Depo-Provera CI (150 mg)*	Control**	Depo-Provera CI (150 mg)*	Control**
5 years	n=33 -5.38%	n=105 0.43%	n=21 -5.16%	n=65 0.19%	n=34 -6.12%	n=106 -0.27%
7 years	n=12 -3.13%	n=60 0.53%	n=7 -1.34%	n=39 0.94%	n=13 -5.38	n=63 -0.11%

*The treatment group consisted of women who received Depo-Provera CI (150 mg) for 5 years and were then followed for 2 years post-use.

**The control group consisted of women who did not use hormonal contraception and were followed for 7 years.

BMD Changes in Adolescent Females (12–18 years) after Long-Term Treatment for Contraception

Preliminary results from an ongoing, open-label, self-selected, non-randomized clinical study of adolescent females (12–18 years) also showed that Depo-Provera CI (150 mg) use was associated with a significant decline in BMD from baseline (Table 5). In general, adolescents increase bone density during the period of growth following menarche, as seen in the untreated cohort. However, the two cohorts were not matched at baseline for age, gynecologic age, race, BMD and other factors that influence the rate of acquisition of bone mineral density, with the result that they differed with respect to these demographic factors.

Preliminary data from the small number of adolescents participating in the 2-year post-use observation period demonstrated partial recovery of BMD.

Table 5. Mean Percent Change from Baseline in BMD in Adolescents Using Depo-Provera CI (150 mg) and in Unmatched, Untreated Control Cohort Studies

Duration of Treatment Or Observation Period	Lumbar Spine				Total Hip				Femoral Neck			
	Depo-Provera CI (150 mg)		Control (Unmatched/ Untreated)		Depo-Provera CI (150 mg)		Control (Unmatched/ Untreated)		Depo-Provera CI (150 mg)		Control (Unmatched/ Untreated)	
	N	Mean % change	N	Mean % change	N	Mean % change	N	Mean % change	N	Mean % change	N	Mean % change
Week 60 (1.2 yrs)	104	-2.42	171	3.47	103	-2.82	171	1.32	103	-3.05	171	1.87
Week 144 (2.8 yrs)	46	-2.78	111	5.41	45	-6.16	111	1.74	45	-6.01	111	2.54
Week 240 (4.6 yrs)	9	-4.17	70	5.12	9	-6.92	69	1.12	9	-6.06	69	1.45

BMD Changes in Adult Women after Six Months of Treatment for Endometriosis

In two clinical studies of 573 adult women with endometriosis, the BMD effects of 6 months of depo-subQ provera 104 treatment were compared to 6 months of leuprolide treatment. Subjects were then observed, off therapy, for an additional 12 months (Table 6).

Table 6. Mean Percent Change from Baseline in BMD after 6 Months on Therapy with depo-subQ provera 104 or Leuprolide and 6 and 12 Months after Stopping Therapy (Studies 268 and 270 Combined)

Time of Measurement	Lumbar Spine				Total Hip			
	depo-subQ provera 104		Leuprolide		depo-subQ provera 104		Leuprolide	
	N	Mean % change	N	Mean % change	N	Mean % change	N	Mean % change
Month 6 of treatment (EOT)	208	-1.20	229	-4.10	207	-0.03	227	-1.83
6 months off treatment	168	-1.06	180	-2.75	169	-0.05	181	-1.59
12 months off treatment	124	-0.54	133	-1.48	125	0.39	134	-1.15

EOT = End of Treatment

2. Bleeding Irregularities

Most women using depo-subQ provera 104 experienced changes in menstrual bleeding patterns, such as amenorrhea, irregular spotting or bleeding, prolonged spotting or bleeding, and heavy bleeding. As women continued using depo-subQ provera 104, fewer experienced irregular bleeding and more experienced amenorrhea. If abnormal bleeding is persistent or severe, appropriate investigation and treatment should be instituted.

In three contraception trials, 39.0 % of women experienced amenorrhea during month six, and 56.5% experienced amenorrhea during month 12. The changes in menstrual bleeding patterns from the three contraception trials are presented in Figures 3 and 4.

Figure 3. Percentages of depo-subQ provera 104 Treated Women with Amenorrhea per 30-Day Month in Contraception Studies (ITT Population, N=2053)

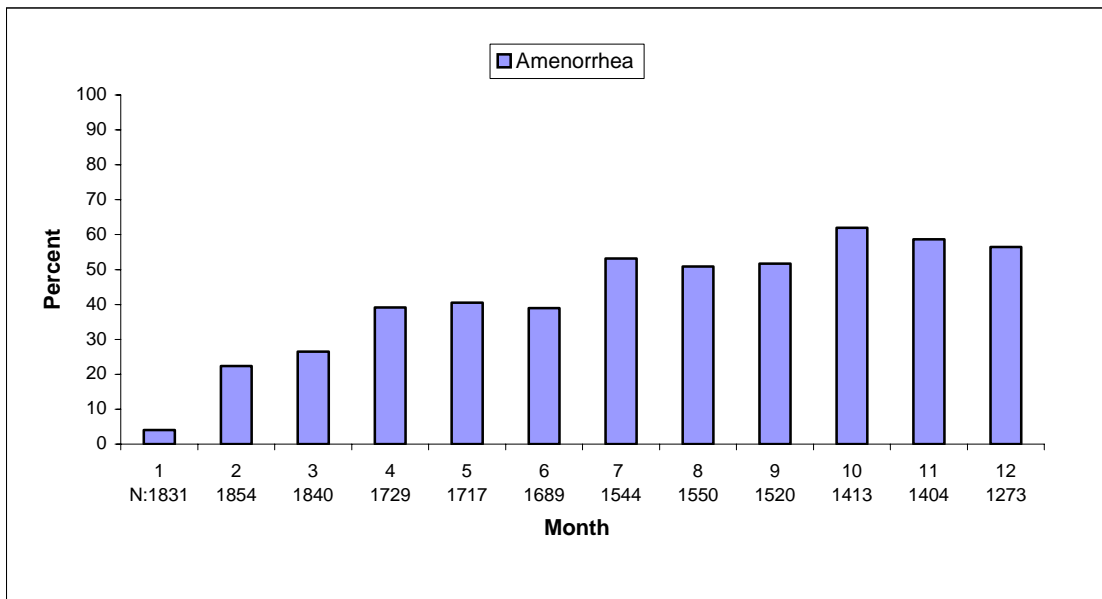

N = Number of subjects in analysis for indicated month

Figure 4. Mean (25th, 75th Percentiles) Number of Bleeding and/or Spotting Days in the Subgroup of Women with Bleeding and/or Spotting by Month for Women Treated with depo-subQ provera 104 in Contraception Studies

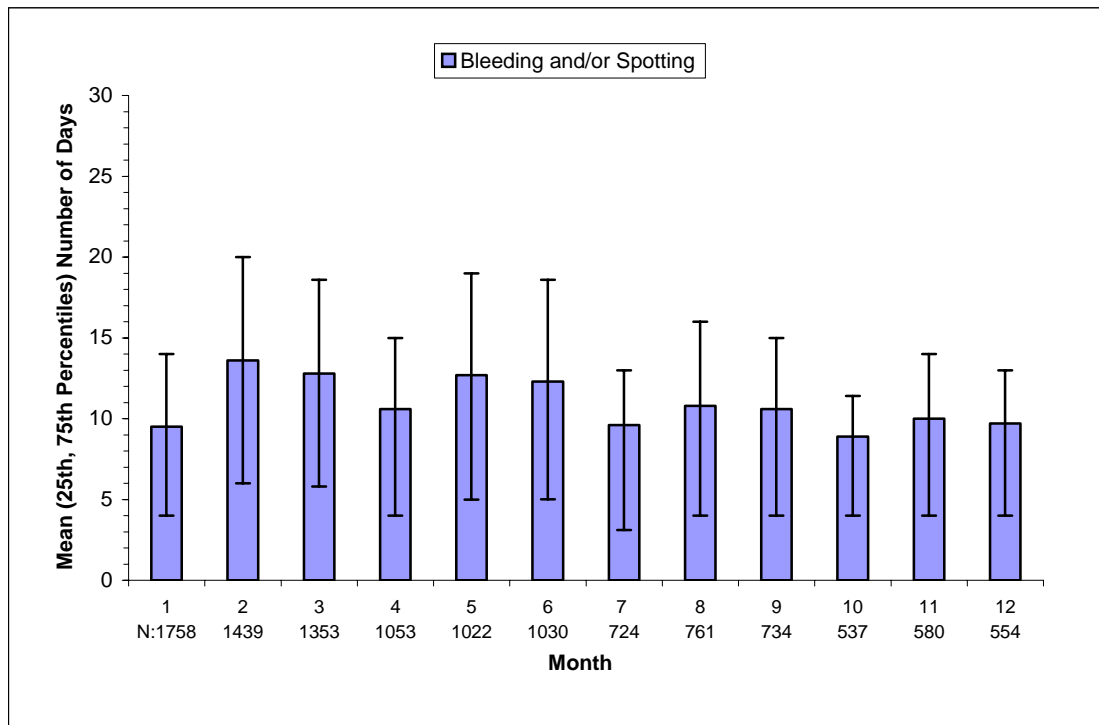

N = Number of subjects with bleeding and/or spotting during indicated month

The changes in menstrual patterns in the two endometriosis trials are presented in Figures 5 and 6.

Figure 5. Percentages of depo-subQ provera 104 Treated Women with Amenorrhea per 30-Day Month in Endometriosis Studies (Combined ITT Population, N=289)

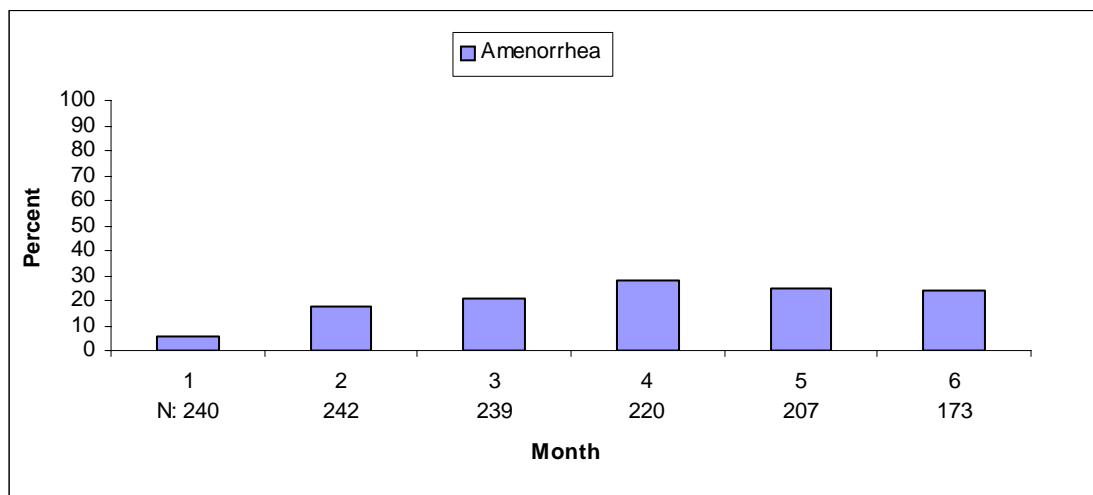

N = Number of subjects in analysis for indicated month

Figure 6. Mean (25th, 75th Percentiles) Number of Bleeding and/or Spotting Days in the Subgroup of Women with Bleeding and/or Spotting by Month for Women Treated with depo-subQ provera 104 in Endometriosis Studies Combined

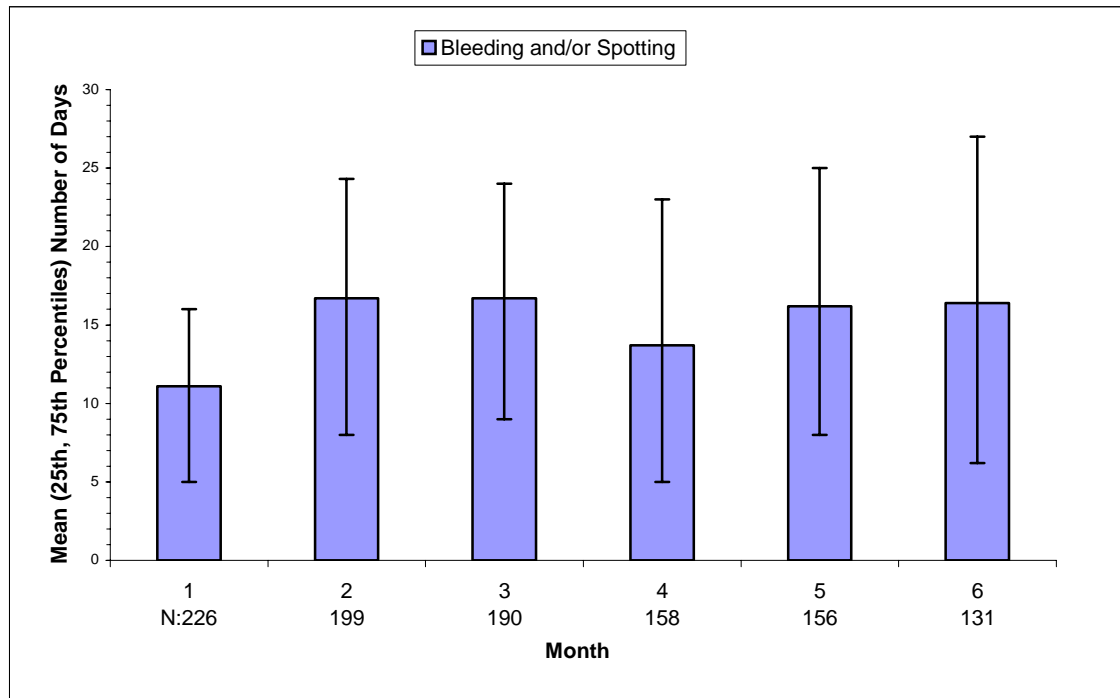

N = Number of subjects with bleeding and/or spotting during indicated month

3. Cancer Risks

Long-term, case-controlled surveillance of users of depot medroxyprogesterone acetate IM 150 mg (Depo-Provera CI, 150 mg) found slight or no increased overall risk of breast cancer and no overall increased risk of ovarian, liver, or cervical cancer, and a prolonged, protective effect of reducing the risk of endometrial cancer.

A pooled analysisⁱⁱ from two case-control studies^{iii iv} reported the relative risk (RR) of breast cancer for women who had ever used Depo-Provera CI (150 mg) as 1.1 (95% confidence interval [CI] 0.97 to 1.4). Overall, there was no increase in risk with increasing duration of use of Depo-Provera CI (150 mg). The RR of breast cancer for women of all ages who had initiated use of Depo-Provera CI (150 mg) within the previous 5 years was estimated to be 2.0 (95% CI 1.5 to 2.8). A component of the pooled analysisⁱⁱⁱ described above, showed an increased RR of 2.19 (95% CI 1.23 to 3.89) of breast cancer associated with use of Depo-Provera CI (150 mg) in women whose first exposure to drug was within the previous 4 years and who were under 35 years of age. However, the overall RR for ever-users of Depo-Provera CI (150 mg) was only 1.21 (95% CI 0.96 to 1.52).

[NOTE: The value of 2.19 means that women whose first exposure to drug was within the previous 4 years and who were under 35 years of age had a 2.19-fold (95% CI 1.23 to 3.89-fold) increased risk of breast cancer relative to nonusers. The National Cancer

Institute^v reports an average annual incidence rate for breast cancer for US women, all races, age 30 to 34 years of 26.7 per 100,000. A RR of 2.19, thus, increases the possible risk from 26.7 to 58.5 cases per 100,000 women. The attributable risk, thus, is 31.8 per 100,000 women per year.]

The relative rate of invasive squamous-cell cervical cancer in women who ever used Depo-Provera CI (150 mg) was estimated to be 1.11 (95% CI 0.96 to 1.29). No trends in risk with duration of use or times since initial or most recent exposure were observed.

4. Thromboembolic Disorders

Although MPA has not been causally associated with the induction of thrombotic or thromboembolic disorders, there have been rare reports of serious thrombotic events in women using Depo-Provera CI (150 mg). Any patient who develops thrombosis while undergoing therapy with depo-subQ provera 104 should discontinue treatment unless she has no other acceptable options for birth control (see CONTRAINDICATIONS).

5. Ocular Disorders

Medication should not be re-administered pending examination if there is a sudden partial or complete loss of vision or if there is a sudden onset of proptosis, diplopia or migraine. If examination reveals papilledema or retinal vascular lesions, medication should not be re-administered.

6. Ectopic Pregnancy

Healthcare providers should be alert to the possibility of an ectopic pregnancy among women using depo-subQ provera 104 who become pregnant or complain of severe abdominal pain.

7. Anaphylaxis and Anaphylactoid Reaction

Serious anaphylactic reactions have been infrequently reported in women using Depo-Provera CI (150 mg). If an anaphylactic reaction occurs, appropriate emergency medical treatment should be instituted.

PRECAUTIONS

1. Physical Examination

It is good medical practice for all women to have annual history and physical examinations, including women using depo-subQ provera 104. The physical examination, however, may be deferred until after initiation of depo-subQ provera 104 if requested by the woman and judged appropriate by the clinician. The physical examination should include special reference to blood pressure, breasts, abdomen and pelvic organs, including cervical cytology and relevant laboratory tests. In case of undiagnosed, persistent or recurrent abnormal vaginal bleeding, appropriate measures should be conducted to rule out malignancy. Women with a strong family history of breast cancer or who have breast nodules should be monitored with particular care.

2. Fluid Retention

Because progestational drugs may cause some degree of fluid retention, conditions that might be influenced by this condition, such as epilepsy, migraine, asthma, and cardiac or renal dysfunction, require careful observation.

3. Weight Gain

Weight gain is a common occurrence in women using depo-subQ provera 104. In three large clinical trials using depo-subQ provera 104, the mean weight gain was 3.5 lb in the first year of use. In a small, two-year study comparing depo-subQ provera 104 to Depo-Provera CI (150 mg), the mean weight gain observed for women using depo-subQ provera 104 (7.5 lb) was similar to the mean weight gain for women using Depo-Provera CI, 150 mg (7.6 lb).

Although there are no data related to weight gain beyond 2 years for depo-subQ provera 104, the data on Depo-Provera CI (150 mg) may be relevant. In a clinical study, after five years, 41 women using Depo-Provera CI (150 mg) had a mean weight gain of 11.2 lb, while 114 women using non-hormonal contraception had a mean weight gain of 6.4 lb.

4. Return to Ovulation and Fertility

Return to ovulation is likely to be delayed after stopping therapy. Among 15 women who received multiple doses of depo-subQ provera 104:

- Median time to ovulation was 10 months after the last injection
- Earliest return to ovulation was 6 months after the last injection
- 12 women (80%) ovulated within 1 year of the last injection

However, ovulation has occurred as early as 14 weeks after a single dose of depo-subQ provera 104, and therefore it is important to follow the recommended dosing schedule.

Return to fertility also is likely to be delayed after stopping therapy. Among 28 women using depo-subQ provera 104 for contraception who stopped treatment to become pregnant, 1 became pregnant within 1 year of her last injection. A second woman became pregnant 443 days after her last injection. Seven women were lost to follow-up.

5. Depression

Patients with a history of treatment for clinical depression should be carefully monitored while receiving depo-subQ provera 104.

6. Injection Site Reactions

In 5 clinical studies of depo-subQ provera 104 involving 2,325 women (282 treated for up to 6 months, 1,780 treated for up to 1 year and 263 women treated for up to 2 years), 5% of women reported injection site reactions, and 1% had persistent skin changes, typically described as small areas of induration or atrophy.

7. Carbohydrate/Metabolism

Some patients receiving progestins may exhibit a decrease in glucose tolerance. Diabetic patients should be carefully observed while receiving such therapy.

8. Liver Function

If jaundice or any other liver abnormality develops in any woman receiving depo-subQ provera 104, treatment should be stopped while the cause is determined. Treatment may be resumed when liver function is acceptable and when the healthcare provider has determined that depo-subQ provera 104 did not cause the abnormality.

9. Drug Interactions

No drug-drug interaction studies have been conducted with depo-subQ provera 104. Aminoglutethimide administered concomitantly with depo-subQ provera 104 may significantly decrease the serum concentrations of MPA.

10. Laboratory Tests

The pathologist should be advised of progestin therapy when relevant specimens are submitted. The physician should be informed that certain endocrine and liver function tests, and blood components may be affected by progestin therapy:

- (a) Plasma and urinary steroid levels are decreased (e.g., progesterone, estradiol, pregnanediol, testosterone, cortisol).
- (b) Plasma and urinary gonadotropin levels are decreased (e.g., LH, FSH).
- (c) SHBG concentrations are decreased.
- (d) T₃-uptake values may decrease.
- (e) There may be small changes in coagulation factors.
- (f) Sulfobromophthalein and other liver function test values may be increased slightly.
- (g) There may be small changes in lipid profiles.

11. Carcinogenesis, Mutagenesis, Impairment of Fertility

See WARNINGS, section 3 and PRECAUTIONS, section 4

12. Pregnancy

Although depo-subQ provera 104 should not be used during pregnancy, there appears to be little or no increased risk of birth defects in women who have inadvertently been exposed to medroxyprogesterone acetate injections in early pregnancy. Neonates exposed to medroxyprogesterone acetate in-utero and followed to adolescence showed no evidence of any adverse effects on their health including their physical, intellectual, sexual or social development.

13. Nursing Mothers

Although the drug is detectable in the milk of mothers receiving Depo-Provera CI (150 mg), milk composition, quality, and amount are not adversely affected. Neonates and infants exposed to medroxyprogesterone acetate from breast milk have been studied for developmental and behavioral effects through puberty, and no adverse effects have been noted.

14. Pediatric Use

depo-subQ provera 104 is not indicated before menarche. Use of depo-subQ provera 104 is associated with significant loss of bone mineral density (BMD). This loss of BMD is of particular concern during adolescence and early adulthood, a critical period of bone accretion. **In adolescents, interpretation of BMD results should take into account patient age and skeletal maturity.** It is unknown if use of depo-subQ provera 104 by younger women will reduce peak bone mass and increase the risk for osteoporotic fractures in later life. Other than concerns about loss of BMD, the safety and effectiveness are expected to be the same for postmenarchal adolescents and adult women.

15. Geriatric Use

depo-subQ provera 104 is intended for use in women with childbearing potential. Studies with depo-subQ provera 104 in geriatric women have not been conducted.

INFORMATION FOR THE PATIENT

See PATIENT LABELING.

ADVERSE REACTIONS

In five clinical studies of depo-subQ provera 104 involving 2,325 women (282 treated for up to 6 months, 1,780 treated for up to 1 year and 263 treated for up to 2 years), 9% of women discontinued treatment for adverse reactions. Among these 212 women, the most common reasons for discontinuation were:

- Uterine bleeding irregularities (35%, n=75)
- Increased weight (18%, n=39)
- Decreased libido (11%, n=23)
- Acne (10%, n=21)
- Injection site reactions (6%, n=12)

Adverse reactions reported by 5% or more of all women in these clinical trials included:

- Headache (9%)
- Intermenstrual bleeding (7%)
- Increased weight (6%)
- Amenorrhea (6%)
- Injection site reactions (5%)

Adverse reactions reported by 1% to <5% of all women in these clinical trials included:

General disorders: fatigue, injection site pain

Gastrointestinal disorders: abdominal distention, abdominal pain, diarrhea, nausea

Infections: bronchitis, influenza, nasopharyngitis, pharyngitis, sinusitis, upper respiratory tract infection, urinary tract infection, vaginal candidiasis, vaginitis, vaginitis bacterial

Investigations: abnormal cervix smear

Musculoskeletal, connective tissue, and bone disorders: arthralgia, back pain, limb pain

Nervous system disorders: dizziness, insomnia

Psychiatric disorders: anxiety, depression, irritability, decreased libido

Reproductive system and breast disorders: breast pain, breast tenderness, menometrorrhagia, menorrhagia, menstruation irregular, uterine hemorrhage, vaginal hemorrhage

Skin disorders: acne

Vascular disorders: hot flushes

Postmarketing Experience

There have been rare cases of osteoporosis including osteoporotic fractures reported postmarketing in patients taking DEPO-PROVERA Contraceptive Injection. In addition, infrequent voluntary reports of anaphylaxis and anaphylactoid reaction have been received associated with use of Depo-Provera CI (150 mg).

The following additional reactions have been reported with Depo-Provera Contraceptive Injection and may occur with use of depo-subQ provera 104:

General disorders: asthenia, axillary swelling, chills, chest pain, fever, excessive thirst

Blood and lymphatic system disorders: anemia, blood dyscrasia

Cardiac disorders: tachycardia

Gastrointestinal disorders: gastrointestinal disturbances, rectal bleeding

Hepato-biliary disorders: jaundice

Immune system disorders: allergic reaction

Infections: genitourinary infections

Investigations: decreased glucose tolerance

Musculoskeletal, connective tissue, and bone disorders: loss of bone mineral density, scleroderma

Neoplasms: breast cancer, cervical cancer

Nervous system disorders: convulsions, facial palsy, fainting, paralysis, paresthesia, somnolence

Psychiatric disorders: increased libido, nervousness

Reproductive system and breast disorders: breast lumps, galactorrhea, nipple discharge or bleeding, oligomenorrhea, prevention of lactation, prolonged anovulation, unexpected pregnancy, uterine hyperplasia, vaginal cyst

Respiratory disorders: asthma, dyspnea, hoarseness

Skin disorders: angioedema, dry skin, increased body odor, melasma, pruritus, urticaria

Vascular disorders: deep vein thrombosis, pulmonary embolus, thrombophlebitis

DOSAGE AND ADMINISTRATION

CONTRACEPTION AND ENDOMETRIOSIS INDICATIONS

Route of Administration

depo-subQ provera 104 must be given by subcutaneous injection into the anterior thigh or abdomen, once every 3 months (12 to 14 weeks). depo-subQ provera 104 is not formulated for intramuscular injection. Dosage does not need to be adjusted for body weight. The pre-filled syringe of depo-subQ provera 104 must be vigorously shaken just before use to create a uniform suspension.

First Injection

Ensure that the patient is not pregnant at the time of the first injection. For women who are sexually active and having regular menses, the first injection should be given only during the first 5 days of a normal menstrual period. Women who are breast-feeding may have their first injection during or after their sixth postpartum week.

Second and Subsequent Injections

Dosing is every 12 to 14 weeks. If more than 14 weeks elapse between injections, pregnancy should be ruled out before the next injection.

IF USING FOR CONTRACEPTION AND SWITCHING FROM ANOTHER METHOD

When switching from other contraceptive methods, depo-subQ provera 104 should be given in a manner that ensures continuous contraceptive coverage. For example, patients switching from combined (estrogen plus progestin) contraceptives should have their first injection of depo-subQ provera 104 within 7 days after the last day of using that method (7 days after taking the last active pill, removing the patch or ring). Similarly, contraceptive coverage will be maintained in switching from Depo-Provera CI (150 mg) to depo-subQ provera 104, provided the next injection is given within the prescribed dosing period for Depo-Provera CI (150 mg).

IF USING FOR TREATMENT OF ENDOMETRIOSIS

Treatment for longer than two years is not recommended, due to the impact of long-term depo-subQ provera 104 on bone mineral density. If symptoms return after discontinuation of treatment, bone mineral density should be evaluated prior to retreatment.

Instructions for Administration of depo-subQ provera 104 for Subcutaneous Use

Please read these instructions carefully. It is very important that the entire dose of depo-subQ provera 104 is given

Getting ready

Ensure that the medication is at room temperature. Make sure the following components are available.

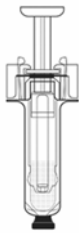

Prefilled syringe
with needle guard

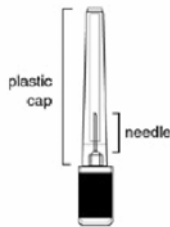

Needle in
sterile package



Alcohol pad

depo-subQ provera 104, as with other parenteral drug products, should be inspected visually for particulate matter and discoloration prior to administration.

Step 1: Choosing & preparing the injection Area

Choose the injection area.

- Avoid boney areas and the umbilicus
- The upper thigh & abdomen are preferred injection sites. See shaded areas to right

Use an alcohol pad to wipe the skin in the injection area you have chosen.

- Allow the skin to dry

Preferred injection areas:

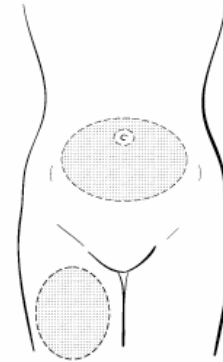

Step 2: Syringe preparation

Gently twist off the protective end cap from the needle to break the seal.

- Set cap aside



Hold the syringe firmly by the barrel pointing upward.

- **Shake it forcefully for at least 1 minute** to thoroughly mix the medication

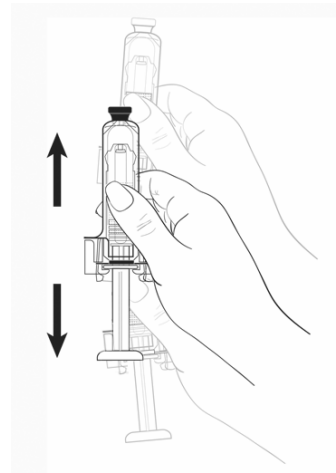

Hold the syringe barrel firmly.

- **Remove the protective tip cap from the syringe and attach the needle** by pushing it onto the barrel tip.

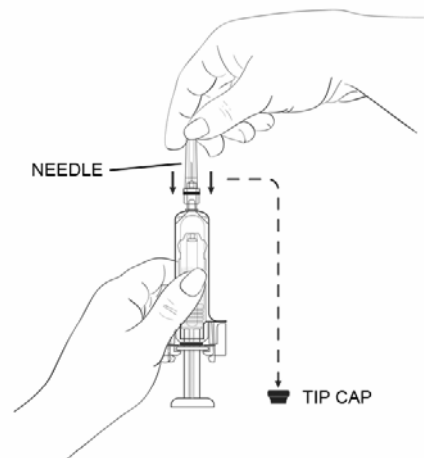

Continue to hold the syringe barrel firmly.

- **Remove the clear protective plastic cover from the needle**, making sure the needle is still firmly attached to the syringe

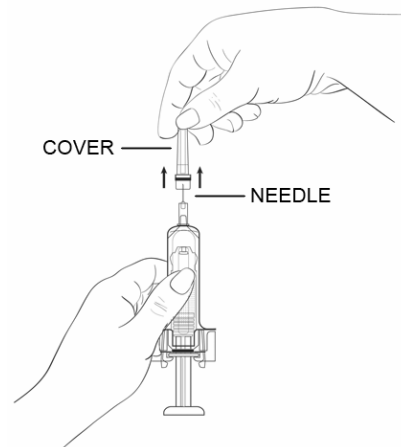

While holding the syringe with the needle pointing upward,

- **Gently push in the plunger** until the medicine is up to the top of the syringe—there should be no air within the barrel

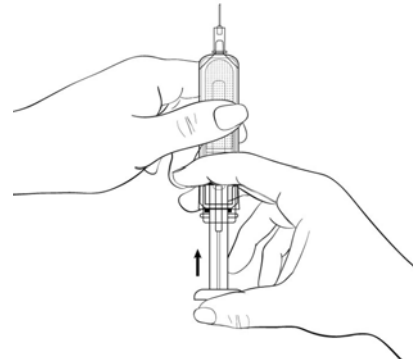

Step 3: Injecting the dose

Gently grasp and squeeze a large area of skin in the chosen injection area between the thumb and forefinger, pulling it away from the body.

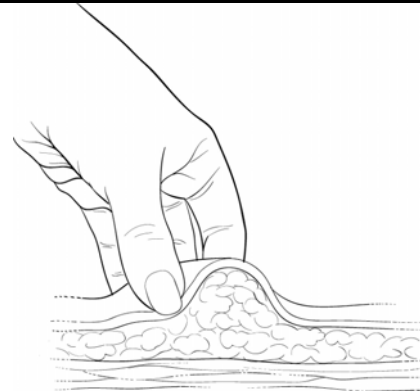

Insert the needle at a 45 degree angle so that most of the needle is in the fatty tissue.

- The plastic hub of the needle should be nearly or almost touching the skin

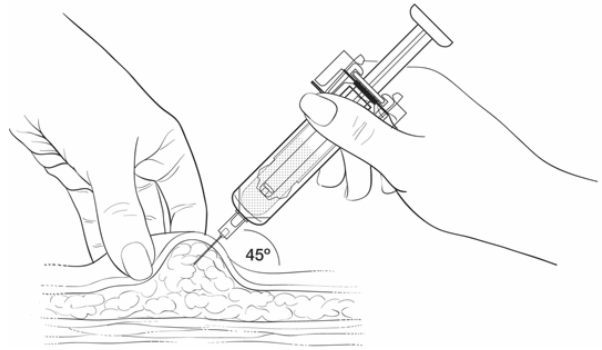

Inject the medication slowly until the syringe is empty.

- It is important that the entire dose of depo-subQ provera 104 is given
- This should take about 5–7 seconds

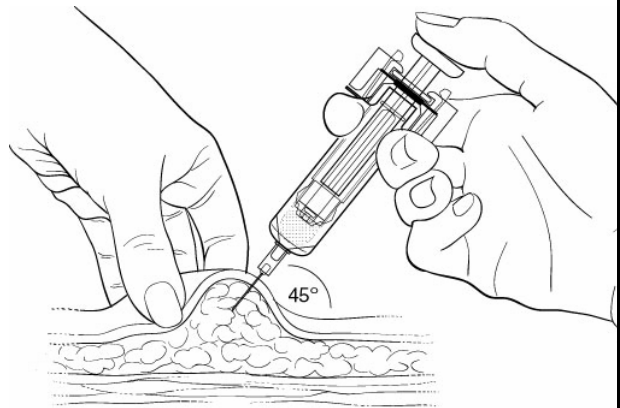

After the entire dose is delivered, **the plunger reaches the activation arms** (see diagram to right)

Some resistance might be felt when the activation arms are pushed open by the plunger rod

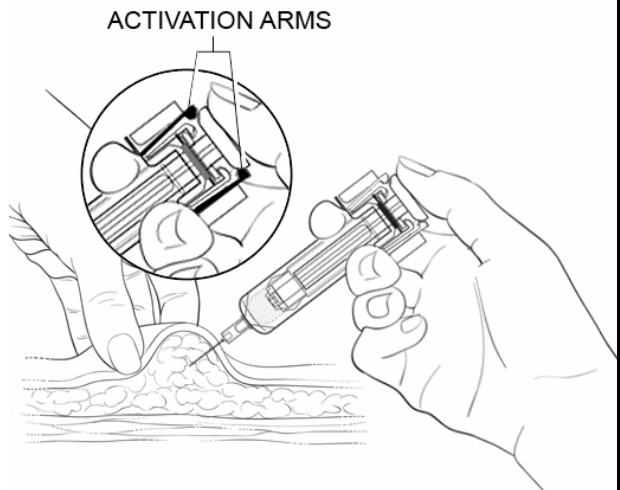

Remove your thumb from the plunger while the syringe is still in the tissue.

- **The syringe will automatically retract** from the tissue and into the device, activating the needle guard
- You may feel the spring's force when the needle retracts

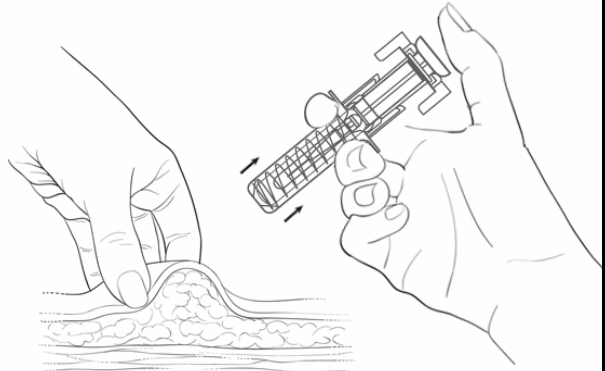

Use a clean cotton pad to **press lightly on the injection area** for a few seconds.

- **Do NOT rub the area**

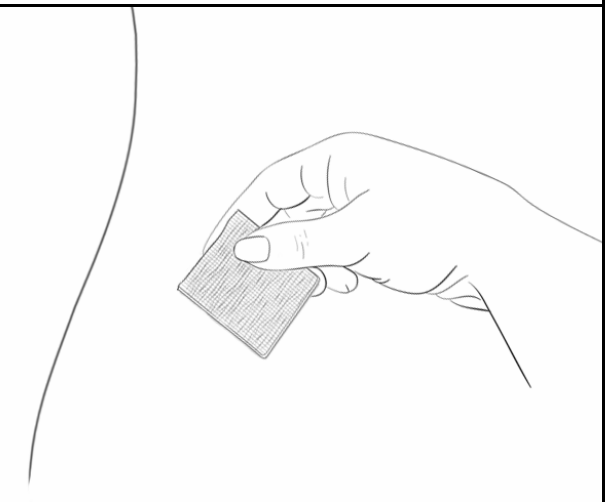

Following the administration of each dose, **the used syringe should be discarded in a safe and proper manner.**

Keep away from children.

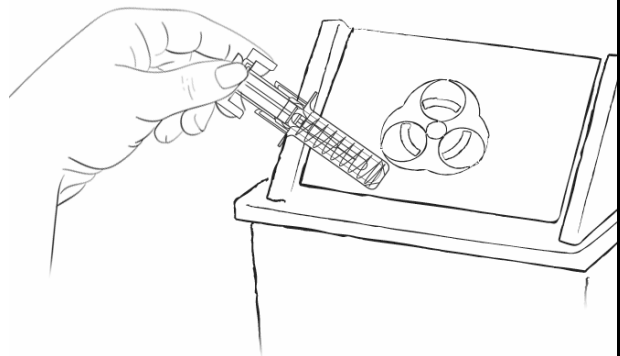

HOW SUPPLIED

depo-subQ provera 104 for subcutaneous use (medroxyprogesterone acetate injectable suspension 104 mg/0.65 mL) is available as a pre-filled syringe, pre-assembled with an UltraSafe Passive™ Needle Guard* device, and packaged with a 26-gauge x 3/8 inch needle in the following presentation:

NDC 0009-4709-01 0.65 mL single-use, disposable syringe

Store at controlled room temperature 20° to 25° C (68° to 77°F) [see USP].

*UltraSafe Passive™ Needle Guard is a trademark of Safety Syringes, Inc.

Rx only



Distributed by

Pharmacia & Upjohn Company
Division of Pfizer Inc, NY, NY 10017

LAB-0295-5.0

Revised October 2007

-
- i Trussell J. Contraceptive efficacy. In Hatcher RA, Trussell J, Stewart F, Cates W, Stewart GK, Kowel D, Guest F, Contraceptive Technology: 17th Revised Edition. New York, NY: Irvington Publishers, 1998.
 - ii Skegg DCG, Noonan EA, Paul C, Spears GFS, Meirik O, Thomas DB. Depot Medroxyprogesterone Acetate and Breast Cancer: A Pooled Analysis from the World Health Organization and New Zealand Studies. JAMA. 1995; 273(10): 799–804.
 - iii WHO Collaborative Study of Neoplasia and Steroid Contraceptives. Breast cancer and depot-medroxyprogesterone acetate: a multi-national study. Lancet. 1991; 338:833–838.
 - iv Paul C, Skegg DCG, Spears GFS. Depot medroxyprogesterone (Depo-Provera) and risk of breast cancer. Br Med J. 1989; 299:759–762.
 - v Surveillance, Epidemiology, and End Results: Incidence and Mortality Data, 1973–1977. National Cancer Institute Monograph, 57: June 1981. (NIH publication No. 81-2330).