

## HIGHLIGHTS OF PRESCRIBING INFORMATION

These highlights do not include all the information needed to use NEXIUM I.V. safely and effectively. See full prescribing information for NEXIUM I.V.

NEXIUM® I.V. (esomeprazole sodium) for injection, for intravenous use  
Initial U.S. Approval: 2005

### RECENT MAJOR CHANGES

Contraindications (4) 09/2019

### INDICATIONS AND USAGE

NEXIUM I.V. is a proton pump inhibitor (PPI) indicated for the:

- Short-term treatment of Gastroesophageal Reflux Disease (GERD) with erosive esophagitis (EE) in adults and pediatric patients 1 month to 17 years of age, as an alternative to oral therapy when oral NEXIUM is not possible or appropriate. (1.1)
- Risk reduction of rebleeding of gastric or duodenal ulcers following therapeutic endoscopy for acute bleeding gastric or duodenal ulcers in adults. (1.2)

### DOSAGE AND ADMINISTRATION

GERD with Erosive Esophagitis. (2.1):

- The recommended adult dosage is either 20 mg or 40 mg once daily by intravenous injection (no less than 3 minutes) or intravenous infusion (10 minutes to 30 minutes) for up to 10 days.
- The recommended pediatric dosage is based upon age and weight. See full prescribing information.

Risk Reduction of Rebleeding of Gastric and Duodenal Ulcers (2.2):

- The recommended adult dosage is 80 mg administered as an intravenous infusion over 30 minutes, followed by a continuous infusion of 8 mg/hour for a total treatment duration of 72 hours.

Dosage Adjustment for Hepatic Impairment (2.3):

- See full prescribing information for dosage adjustment by severity of impairment and by indication.

Preparation and Administration (2.4, 2.5):

- See full prescribing information for preparation and administration instructions by indication.

### DOSAGE FORMS AND STRENGTHS

For Injection: 40 mg of esomeprazole as a lyophilized powder in a single-dose vial for reconstitution. (3)

### CONTRAINDICATIONS

- Patients with known hypersensitivity to any component of the formulation or to substituted benzimidazoles. (4)
- Patients receiving rilpivirine-containing products. (4,7)

## FULL PRESCRIBING INFORMATION: CONTENTS\*

### 1 INDICATIONS AND USAGE

- 1.1 Treatment of Gastroesophageal Reflux Disease (GERD) with Erosive Esophagitis (EE)
- 1.2 Risk Reduction of Rebleeding of Gastric or Duodenal Ulcers following Therapeutic Endoscopy in Adults

### 2 DOSAGE AND ADMINISTRATION

- 2.1 Dosage for GERD with EE
- 2.2 Dosage for Risk Reduction of Rebleeding of Gastric or Duodenal Ulcers following Therapeutic Endoscopy in Adults
- 2.3 Dosage Adjustment for Hepatic Impairment
- 2.4 Preparation and Administration Instructions for GERD with EE
- 2.5 Preparation and Administration Instructions for Risk Reduction of Rebleeding of Gastric or Duodenal Ulcers in Adults

### 3 DOSAGE FORMS AND STRENGTHS

### 4 CONTRAINDICATIONS

### 5 WARNINGS AND PRECAUTIONS

- 5.1 Presence of Gastric Malignancy
- 5.2 Acute Interstitial Nephritis
- 5.3 *Clostridium difficile*-Associated Diarrhea
- 5.4 Bone Fracture
- 5.5 Cutaneous and Systemic Lupus Erythematosus
- 5.6 Interaction with Clopidogrel
- 5.7 Hypomagnesemia
- 5.8 Interaction with St. John's Wort or Rifampin
- 5.9 Interactions with Diagnostic Investigations for Neuroendocrine Tumors
- 5.10 Interaction with Methotrexate
- 5.11 Fundic Gland Polyps

### WARNINGS AND PRECAUTIONS

- **Gastric Malignancy:** In adults, symptomatic response to therapy with NEXIUM I.V. does not preclude the presence of gastric malignancy. Consider additional follow-up and diagnostic testing. (5.1)
- **Acute Interstitial Nephritis:** Observed in patients taking PPIs. (5.2)
- ***Clostridium difficile*-Associated Diarrhea:** PPI therapy may be associated with increased risk. (5.3)
- **Bone Fracture:** Long-term and multiple daily dose PPI therapy may be associated with an increased risk for osteoporosis-related fractures of the hip, wrist or spine. (5.4)
- **Cutaneous and Systemic Lupus Erythematosus:** Mostly cutaneous; new onset or exacerbation of existing disease; discontinue NEXIUM I.V. and refer to specialist for evaluation. (5.5)
- **Interaction with Clopidogrel:** Avoid concomitant use of NEXIUM I.V. (5.6, 7)
- **Hypomagnesemia:** Reported rarely with prolonged treatment with PPIs. (5.7)
- **Interaction with St. John's Wort or Rifampin:** Avoid concomitant use of NEXIUM I.V. (5.8, 7)
- **Interactions with Diagnostic Investigations for Neuroendocrine Tumors:** Increased chromogranin A (CgA) levels may interfere with diagnostic investigations for neuroendocrine tumors; temporarily stop NEXIUM I.V. at least 14 days before assessing CgA levels. (5.9, 7)
- **Interaction with Methotrexate:** Concomitant use with PPIs may elevate and/or prolong serum concentrations of methotrexate and/or its metabolite, possibly leading to toxicity. With high dose methotrexate administration, consider a temporary withdrawal of NEXIUM I.V. (5.10, 7)
- **Fundic Gland Polyps:** Risk increases with long-term use, especially beyond one year. Use the shortest duration of therapy. (5.11)

### ADVERSE REACTIONS

Most common adverse reactions ( $\geq 1\%$ ) are: headache, flatulence, nausea, abdominal pain, injection site reaction, diarrhea, dry mouth, dizziness/vertigo, constipation and pruritus. (6.1)

To report SUSPECTED ADVERSE REACTIONS, contact AstraZeneca at 1-800-236-9933 or FDA at 1-800-FDA-1088 or [www.fda.gov/medwatch](http://www.fda.gov/medwatch).

### DRUG INTERACTIONS

See full prescribing information for a list of clinically important drug interactions. (7)

See 17 for PATIENT COUNSELING INFORMATION.

Revised: 09/2019

### 6 ADVERSE REACTIONS

- 6.1 Clinical Trials Experience
- 6.2 Postmarketing Experience

### 7 DRUG INTERACTIONS

### 8 USE IN SPECIFIC POPULATIONS

- 8.1 Pregnancy
- 8.2 Lactation
- 8.4 Pediatric Use
- 8.5 Geriatric Use
- 8.6 Hepatic Impairment

### 10 OVERDOSAGE

### 11 DESCRIPTION

### 12 CLINICAL PHARMACOLOGY

- 12.1 Mechanism of Action
- 12.2 Pharmacodynamics
- 12.3 Pharmacokinetics
- 12.4 Microbiology
- 12.5 Pharmacogenomics

### 13 NONCLINICAL TOXICOLOGY

- 13.1 Carcinogenesis, Mutagenesis, Impairment of Fertility
- 13.2 Animal Toxicology and/or Pharmacology

### 14 CLINICAL STUDIES

- 14.1 Acid Suppression in GERD
- 14.2 Bleeding Gastric or Duodenal Ulcers

### 16 HOW SUPPLIED/STORAGE AND HANDLING

### 17 PATIENT COUNSELING INFORMATION

\*Sections or subsections omitted from the full prescribing information are not listed.

## FULL PRESCRIBING INFORMATION

### 1 INDICATIONS AND USAGE

#### 1.1 Treatment of Gastroesophageal Reflux Disease (GERD) with Erosive Esophagitis (EE)

NEXIUM I.V. is indicated for the short-term treatment of GERD with EE in adults and pediatric patients 1 month to 17 years, inclusively as an alternative to oral therapy when oral NEXIUM is not possible or appropriate.

#### 1.2 Risk Reduction of Rebleeding of Gastric or Duodenal Ulcers following Therapeutic Endoscopy in Adults

NEXIUM I.V. is indicated for risk reduction of rebleeding of gastric or duodenal ulcers following therapeutic endoscopy for acute bleeding gastric or duodenal ulcers in adults.

### 2 DOSAGE AND ADMINISTRATION

#### 2.1 Dosage for GERD with EE

##### Adult Patients

The recommended adult dosage is either 20 mg or 40 mg NEXIUM I.V. given once daily by intravenous injection (over at least 3 minutes) or intravenous infusion (10 minutes to 30 minutes) for up to 10 days [see [Dosage and Administration \(2.4\)](#)].

##### Pediatric Patients

The recommended dosage for pediatric patients is based on age and body weight as shown in Table 1 below. Administer as an intravenous infusion over 10 to 30 minutes once daily for up to 10 days [see [Dosage and Administration \(2.4\)](#)].

**Table 1: Recommended Pediatric Dosage Regimen for GERD with EE**

Age and Body Weight		Dosage Regimen
1 month to less than 1 year of age		0.5 mg/kg once daily
1 year to 17 years	less than 55 kg	10 mg once daily
	55 kg or greater	20 mg once daily

##### Completion of Treatment

- The safety and effectiveness of NEXIUM I.V. for more than 10 days have not been demonstrated.
- As soon as oral therapy is possible or appropriate, discontinue intravenous therapy with NEXIUM I.V. and continue with oral NEXIUM therapy.

#### 2.2 Dosage for Risk Reduction of Rebleeding of Gastric or Duodenal Ulcers following Therapeutic Endoscopy in Adults

The recommended adult dosage is 80 mg NEXIUM I.V. administered as an intravenous infusion over 30 minutes followed by a continuous infusion of 8 mg/hour for a total treatment duration of 72 hours (i.e., includes initial 30-minute loading dose plus 71.5 hours of continuous infusion) [see [Dosage and Administration \(2.5\)](#)].

Intravenous therapy is aimed solely at the acute initial management of bleeding gastric or duodenal ulcers and does not constitute full treatment. Administer oral acid-suppressive therapy following intravenous therapy for a full course of treatment.

#### 2.3 Dosage Adjustment for Hepatic Impairment

##### GERD with EE

For patients with severe hepatic impairment (Child-Pugh Class C), the maximum dosage is 20 mg once daily [see [Use in Specific Populations \(8.6\)](#)].

### Risk Reduction of Rebleeding of Gastric or Duodenal Ulcers following Therapeutic Endoscopy in Adults

For patients with mild to moderate hepatic impairment (Child-Pugh Classes A and B, respectively), administered 80 mg as an intravenous infusion over 30 minutes, followed by a continuous infusion of 6 mg/hour for 71.5 hours.

For patients with severe hepatic impairment (Child-Pugh Class C), administered 80 mg as an intravenous infusion over 30 minutes, followed by a continuous infusion of 4 mg/hour for 71.5 hours [see [Use in Specific Populations \(8.6\)](#)].

## **2.4 Preparation and Administration Instructions for GERD with EE**

Do not administer NEXIUM I.V. concomitantly with any other medications through the same intravenous site and/or tubing.

Oral antacids may be used during treatment with NEXIUM I.V.

### Intravenous Injection Over At Least 3 Minutes in Adult Patients

1. Reconstitute NEXIUM I.V. with 5 mL of 0.9% Sodium Chloride Injection, USP.
2. Withdraw the desired dose of the reconstituted NEXIUM I.V. solution for a 20 mg or 40 mg dose.
3. Discard any unused portion of NEXIUM I.V. solution remaining in the vial.
4. Inspect the reconstituted NEXIUM I.V. solution visually for particulate matter and discoloration prior to and during administration.
5. Administer as an intravenous injection over no less than 3 minutes.
6. Flush the intravenous line with either 0.9% Sodium Chloride Injection, USP, Lactated Ringer's Injection, USP or 5% Dextrose Injection, USP both prior to and after administration of NEXIUM I.V.

### Intravenous Infusion Over 10 Minutes to 30 Minutes in Adult and Pediatric Patients

1. Reconstitute the contents of one vial of NEXIUM I.V. with 5 mL of 0.9% Sodium Chloride Injection, USP, Lactated Ringer's Injection, USP or 5% Dextrose Injection, USP.
2. Further dilute the resulting solution with 45 mL of 0.9% Sodium Chloride Injection, USP, Lactated Ringer's Injection, USP or 5% Dextrose Injection, USP to a final concentration of 0.8 mg/mL.
3. Withdraw the desired dose of the reconstituted NEXIUM I.V. solution for an adult or pediatric dose.
4. Discard any unused portion of NEXIUM I.V. solution remaining in the vial.
5. Inspect the reconstituted NEXIUM I.V. solution visually for particulate matter and discoloration prior to and during administration.
6. Administer intravenously over 10 minutes to 30 minutes.
7. Flush the intravenous line with either 0.9% Sodium Chloride Injection, USP, Lactated Ringer's Injection, USP or 5% Dextrose Injection, USP both prior to and after administration of NEXIUM I.V.

### Storage

Store the final (diluted) NEXIUM I.V. solution at room temperature up to 30°C (86°F) and administer within the designated time period as listed in Table 2 below.

**Table 2: Storage Time for Final (diluted) NEXIUM I.V. Solution**

<b>Diluent</b>	<b>Administer within:</b>
0.9% Sodium Chloride Injection, USP	12 hours
Lactated Ringer's Injection, USP	12 hours
5% Dextrose Injection, USP	6 hours

## **2.5 Preparation and Administration Instructions for Risk Reduction of Rebleeding of Gastric or Duodenal Ulcers in Adults**

Do not administer NEXIUM I.V. concomitantly with any other medications through the same intravenous site and/or tubing.

Oral antacids may be used during treatment with NEXIUM I.V.

#### Loading Dose (80 mg)

1. Reconstitute each of two 40 mg vials of NEXIUM I.V. with 5 mL of 0.9% Sodium Chloride Injection, USP.
2. Further dilute the resulting solution in 100 mL 0.9% Sodium Chloride Injection, USP.
3. Inspect the reconstituted NEXIUM I.V. solution visually for particulate matter and discoloration prior to and during administration.
4. Administer intravenously over 30 minutes.
5. Flush the intravenous line with either 0.9% Sodium Chloride Injection, USP, Lactated Ringer's Injection, USP or 5% Dextrose Injection, USP both prior to and after administration of NEXIUM I.V.

#### Continuous Infusion

1. Reconstitute each of two 40 mg vials of NEXIUM I.V. with 5 mL of 0.9% Sodium Chloride Injection, USP.
2. Further dilute the reconstituted NEXIUM I.V. solution in 100 mL 0.9% Sodium Chloride Injection, USP.
3. Inspect the reconstituted NEXIUM I.V. solution visually for particulate matter and discoloration prior to and during administration.
4. Administer intravenously as a continuous infusion at a rate of 8 mg/hour for 71.5 hours.
5. Flush the intravenous line with either 0.9% Sodium Chloride Injection, USP, Lactated Ringer's Injection, USP or 5% Dextrose Injection, USP both prior to and after administration of NEXIUM I.V.

#### Storage

- Store the final (diluted) NEXIUM I.V. solution at room temperature up to 30°C (86°F) and administer within 12 hours.

### **3 DOSAGE FORMS AND STRENGTHS**

For Injection: 40 mg of esomeprazole as a white to off-white lyophilized powder in a single-dose vial for reconstitution.

### **4 CONTRAINDICATIONS**

- NEXIUM I.V. is contraindicated in patients with known hypersensitivity to substituted benzimidazoles or to any component of the formulation. Hypersensitivity reactions may include anaphylaxis, anaphylactic shock, angioedema, bronchospasm, acute interstitial nephritis, and urticaria [*see [Adverse Reactions \(6.2\)](#)*].
- Proton pump inhibitors (PPIs), including NEXIUM I.V., are contraindicated in patients receiving rilpivirine-containing products [*see [Drug Interactions \(7\)](#)*].

### **5 WARNINGS AND PRECAUTIONS**

#### **5.1 Presence of Gastric Malignancy**

In adults, symptomatic response to therapy with NEXIUM I.V. does not preclude the presence of gastric malignancy. Consider additional follow-up and diagnostic testing in adults patients who have suboptimal response or an early symptomatic relapse after completing treatment with a PPI. In older patients also consider an endoscopy.

#### **5.2 Acute Interstitial Nephritis**

Acute interstitial nephritis has been observed in patients taking PPIs including NEXIUM I.V. Acute interstitial nephritis may occur at any point during PPI therapy and is generally attributed to an idiopathic hypersensitivity reaction. Discontinue NEXIUM I.V. if acute interstitial nephritis develops [*see [Contraindications \(4\)](#)*].

### 5.3 *Clostridium difficile*-Associated Diarrhea

Published observational studies suggest that PPI therapy like NEXIUM I.V. may be associated with an increased risk of *Clostridium difficile*-associated diarrhea, especially in hospitalized patients. This diagnosis should be considered for diarrhea that does not improve [see [Adverse Reactions \(6.2\)](#)].

Patients should use the lowest dose and shortest duration of PPI therapy appropriate to the condition being treated.

### 5.4 Bone Fracture

Several published observational studies suggest that proton pump inhibitor (PPI) therapy may be associated with an increased risk for osteoporosis-related fractures of the hip, wrist, or spine. The risk of fracture was increased in patients who received high-dose, defined as multiple daily doses, and long-term PPI therapy (a year or longer). Patients should use the lowest dose and shortest duration of PPI therapy appropriate to the condition being treated. Patients at risk for osteoporosis-related fractures should be managed according to established treatment guidelines [see [Dosage and Administration \(2.1, 2.2\)](#), [Adverse Reactions \(6.2\)](#)].

### 5.5 Cutaneous and Systemic Lupus Erythematosus

Cutaneous lupus erythematosus (CLE) and systemic lupus erythematosus (SLE) have been reported in patients taking PPIs, including esomeprazole. These events have occurred as both new onset and an exacerbation of existing autoimmune disease. The majority of PPI-induced lupus erythematosus cases were CLE.

The most common form of CLE reported in patients treated with PPIs was subacute CLE (SCLE) and occurred within weeks to years after continuous drug therapy in patients ranging from infants to the elderly. Generally, histological findings were observed without organ involvement.

Systemic lupus erythematosus (SLE) is less commonly reported than CLE in patients receiving PPIs. PPI associated SLE is usually milder than non-drug induced SLE. Onset of SLE typically occurred within days to years after initiating treatment primarily in patients ranging from young adults to the elderly. The majority of patients presented with rash; however, arthralgia and cytopenia were also reported.

Avoid administration of PPIs for longer than medically indicated. If signs or symptoms consistent with CLE or SLE are noted in patients receiving NEXIUM I.V., discontinue the drug and refer the patient to the appropriate specialist for evaluation. Most patients improve with discontinuation of the PPI alone in 4 to 12 weeks. Serological testing (e.g., ANA) may be positive and elevated serological test results may take longer to resolve than clinical manifestations.

### 5.6 Interaction with Clopidogrel

Avoid concomitant use of NEXIUM I.V. with clopidogrel. Clopidogrel is a prodrug. Inhibition of platelet aggregation by clopidogrel is entirely due to an active metabolite. The metabolism of clopidogrel to its active metabolite can be impaired by use with concomitant medications, such as esomeprazole, that inhibit CYP2C19 activity. Concomitant use of clopidogrel with 40 mg esomeprazole reduces the pharmacological activity of clopidogrel. When using NEXIUM I.V. consider alternative anti-platelet therapy [see [Drug Interactions \(7\)](#)].

### 5.7 Hypomagnesemia

Hypomagnesemia, symptomatic and asymptomatic, has been reported rarely in patients treated with PPIs for at least three months, in most cases after a year of therapy. Serious adverse events include tetany, arrhythmias, and seizures. In most patients, treatment of hypomagnesemia required magnesium replacement and discontinuation of the PPI.

For patients expected to be on prolonged treatment or who take PPIs with medications such as digoxin or drugs that may cause hypomagnesemia (e.g., diuretics), health care professionals may consider monitoring magnesium levels prior to initiation of PPI treatment and periodically [see [Adverse Reactions \(6.2\)](#)].

### 5.8 Interaction with St. John's Wort or Rifampin

Drugs which induce CYP2C19 or CYP3A4 (such as St. John's Wort or rifampin) can substantially decrease esomeprazole concentrations [see [Drug Interactions \(7\)](#)]. Avoid concomitant use of NEXIUM I.V. with St. John's Wort or rifampin.

### 5.9 Interactions with Diagnostic Investigations for Neuroendocrine Tumors

Serum chromogranin A (CgA) levels increase secondary to drug-induced decreases in gastric acidity. The increased CgA level may cause false positive results in diagnostic investigations for neuroendocrine tumors. Healthcare providers should temporarily stop esomeprazole treatment at least 14 days before assessing CgA levels and consider repeating the test if initial CgA levels are high. If serial tests are performed (e.g., for monitoring), the same commercial laboratory should be used for testing, as reference ranges between tests may vary [see [Drug Interactions \(7\)](#)].

### 5.10 Interaction with Methotrexate

Literature suggests that concomitant use of PPIs with methotrexate (primarily at high dose; see methotrexate prescribing information) may elevate and prolong serum levels of methotrexate and/or its metabolite, possibly leading to methotrexate toxicities. In high-dose methotrexate administration, a temporary withdrawal of the PPI may be considered in some patients [see [Drug Interactions \(7\)](#)].

### 5.11 Fundic Gland Polyps

PPI use is associated with an increased risk of fundic gland polyps that increases with long-term use, especially beyond one year. Most PPI users who developed fundic gland polyps were asymptomatic and fundic gland polyps were identified incidentally on endoscopy. Use the shortest duration of PPI therapy appropriate to the condition being treated.

## 6 ADVERSE REACTIONS

The following serious adverse reactions are described below and elsewhere in labeling:

- Acute Interstitial Nephritis [see [Warnings and Precautions \(5.2\)](#)]
- *Clostridium difficile*-Associated Diarrhea [see [Warnings and Precautions \(5.3\)](#)]
- Bone Fracture [see [Warnings and Precautions \(5.4\)](#)]
- Cutaneous and Systemic Lupus Erythematosus [see [Warnings and Precautions \(5.5\)](#)]
- Hypomagnesemia [see [Warnings and Precautions \(5.7\)](#)]
- Fundic Gland Polyps [see [Warnings and Precautions \(5.11\)](#)]

### 6.1 Clinical Trials Experience

Because clinical trials are conducted under widely varying conditions, adverse reaction rates observed in the clinical trials of a drug cannot be directly compared to rates in the clinical trials of another drug and may not reflect the rates observed in practice.

#### Symptomatic GERD and EE

##### *Adults*

The safety of NEXIUM I.V. is based on results from clinical trials conducted in four different populations including healthy subjects (n=204) and patients with bleeding gastric or duodenal ulcers (n=375).

The data described below reflect exposure to NEXIUM I.V. in 359 patients in actively-controlled trials: symptomatic GERD with or without a history of EE (n=199) and patients with EE (n=160). The population was 18 to 77 years of age; 45% Male, 52% Caucasian, 17% Black, 3% Asian, and 28% other race. Most patients received doses of either 20 or 40 mg either as an infusion or an injection. Adverse reactions occurring in at least 1% of patients are listed below in Table 3:

**Table 3: Adverse Reactions<sup>1</sup> in the NEXIUM I.V. Group in Active Controlled Trials of Symptomatic GERD with or without EE**

Adverse Reactions	% of patients NEXIUM I.V. (n=359)
Headache	11
Flatulence	10
Nausea	6
Abdominal pain	6
Diarrhea	4
Mouth dry	4
Dizziness/vertigo	3
Constipation	3
Injection site reaction	2
Pruritus	1

<sup>1</sup> Incidence of at least 1% in the NEXIUM I.V. group

Intravenous treatment with NEXIUM I.V. 20 and 40 mg-administered as an injection or as an infusion was found to have a safety profile similar to that of oral esomeprazole.

#### *Pediatrics*

A randomized, open-label, multi-national study to evaluate the pharmacokinetics of repeated intravenous doses of once daily NEXIUM I.V. in pediatric patients 1 month to 17 years old, inclusive was performed [see [Clinical Pharmacology \(12.3\)](#)]. The safety results are consistent with the known safety profile of esomeprazole and no unexpected safety signals were identified.

#### Risk Reduction of Rebleeding of Gastric or Duodenal Ulcers in Adults

The data described in Table 4 below reflect exposure to NEXIUM I.V. in 375 patients who presented with endoscopically confirmed gastric or duodenal ulcer bleeding in a placebo-controlled trial. The population was 18 to 98 years old; 68% Male, 87% Caucasian, 1% Black, 7% Asian, and 4% other race. Following endoscopic hemostasis, patients received either placebo or 80 mg NEXIUM I.V. as an intravenous infusion over 30 minutes followed by a continuous infusion of 8 mg/hour for a total treatment duration of 72 hours. After the initial 72-hour period, all patients received an oral PPI for 27 days.

**Table 4: Adverse Reactions<sup>1</sup> Occurring within 72 Hours after Start of Treatment in Patients with Endoscopically Confirmed Bleeding Ulcers**

	% of patients	
	NEXIUM I.V. (n=375)	Placebo (n=389)
Duodenal ulcer hemorrhage	4	4
Injection site reaction <sup>2</sup>	4	1
Pyrexia	4	3
Cough	1	0.3
Dizziness	1	1

<sup>1</sup> Incidence  $\geq$ 1% in the NEXIUM I.V. group and greater than placebo group

<sup>2</sup> Injection site reactions included erythema, swelling, inflammation, pruritus, phlebitis, thrombophlebitis and superficial phlebitis.

With the exception of injection site reactions described above, intravenous treatment with NEXIUM I.V. administered as an injection or as an infusion was found to have a safety profile similar to that of oral esomeprazole.

## 6.2 Postmarketing Experience

The following adverse reactions have been identified during post-approval use of esomeprazole. Because these reactions are reported voluntarily from a population of uncertain size, it is not always possible to reliably estimate their frequency or establish a causal relationship to drug exposure.

*Blood and Lymphatic System Disorders:* agranulocytosis, pancytopenia;

*Eye Disorders:* blurred vision;

*Gastrointestinal Disorders:* pancreatitis; stomatitis; microscopic colitis; fundic gland polyps;

*Hepatobiliary Disorders:* hepatic failure, hepatitis with or without jaundice;

*Immune System Disorders:* anaphylactic reaction/shock; systemic lupus erythematosus;

*Infections and Infestations:* GI candidiasis;

*Metabolism and nutritional disorders:* hypomagnesemia with or without hypocalcemia and/or hypokalemia;

*Musculoskeletal and Connective Tissue Disorders:* muscular weakness, myalgia, bone fracture;

*Nervous System Disorders:* hepatic encephalopathy, taste disturbance;

*Psychiatric Disorders:* aggression, agitation, depression, hallucination;

*Renal and Urinary Disorders:* interstitial nephritis;

*Reproductive System and Breast Disorders:* gynecomastia;

*Respiratory, Thoracic and Mediastinal Disorders:* bronchospasm;

*Skin and Subcutaneous Tissue Disorders:* alopecia, erythema multiforme, hyperhidrosis, photosensitivity, Stevens-Johnson syndrome, toxic epidermal necrolysis (TEN, some fatal), cutaneous lupus erythematosus.

Adverse reactions associated with omeprazole may also be expected to occur with NEXIUM I.V. See the full prescribing information for oral omeprazole for complete safety information.

## 7 DRUG INTERACTIONS

Tables 5 and 6 include drugs with clinically important drug interactions and interaction with diagnostics when administered concomitantly with esomeprazole and instructions for preventing or managing them.

Consult the labeling of concomitantly used drugs to obtain further information about interactions with PPIs.

**Table 5: Clinically Relevant Interactions Affecting Drugs Co-Administered with Esomeprazole and Interaction with Diagnostics**

Antiretrovirals	
<i>Clinical Impact:</i>	<p>The effect of PPIs on antiretroviral drugs is variable. The clinical importance and the mechanisms behind these interactions are not always known.</p> <ul style="list-style-type: none"> <li>• Decreased exposure of some antiretroviral drugs (e.g., rilpivirine atazanavir, and nelfinavir) when used concomitantly with esomeprazole may reduce antiviral effect and promote the development of drug resistance [see <i>Clinical Pharmacology</i> (12.3)].</li> <li>• Increased exposure of other antiretroviral drugs (e.g., saquinavir) when used concomitantly with esomeprazole may increase toxicity [see <i>Clinical Pharmacology</i> (12.3)].</li> <li>• There are other antiretroviral drugs which do not result in clinically relevant interactions with esomeprazole.</li> </ul>
<i>Intervention:</i>	<p><u>Rilpivirine-containing products:</u> Concomitant use with NEXIUM I.V. is contraindicated [see <i>Contraindications</i> (4)].</p> <p><u>Atazanavir:</u> See prescribing information for atazanavir for dosing information.</p>

	<p><u>Nelfinavir</u>: Avoid concomitant use with NEXIUM I.V. See prescribing information for nelfinavir.</p> <p><u>Saquinavir</u>: See the prescribing information for saquinavir for monitoring of potential saquinavir-related toxicities.</p> <p><u>Other antiretrovirals</u>: See prescribing information for specific antiretroviral drugs</p>
<b>Warfarin</b>	
<i>Clinical Impact:</i>	Increased INR and prothrombin time in patients receiving PPIs, including esomeprazole, and warfarin concomitantly. Increases in INR and prothrombin time may lead to abnormal bleeding and even death.
<i>Intervention:</i>	Monitor INR and prothrombin time and adjust the dose of warfarin, if needed, to maintain the target INR range.
<b>Methotrexate</b>	
<i>Clinical Impact:</i>	Concomitant use of esomeprazole with methotrexate (primarily at high dose) may elevate and prolong serum concentrations of methotrexate and/or its metabolite hydroxymethotrexate, possibly leading to methotrexate toxicities. No formal drug interaction studies of high-dose methotrexate with PPIs have been conducted [see <i>Warnings and Precautions (5.10)</i> ].
<i>Intervention:</i>	A temporary withdrawal of NEXIUM I.V. may be considered in some patients receiving high-dose methotrexate.
<b>2C19 Substrates (e.g., clopidogrel, citalopram, cilostazol, diazepam)</b>	
<b>Clopidogrel</b>	
<i>Clinical Impact:</i>	Concomitant use of esomeprazole 40 mg resulted in reduced plasma concentrations of the active metabolite of clopidogrel and a reduction in platelet inhibition [see <i>Clinical Pharmacology (12.3)</i> ].
	There are no adequate combination studies of a lower dose of esomeprazole or a higher dose of clopidogrel in comparison with the approved dose of clopidogrel.
<i>Intervention:</i>	Avoid concomitant use with NEXIUM I.V. Consider use of alternative anti-platelet therapy [see <i>Warnings and Precautions (5.6)</i> ].
<b>Citalopram</b>	
<i>Clinical Impact:</i>	Increased exposure of citalopram leading to an increased risk of QT prolongation [see <i>Clinical Pharmacology (12.3)</i> ].
<i>Intervention:</i>	Limit the dose of citalopram to a maximum of 20 mg per day. See prescribing information for citalopram.
<b>Cilostazol</b>	
<i>Clinical Impact:</i>	Increased exposure of cilostazol and one of its active metabolites (3,4-dihydro-cilostazol) [see <i>Clinical Pharmacology (12.3)</i> ].
<i>Intervention:</i>	Consider reducing the dose of cilostazol to 50 mg twice daily. See prescribing information for cilostazol.
<b>Digoxin</b>	
<i>Clinical Impact:</i>	Potential for increased exposure of digoxin [see <i>Clinical Pharmacology (12.3)</i> ].
<i>Intervention:</i>	Monitor digoxin concentrations and adjust the dose, if needed, to maintain therapeutic drug concentrations. See prescribing information for digoxin.
<b>Drugs Dependent on Gastric pH for Absorption (e.g., iron salts, erlotinib, dasatinib, nilotinib, mycophenolate mofetil, ketoconazole/itraconazole)</b>	
<i>Clinical Impact:</i>	Esomeprazole can reduce the absorption of other drugs due to its effect on reducing intragastric acidity
<i>Intervention:</i>	Mycophenolate mofetil (MMF): Co-administration of omeprazole, of which esomeprazole is an enantiomer, in healthy subjects and in transplant patients receiving MMF has been reported to reduce the exposure to the active metabolite, mycophenolic acid (MPA), possibly due to a decrease in MMF solubility at an increased gastric pH. The clinical relevance of reduced MPA exposure on organ rejection has not been

	established in transplant patients receiving NEXIUM I.V. and MMF. Use NEXIUM I.V. with caution in transplant patients receiving MMF [see <i>Clinical Pharmacology (12.3)</i> ].  See the prescribing information for other drugs dependent on gastric pH for absorption.
<b>Tacrolimus</b>	
<i>Clinical Impact:</i>	Potentially increased exposure of tacrolimus, especially in transplant patients who are intermediate or poor metabolizers of CYP2C19.
<i>Intervention:</i>	Monitor tacrolimus whole blood concentrations and consider reducing the dose, if needed, to maintain therapeutic drug concentrations. See prescribing information for tacrolimus.
<b>Interactions with Investigations of Neuroendocrine Tumors</b>	
<i>Clinical Impact:</i>	Serum chromogranin A (CgA) levels increase secondary to PPI-induced decreases in gastric acidity. The increased CgA level may cause false positive results in diagnostic investigations for neuroendocrine tumors [see <i>Warnings and Precautions (5.9)</i> , <i>Clinical Pharmacology (12.2)</i> ].
<i>Intervention:</i>	Discontinue NEXIUM I.V. at least 14 days before assessing CgA levels and consider repeating the test if initial CgA levels are high. If serial tests are performed (e.g. for monitoring), the same commercial laboratory should be used for testing, as reference ranges between tests may vary.
<b>Interaction with Secretin Stimulation Test</b>	
<i>Clinical Impact:</i>	Hyper-response in gastrin secretion in response to secretin stimulation test, falsely suggesting gastrinoma.
<i>Intervention:</i>	Discontinue NEXIUM I.V. 4 weeks prior to testing [see <i>Clinical Pharmacology (12.2)</i> ]

**Table 6: Clinically Relevant Interactions Affecting Esomeprazole When Co-Administered with Other Drugs**

<b>CYP2C19 or CYP3A4 Inducers</b>	
<i>Clinical Impact:</i>	Decreased exposure of esomeprazole when used concomitantly with strong inducers [see <i>Clinical Pharmacology (12.3)</i> ].
<i>Intervention:</i>	<u>St. John's Wort, rifampin:</u> Avoid concomitant use with NEXIUM I.V. [see <i>Warnings and Precautions (5.8)</i> ].  <u>Ritonavir-containing products:</u> see prescribing information for specific drugs
<b>Voriconazole</b>	
<i>Clinical Impact:</i>	Increased exposure of esomeprazole [see <i>Clinical Pharmacology (12.3)</i> ].
<i>Intervention:</i>	Dose adjustment of NEXIUM I.V. is not normally required.  See prescribing information for voriconazole.

## 8 USE IN SPECIFIC POPULATIONS

### 8.1 Pregnancy

#### Risk Summary

There are no adequate and well-controlled studies with esomeprazole in pregnant women. Esomeprazole is the s-isomer of omeprazole. Available epidemiologic data fail to demonstrate an increased risk of major congenital malformations or other adverse pregnancy outcomes with first trimester omeprazole use. Reproduction studies in rats and rabbits resulted in dose-dependent embryo-lethality at omeprazole doses that were approximately 3.4 to 34 times an oral human dose of 40 mg (based on a body surface area for a 60 kg person).

Teratogenicity was not observed in animal reproduction studies with administration of oral esomeprazole magnesium in rats and rabbits with doses about 68 times and 42 times, respectively, an oral human dose of 40 mg (based on a body

surface area basis for a 60 kg person). Changes in bone morphology were observed in offspring of rats dosed through most of pregnancy and lactation at doses equal to or greater than approximately 34 times an oral human dose of 40 mg. When maternal administration was confined to gestation only, there were no effects on bone physcal morphology in the offspring at any age (*see Data*).

The estimated background risks of major birth defects and miscarriage for the indicated population are unknown. All pregnancies have a background risk of birth defect, loss or other adverse outcomes. In the U.S. general population, the estimated background risk of major birth defects and miscarriage in clinically recognized pregnancies is 2% to 4% and 15% to 20%, respectively.

## Data

### *Human Data*

Esomeprazole is the S-isomer of omeprazole. Four epidemiological studies compared the frequency of congenital abnormalities among infants born to women who used omeprazole during pregnancy with the frequency of abnormalities among infants of women exposed to H<sub>2</sub>-receptor antagonists or other controls.

A population based retrospective cohort epidemiological study from the Swedish Medical Birth Registry, covering approximately 99% of pregnancies, from 1995 to 99, reported on 955 infants (824 exposed during the first trimester with 39 of these exposed beyond first trimester, and 131 exposed after the first trimester) whose mothers used omeprazole during pregnancy. The number of infants exposed in utero to omeprazole that had any malformation, low birth weight, low Apgar score, or hospitalization was similar to the number observed in this population. The number of infants born with ventricular septal defects and the number of stillborn infants was slightly higher in the omeprazole-exposed infants than the expected number in this population.

A population-based retrospective cohort study covering all live births in Denmark from 1996 to 2009, reported on 1,800 live births whose mothers used omeprazole during the first trimester of pregnancy and 837,317 live births whose mothers did not use any proton pump inhibitor. The overall rate of birth defects in infants born to mothers with first trimester exposure to omeprazole was 2.9% and 2.6% in infants born to mothers not exposed to any proton pump inhibitor during the first trimester.

A retrospective cohort study reported on 689 pregnant women exposed to either H<sub>2</sub>-blockers or omeprazole in the first trimester (134 exposed to omeprazole) and 1,572 pregnant women unexposed to either during the first trimester. The overall malformation rate in offspring born to mothers with first trimester exposure to omeprazole, an H<sub>2</sub>-blocker, or were unexposed was 3.6%, 5.5%, and 4.1% respectively.

A small prospective observational cohort study followed 113 women exposed to omeprazole during pregnancy (89% with first trimester exposures). The reported rate of major congenital malformations was 4% in the omeprazole group, 2% in controls exposed to non-teratogens, and 2.8% in disease paired controls. Rates of spontaneous and elective abortions, preterm deliveries, gestational age at delivery, and mean birth weight were similar among the groups.

Several studies have reported no apparent adverse short-term effects on the infant when single dose oral or intravenous omeprazole was administered to over 200 pregnant women as premedication for cesarean section under general anesthesia.

### *Animal Data*

#### *Omeprazole*

Reproductive studies conducted with omeprazole in rats at oral doses up to 138 mg/kg/day (about 34 times an oral human dose of 40 mg on a body surface area basis) and in rabbits at doses up to 69.1 mg/kg/day (about 34 times an oral human dose of 40 mg on a body surface area basis) during organogenesis did not disclose any evidence for a teratogenic potential of omeprazole. In rabbits, omeprazole in a dose range of 6.9 to 69.1 mg/kg/day (about 3.4 to 34 times an oral human dose

of 40 mg on a body surface area basis) administered during organogenesis produced dose-related increases in embryo-lethality, fetal resorptions, and pregnancy disruptions. In rats, dose-related embryo/fetal toxicity and postnatal developmental toxicity were observed in offspring resulting from parents treated with omeprazole at 13.8 to 138.0 mg/kg/day (about 3.4 to 34 times an oral human dose of 40 mg on a body surface area basis), administered prior to mating through the lactation period.

### Esomeprazole

No effects on embryo-fetal development were observed in reproduction studies with esomeprazole magnesium in rats at oral doses up to 280 mg/kg/day (about 68 times an oral human dose of 40 mg on a body surface area basis) or in rabbits at oral doses up to 86 mg/kg/day (about 41 times the human dose on a body surface area basis) administered during organogenesis.

A pre- and postnatal developmental toxicity study in rats with additional endpoints to evaluate bone development was performed with esomeprazole magnesium at oral doses of 14 to 280 mg/kg/day (about 3.4 to 68 times an oral human dose of 40 mg on a body surface area basis). Neonatal/early postnatal (birth to weaning) survival was decreased at doses equal to or greater than 138 mg/kg/day (about 34 times an oral human dose of 40 mg on a body surface area basis). Body weight and body weight gain were reduced and neurobehavioral or general developmental delays in the immediate post-weaning timeframe were evident at doses equal to or greater than 69 mg/kg/day (about 17 times an oral human dose of 40 mg on a body surface area basis). In addition, decreased femur length, width and thickness of cortical bone, decreased thickness of the tibial growth plate and minimal to mild bone marrow hypocellularity were noted at doses equal to or greater than 14 mg/kg/day (about 3.4 times an oral human dose of 40 mg on a body surface area basis). Physeal dysplasia in the femur was observed in offspring of rats treated with oral doses of esomeprazole magnesium at doses equal to or greater than 138 mg/kg/day (about 34 times an oral human dose of 40 mg on a body surface area basis).

Effects on maternal bone were observed in pregnant and lactating rats in a pre- and postnatal toxicity study when esomeprazole magnesium was administered at oral doses of 14 to 280 mg/kg/day (about 3.4 to 68 times an oral human dose of 40 mg on a body surface area basis). When rats were dosed from gestational day 7 through weaning on postnatal day 21, a statistically significant decrease in maternal femur weight of up to 14% (as compared to placebo treatment) was observed at doses equal to or greater than 138 mg/kg/day (about 34 times an oral human dose of 40 mg on a body surface area basis).

A pre- and postnatal development study in rats with esomeprazole strontium (using equimolar doses compared to esomeprazole magnesium study) produced similar results in dams and pups as described above.

A follow up developmental toxicity study in rats with further time points to evaluate pup bone development from postnatal day 2 to adulthood was performed with esomeprazole magnesium at oral doses of 280 mg/kg/day (about 68 times an oral human dose of 40 mg on a body surface area basis) where esomeprazole administration was from either gestational day 7 or gestational day 16 until parturition. When maternal administration was confined to gestation only, there were no effects on bone physeal morphology in the offspring at any age.

## **8.2 Lactation**

### Risk Summary

Esomeprazole is the S-isomer of omeprazole and limited data suggest that omeprazole may be present in human milk. There are no clinical data on the effects of esomeprazole on the breastfed infant or on milk production. The developmental and health benefits of breastfeeding should be considered along with the mother's clinical need for NEXIUM and any potential adverse effects on the breastfed infant from NEXIUM or from the underlying maternal condition.

## 8.4 Pediatric Use

The safety and effectiveness of NEXIUM I.V. have been established in pediatric patients 1 month to 17 years of age for the short-term treatment of GERD with EE, as an alternative to oral therapy when oral NEXIUM is not possible or appropriate.

Use of NEXIUM I.V. in this age group is based on extrapolation of adult efficacy to children and the selection of dose based on exposure-matching of pediatrics to adults supported by the following evidence: a) results observed from a pharmacokinetic (PK) study on NEXIUM I.V. for Injection in pediatric patients, b) predictions from a population PK model comparing I.V. PK data between adult and pediatric patients, and c) relationship between exposure and pharmacodynamic results obtained from adult I.V. and pediatric oral data and d) PK results from adequate and well-controlled studies that supported the approval of NEXIUM I.V. in adults [see [Adverse Reactions \(6.1\)](#), [Clinical Pharmacology \(12.3\)](#), [Clinical Studies \(14.1\)](#)].

The safety and effectiveness of NEXIUM I.V. have not been established in patients less than 1 month of age for the treatment of GERD with EE or for risk reduction of rebleeding of gastric or duodenal ulcer following therapeutic endoscopy.

### Juvenile Animal Data

In a juvenile rat toxicity study, esomeprazole was administered with both magnesium and strontium salts at oral doses about 34 to 68 times a daily human dose of 40 mg based on body surface area. Increases in death were seen at the high dose, and at all doses of esomeprazole, there were decreases in body weight, body weight gain, femur weight and femur length, and decreases in overall growth [see [Nonclinical Toxicology \(13.2\)](#)].

## 8.5 Geriatric Use

In a clinical trial of patients with bleeding gastric or duodenal ulcers, 52% of 375 patients randomized to NEXIUM I.V. were 65 years of age and over. No overall differences in safety and efficacy were observed between the elderly and younger individuals, and other reported clinical experience with NEXIUM I.V. and oral esomeprazole has not identified differences in responses between the elderly and younger patients, but greater sensitivity of some older individuals cannot be ruled out.

## 8.6 Hepatic Impairment

### GERD with EE

Exposure to esomeprazole was increased substantially in patients with severe hepatic impairment (Child-Pugh Class C) but not in patients with mild to moderate hepatic impairment (Child-Pugh Classes A and B) compared to patients with normal liver function [see [Clinical Pharmacology \(12.3\)](#)].

For adult patients, no dosage adjustment is necessary for mild to moderate hepatic impairment. For patients with severe hepatic impairment the maximum recommended dosage is 20 mg once daily [see [Dosage and Administration \(2.3\)](#)].

### Risk Reduction of Rebleeding of Gastric or Duodenal Ulcers following Therapeutic Endoscopy

There are no pharmacokinetic data available for NEXIUM I.V. administered as continuous intravenous administration in patients with hepatic impairment. Exposure to intravenous omeprazole, of which esomeprazole is an enantiomer, increased in patients with all degrees of hepatic impairment compared to subjects with normal liver function [see [Clinical Pharmacology \(12.3\)](#)].

For adult patients, no dosage adjustment of the initial NEXIUM I.V. 80 mg loading dose is necessary for patients with any degree of hepatic impairment. Reduce the rate of the continuous infusion to 6 mg/hour for patients with mild to moderate liver impairment (Child-Pugh Classes A and B) and to 4 mg/hour for patients with severe hepatic impairment (Child-Pugh Class C) [see [Dosage and Administration \(2.3\)](#)].

## 10 OVERDOSAGE

The symptoms described in connection with deliberate NEXIUM overdose (limited experience of doses in excess of 240 mg/day) are transient. Reports of overdosage with omeprazole in humans may also be relevant. Doses ranged up to 2,400 mg (120 times the usual recommended clinical dose). Manifestations were variable, but included confusion, drowsiness, blurred vision, tachycardia, nausea, diaphoresis, flushing, headache, dry mouth, and other adverse reactions similar to those seen at recommended dosages. See the full prescribing information for oral omeprazole for complete safety information. No specific antidote for esomeprazole is known. Since esomeprazole is extensively protein bound, it is not expected to be removed by dialysis. In the event of overdosage, treatment should be symptomatic and supportive.

If over-exposure occurs, call your Poison Control Center at 1-800-222-1222 for current information on the management of poisoning or overdosage.

## 11 DESCRIPTION

The active ingredient in NEXIUM® I.V. (esomeprazole sodium) is (*S*)-5-methoxy-2[[[4-methoxy-3,5-dimethyl-2-pyridinyl)-methyl]sulfinyl]-1 *H*-benzimidazole sodium, a PPI. Esomeprazole is the *S*-isomer of omeprazole, which is a mixture of the *S*- and *R*- isomers. Its empirical formula is C<sub>17</sub>H<sub>18</sub>N<sub>3</sub>O<sub>3</sub>Na with molecular weight of 367.4 g/mol (sodium salt) and 345.4 g/mol (parent compound). Esomeprazole sodium is very soluble in water and freely soluble in ethanol (95%). The structural formula is:

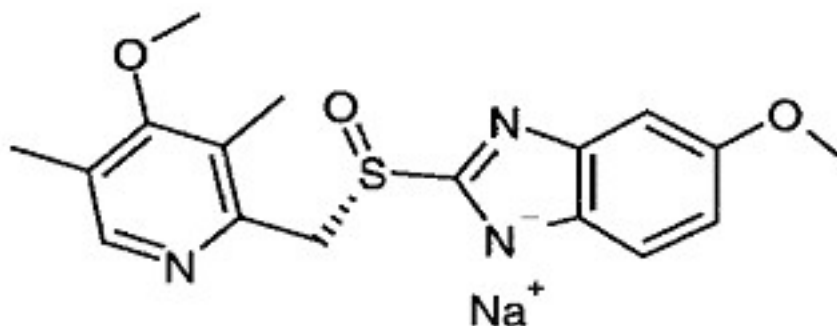

NEXIUM I.V. is supplied as a sterile, lyophilized, white to off-white, porous cake or powder in a 5 mL single-dose vial, intended for intravenous administration after reconstitution with 0.9% Sodium Chloride Injection, USP; Lactated Ringer's Injection, USP or 5% Dextrose Injection, USP. NEXIUM I.V. contains 40 mg esomeprazole (equivalent to 42.5 mg esomeprazole sodium), edetate disodium 1.5 mg and sodium hydroxide q.s. for pH adjustment. The pH of reconstituted solution of NEXIUM I.V. depends on the reconstitution volume and is in the pH range of 9 to 11. The stability of esomeprazole sodium in aqueous solution is strongly pH dependent. The rate of degradation increases with decreasing pH.

## 12 CLINICAL PHARMACOLOGY

### 12.1 Mechanism of Action

Esomeprazole belongs to a class of antisecretory compounds, the substituted benzimidazoles, that suppress gastric acid secretion by specific inhibition of the H<sup>+</sup>/K<sup>+</sup> ATPase enzyme system at the secretory surface of the gastric parietal cell. Esomeprazole is protonated and converted in the acidic compartment of the parietal cell forming the active inhibitor, the achiral sulphenamide. Because this enzyme system is regarded as the acid (proton) pump within the gastric mucosa, esomeprazole has been characterized as a gastric acid-pump inhibitor, in that it blocks the final step of acid production. This effect is dose-related and leads to inhibition of both basal and stimulated acid secretion irrespective of the stimulus.

## 12.2 Pharmacodynamics

### Antisecretory Activity

The effect of esomeprazole on 24-hour intragastric pH in healthy subjects was evaluated in two studies of 20 mg and 40 mg NEXIUM I.V. infused intravenously once daily over 30 minutes for 5 days, as shown in Table 7.

**Table 7: Effect of NEXIUM I.V. on Intragastric pH on Day 5**

	NEXIUM I.V. 20 mg once daily (n=22)	NEXIUM I.V. 40 mg once daily (n=38)
% Time Gastric pH>4 (95% CI)	49.5 41.9–57.2	66.2 62.4–70.0

Gastric pH was measured over a 24-hour period

The effects of esomeprazole on 24-hour intragastric pH following administration of an intravenous infusion of 80 mg NEXIUM.I.V. over 30 minutes followed by a continuous infusion of 8 mg/hour for 23.5 hours was evaluated in two studies.

In *H. pylori*-negative healthy Caucasian subjects (n=24), the % time over 24 hours (95% CI) when the intragastric pH was > 6 and > 7 was 52.3 % (40.3, 64.4) and 4.8 % (1.8, 7.8), respectively.

In *H. pylori*-positive (n=8) and *H. pylori*-negative (n=11) healthy Chinese subjects, the % time over 24 hours (95% CI) when intragastric pH was > 6 and > 7 was 53% (45.6, 60.3) and 15.1% (9.5, 20.7). The percentage of time with intragastric pH > 6 [59% vs. 47%] and with pH > 7 [17% vs. 11%] tended to be larger in the *H. pylori* positive subjects compared to *H. pylori*-negative subjects.

### Serum Gastrin Effects

The effect of esomeprazole on serum gastrin concentrations was evaluated in approximately 2,700 patients in clinical trials of oral esomeprazole for up to 8 weeks and in over 1,300 patients treated for up to 12 months. The mean fasting gastrin level increased in a dose-related manner. The increase in serum gastrin concentrations reached a plateau within two to three months of therapy and returned to baseline levels within four weeks after discontinuation of therapy.

Increased gastrin causes enterochromaffin-like cell hyperplasia and increased serum Chromogranin A (CgA) levels. The increased CgA levels may cause false positive results in diagnostic investigations for neuroendocrine tumors [see [Warnings and Precautions \(5.9\)](#)].

### Enterochromaffin-like (ECL) Cell Effects

There are no data available on the effects of intravenous esomeprazole on ECL cells.

Human gastric biopsy specimens have been obtained from more than 3,000 patients (both children and adults) treated orally with omeprazole in long-term clinical trials. The incidence of ECL cell hyperplasia in these studies increased with time; however, no case of ECL cell carcinoids, dysplasia, or neoplasia has been found in these patients [see [Nonclinical Toxicology \(13.1\)](#)].

In over 1,000 patients treated with oral esomeprazole (10 mg, 20 mg or 40 mg/day) for up to 12 months, the prevalence of ECL cell hyperplasia increased with time and dose. No patient developed ECL cell carcinoids, dysplasia, or neoplasia in the gastric mucosa.

### Endocrine Effects

Esomeprazole had no effect on thyroid function when given in oral doses of 20 mg or 40 mg for 4 weeks. Other effects of esomeprazole on the endocrine system were assessed in studies of omeprazole. Oral doses of omeprazole 30 mg or 40 mg per day for 2 to 4 weeks had no effect on carbohydrate metabolism, circulating levels of parathyroid hormone, cortisol, estradiol, testosterone, prolactin, cholecystokinin or secretin.

## 12.3 Pharmacokinetics

### Absorption

The pharmacokinetics of esomeprazole in healthy subjects following administration of NEXIUM I.V. 20 mg and 40 mg once daily as intravenous infusion over 30 minutes for 5 days are shown in Table 8.

**Table 8: Geometric Mean (95% CI) Pharmacokinetic Parameters of NEXIUM I.V. Following Dosing for 5 Days**

Parameter	NEXIUM I.V.	NEXIUM I.V.
	20 mg (n=24)	40 mg (n=38)
AUC (micromol*h/L)	5.1 (4.0:6.6)	16.2 (14.5:18.2)
C <sub>max</sub> (micromol/L)	3.9 (3.2:4.7)	7.5 (6.9:8.1)
t <sub>1/2</sub> (h)	1.1 (0.9:1.2)	1.4 (1.3:1.5)

Following intravenous administration of NEXIUM I.V. in 24 healthy subjects as a loading dose of 80 mg over 30 minutes followed by a continuous infusion of 8 mg/hour for 23.5 hours (for a total of 24 hours), esomeprazole pharmacokinetic parameters [geometric mean value (95% CI)] were as follows: AUC<sub>t</sub> 111.1 micromol\*h/L (100.5, 122.7 micromol\*h/L), C<sub>max</sub> 15.0 micromol/L (13.5, 16.6 micromol/L), and steady state plasma concentration (C<sub>ss</sub>) 3.9 micromol/L (3.5, 4.5 micromol/L). In another study of healthy Caucasian subjects administered the same treatment regimen.

Esomeprazole is a time-dependent inhibitor of CYP2C19, resulting in autoinhibition and nonlinear pharmacokinetics. The systemic exposure increases in a more than dose proportional manner after multiple oral doses of esomeprazole. Compared to the first dose, the systemic exposure (C<sub>max</sub> and AUC<sub>0-24h</sub>) at steady state following once a day dosing increased by 43% and 90%, respectively, compared to after the first dose for the 20 mg dose and increased by 95% and 159%, respectively, for the 40 mg dose.

### Distribution

Esomeprazole is 97% bound to plasma proteins. Plasma protein binding is constant over the concentration range of 2 to 20 micromol/L. The apparent volume of distribution at steady state in healthy subjects is approximately 16 L.

### Elimination

#### *Metabolism*

Esomeprazole is extensively metabolized in the liver by the cytochrome P450 (CYP) enzyme system. The metabolites of esomeprazole lack antisecretory activity. The major part of esomeprazole's metabolism is dependent upon the CYP2C19 isoenzyme, which forms the hydroxy and desmethyl metabolites. The remaining amount is dependent on CYP3A4 which forms the sulphone metabolite.

#### *Excretion*

Esomeprazole is excreted as metabolites primarily in urine but also in feces. Less than 1% of parent drug is excreted in the urine. Esomeprazole is completely eliminated from plasma, and there is no accumulation during once daily administration. The plasma elimination half-life of esomeprazole following intravenous administration of NEXIUM I.V. is approximately 1.1 to 1.4 hours and is prolonged with increasing doses.

The plasma clearance (CL) is approximately 5.9 to 7.2 L/h during administration of NEXIUM I.V. as an intravenous infusion of 80 mg over 30 minutes followed by a continuous infusion of 8 mg/hour for 23.5 hours.

### Specific Populations

#### *Geriatric Patients*

The AUC and  $C_{\max}$  values of esomeprazole were slightly higher (25% and 18%, respectively) in the elderly as compared to younger subjects at steady state. This increase in exposure is not considered clinically relevant.

#### *Pediatric Patients*

The pharmacokinetics of esomeprazole were evaluated in 50 pediatric patients birth to 17 years of age, inclusive (of which 44 pediatric patients were 1 month to 17 years) in a randomized, open-label, multi-national, multiple dose study of 20 mg NEXIUM I.V. administered as a once-daily 3-minute intravenous injection. Esomeprazole plasma AUC values were 183% and 60% higher in pediatric patients aged 6 to 11 years and 12 to 17 years, respectively, compared to adults.

Subsequent pharmacokinetic analyses predicted the following dosage regimens would achieve comparable steady-state plasma exposures ( $AUC_{0-24}$ ) to those observed in adult patients administered 20 mg of NEXIUM I.V. once daily: 0.5 mg/kg once daily for pediatric patients 1 month to 11 months of age, 10 mg once daily for pediatric patients 1 year to 17 years with body weight less than 55 kg, and 20 mg once daily for pediatric patients 1 year to 17 years with body weight of 55 kg and greater. Increasing the infusion duration from 3 minutes to 10 minutes or 30 minutes was predicted to produce steady-state  $C_{\max}$  values that were comparable to those observed in adult patients at the 40 mg and 20 mg NEXIUM I.V. doses, respectively [see [Use in Specific Populations \(8.4\)](#)].

#### *Male and Female Patients*

The AUC and  $C_{\max}$  values of esomeprazole were slightly higher (13%) in females than in males at steady state when dosed orally. Similar differences have been seen for intravenous administration of esomeprazole. This increase in exposure is not considered clinically relevant.

#### *Patients with Renal Impairment*

The pharmacokinetics of esomeprazole in patients with renal impairment are not expected to be altered relative to healthy subjects as less than 1% of esomeprazole is excreted unchanged in urine.

#### *Patients with Hepatic Impairment*

The steady state pharmacokinetics of esomeprazole obtained after administration of 40 mg orally once daily to 4 patients each with mild (Child-Pugh Class A), moderate (Child-Pugh Class B), and severe (Child-Pugh Class C) hepatic impairment were compared to those obtained in 36 male and female GERD patients with normal liver function. In patients with mild and moderate hepatic impairment, the AUCs were within the range that could be expected in patients with normal liver function. In patients with severe hepatic impairment, the AUCs were 2 to 3 times higher than in the patients with normal liver function. [see [Use in Specific Populations \(8.6\)](#)].

There are no pharmacokinetic data available for esomeprazole administered as continuous intravenous administration in patients with liver impairment. The pharmacokinetics of intravenous omeprazole 80 mg infused over 30 minutes, followed by 8 mg/hour over 47.5 hours in patients with mild (Child-Pugh Class A; n=5), moderate (Child-Pugh Class B; n=4) and severe (Child-Pugh Class C; n=3) liver impairment were compared to those obtained in 24 male and female healthy subjects. In patients with mild and moderate liver impairment, omeprazole clearance and steady state plasma concentration was approximately 35% lower and 50% higher, respectively, than in healthy subjects. In patients with severe liver impairment, the omeprazole clearance was 50% of that in healthy subjects and the steady state plasma concentration was double that in healthy subjects [see [Use in Specific Populations \(8.6\)](#)].

#### Drug Interaction Studies

##### *Effect of Esomeprazole/Omeprazole on Other Drugs*

*In vitro* and *in vivo* studies have shown that esomeprazole is not likely to inhibit CYPs 1A2, 2A6, 2C9, 2D6, 2E1 and 3A4.

##### Antiretrovirals

For some antiretroviral drugs, such as rilpivirine, atazanavir and nelfinavir, decreased serum concentrations have been reported when given together with omeprazole [see [Drug Interactions \(7\)](#)].

#### Rilpivirine:

Following multiple doses of rilpivirine (150 mg, daily) and omeprazole (20 mg, daily), AUC was decreased by 40%,  $C_{max}$  by 40%, and  $C_{min}$  by 33% for rilpivirine [see [Contraindications \(4\)](#)].

#### Nelfinavir:

Following multiple doses of nelfinavir (1250 mg, twice daily) and omeprazole (40 mg daily), AUC was decreased by 36% and 92%,  $C_{max}$  by 37% and 89% and  $C_{min}$  by 39% and 75% respectively for nelfinavir and M8.

#### Atazanavir:

Following multiple doses of atazanavir (400 mg, daily) and omeprazole (40 mg, daily, 2 hours before atazanavir), AUC was decreased by 94%,  $C_{max}$  by 96%, and  $C_{min}$  by 95%.

#### Saquinavir:

Following multiple dosing of saquinavir/ritonavir (1000/100 mg) twice daily for 15 days with omeprazole 40 mg daily co-administered days 11 to 15. The AUC was increased by 82%,  $C_{max}$  by 75%, and  $C_{min}$  by 106%. The mechanism behind this interaction is not fully elucidated.

#### Clopidogrel

In a crossover study, healthy subjects were administered clopidogrel (300 mg loading dose followed by 75 mg per day as the maintenance dosage for 28 days) alone and with esomeprazole (40 mg orally once daily at the same time as clopidogrel) for 29 days. Exposure to the active metabolite of clopidogrel was reduced by 35% to 40% over this time period when clopidogrel and esomeprazole were administered together. Pharmacodynamic parameters were also measured and demonstrated that the change in inhibition of platelet aggregation was related to the change in the exposure to clopidogrel active metabolite [see [Warnings and Precautions \(5.6\)](#), [Drug Interactions \(7\)](#)].

#### Mycophenolate Mofetil

Administration of omeprazole 20 mg twice daily for 4 days and a single 1000 mg dose of MMF approximately one hour after the last dose of omeprazole to 12 healthy subjects in a cross-over study resulted in a 52% reduction in the  $C_{max}$  and 23% reduction in the AUC of MPA [see [Drug Interactions \(7\)](#)].

#### Cilostazol

Omeprazole acts as an inhibitor of CYP2C19. Omeprazole, given in doses of 40 mg daily for one week to 20 healthy subjects in cross-over study, increased  $C_{max}$  and AUC of cilostazol by 18% and 26% respectively. The  $C_{max}$  and AUC of one of the active metabolites, 3,4-dihydro-cilostazol, which has 4-7 times the activity of cilostazol, were increased by 29% and 69%, respectively. Co-administration of cilostazol with omeprazole is expected to increase concentrations of cilostazol and the above mentioned active metabolite [see [Drug Interactions \(7\)](#)].

#### Diazepam

Co-administration of esomeprazole 30 mg and diazepam, a CYP2C19 substrate, resulted in a 45% decrease in clearance of diazepam. Increased plasma levels of diazepam were observed 12 hours after dosing and onwards. However, at that time, the plasma levels of diazepam were below the therapeutic interval, and thus this interaction is unlikely to be of clinical relevance.

#### Digoxin

Concomitant administration of omeprazole 20 mg once daily and digoxin in healthy subjects increased the bioavailability of digoxin by 10% (30% in two subjects) [see [Drug Interactions \(7\)](#)].

#### Other Drugs

Concomitant administration of esomeprazole and either naproxen (non-selective NSAID) did not identify any clinically relevant changes in the pharmacokinetic profiles of these NSAIDs.

### *Effect of Other Drugs on Esomeprazole/Omeprazole*

#### St. John's Wort

In a cross-over study in 12 healthy male subjects, St. John's Wort (300 mg three times daily for 14 days) significantly decreased the systemic exposure of omeprazole in CYP2C19 poor metabolizers ( $C_{\max}$  and AUC decreased by 37.5% and 37.9%, respectively) and extensive metabolizers ( $C_{\max}$  and AUC decreased by 49.6% and 43.9%, respectively) [see *Drug Interactions (7)*].

#### Voriconazole

Concomitant administration of omeprazole and voriconazole (a combined inhibitor of CYP2C19 and CYP3A4) resulted in more than doubling of the omeprazole exposure. When voriconazole (400 mg every 12 hours for one day, followed by 200 mg once daily for 6 days) was given with omeprazole (40 mg once daily for 7 days) to healthy subjects, the steady-state  $C_{\max}$  and AUC<sub>0-24</sub> of omeprazole significantly increased: an average of 2 times (90% CI: 1.8, 2.6) and 4 times (90% CI: 3.3, 4.4), respectively, as compared to when omeprazole was given without voriconazole [see *Drug Interactions (7)*].

#### Other Drugs

Co-administration of esomeprazole with oral contraceptives, diazepam, phenytoin, quinidine, naproxen (non-selective NSAID) did not seem to change the pharmacokinetic profile of esomeprazole.

## 12.4 Microbiology

### Effects on Gastrointestinal Microbial Ecology

Decreased gastric acidity due to any means including proton pump inhibitors, increases gastric counts of bacteria normally present in the gastrointestinal tract. Treatment with proton pump inhibitors may lead to slightly increased risk of gastrointestinal infections such as *Salmonella* and *Campylobacter* and, in hospitalized patients, possibly also *Clostridium difficile*.

## 12.5 Pharmacogenomics

CYP2C19, a polymorphic enzyme, is involved in the metabolism of esomeprazole. The CYP2C19\*1 allele is fully functional while the CYP2C19\*2 and \*3 alleles are nonfunctional. There are other alleles associated with no or reduced enzymatic function. Patients carrying two fully functional alleles are extensive metabolizers and those carrying two loss-of-function alleles are poor metabolizers. The systemic exposure to esomeprazole varies with a patient's metabolism status: poor metabolizers > intermediate metabolizers > extensive metabolizers. Approximately 3% of Caucasians and 15 to 20% of Asians are CYP2C19 poor metabolizers.

Systemic esomeprazole exposures were modestly higher (approximately 17%) in CYP2C19 intermediate metabolizers (IM; n=6) compared to extensive metabolizers (EM; n=17) of CYP2C19. Similar pharmacokinetic differences were noted across these genotypes in a study of Chinese healthy subjects that included 7 EMs and 11 IMs. There is very limited pharmacokinetic information for poor metabolizers (PM) from these studies.

At steady state following once daily administration of NEXIUM I.V. 40 mg, the ratio of AUC in Poor Metabolizers to AUC in the rest of the population (EMs) is approximately 1.5. This change in exposure is not considered clinically meaningful.

## 13 NONCLINICAL TOXICOLOGY

### 13.1 Carcinogenesis, Mutagenesis, Impairment of Fertility

The carcinogenic potential of esomeprazole was assessed using omeprazole studies. In two 24-month oral carcinogenicity studies in rats, omeprazole at daily doses of 1.7, 3.4, 13.8, 44.0, and 140.8 mg/kg/day (about 0.4 to 34 times the human dose of 40 mg/day expressed on a body surface area basis) produced gastric ECL cell carcinoids in a dose-related manner in both male and female rats; the incidence of this effect was markedly higher in female rats, which had higher blood levels of omeprazole. Gastric carcinoids seldom occur in the untreated rat. In addition, ECL cell hyperplasia was present

in all treated groups of both sexes. In one of these studies, female rats were treated with 13.8 mg omeprazole/kg/day (about 3.4 times the human dose of 40 mg/day on a body surface area basis) for 1 year, then followed for an additional year without the drug. No carcinoids were seen in these rats. An increased incidence of treatment-related ECL cell hyperplasia was observed at the end of 1 year (94% treated vs 10% controls). By the second year the difference between treated and control rats was much smaller (46% vs 26%) but still showed more hyperplasia in the treated group. Gastric adenocarcinoma was seen in one rat (2%). No similar tumor was seen in male or female rats treated for 2 years. For this strain of rat no similar tumor has been noted historically, but a finding involving only one tumor is difficult to interpret. A 78-week oral mouse carcinogenicity study of omeprazole did not show increased tumor occurrence, but the study was not conclusive.

Esomeprazole was negative in the Ames mutation test, in the *in vivo* rat bone marrow cell chromosome aberration test, and the *in vivo* mouse micronucleus test. Esomeprazole, however, was positive in the *in vitro* human lymphocyte chromosome aberration test. Omeprazole was positive in the *in vitro* human lymphocyte chromosome aberration test, the *in vivo* mouse bone marrow cell chromosome aberration test, and the *in vivo* mouse micronucleus test.

The potential effects of esomeprazole on fertility and reproductive performance were assessed using omeprazole studies. Omeprazole at oral doses up to 138 mg/kg/day in rats (about 34 times the human dose of 40 mg/day on a body surface area basis) was found to have no effect on reproductive performance of parental animals.

## **13.2 Animal Toxicology and/or Pharmacology**

### Reproduction Studies

Reproduction studies have been performed in rats at oral doses up to 280 mg/kg/day (about 68 times an oral human dose of 40 mg on a body surface area basis) and in rabbits at oral doses up to 86 mg/kg/day (about 42 times an oral human dose of 40 mg on a body surface area basis) and have revealed no evidence of impaired fertility or harm to the fetus due to esomeprazole [see [Use in Specific Populations \(8.1\)](#)].

### Juvenile Animal Study

A 28-day toxicity study with a 14-day recovery phase was conducted in juvenile rats with esomeprazole magnesium at doses of 70 to 280 mg/kg/day (about 17 to 68 times a daily oral human dose of 40 mg on a body surface area basis). An increase in the number of deaths at the high dose of 280 mg/kg/day was observed when juvenile rats were administered esomeprazole magnesium from postnatal day 7 through postnatal day 35. In addition, doses equal to or greater than 140 mg/kg/day (about 34 times a daily oral human dose of 40 mg on a body surface area basis), produced treatment-related decreases in body weight (approximately 14%) and body weight gain, decreases in femur weight and femur length, and affected overall growth. Comparable findings described above have also been observed in this study with another esomeprazole salt, esomeprazole strontium, at equimolar doses of esomeprazole.

## **14 CLINICAL STUDIES**

### **14.1 Acid Suppression in GERD**

Four multicenter, open-label, two-period crossover studies were conducted to compare the pharmacodynamic effects of esomeprazole following intravenous or oral administration on acid suppression in 206 patients with symptoms of GERD with or without erosive esophagitis. Patients were randomized to receive either 20 or 40 mg of NEXIUM I.V. or oral esomeprazole once daily for 10 days (Period 1), and then were switched in Period 2 to the other formulation for 10 days, matching their respective dose from Period 1. NEXIUM I.V. 20 mg and 40 mg was administered as a 3-minute injection in two of the studies and as a 15-minute infusion in the other two studies.

The patient population ranged from 18 to 72 years old; 54% were female; 53% Caucasian, 24% Black, 5% Asian, and 17% other race. Basal acid output (BAO) and maximal acid output (MAO) were determined 22 to 24 hours post-dose on Period 1, Day 11; on Period 2, Day 3; and on Period 2, Day 11. BAO and MAO were estimated from 1-hour continuous collections of gastric contents prior to and following (respectively) subcutaneous injection of 6.0 mcg/kg of pentagastrin.

In these studies, after 10 days of once daily administration, NEXIUM I.V. 20 mg and 40 mg were similar to the corresponding oral dosage of esomeprazole in their ability to suppress BAO and MAO in these GERD patients (see Table 9 below).

There were no major changes in acid suppression when switching between intravenous and oral dosage forms.

**Table 9: Mean (SD) BAO and MAO Measured 22 to 24 Hours Post-Dose Following Once Daily Oral and Intravenous Administration of Esomeprazole for 10 days in GERD Patients with or without a History of EE**

Study	Dose in mg	Intravenous Administration Method	BAO in mmol H <sup>+</sup> /h		MAO in mmol H <sup>+</sup> /h	
			Intravenous	Oral	Intravenous	Oral
1 (N=42)	20	3-minute injection	0.71 (1.24)	0.69 (1.24)	5.96 (5.41)	5.27 (5.39)
2 (N=44)	20	15-minute infusion	0.78 (1.38)	0.82 (1.34)	5.95 (4.00)	5.26 (4.12)
3 (N=50)	40	3-minute injection	0.36 (0.61)	0.31 (0.55)	5.06 (3.90)	4.41 (3.11)
4 (N=47)	40	15-minute infusion	0.36 (0.79)	0.22 (0.39)	4.74 (3.65)	3.52 (2.86)

## 14.2 Bleeding Gastric or Duodenal Ulcers

A randomized, double blind, placebo-controlled clinical study was conducted in 764 patients who presented with endoscopically confirmed gastric or duodenal ulcer bleeding. The population was 18 to 98 years old; 68% were male, 87% Caucasian, 1% Black, 7% Asian, and 4% other race. Following endoscopic hemostasis, patients were randomized to either placebo or NEXIUM I.V. 80 mg as an intravenous infusion over 30 minutes followed by a continuous infusion of 8 mg/hour for a total of 72 hours. After the initial 72-hour period, all patients received an oral PPI for 27 days. The occurrence of rebleeding within 3 days of randomization was 5.9% in the NEXIUM I.V. treated group compared to 10.3% for the placebo group (treatment difference -4.4%; 95% confidence interval: -8.3%, -0.6%; p=0.03). This treatment difference was similar to that observed at Day 7 and Day 30, during which all patients were receiving an oral PPI.

A randomized, double blind, placebo-controlled single-center study conducted in Hong Kong also demonstrated a reduction compared to placebo in the risk of rebleeding within 72 hours in patients with bleeding gastric or duodenal ulcers who received racemic omeprazole, 50% of which is the S-enantiomer esomeprazole.

## 16 HOW SUPPLIED/STORAGE AND HANDLING

NEXIUM I.V. is supplied in a single-dose vial as a as a white to off-white lyophilized powder for reconstitution containing 40 mg of esomeprazole.

NEXIUM I.V. is available as follows:

<u>NDC Number</u>	<u>Strength</u>	<u>Package Size</u>
0186-6040-01	40 mg esomeprazole	10 vials

### Storage

Store at 25°C (77°F); excursions permitted to 15° to 30°C (59° to 86°F). [See USP Controlled Room Temperature.] Protect from light. Store in carton until time of use.

Following reconstitution and administration, discard any unused portion of esomeprazole solution [see *Dosage and Administration* (2.4, 2.5)].

## 17 PATIENT COUNSELING INFORMATION

### Adverse Reactions

Advise patients to report to their healthcare provider if they experience any signs or symptoms consistent with:

- Hypersensitivity Reactions [see [Contraindications \(4\)](#)]
- Acute Interstitial Nephritis [see [Warnings and Precautions \(5.2\)](#)]
- *Clostridium difficile*-Associated Diarrhea [see [Warnings and Precautions \(5.3\)](#)]
- Bone Fracture [see [Warnings and Precautions \(5.4\)](#)]
- Cutaneous and Systemic Lupus Erythematosus [see [Warnings and Precaution \(5.5\)](#)]
- Hypomagnesemia [see [Warnings and Precautions \(5.7\)](#)]

### Drug Interactions

Advise patients to report to their healthcare provider before they start treatment with any of the following:

- Rilpivirine-containing products [see [Contraindications \(4\)](#)]
- Clopidogrel [see [Warnings and Precautions \(5.6\)](#)]
- St. John's Wort or rifampin [see [Warnings and Precautions \(5.8\)](#)]
- High-dose methotrexate [see [Warnings and Precautions \(5.10\)](#)]

### Administration

- Inform patients that antacids may be used while taking NEXIUM I.V.

NEXIUM is a registered trademark of the AstraZeneca group of companies.

Manufactured for:

AstraZeneca Pharmaceuticals LP



Wilmington, DE 19850

© AstraZeneca 2019

Reference ID: 4498689



Reserved area for supplementary printing



(b) (4)

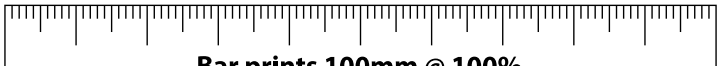

Bar prints 100mm @ 100%

Body text size	Smallest text size
4.0 pt	4.0 pt



**Nexium® IV 40** mg/vial\*  
 (esomeprazole sodium)  
 for Injection

**USUAL ADULT DOSAGE:** See package insert.  
 Store at 25°C (77°F); excursions permitted to 15–30°C (59–86°F).  
 [See USP Controlled Room Temperature.]  
 Protect from light. Store in carton until time of use.

Manufactured for: AstraZeneca Pharmaceuticals LP Wilmington, DE 19850  
 By: AstraZeneca AB, SE 151-85 Södertälje, Sweden  
 Product of Sweden  
 NEXIUM is a registered trademark of the  
 AstraZeneca group of companies.  
 © AstraZeneca 2019



**Nexium® IV 40** mg/vial\*  
 (esomeprazole sodium)  
 for Injection

**10**  
 Single-Dose  
 Vials

Discard unused portion.  
 Rx only

Each single-dose vial contains 40 mg esomeprazole (equivalent to 42.5 mg esomeprazole sodium),  
 excipient of sodium 1.3 mg and sodium hydroxide for pH adjustment.

AstraZeneca

GTIN  
 LOT  
 EXP MM/YYYY  
 SN

AREA FOR LASERPRINTING  
 COLOURED SOLID BLACK

Reserved area to  
 be left without lacquer



Reserved area

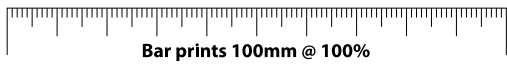

Bar prints 100mm @ 100%

Body text size	Smallest text size
5.86 pt	5.86 pt

-----  
**This is a representation of an electronic record that was signed electronically. Following this are manifestations of any and all electronic signatures for this electronic record.**  
-----

/s/  
-----

JOYCE A KORVICK  
09/30/2019 10:46:48 AM