

**CENTER FOR DRUG EVALUATION AND
RESEARCH**

APPLICATION NUMBER:

214770Orig1s000

MULTI-DISCIPLINE REVIEW

Summary Review

Office Director

Cross Discipline Team Leader Review

Clinical Review

Non-Clinical Review

Statistical Review

Clinical Pharmacology Review

NDA Multi-disciplinary Review and Evaluation, sNDA 205596, sNDA 205053, NDA 214770
 NOXAFIL® (posaconazole) injection, delayed release tablet, PowderMix
 For prophylaxis of invasive fungal infections in pediatric patients 2 years of age and older
 For treatment of invasive aspergillosis in adults and pediatric patients 13 years and older

sNDA/NDA Multi-Disciplinary Review and Evaluation

Application Types	NDA, Efficacy Supplement
Application Number(s)	NDA 214770, NDA 205596/S-012, NDA 205053/S-012, NDA 205596/S-013, NDA 205053/S-011
Priority or Standard	Standard
Submit Date(s)	July 31, 2020 ~ NDA 214770, NDA 205596/S-012, NDA 205053/S-012 August 19, 2020 ~ NDA 205596/S-013, NDA 205053/S-011
Received Date(s)	Same as above
PDUFA Goal Date	May 31, 2021 (NDA 214770, NDA 205596/S-012, NDA 205053/S-012; June 19, 2021 (NDA 205596/S-013, NDA 205053/S-011) May 31, 2021 (target for all applications)
Division/Office	DAI/OID
Review Completion Date	May 28, 2021
Established/Proper Name	Posaconazole
Trade Name	Noxafil®
Pharmacologic Class	Azole antifungal
Applicant	Merck Sharp and Dohme Corporation
Dosage forms	Injection, delayed-release tablet, for delayed-release oral suspension (PowderMix)
Applicant proposed Dosing Regimen	<ol style="list-style-type: none"> 1. <i>Prophylaxis of invasive Aspergillus and Candida infections in pediatric patients 2-<18 years</i> <ol style="list-style-type: none"> a. <u>Injection</u>: 6mg/kg (maximum 300mg) twice a day on the first day and 6 mg/kg (maximum 300mg) daily starting on the second day; b.  (b) (4) c. <u>Delayed release tablet</u>: 300mg twice a day on the first day followed 300 mg daily, starting on the second day for pediatric patients >40 kg. 2. <i>Treatment of Invasive Aspergillosis in patients ≥ 13 years of age</i> <u>Injection, delayed-release tablets</u>: 300 mg twice a day on the first day, followed by 300 mg once a day, starting on the second day.
Applicant Proposed Indication(s)/Population(s)	<ol style="list-style-type: none"> 1. <i>Prophylaxis of invasive Aspergillus and Candida infections in pediatric patients 2 to <18 years of age</i> 2. <i>Treatment of invasive aspergillosis with Noxafil injection or delayed-release tablets in adults and pediatric patients in patients 13 years of age and older</i>
Applicant Proposed SNOMED CT Indication	12391000132109 Invasive fungal infection (disorder)

NDA Multi-disciplinary Review and Evaluation, sNDA 205596, sNDA 205053, NDA 214770
 NOXAFIL® (posaconazole) injection, delayed release tablet, PowderMix
 For prophylaxis of invasive fungal infections in pediatric patients 2 years of age and older
 For treatment of invasive aspergillosis in adults and pediatric patients 13 years and older

Disease Term for each Proposed Indication																						
Recommendation on Regulatory Action	Approval																					
Recommended Indication(s)/Population(s) (if applicable)	<ol style="list-style-type: none"> 1. <i>Prophylaxis of invasive Aspergillus and Candida infections in pediatric patients 2 to <18 years of age</i> 2. <i>Treatment of invasive aspergillosis with Noxafil injection or delayed-release tablets in adults and pediatric patients aged 13 years of age and older</i> 																					
Recommended SNOMED CT Indication Disease Term for each Indication (if applicable)																						
Recommended Dosing Regimen	<ol style="list-style-type: none"> 1. <i>Prophylaxis of invasive Aspergillus and Candida infections for pediatric patients 2-<18 years</i> <ol style="list-style-type: none"> a. <u>Injection</u>: 6mg/kg (maximum 300mg) twice a day on the first day followed by 6 mg/kg (maximum 300mg) daily starting on the second day; b. <u>PowderMix</u> for pediatric patients ≤40kg: <table border="1" data-bbox="540 1003 1409 1381"> <thead> <tr> <th>Weight (kg)</th> <th>Loading Dose (volume) twice daily on the first day</th> <th>Maintenance Dose (volume) daily</th> </tr> </thead> <tbody> <tr> <td>10 to less than 12</td> <td>90 mg (3 mL)</td> <td>90 mg (3 mL)</td> </tr> <tr> <td>12 to less than 17</td> <td>120 mg (4 mL)</td> <td>120 mg (4 mL)</td> </tr> <tr> <td>17 to less than 21</td> <td>150 mg (5 mL)</td> <td>150 mg (5 mL)</td> </tr> <tr> <td>21 to less than 26</td> <td>180 mg (6 mL)</td> <td>180 mg (6 mL)</td> </tr> <tr> <td>26 to less than 36</td> <td>210 mg (7 mL)</td> <td>210 mg (7 mL)</td> </tr> <tr> <td>36 to 40</td> <td>240 mg (8 mL)</td> <td>240 mg (8 mL)</td> </tr> </tbody> </table> c. <u>Delayed release tablet</u>: 300mg twice a day on the first day followed 300 mg once a day, starting on the second day for pediatric patients >40 kg 2. <i>Invasive Aspergillosis</i> <u>Injection, Delayed release tablets</u>: 300 mg twice a day on the first day, followed by 300 mg daily starting on the second day. 	Weight (kg)	Loading Dose (volume) twice daily on the first day	Maintenance Dose (volume) daily	10 to less than 12	90 mg (3 mL)	90 mg (3 mL)	12 to less than 17	120 mg (4 mL)	120 mg (4 mL)	17 to less than 21	150 mg (5 mL)	150 mg (5 mL)	21 to less than 26	180 mg (6 mL)	180 mg (6 mL)	26 to less than 36	210 mg (7 mL)	210 mg (7 mL)	36 to 40	240 mg (8 mL)	240 mg (8 mL)
Weight (kg)	Loading Dose (volume) twice daily on the first day	Maintenance Dose (volume) daily																				
10 to less than 12	90 mg (3 mL)	90 mg (3 mL)																				
12 to less than 17	120 mg (4 mL)	120 mg (4 mL)																				
17 to less than 21	150 mg (5 mL)	150 mg (5 mL)																				
21 to less than 26	180 mg (6 mL)	180 mg (6 mL)																				
26 to less than 36	210 mg (7 mL)	210 mg (7 mL)																				
36 to 40	240 mg (8 mL)	240 mg (8 mL)																				

Table of Contents

Table of Tables	6
Table of Figures.....	10
Reviewers of Multi-Disciplinary Review and Evaluation	11
Glossary.....	16
1 Executive Summary	18
1.1. Product Introduction.....	18
1.2. Conclusions on the Substantial Evidence of Effectiveness	18
1.2.1. Prophylaxis of Invasive Fungal Infections, Pediatric Patients 2 years and older	18
1.2.2. Invasive Aspergillosis Treatment, Adults and Pediatric Patients 13 years and older	20
1.3. Benefit-Risk Assessment Summary.....	21
1.3.1. Prophylaxis of Invasive Fungal Infections, Pediatric Patients 2 years and older	21
1.3.2. Invasive Aspergillosis, Adults and Pediatric Patients 13 years and older.....	23
1.4. Patient Experience Data.....	27
2 Therapeutic Context	28
2.1. Analysis of Condition.....	28
2.1.1. Prophylaxis of Invasive Fungal Infections, Pediatric Patients 2 years and older	28
2.1.2. Invasive Aspergillosis, Adults and Pediatric Patients 13 years and older.....	28
2.2. Analysis of Current Treatment Options	29
2.2.1. Prophylaxis of Invasive Fungal Infections, Pediatric Patients 2 years and older	29
2.2.2. Invasive Aspergillosis, Adults and Pediatric Patients 13 years and older.....	30
3 Regulatory Background	31
3.1. U.S. Regulatory Actions and Marketing History.....	31
3.2. Summary of Presubmission/Submission Regulatory Activity	31
3.2.1. Prophylaxis of Invasive Fungal Infections, Pediatric Patients 2 years and older	31
3.2.2. Treatment of Invasive Aspergillosis, Adults and Pediatric Patients 13 years and older	32
4 Significant Issues from Other Review Disciplines Pertinent to Clinical Conclusions on Efficacy and Safety.....	32
4.1. Office of Scientific Investigations (OSI)	32
4.2. Product Quality	33
4.3. Clinical Microbiology	34
4.4. Division of Medication Error Prevention (DMEPA)	35

5	Nonclinical Pharmacology/Toxicology.....	37
5.1.	Executive Summary	37
5.1.1.	Other Toxicology Studies	37
6	Clinical Pharmacology.....	40
6.1.	Executive Summary	40
6.1.1.	Recommendations	41
6.2.	Clinical Pharmacology Questions	42
6.2.1.	Does the clinical pharmacology program provide supportive evidence of effectiveness?	42
6.2.2.	Is the proposed dose regimen appropriate for the patient population for which the indication is being sought?	45
6.2.3.	Is an alternative dose regimen or management strategy required for subpopulations based on intrinsic patient factors?	48
6.2.4.	Are there clinically relevant drug-drug or food-drug interactions, and what is the appropriate management strategy?.....	50
7	Sources of Clinical Data and Review Strategy	53
7.1.	Table of Clinical Studies.....	53
7.2.	Review Strategy.....	54
8	Statistical and Clinical Evaluation	55
8.1.	Assessment of Efficacy for the Prophylaxis of IFIs in Pediatric Patients 2 years of Age and Older	55
8.2.	Review of Relevant Individual Trials Used to Support Efficacy in Invasive Aspergillosis.....	55
8.2.1.	Study P069	55
8.2.2.	Study Results.....	59
8.2.3.	Assessment of Efficacy Across Trials.....	68
8.2.4.	Integrated Assessment of Effectiveness.....	68
8.3.	Statistical Issues	69
9	Clinical Microbiology Review.....	70
9.1.	Nonclinical Microbiology.....	70
9.1.1.	Mechanism of Action	70
9.1.2.	Antibacterial Activity.....	70
9.1.3.	Antibacterial Activity in Animal Models	70
10	Safety Review	72
10.1.	Safety Review Approach.....	72

10.2.	Study P097: A Study of the Safety, Tolerability, and Pharmacokinetics of Intravenous and for Delayed-release Oral Suspension Formulations of Posaconazole in Immunocompromised Pediatric Subjects with Neutropenia	73
10.2.1.	Pediatric Development Rationale: Formulation and Scope of Clinical Program	73
10.2.2.	Sources of Clinical Data	73
10.2.3.	Study Design	74
10.2.4.	Study Results	76
10.2.5.	P032: A Study of the Safety, Tolerance, and Pharmacokinetics of Oral Posaconazole (POS) in Immunocompromised Pediatric Subjects with Neutropenia	62
10.2.6.	Postmarketing Safety of Posaconazole in Pediatric Patients	62
10.3.	Study P069: A Phase 3 Randomized Study of the Efficacy and Safety of Posaconazole versus Voriconazole for the Treatment of Invasive Aspergillosis in Adults and Adolescents..	63
10.3.1.	Review of the Safety Database.....	63
10.3.2.	Adequacy of the safety database	66
10.3.3.	Adequacy of Applicant’s Clinical Safety Assessments	66
10.3.4.	Safety Results.....	67
10.3.5.	Analysis of Submission-Specific Safety Issues	96
10.3.6.	Safety Analyses by Demographic Subgroups	64
10.3.7.	Specific Safety Studies/Clinical Trials	68
10.3.8.	Safety in the Postmarket Setting.....	69
10.3.9.	Integrated Assessment of Safety.....	69
11	Pediatrics	71
12	Labeling Recommendations	102
12.1.	Prescription Drug Labeling	102
12.2.	Other Prescription Drug Labeling.....	103
13	Risk Evaluation and Mitigation Strategies (REMS)	104
14	Postmarketing Requirements and Commitment	105
15	Appendices	106
15.1.	Financial Disclosure	106
15.2.	OCP Appendices (Technical documents supporting OCP recommendations)	109
15.2.1.	Individual Study Reviews	109
15.2.4.	Pharmacometrics Review	113
15.3.	Additional Clinical Analyses	128
15.3.1.	Study P069 – Additional Tables	128

Table of Tables

Table 2-1 Summary of Treatment Armamentarium for Invasive Aspergillosis in US	30
Table 4-1: Clinical Microbiology Summary, Study 069: <i>Aspergillus</i> spp. in the Posaconazole and Voriconazole treatment arms	34
Table 4-2: Activity of Posaconazole tested against Selected <i>Aspergillus</i> species using CLSI broth Microdilution method.....	35
Table 6-1. Summary of OCP Recommendations & Comments on Key Review Issues (IFI).	41
Table 6-2. Summary of OCP Recommendations & Comments on Key Review Issues (IA).....	42
Table 6-3. Quartile Analysis of Exposure-Response Relationship for Posaconazole in HSCT Recipients Receiving Immunosuppressive Therapy for GVHD	43
Table 6-4. Simulation of (b) (4) Dose Regimen in Pediatric Patients Administered POS POWDERMIX or IV.	46
Table 6-5. Agency-Proposed POS POWDERMIX Dose and PK Target Attainment.	47
Table 6-6. POS Exposure in Study P069 in Adult and Pediatric Patients >13 Years Administered POS IVI or DRT Only.	49
Table 6-7. Simulated POS Exposure in Pediatric Patients Relative to PK Target for IA.	49
Table 6-8. Effect of Food on POS pPOWDERMIX PK.	50
Table 7-1 Study MK-5592-097	53
Table 7-2 Study MK-5592-069	55
Table 8-1: Global Clinical Response Definitions from the 2008 MSG/EORTC Guidelines	57
Table 8-2: Analysis Populations	60
Table 8-3: Subject Disposition (ITT Population).....	60
Table 8-4: Protocol Deviations (ITT Population).....	61
Table 8-5: Demographic and Baseline Characteristics (ITT Population).....	61
Table 8-6 : Characterization of Baseline Diagnosis (ITT Population)	62
Table 8-7: Treatment Duration (ITT Population)	63
Table 8-8: All-Cause Mortality through Day 42	64
Table 8-9: All-Cause Mortality at Day 42 for Various Subgroups (ITT population)	65
Table 8-10: All-cause Mortality through Day 84.....	66
Table 8-11: Global Clinical Response at Week 6 and Week 12 FAS Population	68
Table 10-1 Disposition of Study Subjects.....	77
Table 10-2 Baseline Characteristics All Subjects as Treated	79
Table 10-3: Summary of Adverse Events by Age and Dose Cohorts	42
Table 10-4 Serious Adverse Events listed by PT in Descending Order of Incidence in 6mg/kg Dose Cohort	44
Table 10-5 TEAEs leading to Study Drug Discontinuation	47

Table 10-6 Treatment Emergent Adverse by Age Group Leading to Study Drug Discontinuation (Pooled Analysis, for 6 mg/kg Dose Cohort)	48
Table 10-7 Summary of TEAEs by Maximum Severity-Toxicity by Dose Cohort occurring in >5% of Study Subjects.....	50
Table 10-8 TEAEs by pooled Preferred Term and Dose and Age Cohort in > 5% Study Subjects	52
Table 10-9 TEAEs by Pooled Preferred Terms in 6mg/kg Dose Cohort occurring in > 5% of Study Subjects.....	54
Table 10-10 TEAEs by Preferred Term Occurring in > 5% of Study Subjects, P097	54
Table 10-11 Change from Baseline, ALT	56
Table 10-12 Change from Baseline, AST	56
Table 10-13 Change from Baseline, Total Bilirubin	57
Table 10-14 Change from Baseline, Hyponatremia.....	57
Table 10-15 Change from Baseline, Hypokalemia	58
Table 10-16 Changes from Baseline, Hyperkalemia	59
Table 10-17 Change from Baseline, Hypomagnesemia	59
Table 10-18 Change from Baseline, Hypermagnesemia.....	59
Table 10-19 Change from Baseline, Creatinine	60
Table 10-20 Change from Baseline, Hemoglobin	61
Table 10-21 Change from Baseline, Thrombocytopenia	61
Table 10-22 Study P069: Synopsis of Trial Design	63
Table 10-23 Study 069: Treatment Duration by Treatment Arm - Safety Population	64
Table 10-24 Study P069: Duration of Exposure to Study Drugs (IV and Oral) – Safety Population	65
Table 10-25 Study P069: Disposition of Study Subjects in the Safety Population	65
Table 10-26 Study P069: Summary of Treatment Emergent Adverse Events	67
Table 10-27 Study P069: Deaths from Study Day 1 through Day 114*	68
Table 10-28 Study P069: Causes of Death Occurring in ≥ 0.5% Subjects in Safety Population....	69
Table 10-29 Study P069: Attribution of deaths by CAC* through end of trial	70
Table 10-30 Study P069: Serious adverse events occurring ≥ 1% subjects in Safety Population	72
Table 10-31 P069: Summary of Subjects with Drug-Related SAEs - Posaconazole	74
Table 10-32 Study P069: Treatment Emergent Adverse Events by System Organ Class occurring at ≥ 5% - Safety Population.....	75
Table 10-33 Study P069: Treatment Emergent Adverse Events occurring at rate ≥ 10% - Safety Population.....	78
Table 10-34 Study P069: Outcome Status of TEAEs in Study Subjects.....	80
Table 10-35 Study P069: Outcome Status of TEAEs	80
Table 10-36 Study P069: Drug-Related TEAEs	81
Table 10-37 Study P069: TEAEs Resulting in Discontinuation of Study Drugs.....	82
Table 10-38 Study P069: Hepatic Laboratory Findings that Met Predetermined Criteria	84
Table 10-39: Changes in Liver Test Results from CTC Grade 0, 1, or 2 at Baseline to Grade 3 or 4	85
Table 10-40 Study P069: Posaconazole - Baseline to Maximum Post Baseline Shifts.....	86

Table 10-41 Study P069: Voriconazole - Baseline to Maximum Post Baseline Shifts in ALT Level Category	86
Table 10-42 Study P069: Posaconazole - Baseline to Maximum Post Baseline Shifts in Total Bilirubin Level Category	87
Table 10-43 Study P069: Voriconazole - Baseline to Maximum Post Baseline Shifts in Total Bilirubin Level Category	87
Table 10-44 Study P069: Posaconazole - Baseline to Maximum Post Baseline Shifts in ALP Level Category	87
Table 10-45 Study P069: Voriconazole - Baseline to Maximum Post Baseline Shifts in ALP Level Category	88
Table 10-46 Study P069: Baseline to Maximum Post Baseline Shifts in Creatinine* mg/dL.....	89
Table 10-47 Study P069: Baseline to Maximum Post Baseline Shifts in GFR* mL/min.....	89
Table 10-48 Study P069: Hematology Laboratory Findings	91
Table 10-49 P069: Potassium levels and CTC Grades	92
Table 10-50 Study P069: Laboratory CTC Grade Changes in Potassium from Baseline Levels to Worst during Treatment	92
Table 10-51 Mean Change (SD) in Pulse Rate from Baseline over Time in Treatment Phase for POS and VOR Treatment Groups	93
Table 10-52 Study P069: Mean Change (SD) In Blood Pressure from Baseline over Time in Treatment Phase for POS and VOR Treatment Groups	94
Table 10-53 Study P069: Mean Changes in ECG Assessment from Baseline over Time	94
Table 10-54 Study P069: QT Interval Measurements.....	95
Table 10-55 Study P069: TEAEs of Special Interest	96
Table 10-56 Study P069: Hepatobiliary Disorders	98
Table 10-57 Study P069: Outcomes Categories for Hepatobiliary Adverse Events	99
Table 10-58 Study P069: Drug-related Hepatic TEAEs.....	99
Table 10-59 Study P069: Characteristics of potential Hy's Law cases in Posaconazole and Voriconazole Groups.....	41
Table 10-60 Study P069: Drug-related TEAEs of Special Interest - Eye, Psychiatric, Endocrine, Neurologic, Skin/Soft Tissue and Vascular Disorders	55
Table 10-61 Study P069: TEAEs in Patients ≥ 65years of Age by Treatment Group.....	65
Table 10-62 Study P069: TEAEs in Male and Female Patients by Treatment Group	66
Table 10-63 Study P069: TEAEs by Race and Treatment Group.....	67
Table 10-64 Study P069: TEAEs by Region/Continent and Treatment Group.....	68
Table 15-1. Relative Bioavailability of 100 mg Posaconazole Administered to 13 Healthy Volunteers as pPOWDERMIX Fasted, pPOWDERMIX Fed, or DRT Fasted.....	109
Table 15-2. Summary of Plasma Steady-State Pharmacokinetic Parameters of Posaconazole After Administration of the Posaconazole IV and Oral Formulations	111
Table 15-3. Summary of Posaconazole Steady-State Average Concentration and PK Target Attainment in Patients After Administration of the Posaconazole IV and Oral Formulations...	112
Table 15-4. Study Included in Applicant's POS PPK Report (IFI).	113
Table 15-5. Parameter Estimates of the Applicant's Final PPK Model (IFI).	114

NDA Multi-disciplinary Review and Evaluation, sNDA 205596, sNDA 205053, NDA 214770
NOXAFIL® (posaconazole) injection, delayed release tablet, PowderMix
For prophylaxis of invasive fungal infections in pediatric patients 2 years of age and older
For treatment of invasive aspergillosis in adults and pediatric patients 13 years and older

Table 15-6. Studies Included in Applicant’s Final PPK Model (IA)	117
Table 15-7. Datasets Used in PPK Analysis (IFI).....	122
Table 15-8. Datasets Used in PPK Analysis (IA).....	122
Table 15-9. Stepwise Selection Process for Food on POS PK.....	123
Table 15-10. Exposure-Response Relationship for Survival by Food Status in Oral Only Patients.	125
Table 15-11 Study P069: Listing of Deaths (N = 197) by Cause of Death and Day of Death	128
Table 15-12 Study P069: TEAEs of Special Interest by Treatment Group	136

Table of Figures

Figure 6-1. Posaconazole Exposure-Response Relationships in HSCT Recipients Receiving Immunosuppressive Therapy for GVHD	43
Figure 6-2. Relationship Between Age and Weight in Pediatric Patients.....	44
Figure 6-3. Relationship Between POS Cavg and Survival in IA.....	48
Figure 8-1: Kaplan-Meier Plot for Cumulative All-Cause Mortality Through Day 114 (ITT Population).....	67
Figure 9-1 The Effect of Posaconazole treatment in two immunocompromised mouse models infected with <i>A. fumigatus</i>	71
Figure 10-1 Study P069: Kaplan-Meier Plot for Cumulative All-Cause Mortality Rate Through Day 114 - Safety Population.....	71
Figure 10-2 Study P069: Safety Risk Assessment for TEAEs in Safety Population.....	79
Figure 10-3 Study P069: Hy's Law Plot during treatment phase* – Safety Population.....	101
Figure 10-4 Study P069: Hy's Law Plot during treatment phase* – Safety Population	102
Figure 15-1. GOF Plots for Applicant's PPK Model (IFI).	115
Figure 15-2. Visual Predictive Check for Applicant's Final PPK Model (IFI).	116
Figure 15-3. Applicant's Final PPK Model Structure (IA).	118
Figure 15-4. Parameter Estimates for Applicant's Final PPK Model (IA).	119
Figure 15-5. GOF Plots for Applicant's PPK Model (IA).....	120
Figure 15-6. Prediction-Corrected Visual Predictive Check for Applicant's Final PPK Model (IA).	121
Figure 15-7. Relationship between Survival and POS Cavg.	124
Figure 15-8. Exposure-Response Relationship for Survival Stratified by Route.	125
Figure 15-9. Exposure-Response Relationship for Global Response Stratified by Route.....	126

NDA Multi-disciplinary Review and Evaluation, sNDA 205596, sNDA 205053, NDA 214770
 NOXAFIL® (posaconazole) injection, delayed release tablet, PowderMix
 For prophylaxis of invasive fungal infections in pediatric patients 2 years of age and older
 For treatment of invasive aspergillosis in adults and pediatric patients 13 years and older

Reviewers of Multi-Disciplinary Review and Evaluation

Regulatory Project Manager	Christopher Smith, PharmD
Nonclinical Reviewer	Owen McMaster, PhD
Nonclinical Team Leader	Terry Miller, PhD
Office of Clinical Pharmacology Reviewer(s)	Jason Moore, PharmD
Office of Clinical Pharmacology Team Leader(s)	Dakshina Chilukuri, PhD
Clinical Reviewer	Elizabeth O'Shaughnessy, MD
Clinical Reviewer	Amy Bishara, MD
Clinical Team Leader	Yuliya Yasinskaya, MD
Statistical Reviewer	Cheryl Dixon, PhD
Statistical Team Leader	Karen Higgins, ScD
Cross-Disciplinary Team Leader	Yuliya Yasinskaya, MD
Division Director (OCP)	Kellie Reynolds, PharmD

Additional Reviewers of Application

OPQ	Grace Chiou, PhD Dorota Matecka, PhD (Team Leader)
Microbiology	Lynette Berkeley, PhD Avery Goodwin, PhD (Team Leader)
OPDP	Dave Foss, PharmD
OSI	Christian Shenouda, MD Philip Kronstein, MD (Team Leader)
OSE/DEPI	Mingfeng Zhang, MD, PhD Natasha Pratt, PhD (Team Leader)
OSE/DMEPA	Cameron Johnson, PharmD Deborah Myers, PharmD Ebony Whaley, MD (acting Team Leader) Otto Townsend, PharmD (Team Leader)

OPQ=Office of Pharmaceutical Quality
 OPDP=Office of Prescription Drug Promotion
 OSI=Office of Scientific Investigations
 OSE= Office of Surveillance and Epidemiology
 DEPI= Division of Epidemiology
 DMEPA=Division of Medication Error Prevention and Analysis
 DRISK=Division of Risk Management

NDA Multi-disciplinary Review and Evaluation, sNDA 205596, sNDA 205053, NDA 214770
 NOXAFIL® (posaconazole) injection, delayed release tablet, PowderMix
 For prophylaxis of invasive fungal infections in pediatric patients 2 years of age and older
 For treatment of invasive aspergillosis in adults and pediatric patients 13 years and older

Signatures

DISCIPLINE	REVIEWER	OFFICE/DIVISION	SECTIONS AUTHORED/ APPROVED	AUTHORED/ APPROVED
Nonclinical Reviewer	Owen McMaster, Ph.D.	Office of Antimicrobial Products/Division of Pharmacology/Toxicology for Infectious Diseases	Section: 5	Select one: <input checked="" type="checkbox"/> Authored <input type="checkbox"/> Approved
	Signature: Owen G. McMaster -S <small>Digitally signed by Owen G. McMaster -S DN: c=US, o=U.S. Government, ou=HHS, ou=FDA, ou=People, 0.9.2342.19200300.100.1.1=1300085286, cn=Owen G. McMaster -S Date: 2021.05.28 15:01:40 -04'00'</small>			
Nonclinical Supervisor	Terry J. Miller, Ph.D.	Office of Antimicrobial Products/Division of Pharmacology/Toxicology for Infectious Diseases	Section: 5	Select one: <input checked="" type="checkbox"/> Authored <input checked="" type="checkbox"/> Approved
	Signature: Terry J. Miller -S <small>Digitally signed by Terry J. Miller -S DN: c=US, o=U.S. Government, ou=HHS, ou=FDA, ou=People, 0.9.2342.19200300.100.1.1=1300233444, cn=Terry J. Miller -S Date: 2021.05.28 12:07:54 -04'00'</small>			
Clinical Pharmacology Reviewer	Jason Moore, PharmD	OCP	Sections: 6, 15.2	Select one: <input checked="" type="checkbox"/> Authored <input type="checkbox"/> Approved
	Signature: Jason N. Moore Jr -S <small>Digitally signed by Jason N. Moore Jr -S DN: c=US, o=U.S. Government, ou=HHS, ou=FDA, ou=People, 0.9.2342.19200300.100.1.1=2001404935, cn=Jason N. Moore Jr -S Date: 2021.05.28 11:43:36 -04'00'</small>			
Clinical Pharmacology Team Leader	Dakshina Chilukuri, PhD	OCP	Section: 6, 15.2	Select one: <input type="checkbox"/> Authored <input checked="" type="checkbox"/> Approved
	Signature: Dakshina M. Chilukuri -S <small>Digitally signed by Dakshina M. Chilukuri -S DN: c=US, o=U.S. Government, ou=HHS, ou=FDA, ou=People, 0.9.2342.19200300.100.1.1=1300188261, cn=Dakshina M. Chilukuri -S Date: 2021.05.28 12:19:19 -04'00'</small>			
Pharmacometrics Team Leader	Justin Earp, PhD	OCP	Section: 6, 15.2	Select one: <input type="checkbox"/> Authored <input checked="" type="checkbox"/> Approved
	Signature: Justin C. Earp -S <small>Digitally signed by Justin C. Earp -S DN: c=US, o=U.S. Government, ou=HHS, ou=FDA, ou=People, cn=Justin C. Earp -S, 0.9.2342.19200300.100.1.1=1300436664 Date: 2021.05.28 13:29:00 -04'00'</small>			

NDA Multi-disciplinary Review and Evaluation, sNDA 205596, sNDA 205053, NDA 214770
 NOXAFIL® (posaconazole) injection, delayed release tablet, PowderMix
 For prophylaxis of invasive fungal infections in pediatric patients 2 years of age and older
 For treatment of invasive aspergillosis in adults and pediatric patients 13 years and older

DISCIPLINE	REVIEWER	OFFICE/DIVISION	SECTIONS AUTHORED/ APPROVED	AUTHORED/ APPROVED
Clinical Reviewer	Amy Bishara, MD	DAI	Sections: 1.2.1, 1.3.1, 2.1.1, 2.2.1, 11, 15.1	Select one: <input type="checkbox"/> <u>v</u> <input type="checkbox"/> <u>x</u> <input type="checkbox"/> <u> </u> Authored Authored Approved
	Signature: signed on behalf of Amy Bishara, MD Yuliya I. Yasinskaya -S <small>Digitally signed by Yuliya I. Yasinskaya -S DN: c=US, o=U.S. Government, ou=HHS, ou=FDA, ou=People, 0.9.2342.19200300.100.1.1=1300376979, cn=Yuliya I. Yasinskaya -S Date: 2021.05.28 14:26:52 -04'00'</small>			
Clinical Reviewer	Elizabeth O'Shaughnessy, MD	DAI	Sections: 1.2.2, 1.3.2, 2.1.2, 2.2.2, 4.1, 7, 10, 15.1, 15.3	Select one: <input type="checkbox"/> <u>v</u> <input type="checkbox"/> <u>x</u> <input type="checkbox"/> <u> </u> Authored Authored Approved
	Signature: Elizabeth M. Oshaughnessy -S <small>Digitally signed by Elizabeth M. Oshaughnessy -S DN: c=US, o=U.S. Government, ou=HHS, ou=FDA, ou=People, 0.9.2342.19200300.100.1.1=1300364622, cn=Elizabeth M. Oshaughnessy -S Date: 2021.05.28 13:56:01 -04'00'</small>			
Clinical Team Leader	Elizabeth O'Shaughnessy, MD Yuliya Yasinskaya, MD	DAI	Sections: 1-15	Select one: <input type="checkbox"/> <u>v</u> <input checked="" type="checkbox"/> <u>x</u> <input type="checkbox"/> <u> </u> Authored Approved
	Signature: Yuliya I. Yasinskaya -S <small>Digitally signed by Yuliya I. Yasinskaya -S DN: c=US, o=U.S. Government, ou=HHS, ou=FDA, ou=People, 0.9.2342.19200300.100.1.1=1300376979, cn=Yuliya I. Yasinskaya -S Date: 2021.05.28 14:24:25 -04'00'</small>			
Clinical Microbiology reviewer	Lynette Berkeley, PhD	DAI	Sections: 4.3, 9	Select one: <input type="checkbox"/> <u>v</u> <input type="checkbox"/> <u>x</u> <input type="checkbox"/> <u> </u> Authored Approved
	Signature: Avery C. Goodwin -S <small>Digitally signed by Avery C. Goodwin -S DN: c=US, o=U.S. Government, ou=HHS, ou=FDA, ou=People, 0.9.2342.19200300.100.1.1=1300211785, cn=Avery C. Goodwin -S Date: 2021.05.28 11:59:08 -04'00'</small>			
Clinical Microbiology Team Leader	Avery Goodwin, PhD	DAI	Sections: 4.3, 9	Select one: <input type="checkbox"/> <u>v</u> <input type="checkbox"/> <u>x</u> <input type="checkbox"/> <u> </u> Authored Approved
	Signature: Avery C. Goodwin -S <small>Digitally signed by Avery C. Goodwin -S DN: c=US, o=U.S. Government, ou=HHS, ou=FDA, ou=People, 0.9.2342.19200300.100.1.1=1300211785, cn=Avery C. Goodwin -S Date: 2021.05.28 11:59:54 -04'00'</small>			

NDA Multi-disciplinary Review and Evaluation, sNDA 205596, sNDA 205053, NDA 214770
 NOXAFIL® (posaconazole) injection, delayed release tablet, PowderMix
 For prophylaxis of invasive fungal infections in pediatric patients 2 years of age and older
 For treatment of invasive aspergillosis in adults and pediatric patients 13 years and older

DISCIPLINE	REVIEWER	OFFICE/DIVISION	SECTIONS AUTHORED/ APPROVED	AUTHORED/ APPROVED
Statistical Reviewer	Cheryl Dixon, PhD	DAI	Section: 8.2, 8.3	Select one: <input checked="" type="checkbox"/> Authored <input type="checkbox"/> Authored <input type="checkbox"/> Approved
	Signature: Cheryl A. Dixon -S <small>Digitally signed by Cheryl A. Dixon -S DN: c=US, o=U.S. Government, ou=HHS, ou=FDA, ou=People, 0.9.2342.19200300.100.1.1=1300115195, cn=Cheryl A. Dixon -S Date: 2021.05.28 12:27:20 -04'00'</small>			
Statistical Team Leader	Karen Higgins, ScD	DAI	Section: 8.2, 8.3	Select one: <input type="checkbox"/> <input checked="" type="checkbox"/> Authored <input type="checkbox"/> Approved
	Signature: Karen M. Higgins -S <small>Digitally signed by Karen M. Higgins -S DN: c=US, o=U.S. Government, ou=HHS, ou=FDA, ou=People, 0.9.2342.19200300.100.1.1=1300117310, cn=Karen M. Higgins -S Date: 2021.05.28 11:47:40 -04'00'</small>			
Division Director (Clinical)	Sumathi Nambiar, MD	DAI	Sections: 1-15	Select one: <input type="checkbox"/> Authored <input checked="" type="checkbox"/> <input checked="" type="checkbox"/> Authored <input type="checkbox"/> Approved
	Signature:			
Deputy Division Director (Clinical)	Dmitri Iarikov, MD, PhD	DAI	Sections: 1-15	Select one: <input type="checkbox"/> <input checked="" type="checkbox"/> Authored <input type="checkbox"/> Approved
	Signature: Dmitri E. Iarikov -S <small>Digitally signed by Dmitri E. Iarikov -S DN: c=US, o=U.S. Government, ou=HHS, ou=FDA, ou=People, 0.9.2342.19200300.100.1.1=2000351806, cn=Dmitri E. Iarikov -S Date: 2021.05.28 13:17:40 -04'00'</small>			
Associate Director for Labeling	Abimbola Adebawale, PhD	DAI	Section: 12	Select one: <input checked="" type="checkbox"/> Authored <input type="checkbox"/> Approved
	Signature: Abimbola O. Adebawale -S <small>Digitally signed by Abimbola O. Adebawale -S DN: c=US, o=U.S. Government, ou=HHS, ou=FDA, ou=People, 0.9.2342.19200300.100.1.1=1300141826, cn=Abimbola O. Adebawale -S Date: 2021.05.28 18:11:45 -04'00'</small>			

DISCIPLINE	REVIEWER	OFFICE/DIVISION	SECTIONS AUTHORED/ APPROVED	AUTHORED/ APPROVED
------------	----------	-----------------	-----------------------------	--------------------

NDA Multi-disciplinary Review and Evaluation, sNDA 205596, sNDA 205053, NDA 214770
 NOXAFIL® (posaconazole) injection, delayed release tablet, PowderMix
 For prophylaxis of invasive fungal infections in pediatric patients 2 years of age and older
 For treatment of invasive aspergillosis in adults and pediatric patients 13 years and older

			APPROVED	
Regulatory Project Manager	Christopher Smith, PharmD	DAI	Section: 3	Select one: _v_ Authored Approved
	Signature: Christopher L. Smith -S <small>Digitally signed by Christopher L. Smith -S DN: c=US, ou=U.S. Government ou=HHS ou=FDA ou=People 0 9 2342 19200300 100 1 1-2001246211 cn=Christopher L. Smith -S Date: 2021.05.28 15:42:52 -0400'</small>			
Senior Project Management Staff	Carmen DeBellas, PharmD	DAI	Section: 3	Select one: x Authored Approved
	Signature: Carmen L. Debellas -S <small>Digitally signed by Carmen L. Debellas -S DN: c=US o=U.S. Government ou=HHS ou=FDA ou=People 0 9 2342 19200300 100 1 1 1300060464 cn=Carmen L. Debellas -S Date: 2021.05.28 15:50:35 -0400'</small>			

Glossary

AC	advisory committee
ADME	absorption, distribution, metabolism, excretion
AE	adverse event
AR	adverse reaction
BLA	biologics license application
BPCA	Best Pharmaceuticals for Children Act
BRF	Benefit Risk Framework
CBER	Center for Biologics Evaluation and Research
CDER	Center for Drug Evaluation and Research
CDRH	Center for Devices and Radiological Health
CDTL	Cross-Discipline Team Leader
CFR	Code of Federal Regulations
CMC	chemistry, manufacturing, and controls
CRF	case report form
CRO	contract research organization
CRT	clinical review template
CSR	clinical study report
DMC	data monitoring committee
ECG	electrocardiogram
eCTD	electronic common technical document
ETASU	elements to assure safe use
FDA	Food and Drug Administration
FDAAA	Food and Drug Administration Amendments Act of 2007
FDASIA	Food and Drug Administration Safety and Innovation Act
GCP	good clinical practice
GRMP	good review management practice
HSCT	hematopoietic stem cell transplant
ICH	International Conference on Harmonisation
ICU	intensive care unit
IFI(s)	invasive fungal infection(s)
IND	Investigational New Drug
ISE	integrated summary of effectiveness
ISS	integrated summary of safety
ITT	intent to treat
MedDRA	Medical Dictionary for Regulatory Activities
mITT	modified intent to treat
NDA	new drug application
NME	new molecular entity
OCS	Office of Computational Science

NDA Multi-disciplinary Review and Evaluation, sNDA 205596, sNDA 205053, NDA 214770
NOXAFIL® (posaconazole) injection, delayed release tablet, PowderMix
For prophylaxis of invasive fungal infections in pediatric patients 2 years of age and older
For treatment of invasive aspergillosis in adults and pediatric patients 13 years and older

OPQ	Office of Pharmaceutical Quality
OSE	Office of Surveillance and Epidemiology
OSI	Office of Scientific Investigation
PBRER	Periodic Benefit-Risk Evaluation Report
PD	pharmacodynamics
PI	prescribing information
PK	pharmacokinetics
PMC	postmarketing commitment
PMR	postmarketing requirement
PP	per protocol
PPI	patient package insert (also known as Patient Information)
PREA	Pediatric Research Equity Act
PRO	patient reported outcome
PSUR	Periodic Safety Update report
REMS	risk evaluation and mitigation strategy
SAE	serious adverse event
SAP	statistical analysis plan
SGE	special government employee
TEAE	treatment emergent adverse event

1 Executive Summary

1.1. Product Introduction

Posaconazole (MK-5592), a triazole antifungal drug, was developed for the prevention and treatment of invasive fungal infections (IFI). Similar to other triazole drugs, it blocks the synthesis of ergosterol in the fungal cell membrane, through the inhibition of lanosterol 14 α -demethylase and accumulation of methylated sterol precursors. Posaconazole is active against a spectrum of yeasts and molds that are pathogenic to humans.

The oral delayed-release tablet formulation is an approved dosage form and was designed to overcome the poor gastrointestinal absorption of posaconazole immediate-release oral suspension (OS). The tablet combines posaconazole with a pH-sensitive polymer (hypromellose acetate succinate, HPMCAS) via a hot-melt extrusion (HME) process and this approach limits posaconazole absorption in the stomach and maximizes its release in the small intestine.

Posaconazole Injection, posaconazole 18 mg /mL, an intravenous (IV) formulation is an approved dosage form in addition to the approved oral suspension and tablet formulations. The formulation contains sulfobutylether-beta-cyclodextrin (SBE β CD) (b) (4). The drug product is to be diluted in 0.9% saline or 5% dextrose solution prior to administration by IV infusion.

The three formulations are approved for the indications of prophylaxis of IFIs and for the treatment of oropharyngeal candidiasis in the case of the OS. The OS and delayed-release tablet formulations are approved for prophylaxis of IFIs in adults and adolescents \geq 13 years of age, and IV posaconazole is approved in adults greater \geq 18 years of age for these aforementioned indications.

The Applicant has developed a new powder for oral suspension formulation (POWDERMIX) for use in pediatric patients age 2 to less than 18 years old for the prophylaxis of IFIs. The new POWDERMIX formulation was developed as a more tolerable, weight-based dosing alternative to the oral tablet with improved and more reliable bioavailability compared to the OS which failed to meet target systemic exposures in a PK/safety study of three dose cohorts in immunocompromised pediatric patients.

1.2. Conclusions on the Substantial Evidence of Effectiveness

1.2.1. Prophylaxis of Invasive Fungal Infections, Pediatric Patients 2 years and older

The safety and effectiveness of Noxafil have been established in pediatric patients 2 to less than 18 years of age for the prophylaxis of invasive *Aspergillus* and *Candida* infections who are at high risk of developing these infections due to being severely immunocompromised, (e.g. HSCT

NDA Multi-disciplinary Review and Evaluation, sNDA 205596, sNDA 205053, NDA 214770
NOXAFIL® (posaconazole) injection, delayed release tablet, PowderMix
For prophylaxis of invasive fungal infections in pediatric patients 2 years of age and older
For treatment of invasive aspergillosis in adults and pediatric patients 13 years and older

recipients with GVHD or those with hematologic malignancies with prolonged neutropenia from chemotherapy). Use of Noxafil in these age groups is supported by evidence from adequate and well-controlled studies of Noxafil in adult and pediatric patients 13 years and older and additional pharmacokinetic and safety data in pediatric patients 2 years of age and older.

Formal efficacy assessment was not performed in the pediatric Study P097. Extrapolation of efficacy was based on the adequate and well controlled prophylaxis trials in adults and pediatric patients 13 years and older (Studies P01899 and P00041) using comparable PK exposure targets (initially determined by exposure-response analysis of the PK data from adult trials of Noxafil oral suspension, Cavg 700-2500 ng/ml).

The safety profile for Noxafil injection and for delayed release oral suspension in pediatric patients 2-17 years of age is comparable to that of adults who received Noxafil oral suspension, injection or delayed release oral tablet for the prophylaxis of invasive fungal infections with no new safety concerns or prominent dose-(exposure-) or age-related adverse reactions identified. The safety profile for Noxafil injection and for POWDERMIX in pediatric patients 2-17 years of age is comparable to that of adults who received Noxafil oral suspension, injection or delayed release oral tablet for the prophylaxis of IFI. No new safety concerns or significant dose-(exposure-) or age-related adverse reactions were identified. The most common adverse reactions (occurring in greater than 20% of pediatric subjects receiving Noxafil 6 mg/kg daily dose) were pyrexia, febrile neutropenia, vomiting, mucosal inflammation, pruritus, hypertension, hypokalemia, and stomatitis.

The safety and effectiveness of Noxafil have not been evaluated in pediatric patients younger than 2 years of age.

Noxafil for delayed release suspension (Noxafil POWDERMIX) contains sorbitol and its use will be contraindicated in patients with known or suspected hereditary fructose intolerance (HFI).

Dosing recommendation for the indication of prophylaxis of IFIs in pediatric patients 2-<18 years of age is derived from the PK data collected in pediatric study P097:

Noxafil Injection: Loading Dose (LD) 6 mg/kg twice daily on day 1 and maintenance dose (MD) 6 mg/kg once daily thereafter up to a maximum dose of 300 mg

For Noxafil PowderMix, a weight band dosing is recommended as follows:

<u>Weight (kg)</u>	<u>LD (volume) x2 daily on Day1</u>	<u>MD (volume) daily</u>
10 to less than 12	90 mg (3 mL)	90 mg (3 mL)
12 to less than 17	120 mg (4 mL)	120 mg (4 mL)
17 to less than 21	150 mg (5 mL)	150 mg (5 mL)
21 to less than 26	180 mg (6 mL)	180 mg (6 mL)
26 to less than 36	210 mg (7 mL)	210 mg (7 mL)

NDA Multi-disciplinary Review and Evaluation, sNDA 205596, sNDA 205053, NDA 214770
NOXAFIL® (posaconazole) injection, delayed release tablet, PowderMix
For prophylaxis of invasive fungal infections in pediatric patients 2 years of age and older
For treatment of invasive aspergillosis in adults and pediatric patients 13 years and older

36 to 40

240 mg (8 mL)

240 mg (8 mL)

Noxafil Delayed Release Tablet is recommended for pediatric patients who weigh more than 40kg: LD 300 mg twice daily on Day 1 and MD 300mg once daily thereafter.

1.2.2. Invasive Aspergillosis Treatment, Adults and Pediatric Patients 13 years and older

The efficacy results in the phase 3 trial, Study MK-5592-069 (hereafter referred to as P069), demonstrate that treatment with posaconazole IV injection or oral delayed-release tablets (POS) at standard doses (300 mg twice daily on Day 1 and thereafter 300 mg once daily) was noninferior to the standard of care, voriconazole IV injection or oral tablets (VOR), with respect to all-cause mortality through Day 42. The all-cause mortality rate through Day 42 in the ITT population was 15.3% in the POS group and 20.6% in the VOR group. The upper bound of the 95% confidence interval of the difference (posaconazole - voriconazole) was 1.0% and lower than the prespecified and justified 10% non-inferiority margin. The results of the secondary endpoint of global clinical response at Week 6 in patients with proven or probable IA by EORTC criteria population was similar between treatment groups (44.8% for POS and 45.6% for VOR) with a 95% confidence interval about the treatment difference of (-11.2%, 10.1%).

Results of Study P069 demonstrated adequate evidence of effectiveness of POS for the treatment of IA in immunocompromised patients with hematological malignancies. See section 8 for the efficacy analyses. Posaconazole delayed release tablets and IV injection at standard doses are additional options for treatment of invasive aspergillosis. Other antifungal azoles (voriconazole, isavuconazonium, itraconazole) are effective for the treatment of invasive aspergillosis and are recommended as first line options, with voriconazole as the primary option, in current clinical treatment guidelines.¹³

1.3. Benefit-Risk Assessment Summary

1.3.1. Prophylaxis of Invasive Fungal Infections, Pediatric Patients 2 years and older

Benefit-Risk Summary and Assessment

Posaconazole is an azole antifungal agent indicated for the prophylaxis of invasive *Aspergillus* and *Candida* infections in patients who are at high risk of developing these infections due to being severely immunocompromised.

Three Noxafil formulations [Injection (IV), delayed release tablet (DRT) and oral suspension (OS)] are approved for the indication of prophylaxis of IFIs, and for the treatment of oropharyngeal candidiasis, de novo and recurrent, in the case of OS. OS and DRT formulations are approved for use in adults and pediatric patients 13 years of age and older, and the IV is approved in adults only. Based upon the results of pediatric study MK-5992-097 (hereafter referred to as P097), the Applicant sought to expand the indication of prophylaxis of IFIs to include pediatric patients age 2 to 17 years of age for Noxafil Injection and provide oral dosing recommendations with a new age-appropriate formulation, Noxafil for delayed release oral suspension (POWDERMIX), for pediatric patients who weigh 40 kg or less. The new POWDERMIX formulation was developed as a more tolerable, weight-based dosing alternative to the oral tablet with improved and more reliable bioavailability compared to the OS that failed to meet target systemic exposures in a previous phase 1b P032/P03579 pediatric study.

Study P097, a multicenter, open-label, non-comparative, sequential dose-escalation study, evaluated the safety, tolerability, and pharmacokinetics (PK) of three dose regimens of Noxafil IV and Noxafil for delayed release suspension (3.5 mg/kg, 4.5 mg/kg, and 6 mg/kg) in 115 immunocompromised pediatric patients 2 to 17 years of age with neutropenia or expected neutropenia. Efficacy assessments were not performed in this study. All 115 subjects initially received Noxafil injection for at least 7 days, and 63 subjects were transitioned to Noxafil POWDERMIX. The mean overall treatment duration (both formulations) for all treated subjects was 20.6 days with 14.3 days (range: 1 to 28 days) on injection treatment and 11.6 days (range: 2 to 18 days) on Noxafil POWDERMIX.

The safety and effectiveness of Noxafil have been established in pediatric patients 2 to 17 years of age for the prophylaxis of invasive *Aspergillus* and *Candida* infections who are at high risk of developing these infections due to being severely immunocompromised, (e.g. HSCT recipients with GVHD or those with hematologic malignancies with prolonged neutropenia from chemotherapy). Use of Noxafil in these age groups is supported by evidence from adequate and well-controlled studies of Noxafil in adult and pediatric patients 13 years and older and additional PK and safety data in pediatric patients 2 years of age and older. PK-based extrapolation used previously established Cavg target exposure range of 700-2500 ng/ml.

Safety profile of Noxafil IV and POWDERMIX dosed at 6 mg/kg daily is comparable to that of adults with no new safety concerns or dose- (exposure-) or age-related adverse reactions identified. Reported adverse reaction profile of Noxafil in pediatric patients was generally consistent with the safety profile of Noxafil in adults. The most common adverse reactions (occurring in greater than 20% of pediatric subjects receiving Noxafil 6 mg/kg daily dose) were fever, mucositis, pruritus, rash, vomiting, abdominal pain, hypokalemia, and hypertension.

Noxafil POWDERMIX contains sorbitol and the labeling includes a contraindication in patients with hereditary fructose intolerance (HFI) and a Warning regarding the risk of metabolic crisis with use of Noxafil for delayed release suspension in patients in whom HFI has not been diagnosed.

Dimension	Evidence and Uncertainties	Conclusions and Reasons
Analysis of Condition	<ul style="list-style-type: none"> • IFIs are a major cause of morbidity and mortality in immunocompromised pediatric patients, particularly those deemed high risk (with neutropenia or T-cell dysfunction). • Incidence of IFIs ranges from <5% to 10% depending on various factors. • Mortality is as high as 20% in pediatric patients who go on to develop IFI in spite of available prophylaxis and treatment options. 	<ul style="list-style-type: none"> • Significant morbidity and mortality of IFI in high risk immunocompromised pediatric patients and limited armamentarium of approved antifungal agents for IFI prophylaxis in at risk pediatric patients demonstrate the need for additional antifungal agents for prophylaxis in this population.
Current Treatment Options	<ul style="list-style-type: none"> • Currently antifungals used (approved and off-label) for prophylaxis of IFIs in high risk patients include triazoles (fluconazole, itraconazole, posaconazole, and voriconazole), lipid amphotericin B, and echinocandins (caspofungin and micafungin). 	<ul style="list-style-type: none"> • Posaconazole could improve armamentarium of approved antifungal agents for the prophylaxis of IFIs in high risk pediatric patients 2-<18 years.
Benefit	<ul style="list-style-type: none"> • The safety and effectiveness of posaconazole have been established in pediatric patients age 2 to less than 18 years of age for the prophylaxis of invasive <i>Aspergillus</i> and <i>Candida</i> infections who are at high risk of developing these infections due to being severely immunocompromised. 	<ul style="list-style-type: none"> • The safety and effectiveness of posaconazole have been established in pediatric patients age 2 to less than 18 years of age for the prophylaxis of invasive <i>Aspergillus</i> and <i>Candida</i> infections who are at high risk of developing these infections due to being severely immunocompromised.

Dimension	Evidence and Uncertainties	Conclusions and Reasons
	<ul style="list-style-type: none"> Use of posaconazole in pediatric patients 2 years of age and older is supported by evidence from adequate and well-controlled studies of posaconazole in adult and pediatric patients 13 years and older and additional PK and safety data in pediatric patients 2 years of age and older. 	<ul style="list-style-type: none"> The benefit of POS for prophylaxis of IFI in immunocompromised pediatric patients 2 years of age and older outweighs the risks of adverse reactions.
Risk and Risk Management	<ul style="list-style-type: none"> Safety profile of Noxafil Injection and for delayed release oral suspension in pediatric patients 2 years of age and older is comparable to that of adults with no new safety concerns or significant dose- (exposure-) or age-related adverse events identified. Common adverse reactions with the 6mg/kg proposed dose for marketing occurring in greater than 20% of pediatric subjects were fever, mucositis, pruritis, vomiting, abdominal pain, and hypertension. The new age-appropriate pediatric formulation (Noxafil for delayed release oral suspension) contains sorbitol and is contraindicated in patients with hereditary fructose intolerance (HFI). 	<ul style="list-style-type: none"> Reported adverse reaction profile of Noxafil in pediatric patients is similar to that of adults with many of adverse reactions known to be associated with the triazole class of antifungal drugs. Additional class-related concerns are mentioned in the Noxafil USPI. Adverse reactions can be mitigated by routine clinical and laboratory monitoring and review of concomitant medications that may interact with POS. Healthcare providers should inquire about patient's fructose/sucrose tolerance prior to prescribing Noxafil POWDERMIX.

1.3.2. Invasive Aspergillosis, Adults and Pediatric Patients 13 years and older

Benefit-Risk Summary and Assessment

Patients with severe immunocompromise, such as patients with hematologic malignancies with prolonged neutropenia, or HSCT recipients with or without GVHD are at risk of life-threatening IFIs with *Aspergillus* or other invasive molds and yeasts. The evidence to support the efficacy of posaconazole for the treatment of invasive aspergillosis (IA) is from one phase 3 trial MK-5592-069 (Study P069). P069 was a randomized,

controlled, double-blind study of posaconazole IV/oral tablet (POS) versus voriconazole IV/ oral tablet (VOR) in subjects >13 years of age with proven, probable, or possible IA. Subjects were randomized to either POS (N=288) or VOR (N=287) for a planned treatment duration of 12 weeks. The trial was conducted at 91 sites in 26 countries.

The efficacy data from Study P069 demonstrated that treatment with POS was noninferior to VOR with respect to the primary endpoint of all-cause mortality through Day 42. The all-cause mortality rate through Day 42 in the ITT population was 15.3% in the POS group and 20.6% in the VOR group, with a 95% confidence interval (CI) about the treatment difference of [-5.3 (-11.6, 1.0)]; the upper bound of the 95% confidence interval was lower than the prespecified and justified 10% non-inferiority margin. Consistent results were observed for secondary endpoints such as all-cause mortality at Day 42 in the subgroup of patients with proven or probable invasive aspergillosis per EORTC criteria, i.e. (POS, 19.0% vs. VOR, 18.7%) with a 95% CI [0.3 (-8.2, 8.8)]. The global clinical response at Week 6 in this subgroup, as assessed by independent adjudicators, was similar between treatment groups (POS, 44.8% vs. VOR, 45.6%) with a 95% CI [-0.6 (-11.2, 10.1)].

The safety population included 575 patients; 288 in the POS group and 287 in the VOR group. The proportion of all known patient deaths was lower in POS-treated patients (POS, 31.9% vs. VOR, 33.4%). More patients in the POS-treated group experienced serious adverse events, (POS, 62% vs. VOR, 60%). The incidence of treatment emergent adverse events (TEAEs) was identical (97.6%) in the POS and VOR treatment groups; however, fewer patients discontinued POS due to an adverse event, (POS, 32.3% vs. VOR, 35.5%). The proportions of patients with TEAEs that were fatal, recovered, recovering, or not recovered were comparable between the POS and VOR treatment groups. The incidence of TEAEs in gastrointestinal disorders were similar between the two treatment groups. The incidence rates of TEAEs related to skin, eye, and psychiatric disorders were lower in POS-treated patients than for the VOR-treated patients. A higher proportion of patients treated with POS experienced hepatobiliary disorders and metabolism and nutrition disorders (hypokalemia) as compared to VOR. The greatest difference in the incidence of TEAEs between the two treatment groups was hypokalemia (POS, 28.5% vs. VOR, 17.1%).

Hepatotoxicity is associated with azole antifungal drugs. More POS-treated patients experienced hepatobiliary disorders than VOR-treated patients, (POS, 13.5% vs. VOR, 9.1%); increases in hepatic aminotransferases (POS, 18.4% vs. VOR, 17.4%) was the most frequent adverse event in the hepatobiliary disorders and occurred at similar rates in both treatment groups. There was no evidence of an increase in potential Hy's Law cases for POS compared to VOR with incidence rates of 3.8% and 3.5%, respectively. There were no cases of fatal hepatic injury due to study drugs in the trial. No clinically significant cases of QT prolongation were reported in the trial. POS was generally well tolerated and demonstrated a favorable safety profile comparable with VOR. The safety findings for POS in the IA treatment trial were consistent with the

safety results in phase 3 trials of POS for prophylaxis of invasive fungal infections¹ and with the characteristic safety profile of azole antifungal drugs.^{2,3}

In summary, the data in Study P069 demonstrate substantial evidence of effectiveness of POS for the treatment of invasive aspergillosis and an acceptable safety profile as compared to the standard of care, VOR. The potential benefit of POS for treatment of IA outweighs the risk of adverse reactions in immunocompromised patients. The results of the trial support approval of POS IV injection and delayed-release tablets for the treatment of IA in patients 13 years of age and older.

Dimension	Evidence and Uncertainties	Conclusions and Reasons
Analysis of Condition	<ul style="list-style-type: none"> Invasive aspergillosis (IA) is caused by <i>Aspergillus</i> species. IA primarily involves the lungs but may disseminate to other organs such as skin and brain. IA is a major cause of morbidity and mortality particularly among immunosuppressed patients with hematological malignancies with reported mortality rates of 30% to 40% in treated patients. 	<ul style="list-style-type: none"> Invasive aspergillosis (IA) is a life-threatening infection. Mortality rates are high in immunocompromised patients despite best available antifungal therapy. There is an unmet medical need for effective antifungal therapy for IA.
Current Treatment Options	<ul style="list-style-type: none"> In clinical practice, voriconazole (IV and oral tablet) is the primary treatment option for IA with isavuconazonium sulfate (IV and oral) and liposomal amphotericin B (IV) as alternative options for primary treatment. 	<ul style="list-style-type: none"> Posaconazole (injection and posaconazole delayed-release tablets) could be an additional option to treat IA.

¹ Noxafil®: https://www.accessdata.fda.gov/drugsatfda_docs/label/2020/022003Orig1s026,205053Orig1s010,205596Orig1s010lbl.pdf

² Cronin S, Chandrasekar PH. Safety of triazole antifungal drugs in patients with cancer. *J Antimicrob Chemother.* 2010 Mar;65(3):410-6. doi: 10.1093/jac/dkp464.

³ Kyriakidis I, Tragiannidis A, Munchen S, Groll AH. Clinical hepatotoxicity associated with antifungal agents. *Expert Opin Drug Saf.* 2017 Feb;16(2):149-165. doi: 10.1080/14740338.2017.1270264.

Dimension	Evidence and Uncertainties	Conclusions and Reasons
<p><u>Benefit</u></p>	<ul style="list-style-type: none"> The primary endpoint of all-cause mortality rate through Day 42 in the ITT population was 15.3% in the posaconazole group and 20.6% in the voriconazole group, 95% CI [-5.3 (-11.6, 1.0)]. Posaconazole was non-inferior to the standard of care, voriconazole, with respect to all-cause mortality through Day 42. In the subgroup with proven or probable invasive aspergillosis, the results for secondary endpoints, a) all-cause mortality at Day 42 (POS, 19.0% vs. VOR, 18.7%) with 95% CI [0.3 (-8.2, 8.8)] and b) global clinical response at Week 6 (POS 44.8% vs. VOR 45.6%) with 95% CI [-0.6 (-11.2%, 10.1%)], were similar between posaconazole and voriconazole treatment groups. Posaconazole was generally well-tolerated and demonstrated a favorable safety profile as compared to voriconazole. 	<ul style="list-style-type: none"> The safety and effectiveness of posaconazole injection and posaconazole delayed-release tablets have been established for the treatment of IA in patients 13 years of age and older. The potential benefit of posaconazole for treatment of IA outweighs the risk of adverse reactions in immunocompromised patients.
<p><u>Risk and Risk Management</u></p>	<ul style="list-style-type: none"> Adverse events frequently reported with posaconazole in the IA trial included nausea, vomiting, diarrhea, headache, increased hepatic aminotransferases, increased total bilirubin, serum electrolyte abnormalities e.g., hypokalemia, and skin rash. 	<ul style="list-style-type: none"> Most reported adverse reactions are listed in the Noxafil USPI and are known effects of the azole class of antifungal drugs. Other azole class-related adverse reactions are listed in the Noxafil USPI. Potential adverse reactions associated with posaconazole can be mitigated by routine clinical and laboratory monitoring and management of concomitant medications to minimize potential drug-drug interactions.

1.4. Patient Experience Data

Patient Experience Data Relevant to this Application (check all that apply)

<input type="checkbox"/>	The patient experience data that were submitted as part of the application include:	Section of review where discussed, if applicable
<input type="checkbox"/>	Clinical outcome assessment (COA) data, such as	
<input type="checkbox"/>	Patient reported outcome (PRO)	
<input type="checkbox"/>	Observer reported outcome (ObsRO)	
<input type="checkbox"/>	Clinician reported outcome (ClinRO)	
<input type="checkbox"/>	Performance outcome (PerfO)	
<input type="checkbox"/>	Qualitative studies (e.g., individual patient/caregiver interviews, focus group interviews, expert interviews, Delphi Panel, etc.)	
<input type="checkbox"/>	Patient-focused drug development or other stakeholder meeting summary reports	
<input type="checkbox"/>	Observational survey studies designed to capture patient experience data	
<input type="checkbox"/>	Natural history studies	
<input type="checkbox"/>	Patient preference studies (e.g., submitted studies or scientific publications)	
<input type="checkbox"/>	Other: (Please specify):	
<input type="checkbox"/>	Patient experience data that were not submitted in the application, but were considered in this review:	
<input type="checkbox"/>	Input informed from participation in meetings with patient stakeholders	
<input type="checkbox"/>	Patient-focused drug development or other stakeholder meeting summary reports	
<input type="checkbox"/>	Observational survey studies designed to capture patient experience data	
<input type="checkbox"/>	Other: (Please specify):	
<input checked="" type="checkbox"/>	Patient experience data was not submitted as part of this application.	

2 Therapeutic Context

2.1. Analysis of Condition

2.1.1. Prophylaxis of Invasive Fungal Infections, Pediatric Patients 2 years and older

IFIs are a major cause of morbidity and mortality in immunocompromised patients. Immunocompromised pediatric patients at high risk of developing IFIs particularly include those with current and/or expected T-cell dysfunction and/or severe and/or prolonged neutropenia (e.g. patients with acute leukemias, myelodysplasia, aplastic anemia, advanced non-Hodgkin lymphoma, or those who are post-allogeneic stem cell transplant). Although the exact incidence of pediatric IFIs is unclear (ranging from <5% to 10% depending upon various factors) and in spite of multiple IFI-approved prophylactic and therapeutic agents, mortality is as high as 20% in patients who do go on to develop IFI seemingly warranting the need for improved/additional antifungal agents.

2.1.2. Invasive Aspergillosis, Adults and Pediatric Patients 13 years and older

Aspergillus spp. are filamentous, environmental fungi that cause a wide spectrum of infections in humans. *Aspergillus fumigatus* is the most common species infecting humans, followed by *A. flavus*, *A. niger*, *A. nidulans*, and *A. ustus*.⁴ Human infection arises from inhalation of conidia. Invasive aspergillosis (IA) is a life-threatening, invasive mold infection that is observed in severe or prolonged neutropenia and/or T-cell dysfunction, for example, in patients with hematologic malignancies with or without HSCTs, solid organ transplants, and patients taking high dose and/or long-term corticosteroids. IA is a major cause of morbidity and mortality among immunocompromised patients with mortality rates of 30 to 40% in treated patients.⁵ Data from the Transplant Associated Infection Surveillance Network (TRANSNET) indicates that in high-risk populations, such as neutropenic patients and HSCT recipients, the 12-month incidence of IFIs is 3.4%, with IA causing around half of those infections.⁶ In solid organ transplant (SOT) recipients, the overall 12-month incidence rate for any IFI was 3.1% and the annual incidence of IA was 0.65% and was most common in patients with lung transplants.⁷ Transplant type impacts the risk of invasive aspergillosis, with increased rates of infection seen

⁴ KS Gregg and CA Kauffman. Invasive Aspergillosis: Epidemiology, Clinical Aspects, and Treatment. *Semin Respir Crit Care Med* 2015;36:662–672

⁵ Lewis RE, Cahyame-Zuniga L, Leventakos K, et al. Epidemiology and sites of involvement of invasive fungal infections in patients with haematological malignancies: A 20-year autopsy study. *Mycoses* 2013, 56, 638–645.

⁶ Kontoyiannis, DP, Marr KA, Park, BJ, et al. Prospective surveillance for invasive fungal infections in hematopoietic stem cell transplant recipients, 2001-2006: Overview of the transplant-associated infection surveillance network (TRANSNET) Database. *Clin Infect Dis* 2010; 50, 1091–1100.

⁷ Pappas, PG, Alexander, BD, Andes DR, et al. Invasive fungal infections among organ transplant recipients: Results of the transplant-associated infection surveillance network (TRANSNET). *Clin Infect Dis* 2010; 50, 1101–1111

after mismatched HLA, unrelated donor, and cord blood transplants.^{8,9} Invasive aspergillosis in nonneutropenic patients in ICUs is increasingly recognized, with incidence rates as high as 7%.¹⁰ More recently pulmonary aspergillosis has been reported patients with COVID-19 requiring ICU care.¹¹ IA primarily involves the lungs but may disseminate to other organs such as skin and brain. Signs and symptoms depend on which organs are affected, and may include but are not limited to fever, cough, hemoptysis, dyspnea, chest pain, sinus pain, skin lesions, or neurological symptoms.¹²

2.2. Analysis of Current Treatment Options

2.2.1. Prophylaxis of Invasive Fungal Infections, Pediatric Patients 2 years and older

Although few antifungals are officially licensed for use in pediatric patients (due to limited PK/PD data) as compared to adults, many agents from multiple classes are currently used off label in the management of IFIs in pediatric patients due to the significant burden of disease in high risk patients. Although few antifungals are approved for use in pediatric patients as compared to adults, many agents from multiple classes are currently used off label in the management of IFIs in pediatric patients due to the significant burden of disease in high risk patients. Commonly used antifungals in the management of IFI include triazoles (fluconazole, itraconazole, posaconazole, and voriconazole), lipid amphotericin B, and echinocandins (caspofungin and micafungin). Specific agent of choice is dependent upon risks and benefits of each agent in the setting of each individual circumstance with use often limited by potential risks (e.g. adverse events, drug-interactions, absorption/formulation).

The limited number of currently approved antifungal agents for prophylaxis of IFI in pediatric patients as well as the restrictions of use for those antifungals that are currently approved in pediatric patients, in combination with the significant morbidity and mortality of IFIs in high risk pediatric patients, collectively demonstrate the need for additional antifungal agents for use in high risk pediatric populations.

⁸ Garcia-Vidal C, Upton A, Kirby KA, et al. Epidemiology of invasive mold infections in allogeneic stem cell transplant recipients: biological risk factors for infection according to time after transplantation. *Clin Infect Dis* 2008;47(8): 1041–1050.

⁹ Miyakoshi S, Kusumi E, Matsumura T, et al. Invasive fungal infection following reduced-intensity cord blood transplantation for adult patients with hematologic diseases. *Biol Blood Marrow Transplant* 2007;13(7):771–777

¹⁰ Meersseman W, Vandecasteele SJ, Wilmer A, et al. Invasive aspergillosis in critically ill patients without malignancy. *Am J Respir Crit Care Med* 2004; 170(6):621–625.

¹¹ Koehler P, Bassetti M, Chakrabarti A, et al. Defining and managing COVID-19-associated pulmonary aspergillosis: the 2020 ECMM/ISHAM consensus criteria for research and clinical guidance *Lancet Infect Dis*. 2020 Dec 14 doi: 10.1016/S1473-3099(20)30847-1 [Epub ahead of print]

¹² JD Jenks and M Hoenigl. Treatment of Aspergillosis. *J. Fungi* 2018; 4,98; doi:10.3390/jof4030098

2.2.2. Invasive Aspergillosis, Adults and Pediatric Patients 13 years and older

Table 2-1 Summary of Treatment Armamentarium for Invasive Aspergillosis summarizes the antifungal agents that are currently approved and available in the United States for the treatment of invasive aspergillosis (IA). The Infectious Diseases Society of America (IDSA) 2016 guidelines recommend voriconazole as first-line treatment for IA with isavuconazonium and liposomal amphotericin B as alternative options.¹³ Caspofungin, an echinocandin, is approved for patients with refractory IA. Echinocandins can be effective in salvage therapy (either alone or in combination) for IA, but are *not* recommended for routine use as monotherapy for the primary treatment of IA.

Table 2-1 Summary of Treatment Armamentarium for Invasive Aspergillosis in US

Generic name	Brand name	Dosage form
Approved use		
Liposomal amphotericin B	AmBisome	IV
Amphotericin B deoxycholate	Amphotericin B	IV
Amphotericin B Lipid Complex	Abelcet	IV
Voriconazole	Vfend	IV and oral
Itraconazole	Sporanox	Oral
Isavuconazonium sulfate	Cresemba	IV and oral
Caspofungin*	Cancidas	IV
Off-label use		
Posaconazole [†]	Noxafil	IV and oral
Micafungin	Mycamine	IV
Anidulafungin	Eraxis	IV

*Second line treatment

† Approved for prophylaxis of invasive *Aspergillus* and *Candida* infections

¹³ Patterson TF, Thompson III GR, Denning DW, et al. Practice Guidelines for the Diagnosis and Management of Aspergillosis: 2016 Update by the Infectious Diseases Society of America. Clin Infect Dis. 2016; 63(4): e1–e60. doi: 10.1093/cid/ciw326

3 Regulatory Background

3.1. U.S. Regulatory Actions and Marketing History

Posaconazole (Noxafil) immediate release oral suspension was approved in 2006 for prophylaxis of *Aspergillus* and *Candida* infections in immunocompromised patients and for the treatment of oropharyngeal candidiasis. POS delayed-release tablet and POS for IV injection at a dosage of 300 mg PO BID on Day 1 and 300 mg daily were approved by the FDA in 2013 and 2014, respectively.

3.2. Summary of Presubmission/Submission Regulatory Activity

3.2.1. Prophylaxis of Invasive Fungal Infections, Pediatric Patients 2 years and older

Schering Corporation submitted NDA 22003 on December 21, 2005 for Noxafil (posaconazole) for Oral Suspension. The application was approved on September 15, 2006 for the prophylaxis of invasive *Aspergillosis* and *Candida* infections in patients ≥ 13 years of age who are at high risk of developing these infections due to being severely immunocompromised, such as HSCT recipients with Graft versus Host Disease (GVHD) or those with hematologic malignancies with prolonged neutropenia from chemotherapy. Oral suspension formulation, NDA 22027 by Schering Corporation submitted on December 21, 2005, was also approved for the treatment of oropharyngeal candidiasis, including oropharyngeal candidiasis refractory to itraconazole and/or fluconazole on October 20, 2006.

Merck Sharp & Dohme Corporation (MSD) submitted an NDA 205053 for a new delayed release tablet formulation on January 25, 2013, which was approved on November 25, 2013, and an NDA 205596 for an injection formulation on September 13, 2013, which was approved March 13, 2014, for the same prophylaxis indication as NDA 22003 Noxafil (posaconazole) for Oral Suspension. In the approval letters for the aforementioned applications, the Agency established two PREA postmarketing requirements (PMRs):

- **2090-1/2132-1** Conduct a trial in patients, ages 2 to < 18 years, to evaluate the pharmacokinetics (PK), safety, and tolerability of two new formulations of posaconazole (IV solution and/or new age appropriate oral formulation) in immunocompromised pediatric patients with known or expected neutropenia
- **2090-2/2132-2** Conduct a comparative, double-blind, randomized, multi-center trial, in patients ages 2 to < 18 years, to evaluate the safety, efficacy, and tolerability of posaconazole for the prophylaxis of invasive fungal infections (IFI) in pediatric patients with known or expected neutropenia. The Agency added that PMRs 2090-2/2132-2 were required if the results of the pediatric study did not demonstrate similar exposures to adults

MSD opened IND 125097 for the pediatric studies on April 15, 2015. MSD submitted a meeting request to discuss development plans for the pediatric study on November 14, 2018. On

December 18, 2018 the Agency issued written meeting responses agreeing that the Sponsors proposed dose, duration, and number of subjects in study MK-5592-P097 (A Study of the Safety, Tolerability, and Pharmacokinetics of Intravenous (IV) and Powder for Oral Suspension Formulations of Posaconazole (POS) in Immunocompromised Pediatric Subjects with Neutropenia) and MK-5592-032 (A Phase 1B Study of the Safety, Tolerance, and Pharmacokinetics in Immunocompromised Children with Neutropenia). The Agency asked that information from MK-5592-32 be included in the sNDA.

MSD completed the studies and submitted efficacy supplements to NDA 205596/S-012 (IV), NDA 205053/S-012 (oral tablet) and a new NDA 214770 for the new formulation, Noxafil for delayed-release oral suspension (PowderMix) for review by the Agency in order to fulfill the aforementioned PREA PMRs.

3.2.2. Treatment of Invasive Aspergillosis, Adults and Pediatric Patients 13 years and older

The Applicant (MSD) submitted a meeting request September 19, 2006, to discuss their study plan for the treatment of IA in adults and pediatric patients 13 years of age and older. The Agency agreed to the proposed study plan as documented in the November 09, 2006 teleconference meeting minutes. On August 30, 2012, MSD submitted the draft protocol for MK-5592-069 (P069), a randomized, double-blind, double-dummy, noninferiority, comparative clinical trial, to evaluate the efficacy and safety of posaconazole IV and delayed-release tablets compared to voriconazole for the treatment of IA. The final protocol for this study was submitted on November 30, 2012. MSD submitted a Type-C meeting request on February 26, 2016, seeking concurrence on the proposed changes to the primary and secondary endpoints of study MK-5592-069 (P069), to which the Agency agreed on April 29, 2016.

4 Significant Issues from Other Review Disciplines Pertinent to Clinical Conclusions on Efficacy and Safety

4.1. Office of Scientific Investigations (OSI)

Three study sites (1 US and 2 international) were initially chosen for inspection but the COVID-19 global pandemic significantly limited OSI's ability to conduct on-site Good Clinical Practice (GCP) inspections at international sites. A review by Christian Shenouda, M.D. (Good Clinical Practice Assessment Branch, Division of Clinical Compliance Evaluation) noted that one clinical site in Texas, USA (investigator: Dr. Issam Raad) which was a relatively high enrolling site (n=15) was inspected in support of the IA treatment trial, Study P069. No significant issues were found. The OSI and DAI agreed to further assess the conduct of the study by reviewing all the monitoring reports from two high enrolling international sites [investigators: Dr. Dong Gun Lee (Korea) and Dr. Shariq Hader (Canada)]. Based on the results of the onsite inspection and review of the submitted monitoring reports, the OSI concluded that Study MK-5592-069

appeared to have been conducted adequately, and the data generated by these sites were acceptable in support of the indication, for treatment of IA. No site inspections were deemed necessary for the pediatric study.

4.2. Product Quality

Posaconazole powder for delayed-release oral suspension (POWDERMIX) (b) (4)

The finished drug product is presented as a kit that includes eight (8) sachets of posaconazole POWDERMIX (each containing 300 mg of posaconazole), a suspending vehicle in a bottle, measuring devices (notched tip oral syringes), a syringe adapter cap for the suspending vehicle bottle and ancillary components, such as mixing cups. Prior to administration, posaconazole powder is dispersed in 9 mL of suspending vehicle to obtain a suspension with a final posaconazole concentration of approximately 30 mg/mL.

The chemistry, manufacturing and controls (CMC) information (including environmental assessment) for the new posaconazole formulation has been submitted in NDA 214770 (Module 3). The NDA, as amended, has provided sufficient and adequate CMC information to assure the identity, strength, purity, and quality of the proposed drug product, posaconazole for delayed-release oral suspension. During the NDA review, a development of a new, more suitable dissolution method was recommended by the FDA. This method will be developed via a post-marketing commitment (PMC) study mutually agreed to by the FDA and the Applicant. The manufacturing and testing facilities have been found acceptable and an overall "Approve" recommendation was entered into Panorama by the Office of Pharmaceutical Manufacturing Assessment (OPMA) on April 27, 2021. Therefore, this NDA is recommended for approval by the Office of Pharmaceutical Quality (OPQ).

The following PMC will be included in the action letter:

Develop a new dissolution method using constituted suspension samples for the Quality Control (QC) testing of the proposed drug product. Submit a method validation report and include additional dissolution data for constituted suspension samples from unexpired batches using 65 rpm and 75 rpm to determine an appropriate paddle rotation speed.

Final Report Submission: 08/2021

The above changes in the dissolution method resulting from this PMC study should be submitted to the NDA as a prior-approval supplement before marketing any commercial drug product batches.

For further details refer to the OPQ Review dated May 21, 2021 in DARRTS.

The Agency also reached an agreement with the Applicant on an additional PMC aimed at

developing an appropriate administration method for Noxafil PowderMix (posaconazole) to support dosing in pediatric patients who weigh greater than 40 kg. See Section 4.4 and 14 for details.

4.3. Clinical Microbiology

Mechanism of Action

Posaconazole is a triazole that blocks the synthesis of ergosterol, a key component of the fungal cell membrane, through the inhibition of cytochrome P-450 dependent enzyme, lanosterol 14 α -demethylase responsible for the conversion of lanosterol to ergosterol in the fungal cell membrane. Blockage of ergosterol synthesis results in an accumulation of methylated sterol precursors and a depletion of ergosterol within the cell membrane thus weakening the structure and function of the fungal cell membrane. The action is fungistatic.

Antimicrobial Spectrum of Activity

Posaconazole is active against *Candida spp.* except *Candida krusei*, *Cryptococcus neoformans*, *Trichosporon spp.*, *Aspergillus spp.* and *Zygomycetes*. Against dimorphic fungi (including *Blastomyces*, *Coccidioides spp.* and *Histoplasma*, and *Penicillium*) posaconazole demonstrated comparable in vitro activity to itraconazole. Additionally, posaconazole has shown activity against strains of *Candida spp.*, and *Aspergillus spp.* that have shown resistance to fluconazole, voriconazole and itraconazole.

Non-Clinical studies are covered in other INDs and NDAs to which the current NDAs are cross-referenced.

Efficacy

A total of 2,554 clinical isolates of mold-like microorganisms was identified primarily by MALDI-TOF MS and DNA sequencing of 28S genes. Initial identifications were performed at the local laboratories and confirmations were done at a central reference laboratory. The study indicated that only 140/575 (24%) of the subjects had positive cultures for molds of which 116 were *Aspergillus spp.* Invasive aspergillosis was diagnosed primarily by serological methods. *A. fumigatus* the most common *Aspergillus spp.* isolated was found in 76 subjects, followed by *A. flavus* in 19 subjects, *A. niger* 10 subjects, *A. terreus* 7 subjects and subjects infected with mixed cultures of *Aspergillus spp.* and other molds. Overall, the data were too sparse to determine efficacy by separate *Aspergillus* species. The voriconazole treatment arm identified slightly more *Aspergillus* species by culture than did the posaconazole treatment arm (64 vs 52 species).

Table 4-1 shows the isolates of *Aspergillus spp.* identified in the posaconazole and voriconazole arms.

Table 4-1: Clinical Microbiology Summary, Study 069: *Aspergillus spp.* in the Posaconazole and Voriconazole treatment arms

Fungal Species	Posaconazole n(%)	Voriconazole n(%)	Total n(%)
----------------	----------------------	----------------------	---------------

Number of subjects in population	288	287	575
Number of subjects with reported fungal culture results	62(21.5)	78 (27.2)	140 (24.3)
Subjects with Aspergillus mold only	52 (18.1)	64 (22.3)	116 (20.2)
<i>Aspergillus</i>	9	13	22
<i>Aspergillus flavus</i>	9	13	22
<i>Aspergillus fumigatus</i>	36	35	71
<i>Aspergillus lentulus</i>	1	2	3
<i>Aspergillus nidulans</i>	0	1	1
<i>Aspergillus niger</i>	5	9	14
<i>Aspergillus sydowii</i>	0	1	1
<i>Aspergillus tamaritii</i>	1	0	1
<i>Aspergillus terreus</i>	1	7	8
<i>Aspergillus tubingensis</i>	3	2	5
<i>Aspergillus ustus</i>	1	0	1
<i>Aspergillus versicolor</i>	0	1	1

Table 11-4 posaconazole clinical study report P069MK5592

Susceptibility testing was performed using broth microdilution methodology at (b) (4). No interpretive criteria are recognized for posaconazole at this time. However, the applicant has submitted the following MICs for posaconazole against specific *Aspergillus* species. Table 4-2 lists the MICs for the four most common species isolated in this study.

Table 4-2: Activity of Posaconazole tested against Selected *Aspergillus* species using CLSI broth Microdilution method

<i>Aspergillus</i> species	MIC 50 mcg/mL	MIC90 mcg/mL	Range mcg/mL
<i>A. fumigatus</i>	0.5	0.5	0.12 to 1
<i>A. flavus</i>	0.5	1	0.25 to 1
<i>A. niger</i>	1	1	0.5 to 1
<i>A. terreus</i>	0.5	-	0.5 to 0.5

Table 2.7.3 MK-5592 SUMMARY OF CLINICAL EFFICACY

In addition to identifying *Aspergillus* spp., 16 non-*Aspergillus* molds were also identified. The non-aspergillus molds included *Fusarium solani* spp. complex, *Rhizopus oryzae*, *Mucorales* group, *Scedosporium apiospermum/ Scedosporium boydii*, *Exophiala dermatitidis* and *Purpureocillium lilacinum*.

4.4. Division of Medication Error Prevention (DMEPA)

The DMEPA reviewer, Dr. Cameron Johnson, reviewed the human factor validation (HF) study results and identified use errors, close calls and use difficulties, related to reading the measurements on the syringe, not identifying air in the syringe tip, difficulty in removing air

bubbles. She notes that originally the Applicant noted that HF errors could have resulted in the patient receiving between 10% to 20% reduced dose. The clinical review team determined that potential loss of 20% of the dose could potentially result in underdosing leading to reduced efficacy. The Clinical Pharmacology reviewer proposed a dose banding approach in which a higher dose would be administered to certain patients who would have low exposure to account for the potential for up to 20% underdose. Following discussion with the review team at the April 8, 2021 teleconference, the Applicant submitted revised HF study report and clarified that up to 20% less than the prescribed dose was used as a bracketing estimation; however, the largest error actually observed with the task “check and remove air bubbles” after measuring the 8 mL was 12.5%. An agreement was reached between the Applicant and the Clinical Pharmacology team for the weight band pediatric dosing table for Noxafil PowderMix that maximize the percent of pediatric subjects achieving the target exposure range for efficacy and safety taking into consideration the potential for 12.5% reduced dose due to air bubbles.

While the dosing recommendations have been revised to mitigate the risk of underdose, the DMEPA reviewer recommended additional labeling mitigations to the Instructions for Use booklet (IFU) to emphasize the importance of removing air bubbles and air gaps as well as to better inform users of how to identify and remove air gaps in the syringe. Dr. Johnson determined that no further follow up to recategorize the critical and non-critical tasks is needed at this time and that the residual risk is acceptable without further need for risk mitigation strategies.

The currently marketed Noxafil oral suspension and oral tablet are indicated for ages 13 and older. Because the new formulation of Noxafil for delayed-release oral suspension is indicated for pediatric patients between the ages of 2 years old to less than 18 years old, these three products have an overlap in patient population between the ages of 13 years old to less than 18 years old that may lead to confusion among prescribers related to selecting the appropriate product for a patient in this age group. Furthermore, as the oral suspension and for delayed-release oral suspension are not bioequivalent on a mg to mg basis (40 mg/mL vs. 30 mg/mL once mixed), they are not substitutable. The reviewer identified this as risk for medication errors related to dispensing the correct product.

As recommended by DMEPA reviewers, the Applicant provided revised carton labeling for the currently marketed Noxafil oral suspension to include the statement “Attention: Noxafil Oral Suspension is NOT (b) (4) with Noxafil Delayed-Release Tablets or Noxafil Powder for Delayed-Release Oral Suspension due to differences in the dosing of each formulation.” On April 30, 2021 DMEPA found the name, Noxafil PowderMix, conditionally acceptable as the addition of a modifier as well as the proposed carton labeling statement to alert healthcare providers will help to reduce the risk of confusion between the different formulations.

5 Nonclinical Pharmacology/Toxicology

5.1. Executive Summary

No new repeat dose toxicology studies were submitted with this NDA, but data were included in the NDAs to which the current NDAs are cross referenced. These studies have shown that intravenous posaconazole resulted in increased incidence of brain ventricular enlargement in 2-week old dogs dosed for 6 weeks but not in 10-week old dogs dosed for 3 months or in 31-week old dogs dosed for 3 months.

Study TT#14-1001 is reviewed below because it was received by the agency in a previous submission but was not included in the review of any of the referenced NDAs. No significant differences were noted when the mean ventricular volumes were compared between 10-week old beagle dogs treated intravenously with 10 mg/kg posaconazole for 3 months and vehicle treated control dogs. Ventricle volumes were measured by MRI during dosing weeks 4, 8 and 12. The approved prescribing information for NOXAFIL describes another nonclinical study of intravenous posaconazole in very young dogs (dosed from 2 to 8 weeks of age), which showed an increase in the incidence of brain ventricle enlargement in treated animals compared with concurrent control animals. No difference in the incidence of brain ventricle enlargement between control and treated animals was observed following the subsequent 5-month treatment-free period and there were no neurologic, behavioral or developmental abnormalities in the dogs with this finding. The nonclinical review of NDA 205596 describes a third study of intravenous posaconazole in 31-week-old dogs, dosed for three months at 9 mg/kg/day, which showed no statistically significant difference in ventricular volume compared to control animals. Intravenous posaconazole therefore appears to be associated with an increase in the volume in the lateral ventricles in very young (2-8-week-old) dogs but not older (10-week-old) dogs. The clinical significance of this reversible increase in the incidence of brain ventricle enlargement in 2 to 8-week-old dogs is unknown. Since findings were detected in the 8-week old juvenile dogs (approximately equivalent to a child less than one year old) but not in older dogs 10 to 44 weeks old (approximately equivalent to a 1 to 15-year-old patient), the prescribing information has been updated to include this information.

5.1.1. Other Toxicology Studies

Study title/ number: Three-Month Intravenous Toxicity Study in Post-Weaning Juvenile Dogs with a 9-Week Treatment-Free Period. Study TT #14-1001

Key Study Findings

- No significant differences were observed when the mean ventricular volumes were compared between 10-week old beagle dogs treated intravenously with 10 mg/kg posaconazole for 3 months and vehicle treated control dogs.

Conducting laboratory and location: Safety Assessment and Laboratory Animal Resources (SALAR), Merck Research Laboratories, West Point, Pennsylvania, U.S.A.
 GLP compliance: Yes

Methods

Dose and frequency of dosing: 0 (vehicle), 10 mg/kg posaconazole, once daily for 3 months
 Route of administration: Intravenous
 Formulation/Vehicle: 5% Dextrose for Injection, USP
 Species/Strain: *Canis familiaris*, beagle dog.
 Number/Sex/Group: 9
 Age: 10 weeks old
 Satellite groups: 4 of the 9 animals were retained for a 9-week treatment-free recovery group
 Deviation from study protocol affecting interpretation of results: No

Observations and Results: changes from control

[Do not enter text here. Use the table]

Parameters	Major findings
Mortality	One female dog (#14-0009) in the 10 mg/kg/day group was sacrificed moribund on Day 25. Clinical signs included red discoloration of the skin in the ear and the axillary and abdominal areas, discharge from the eyes and mouth, swelling in the muzzle and mouth, decreased activity, and inappetence. Animals were socially housed, with up to 2 animals in adjoining cages and findings were consistent with hemorrhage related to physical trauma. A role for the posaconazole could not be ruled out.
Clinical Signs	There were no posaconazole-related clinical signs.
Body Weights	There were no posaconazole-related bodyweight changes.
Clinical pathology	There were no scheduled sample collections. Changes observed in the female sacrificed moribund on Day 25 (including reduced red blood cell count, hemoglobin concentration, hematocrit) were consistent with hemorrhage secondary to physical injury, and correlate with the gross pathological changes observed.

MRI-measured ventricle volumes	No differences between the treated and vehicle groups in MRI-measured brain ventricle volumes at baseline or during drug dosing weeks 4, 8, or 12.																
Gross Pathology	No drug-related effects were detected among posaconazole-treated animals. Per SOP, only brains were examined.																
Organ Weights	No drug-related effects were detected among posaconazole-treated animals. Per SOP, only brains were weighed.																
Histopathology Adequate battery: Yes	No drug-related effects were detected among posaconazole-treated animals. Per SOP, only brains were examined.																
Toxicokinetics	<table border="1"> <thead> <tr> <th>Sex</th> <th>AUC_{0-24h} (ng*h/mL)</th> <th>C_{max} (ng/mL)</th> <th>T_{max} (h)</th> </tr> </thead> <tbody> <tr> <td>Female</td> <td>139000</td> <td>8200</td> <td>0.14</td> </tr> <tr> <td>Male</td> <td>138000</td> <td>8220</td> <td>0.22</td> </tr> <tr> <td>All</td> <td>138500</td> <td>8210</td> <td>0.18</td> </tr> </tbody> </table>	Sex	AUC _{0-24h} (ng*h/mL)	C _{max} (ng/mL)	T _{max} (h)	Female	139000	8200	0.14	Male	138000	8220	0.22	All	138500	8210	0.18
Sex	AUC _{0-24h} (ng*h/mL)	C _{max} (ng/mL)	T _{max} (h)														
Female	139000	8200	0.14														
Male	138000	8220	0.22														
All	138500	8210	0.18														

6 Clinical Pharmacology

6.1. Executive Summary

The Office of Clinical Pharmacology Division of Infectious Diseases Pharmacology reviewed the clinical pharmacology information contained in the supplemental NDAs and the NDA submissions. The clinical pharmacology information supports the approval of posaconazole (POS) for prophylaxis of invasive *Aspergillus* and *Candida* infections (invasive fungal infections, IFI) in pediatric patients 2 years of age and older and for treatment of invasive aspergillosis in pediatric patients 13 years of age and older and adults.

POS was previously approved for prophylaxis of IFIs as an oral suspension (OS), intravenous injection (IVI), and delayed-release tablet (DRT) (NDAs 022003, 205053, and 205596, respectively). POS is indicated for adults as all three formulations and for pediatric patients aged 13 to 17 years as the OS and DRT. Although the OS was developed first, the IVI and DRT were developed subsequently to address concerns with the OS, including dose-limiting absorption, variable bioavailability, thrice daily dosing, and the requirement for coadministration with a high fat meal.

Prophylaxis of IFIs

In the current sNDAs, the Applicant proposed to expand the prophylaxis indication to pediatric patients between 2 and 17 years of age using the IVI and a new powder for delayed-release oral suspension (POWDERMIX). POS POWDERMIX was developed to provide an age-appropriate formulation for pediatric patients that also optimizes exposure relative to POS OS. The dose regimens for the POWDERMIX and IVI in pediatric patients were supported by matching exposure to a previously identified pharmacokinetic (PK) target based on PK data collected in a PK and safety study in pediatric patients.

The clinical pharmacology review team focused on the following issues:

- PK target for bridging efficacy for prophylaxis of IFIs to pediatric patients
- Dose regimen for POS POWDERMIX and IVI in pediatric patients
- Preventing underexposure due to inaccurate dosing caused by limitations in the administration method
- Effect of food on POS POWDERMIX PK

Treatment of Invasive Aspergillosis

The Applicant submitted an efficacy supplement for POS IVI and DRT for the treatment of invasive aspergillosis (IA). The clinical pharmacology review team focused on the following issues:

- Exposure-response relationship for efficacy
- Requirement to administer POS DRT with food

6.1.1. Recommendations

Prophylaxis of IFIs

A summary of OCP recommendations and comments on key review issues is presented below in Table 6-1.

Table 6-1. Summary of OCP Recommendations & Comments on Key Review Issues (IFI).

Review Issue	Recommendations and Comments														
Pivotal or supportive evidence of safety and effectiveness for prophylaxis of IFIs in pediatric patients ≥ 2 years of age	The pivotal evidence of safety and effectiveness in pediatric patients is supported by matching exposure in pediatric patients to the exposure found to be effective in adults. The effective exposure was assessed in an exposure-response analysis conducted as part of the review for the initial approval of posaconazole. Study P097 assessed PK and safety of posaconazole in pediatric patients.														
General dosing instructions for prophylaxis of IFIs in pediatric patients ≥ 2 years of age	<p>POWDERMIX: The dose to be administered twice daily (BID) on Day 1 then daily (QD) is shown in the table below.</p> <table border="1" data-bbox="787 846 1182 1129"> <thead> <tr> <th>Weight (kg)</th> <th>Dose (Volume)</th> </tr> </thead> <tbody> <tr> <td>10 to <12</td> <td>90 mg (3 mL)</td> </tr> <tr> <td>12 to <17</td> <td>120 mg (4 mL)</td> </tr> <tr> <td>17 to <21</td> <td>150 mg (5 mL)</td> </tr> <tr> <td>21 to <26</td> <td>180 mg (6 mL)</td> </tr> <tr> <td>26 to <36</td> <td>210 mg (7 mL)</td> </tr> <tr> <td>36 to 40</td> <td>240 mg (8 mL)</td> </tr> </tbody> </table> <p>DRT: 300 mg BID on Day 1, then 300 mg QD in patients >40 kg IVI: 6 mg/kg BID on Day 1, then 6 mg/kg QD</p>	Weight (kg)	Dose (Volume)	10 to <12	90 mg (3 mL)	12 to <17	120 mg (4 mL)	17 to <21	150 mg (5 mL)	21 to <26	180 mg (6 mL)	26 to <36	210 mg (7 mL)	36 to 40	240 mg (8 mL)
Weight (kg)	Dose (Volume)														
10 to <12	90 mg (3 mL)														
12 to <17	120 mg (4 mL)														
17 to <21	150 mg (5 mL)														
21 to <26	180 mg (6 mL)														
26 to <36	210 mg (7 mL)														
36 to 40	240 mg (8 mL)														
Labeling for prophylaxis of IFIs in pediatric patients ≥ 2 years of age	<p>The Applicant's proposed labeling required editing in the following sections:</p> <ul style="list-style-type: none"> • Section 2, Dosage and Administration <ul style="list-style-type: none"> ○ Administration with alcohol recommendation ○ Pediatric dose regimen • Section 7, Drug Interactions <ul style="list-style-type: none"> ○ Administration with alcohol • Section 12.3, Pharmacokinetics <ul style="list-style-type: none"> ○ POWDERMIX PK ○ Specific populations 														

Source: Reviewer assessment

Treatment of IA

A summary of OCP recommendations and comments on key review issues is presented in Table 6-2. Summary of OCP Recommendations & Comments on Key Review Issues (IA)..

Table 6-2. Summary of OCP Recommendations & Comments on Key Review Issues (IA).

Review Issue	Recommendations and Comments
Pivotal or supportive evidence of safety and effectiveness for treatment of IA in adults and pediatric patients ≥ 13 years of age	The pivotal evidence of safety and effectiveness is provided by a Phase 3 Study P069 in adult and pediatric patients ≥ 13 years of age administered posaconazole for the treatment of IA. Supportive evidence of effectiveness is provided by the exposure-response analysis for efficacy evaluated using data from the clinical trial.
General dosing instructions for treatment of IA in adults and pediatric patients ≥ 13 years of age	DRT: 300 mg BID on Day 1, then 300 mg QD in patients IVI: 6 mg/kg twice daily (BID) on Day 1, then 6 mg/kg daily (QD)
Labeling for treatment of IA in adults and pediatric patients ≥ 13 years of age	The Applicant's proposed labeling required editing in the following sections: <ul style="list-style-type: none">• Section 8.10, Specific Populations<ul style="list-style-type: none">○ Weight• Section 12, Clinical Pharmacology<ul style="list-style-type: none">○ Pharmacodynamic information for IA○ DRT PK○ Specific populations

Source: Reviewer assessment

6.2. Clinical Pharmacology Questions

6.2.1. Does the clinical pharmacology program provide supportive evidence of effectiveness?

Prophylaxis of IFIs

POS POWDERMIX and IVI

For POS POWDERMIX and IVI, the finding of efficacy in the prophylaxis of IFIs was provided by bridging exposure of POS POWDERMIX and IVI in pediatric patients to the effective exposure in adults receiving the POS OS. From the original POS NDA submission approved in 2006, the Clinical Pharmacology review team identified an exposure-response relationship for efficacy, which was included in the review and referenced in labeling (See the clinical pharmacology review of NDA 22003 by Dr. Seong Jang for more details). As shown in **Error! Reference source not found.** and Table 6-3. Quartile Analysis of Exposure-Response Relationship for Posaconazole in HSCT Recipients Receiving Immunosuppressive Therapy for GVHD, higher steady-state average concentrations (Cavg) of posaconazole were associated with decreased clinical failure.

Figure 6-1. Posaconazole Exposure-Response Relationships in HSCT Recipients Receiving Immunosuppressive Therapy for GVHD

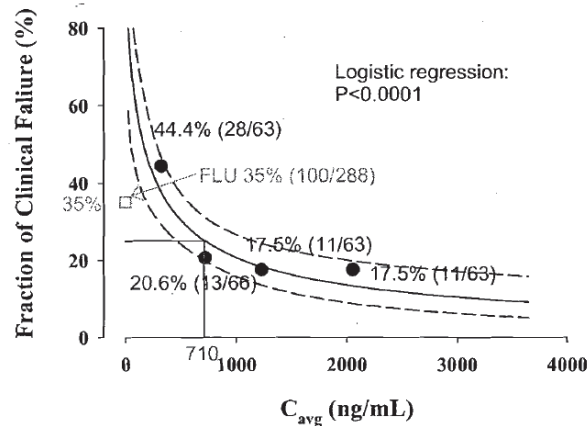

Source: Clinical Pharmacology review for NDA 22003 (2006)

The dashed lines represent 95% Confidence Interval. Subsequent to the logistic regression, the response rates in each of the 4 quartiles of C_{avg} (closed circles) are plotted to assess the goodness-of-fit.

C_{avg} : Steady-state average concentration of posaconazole, FLU: Fluconazole, GVHD: Graft-vs-host disease, HSCT: hematopoietic stem cell transplant

Appears this way on original

Table 6-3. Quartile Analysis of Exposure-Response Relationship for Posaconazole in HSCT Recipients Receiving Immunosuppressive Therapy for GVHD

Quartiles	Q1	Q2	Q3	Q4
C_{avg} (ng/mL)	21.5-557	557-915	915-1563	1563-3650
Clinical Failure	44.4% (28/63)	20.6% (13/63)	17.5% (11/63)	17.5% (11/63)
Proven/probable IFI	4.76% (3/63)	4.76% (3/63)	1.59% (1/63)	3.17% (2/63)

Source: Clinical Pharmacology review for NDA 22003 (2006)

C_{avg} : Steady-state average concentration of posaconazole, GVHD: Graft-vs-host disease, HSCT: hematopoietic stem cell transplant

This identified exposure-response relationship for efficacy was used to generate the PK target for prospective dose regimens of the POS IVI and POWDERMIX in pediatric patients. Originally, the Clinical Pharmacology review team proposed $C_{avg} \geq 700$ ng/mL as the PK target, which was associated with approximately 25% failure rate in HSCT patients receiving immunosuppressive therapy (Study 1). However, the Applicant was concerned that their POS OS, which was the only available formulation at the time, would not be able to achieve POS $C_{avg} \geq 700$ ng/mL in a majority of patients due to its dose-limiting absorption and variable bioavailability (See the clinical pharmacology review of NDA (b) (4) by Dr. Seong Jang for more details). Ultimately, POS $C_{avg} \geq 500$ ng/mL was selected as a more realistic PK target for the OS and to-be-developed formulations. The PK target of POS $C_{avg} \geq 500$ ng/mL was associated with approximately 30% failure rate in Study 1, which was thought to be no worse than the comparator, fluconazole, and thus accepted as the pre-specified PK target prior to initiation of the pediatric clinical trial for safety and PK of POS POWDERMIX and IVI (See Section 15.2.3 for more details). After completion of P097 and assessment of the study results during the current review, the POS POWDERMIX and IVI were shown to have high bioavailability relative to the POS OS, and the

review team revised the PK target back to 700 ng/mL POS Cavg to optimize efficacy in the pediatric patient population.

A different PK target, minimum concentration (C_{min}) ≥ 500 ng/mL, was used as supportive evidence for the proposed indication for the POS DRT and IVI when they were approved in 2013. The Clinical Pharmacology review team at the time determined that Cavg estimates were not appropriate to bridge efficacy from the OS to the DRT and IVI. Only one POS concentration was measured in a majority of patients as a trough concentration, which was not considered to be sufficient for identifying the Cavg in those patients. C_{min} was selected as a conservative estimate of Cavg, given that Cavg will always be higher than C_{min} (See the clinical pharmacology review of NDA 205053 by Dr. Seong Jang for more details). For the present submission, Cavg is the optimal exposure metric because 4-6 samples were collected per patient with each formulation of POS administered, which was deemed sufficient to characterize Cavg in the population PK analysis.

For more details on available clinical pharmacology information to support the proposed dose of POS IVI and POWDERMIX, see the response to Question 2 in Section 6.2.2.

POS DRT

The Applicant's proposed change to the indicated population for POS DRT is supported by clinical pharmacology. POS DRT was approved in pediatric patients 13 years of age and older in a previous supplemental NDA submission. The Applicant proposed to make no changes to the approved dose regimen for POS DRT but to change the indicated population from pediatric patients 13 years of age and older to pediatric patients weighing more than 40 kg. A bodyweight of 40 kg roughly correlates with an age of 13 years as shown in Figure 6-2. Figure 6-2. Relationship Between Age and Weight in Pediatric Patients.. Because age does not affect POS PK within the age range of 2 to 17 years, POS PK in pediatric patients 13 years of age or more is expected to be comparable to POS PK in pediatric patients weighing more than 40 kg. Few pediatric patients 13 years of age and older would be excluded from the category of patients weighing more than 40 kg.

Figure 6-2. Relationship Between Age and Weight in Pediatric Patients.

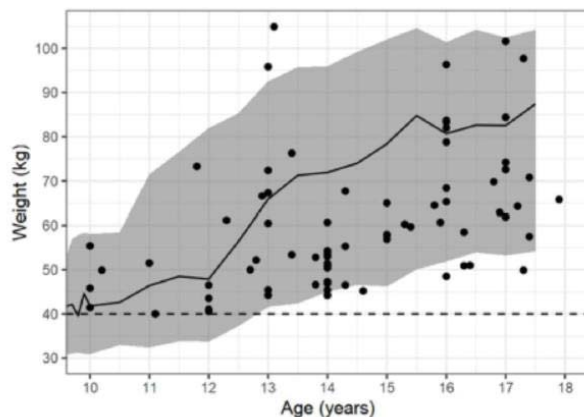

Source: Applicant's response to information request.

The solid black line is the median weight per age and shaded grey area is the 90% interval of weight for each unit of age in the virtual pediatric patient population based on the National Health and Nutrition Examination Survey dataset. Black dots are observed data from pediatric clinical studies.

Overall, the available clinical pharmacology information support changing the indicated population of POS DRT in pediatric patients to those patients weighing more than 40 kg. One concern is that POS DRT may not be suitable for a subset of pediatric patients weighing more than 40 kg who cannot swallow a tablet. Patients weighing more than 40 kg cannot currently be administered the to-be-marketed POS POWDERMIX because the maximum dose that can be administered with the POWDERMIX is 240 mg. To address this concern, the Applicant proposed a PMC study to develop a method to support administering POS POWDERMIX at doses higher than 240 mg to treat patients weighing more than 40 kg (See Section 14 for more details).

Treatment of IA

Efficacy of POS DRT and IVI is primarily supported by a Phase 3 Study P069 in patients with IA (See Section 8.2.1 for more details). Using the collected PK and efficacy data, an exposure-response analysis for efficacy was conducted to evaluate the appropriateness of the proposed dose. For more details, see the response to Question 2 in Section 6.2.2.

6.2.2. Is the proposed dose regimen appropriate for the patient population for which the indication is being sought?

Prophylaxis of IFIs

The Applicant's proposed dose regimen (6 mg/kg BID on Day 1, then 6 mg/kg QD) is appropriate for pediatric patients between 2 and 12 years of age administered POS IVI (b) (4)

(b) (4) The Applicant's proposed dose regimen (300 mg BID on Day 1, then 300 mg QD) is appropriate for pediatric patients >40 kg administered POS DRT. The Clinical Pharmacology review team proposes an alternative POS POWDERMIX dose regimen for prophylaxis of IFI in pediatric patients.

The Applicant conducted P097 to collect PK and safety data and to identify a dose regimen in pediatric patients that would result in 90% of patients with POS Cavg \geq 500 ng/mL. P097 evaluated doses of 3.5, 4.5, and 6 mg/kg POS POWDERMIX and IVI in pediatric patients 2-17 years of age (See Section 15.2.3 for more details). Because the available PK data collected in P097 demonstrated higher bioavailability of POS POWDERMIX and IVI relative to POS OS, the original Cavg PK target of 700 ng/mL was evaluated to optimize efficacy (See Section 6.2 for more details).

Using the Applicant's population PK model, simulations were conducted with (b) (4) dose regimen of 6 mg/kg BID on Day 1 and then QD as shown in Table 6-4. Simulation of (b) (4) Dose Regimen in Pediatric Patients Administered POS POWDERMIX or IV. (hereafter, the numeric dose will be referenced alone while the regimen will stay the same). For POS POWDERMIX, at least 90% of patients achieved the Cavg \geq 700 ng/mL target only in the 30-40 kg weight group but not in patients weighing less than 30 kg. Higher weight groups were

not simulated because the POWDERMIX can only be dosed to a maximum of 240 mg (8 mL). For the POS IVI, at least 90% of patients achieved the Cavg \geq 700 ng/mL target in all weight groups assessed. Thus, the review team agrees with the Applicant's proposed IVI dose (b) (4)

The review team also agrees with the proposed DRT dose, which was supported by the previous approval of POS DRT (See Section 6.2 for more details on the change in indicated population from pediatric patients \geq 13 years of age to pediatric patients >40 kg).

Table 6-4. Simulation of (b) (4) Dose Regimen in Pediatric Patients Administered POS POWDERMIX or IV.

Formulation	Dose (mg/kg)	Weight (kg)	Average Concentration (ng/mL)			
			Geometric Mean	CV%	\geq 500	\geq 700
POWDERMIX	6	10-20	1003	47%	91%	78%
		21-30	1202	47%	96%	87%
		31-40	1382	46%	97%	92%
IVI	6	10-20	1315	39%	100%	95%
		21-30	1571	39%	100%	98%
		31-40	1811	39%	100%	99%
		41-50	1969	38%	100%	100%
		51-60	1953	39%	100%	100%
		61-70	1766	38%	100%	99%
		71-80	1615	39%	100%	99%
		81-90	1468	41%	100%	97%
		91-100	1377	39%	100%	96%

Source: Reviewer's analysis

POWDERMIX: Powder for delayed-release oral suspension, IVI: Intravenous injection, CV: Coefficient of variation
The listed dose represents the dose regimen where the dose is administered twice daily on Day 1 and then once daily. Green highlights were used when the dose regimen achieved the proposed PK target in at least 90% of patients.

Issues with the POWDERMIX formulation, i.e. proposed 300 mg unit dose without overfill, viscosity of the constituted suspension, use of notched-tip syringe for administration, presented additional complications for POWDERMIX dose determination. The Division of Medical Error Prevention and Analysis review team noted the potential for 12.5% loss of drug when 8 mL POS POWDERMIX were administered. This dose loss was caused by issues with the notch-tip design of the syringe, formation of bubbles in the POWDERMIX, and viscosity of the POWDERMIX (See the review for NDA 214770 by Dr. Cameron Johnson for more details). This dose loss was not present when 2.5 mL POS POWDERMIX was administered.

The Clinical Pharmacology review team conducted a simulation with a new POS POWDERMIX dose selected to reach the 700 ng/mL POS Cavg target in approximately 90% of patients or more, to assess the potential for drug loss at higher dose volumes (volume close to 8 mL), and to streamline dosing by weight bands to reduce the potential for medication errors. The review team's updated POS POWDERMIX dose (b) (4) and associated PK target attainment are

shown in Table 6-5. Agency-Proposed POS POWDERMIX Dose and PK Target Attainment.. Approximately 90% or more patients in each weight group had POS Cavg \geq 700 ng/mL, even after the dose was adjusted for 12.5% loss (nominal dose) at higher dose volumes. Although the doses were higher than what was tested in P097 (6 mg/kg), the 90th percentile Cavg in pediatric patients was never more than 10% higher than the safe 90th percentile Cavg identified in pediatric patients treated with 6 mg/kg POS IV, approximately 2500 ng/mL, and lower than the safe 90th percentile Cavg identified in adult patients treated for IA, approximately 3500 ng/mL.

Table 6-5. Agency-Proposed POS POWDERMIX Dose and PK Target Attainment.

Weight (kg)	Nominal Dose (Volume)	Actual Dose (Volume)	Weight-based Actual dose (mg/kg)	Cavg \geq 700 ng/mL	90 th percentile Cavg (Nominal Dose)
10 to <12	90 mg (3 mL)	90 mg (3 mL)	7.5-9	88%	2207
12 to <17	120 mg (4 mL)	120 mg (4 mL)	7.1-10	91%	2475
17 to <21	150 mg (5 mL)	150 mg (5 mL)	7.1-8.8	93%	2607
21 to <26	180 mg (6 mL)	180 mg (6 mL)	6.9-8.6	94%	2716
26 to <36	210 mg (7 mL)	183.75 mg (6.125 mL)	5.1-7.1	90%	2729
36 to 40	240 mg (8 mL)	210 mg (7 mL)	5.3-5.8	90%	2671

Source: Reviewer's analysis

Cavg: average concentration, PK: pharmacokinetics, POWDERMIX: powder for delayed-release oral suspension, POS: posaconazole

The listed dose represents the dose regimen where the dose is administered twice daily on Day 1 and then once daily thereafter. Nominal dose is defined as the dose the healthcare provider or caregiver intends to administer. Actual dose is defined as the minimum expected dose delivered to the patient, accounting for the potential 12.5% dose loss at dose volumes between 7 and 8 mL.

Treatment of IA

Yes, the proposed dose regimen is appropriate for the general patient population, adult and pediatric patients 13 years of age and older. The efficacy and safety of the proposed dose regimen was assessed in P069 in patients with IA. (See Section 8.2.1 for more details)

Additionally, the exposure-response analysis for efficacy for posaconazole in the treatment of IA was flat as shown in Figure 6-3. (See Section 15.2.10 for more details). There was no relationship between posaconazole Cavg (range: 589 to 6315 ng/mL) or Cmin (range: 244 to 5663 ng/mL) and survival, the primary endpoint. Thus, the exposure produced by the Applicant's proposed dose of 6 mg/kg BID on Day 1 then QD DRT or IVI is likely on the plateau of exposure, which indicates that the proposed dose produces maximum antifungal activity of posaconazole in patients with IA.

Figure 6-3. Relationship Between POS Cavg and Survival in IA.

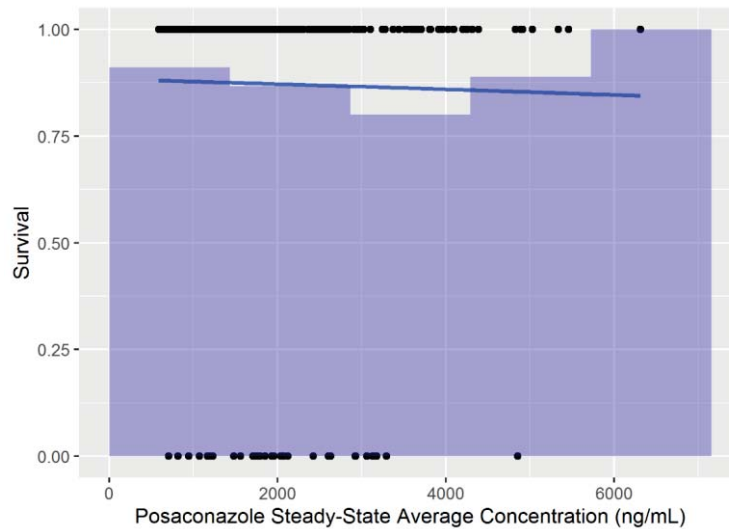

Source: Reviewer's Analysis

POS: Posaconazole, Cavg: steady-state average concentration

The blue shaded area represents the average survival rate for a given interval of posaconazole average concentration.

6.2.3. Is an alternative dose regimen or management strategy required for subpopulations based on intrinsic patient factors?

Prophylaxis of IFIs

The effect of intrinsic factors on POS PK and the need for alternative dose regimens were previously evaluated in NDA reviews for POS. No additional alternative dose regimens are required for the proposed indication in pediatric patients.

Treatment of IA

The effect of intrinsic factors (e.g., weight, sex, hepatic impairment, renal impairment) on POS PK was previously evaluated in the NDA reviews for posaconazole and communicated in labeling. The clinical pharmacology review team focused on the effect of the following additional intrinsic factors on POS PK as it applies to the interpretation of the new data from the current submission (treatment of IA): ethnicity, disease, and age.

Ethnicity

Chinese ethnicity was identified as a significant covariate in the population pharmacokinetic analysis (See Section 15.2.5 for more details), where Chinese patients had 25% lower clearance relative to non-Chinese patients. This lower clearance is not expected to be clinically relevant within the expected range of variability for POS; in Study 69, the 95% interval of POS Cavg was 717-4838 ng/mL. Thus, no dosage adjustment in patients with Chinese ethnicity is needed.

Disease

The effect of disease state was also assessed in the population PK model. Patients with IA had

10% lower clearance relative to healthy subjects and patients treated for prophylaxis of invasive fungal infections. This decreased clearance is not expected to be clinically relevant.

Age – Pediatric Patients

The Clinical Pharmacology review team considered the potential for posaconazole to be indicated for pediatric patients based on matching exposure to what was shown to be effective in adult and adolescent patients.

As shown in Section 6.2.2 (IA), the exposure-response relationship for IA efficacy was flat in the range of tested exposures in Study P069. Thus, efficacy in the treatment of IA could be extrapolated to pediatric patients by matching their exposure to adult patients. Note that the DRT and IVI formulations are not necessarily equally effective. The healthcare providers in P069 had the option to administer the patient POS as a DRT or IVI based on the patient’s condition and clinical judgment. It is likely that more severe cases of IA were treated with the IVI to maximize exposure and to reduce the potential for oral tolerability issues. Thus, POS exposure was considered separately for each formulation, with the summary of exposures from Study P069 shown in Table 6-6. POS Exposure in Study P069 in Adult and Pediatric Patients.

Table 6-6. POS Exposure in Study P069 in Adult and Pediatric Patients ≥ 13 Years Administered POS IVI or DRT Only.

Formulation	Posaconazole Cav _g *	n
IVI	1998 (1085,4635)	32
DRT	1983 (937,3528)	108

*Values reported as median (10th percentile, 90th percentile), Cav_g: Steady-state average concentration
 IVI: Intravenous injection, DRT: Delayed-release tablet, n: sample size
 Source: Reviewer’s Analysis

Simulations of POS Cav_g in pediatric patients administered the proposed dose for prophylaxis of IFI (6 mg/kg BID on day 1, then QD) were compared to those found in adult patients who received POS for IA as shown in Table 6-7. Simulated POS Exposure in Pediatric Patients Relative to PK Target for IA..

Table 6-7. Simulated POS Exposure in Pediatric Patients Relative to PK Target for IA.

Formulation	Weight	POS Cav _g (ng/mL)		
		Geometric Mean	CV	%>PK Target
POWDERMIX	10-20	1003	47%	58%
	21-30	1202	47%	72%
	31-40	1382	46%	80%
IVI	10-20	1311	39%	69%
	21-30	1567	39%	84%
	31-40	1808	39%	92%
	41-50	1965	38%	94%
	51-60	1950	39%	94%
	61-70	1763	38%	90%

Source: Reviewer analysis.

POS: posaconazole, Cav_g: steady-state average concentration, POWDERMIX: Powder for delayed-release oral

suspension, IVI: Intravenous injection, CV: Coefficient of variation

The PK target is the 10th percentile C_{avg} in adults for the oral formulation (937 ng/mL) and intravenous formulation (1085 ng/mL).

The green highlight indicates where the pediatric dose matches adult exposure.

Overall, the POS 6 mg/kg IV dose regimen is sufficient for the treatment of IA in pediatric patients younger than 13 years of age weighing more than 30 kg.

6.2.4. Are there clinically relevant drug-drug or food-drug interactions, and what is the appropriate management strategy?

Prophylaxis of IFIs

There are clinically relevant food-drug and drug-drug interactions for POS POWDERMIX.

Food-Drug Interaction

The Applicant conducted P106 to evaluate the effect of food on the PK of POS POWDERMIX (See Section 15.2.1 for more details), but they used a prototype formulation instead of the final, to-be-marketed (TBM) POS POWDERMIX. The prototype POWDERMIX (pPOWDERMIX) and TBM POWDERMIX both use the same powder, but water was used as a diluent for the pPOWDERMIX instead of the proprietary diluent to be used with the TBM POWDERMIX. As shown in Table 6-8. Effect of Food on POS , administration of food decreased POS C_{max} by 33% and AUC₀₋₇₂ by 6% when given with the pPOWDERMIX. Because C_{avg} (proportional to AUC) is the relevant exposure metric for efficacy in IFI prophylaxis, food was determined not to have a clinically significant effect on POS pPOWDERMIX PK. However, this result could not be bridged to POS TBM POWDERMIX. The difference in diluent could significantly affect solubility of POS and the stability of the suspension, which could both affect the potential for food to affect POS POWDERMIX PK.

Table 6-8. Effect of Food on POS pPOWDERMIX PK.

Treatment	GM (95% CI)		
	C _{max} * (ng/mL)	AUC ₀₋₇₂ * (hr·ng/mL)	T _{max} ** (hr)
pPOWDERMIX Fasted	371 (312, 441)	9957 (8160, 12149)	4.00 (3.00, 12.00)
pPOWDERMIX Fed	251 (211, 298)	9367 (7677, 11431)	8.00 (6.00, 24.00)
Comparison	GMR [90% CI]		
	C _{max} (ng/mL)	AUC ₀₋₇₂ (hr·ng/mL)	
Fed pPOWDERMIX vs Fasted pPOWDERMIX	0.67 [0.59, 0.77]	0.94 [0.87, 1.02]	

Source: Adapted from the Applicant's Clinical Study Report

*: Back-transformed least squares mean and confidence interval from mixed effects model performed on natural log-transformed values.

**: Median (Minimum, Maximum).

Abbreviations: AUC₀₋₇₂, area under the plasma concentration-time curve from 0 to 72 hours; CI, Confidence interval; C_{max}, maximum observed plasma concentration; GM, Geometric least-squares mean; GMR = Geometric least-squares mean ratio between treatments; pPOWDERMIX, prototype powder for delayed-release oral suspension

The effect of food on POS POWDERMIX PK was further assessed in the population PK analysis (See Section 15.2.9 for more details). In the Applicant's final population PK model, food was not

included because it was not statistically significant at the $p < 0.01$ level in the backwards selection process. However, in the Reviewer's analysis, food was a statistically significant covariate on bioavailability at a higher significance level ($p = 0.045$). Additionally, in a bootstrap analysis an effect food on POS POWDERMIX PK could not be ruled out. When food was included in the population PK model, POS bioavailability increased by 20% when POS POWDERMIX was coadministered with food.

Considering all the available data, there are insufficient data to confirm whether food significantly affects POS POWDERMIX PK. To optimize POS exposure with administration of the POWDERMIX and preserve efficacy, the Clinical Pharmacology Review team recommends administration of the POS POWDERMIX with food.

Drug-Drug Interaction

Drug-drug interactions (DDI) for POS have been extensively characterized in previous NDA submissions for POS OS, IVI, and DRT. No differences are expected in the presence or magnitude of systemic DDIs for POS POWDERMIX relative to the previously approved POS formulations. However, there are differences in the presence of local DDIs between formulations. For instance, acid suppressors reduce the bioavailability of POS OS but not POS DRT such that the Noxafil labeling states to avoid use of acid suppressors with POS OS but not with POS DRT.

Gastric Acid Suppressors and Gastrointestinal Motility Agents

The Applicant proposed that gastric acid suppressors and gastrointestinal motility agents will not affect POS POWDERMIX PK. The Clinical Pharmacology review team previously assessed that gastric acid suppressors and motility agents do not affect POS DRT PK based on results from Study 07764 (See the clinical pharmacology review of NDA 205053 by Dr. Seong Jang for more details). (b) (4)

 (For more details on the formulations and release characteristics, see biopharm and chemistry sections). Additionally, 30 of 49 pediatric patients enrolled in the 6 mg/kg cohort of Study P097 were administered at least one acid-reducing agent. Any change in POS PK due to an acid-reducing agent is expected to be accounted for in the population PK model as variability.

Taken together, the review team agrees that POS POWDERMIX would be expected to perform similarly to changes in pH due to gastric acid suppressors and gastrointestinal motility agents as POS DRT and that there is no expected DDI.

Alcohol

The biopharmaceutics reviewer assessed that POS POWDERMIX undergoes dose dumping in the presence of alcohol, particularly at concentrations of 20% and 40% in an in vitro study. Due to the potential for dose-dumping, the POS POWDERMIX may lose its delayed-release

characteristics in the presence of alcohol. In the worst-case scenario, POS POWDERMIX in the presence of alcohol may become more similar to POS immediate-release OS, which has lower and more variable bioavailability. Thus, coadministration of alcohol and POS POWDERMIX could compromise efficacy, and coadministration of alcohol and POS POWDERMIX is not recommended.

Treatment of IA

Food was previously determined to increase the exposure of POS DRT. In a dedicated food-effect study, a high-fat meal increased AUC_{0-72} by 51% and C_{max} by 16%. This increase in POS exposure was described in Noxafil labeling and used to support the recommendation to administer the POS DRT with food for the prophylaxis of IFI. In the Applicant's population PK model, food (irrespective of fat content) increased average concentration by approximately 20%.

Although administration of POS DRT with food will increase exposure of POS, food is not expected to increase antifungal activity in the treatment of IA. The proposed POS dose produced concentrations on the plateau of the exposure-response curve for efficacy (See Section 6.2.2 and 15.2.10 for more details), regardless of administration with food. Food was not a significant covariate in the exposure-response relationship for efficacy. Taken together, food is not expected to improve efficacy when administered with POS DRT.

Additionally, fed administration of POS DRT is not necessary for prophylaxis of IFI. The Applicant previously proposed that the POS DRT could be administered without regards to meals for prophylaxis of IFI. However, insufficient data were collected on food administration status in the registrational prophylaxis trial, and the previous Clinical Pharmacology review team for the NDA supplement approved in 2013 determined that fasted administration of POS DRT in patients for prophylaxis of IFI was not sufficiently assessed. In the present IA trial, food administration was assessed for patients. The 10th percentile of POS C_{avg} in patients administered only the DRT in the fasted state was 867 ng/mL. This is significantly higher than the PK target for prophylaxis of IFI, 700 ng/mL POS C_{avg} . Given that disease had a small effect on POS PK (See Section 6.2.3 for more details), greater than 90% of patients administered POS DRT in a fasted state for prophylaxis of IFI would be expected to have concentration above the PK target for efficacy.

Overall, the available PK data support administration of the POS DRT without regards to meals for both treatment of IA and prophylaxis of IFI.

7 Sources of Clinical Data and Review Strategy

7.1. Table of Clinical Studies

Table 7-1 Study MK-5592-097

Trial Identity	Trial Design	Regimen/ schedule/ route	Study Endpoints	Treatment Duration/ Follow Up	No. of patients enrolled	Study Population
<i>Uncontrolled Studies to Support Efficacy and Safety</i>						
MK-5592-097 NCT02452034 24 centers (11 countries)	Multicenter, uncontrolled, nonrandomized, phase 1B, open-label, PK and safety study in three ascending weight-based dose cohorts in two pediatric age groups of IV and POWDERMIX posaconazole for prophylaxis of invasive fungal infections (IFI) <i>Note: It was initiated in Sep. 2015 and completed (i.e., last subject/ last visit) in Sep.2018.</i>	Posaconazole sequential weight-based dosing cohorts of 3.5, 4.5, and 6mg/kg IV for a minimum of 10 days administered BID on day 1 as a loading dose followed by once daily on days 2-10 (and beyond) who were then switched to POS POWDERMIX for a minimum of 10 days if still neutropenic. <i>Note: If subjects unable to tolerate/refused oral medication they were given the option of remaining on POS IV beyond 10 days with permittance to oral transition any time through day 18 and/or completion of study. POWDERMIX may have been continued beyond ten days if</i>	Primary: Evaluation of PK of IV and POWDERMIX POS Secondary: Evaluation of safety of IV and POWDERMIX POS and tolerability of POWDERMIX POS: adverse events, hematology and blood chemistry, vital signs, and ECG; palatability and acceptability assessment questionnaires <i>Note: This was a phase 1 PK and safety study thus no formal efficacy analysis was done.</i>	At least 10 days POS IV to PO at investigator's discretion up to day 18 Max total duration of POS IV +/- POWDERMIX was 28 days. Safety follow up at 14 days after EOT and survival assessment between days 90-110	118 enrolled 115 of 118 received posaconazole Age Group 1 (2 to <7) 16, 15, and 20 in dose cohorts 1, 2, and 3 Age Group 2 (7 to 17): 21, 17, 29 in dose cohorts 1, 2, 3 Cohort 1 (3.5mg/kg) Age 2 to <7: 14 (87.5%) treated (14 IV, 6 POWDERMIX) Age 7-17: 21 (100%) treated (21 IV, 11 POWDERMIX) Cohort 2 (4.5mg/kg) Age 2 to <7: 15 (100%) treated (15 IV, 9 POWDERMIX) Age 7-17: 16 (94.1%) treated (16 IV, 9	Immunocompromised pediatric patients 2 to 17y in two cohorts with actual or anticipated neutropenia (ANC <500/mm ³) expected to last for at least 7 days in setting of specified conditions:

Trial Identity	Trial Design	Regimen/ schedule/ route	Study Endpoints	Treatment Duration/ Follow Up	No. of patients enrolled	Study Population
		<p><i>subject remained neutropenic. Max of 300mg per administered dose and max duration of POS IV +/- POWDERMIX was 28 days.</i></p>			<p>POWDERMIX), Cohort 3 (6mg/kg - dose proposed for marketing) Age 2 to <7: 20 (100%) treated (20 IV, 14 POWDERMIX) Age 7-17: 29 (100%) were treated (29 IV, 14 POWDERMIX)</p>	
<i>Other studies pertinent to the review of efficacy or safety</i>						
p03579/p032	<p>Phase 1B, nonrandomized, multicenter open-label, sequential dose-escalation PK, safety, and tolerability study of oral suspension (OS) POS in immunocompromised pediatric subjects with neutropenia</p> <p><i>Note: OS form is currently approved for adult and adolescent use. This study was terminated early (Jul10 2015) due to failure of POS OS formulation to meet PK exposure target (90% of subjects with Cavg 500 to <2500ng/mL) at any</i></p>	<p>12mg/kg/day divided BID, 18mg/kg/day divided TID, and 12mg/kg/day divided TID</p>	<p>Primary: A study of the safety, tolerability, and PK of OS POS in immunocompromised pediatric subjects with neutropenia</p>	<p>Treatment duration: up to 28 days</p>	<p>142 enrolled 1 subject 1 to <2 141 subjects 2 to <18</p>	<p>Immunocompromised pediatric subjects with neutropenia in patients aged 2 to <18</p>

Trial Identity	Trial Design	Regimen/ schedule/ route	Study Endpoints	Treatment Duration/ Follow Up	No. of patients enrolled	Study Population
	<i>studied dose</i>					

Source: Table constructed by clinical reviewer.

Table 7-2 Study MK-5592-069

Trial Identity	Trials Design	Regimen	Endpoints	Treatment Duration	No. of Patients	Study Population
MK-5592-069 NCT 01782131 91 centers (26 countries)	Randomized, controlled, double-blind, double-dummy, parallel-group, trial Indication: Treatment of invasive aspergillosis	POS (IV or PO): 300mg BID on Day 1 and once daily VOR: 4mg IV BID (6mg/kg IV BID on Day 1) or 200mg PO BID (300mg BID on Day 1) <i>Note: Transition from IV to oral drug when patient stable</i>	Primary: All-cause mortality through Day 42 in ITT Key secondary: All-cause mortality through Day 42 in FAS population; Global clinical response at Week 6 and Week 12 in FAS population	12 weeks	N=585 POS: 293 randomized/ 288 treated VOR: 292 randomized/ 287 treated	344 males 231 females Age Group: 14 to 91y; Median: 57y; Age < 18y: 5 patients; Age ≥ 65y: 160 patients

Source: Table constructed by clinical reviewer.

POS: posaconazole; VOR: voriconazole, BID: twice daily; Y: years; ITT: Intention to treat population, i.e, all randomized subjects who received at least one dose of study drug;

FAS: All randomized subjects classified as having proven or probable IA by EORTC criteria and adjudicated by independent Clinical Adjudication Committee (see Table 8-1).

7.2. Review Strategy

The indication for treatment of IA is supported by Study MK-5592-069 (P069), a randomized, double-blind, double-dummy, noninferiority, comparative clinical trial, which evaluated the efficacy and safety of POS IV and delayed-release tablets compared to VOR for the treatment of IA. Study MK-5592-069 randomized 585 patients (>13 years of age) with IA. The clinical trial design and review strategy are presented in sections 8.1 and 10.1.

The indication for prophylaxis of *Candida* and *Aspergillus* infections in pediatric patients is supported by Study MK-5592-097 (Study P097), a pharmacokinetic, safety and tolerability study of IV posaconazole and posaconazole POWDERMIX for prophylaxis of IFIs in immunocompromised pediatric patients 2 to < 18 years of age. The clinical trial design and review strategy are presented in section 11.2.

8 Statistical and Clinical Evaluation

8.1. Assessment of Efficacy for the Prophylaxis of IFIs in Pediatric Patients 2 years of Age and Older

Study MK-5592-097 (study P097) a single nonrandomized, multicenter, open-label, sequential dose-escalation study that evaluated 3 dose regimens of POS IV and POS POWDERMIX in immunocompromised children and adolescents aged 2 to 17 years with neutropenia or expected neutropenia (ANC <500/mm³). Formal efficacy assessment was not performed.

Efficacy for the prophylaxis of IFIs in pediatric patients 2 years of age and older was extrapolated from adequate and well controlled prophylaxis trials in adults and pediatric patients 13 years of age and older (study P01899 and P00041) based upon matching established PK exposure target (~90% of subjects achieving C_{avg} range of 500 ng/mL to <2500ng/mL; C_{avg} of 1200 ng/mL). Pediatric exposure targets were determined by exposure-response analysis of the PK data from adult trials of POS OS. Upon further review, it was determined that C_{avg} minimum of ≥700 ng/mL is a more appropriate exposure target. For detailed analyses of the PK data from Study P097 refer to Section 6.

8.2. Review of Relevant Individual Trials Used to Support Efficacy in Invasive Aspergillosis

8.2.1. Study P069

Trial Design

Study P069 was a randomized, double-blind, active controlled, multicenter study designed to assess the efficacy and safety of POS versus VOR in the treatment of IA in adults and adolescents. This was a multinational study conducted in 26 countries in the Asia/Pacific region, Europe, and North and South America at 91 study sites.

Eligible subjects included males and females aged ≥ 13 years with a diagnosis of proven, probable, or possible IA as defined by the 2008 EORTC/MSG disease definitions at the time of randomization. Subjects with possible IA were to be in the process of an ongoing diagnostic work up which was anticipated to result in a mycological diagnosis of proven or probable IA post-randomization. Each subject was to have a central line in place or planned to be in place prior to the beginning of IV study therapy. Subjects without central catheter access were to be clinically stable and able to receive oral therapy. Subjects were not eligible if they had chronic IA, relapsed/recurrent IA, or refractory IA which had not responded to prior antifungal therapy; had pulmonary sarcoidosis, aspergilloma, or allergic bronchopulmonary aspergillosis; had a known mixed invasive mold fungal infection including *Zygomycetes*, and/or a known invasive *Aspergillus* fungal infection in which either study drug may not be considered active; or received any systemic

Version date: October 12, 2018

NDA Multi-disciplinary Review and Evaluation, sNDA 205596, 205053, 214770

NOXAFIL® (posaconazole) injection, delayed release tablet, PowderMix

For prophylaxis of invasive fungal infections in pediatric patients 2 years of age and older

For treatment of invasive aspergillosis in adults and pediatric patients 13 years and older

(oral, intravenous, or inhaled) antifungal therapy for 4 or more consecutive days (≥ 96 hours) immediately prior to randomization.

Eligible subjects were randomized in a 1:1 ratio to receive posaconazole or voriconazole. Randomization was stratified by risk status for mortality and poor outcome (high-risk or not high-risk). High-risk criteria included allogeneic HSCT, relapsed leukemia undergoing salvage chemotherapy, or liver transplant recipient.

Both the IV and tablet formulations of posaconazole and voriconazole were used in the study. The tablet formulation of voriconazole was over-encapsulated. The recommended initial route of administration was IV. However, subjects could begin with oral therapy or switch from IV to oral if they were clinically stable and able to tolerate oral dosing.

Subjects randomized to posaconazole received 300 mg IV or oral BID on Day 1 and from Day 2 onwards 300 mg IV or oral QD. Subjects randomized to voriconazole received 6 mg/kg IV or 300 mg oral BID on Day 1 and from Day 2 onward 4 mg/kg IV BID or 200 mg oral BID. To maintain the blinding, subjects randomized to posaconazole received a placebo IV infusion from day 2 onwards as the second daily dose. While on oral therapy, subjects randomized to posaconazole also received dummy capsules matching voriconazole and subjects randomized to voriconazole also received dummy tablets matching posaconazole so that all subjects received the same number of tablets and capsules per day.

The recommended duration of treatment was 12 weeks (84 days) with a maximum allowable duration of up to 98 days. All randomized subjects who received at least one dose of study medication were to complete visits at Week 6 and Week 12, and a final study visit at Week 16. Regardless of whether the subject discontinued study therapy prior to Day 84, they were to be followed for mortality assessment through Day 114.

The dose regimen of posaconazole used in the study was based on prior clinical development of posaconazole including Phase 1B/3 studies conducted in patients given the IV solution or tablet as antifungal prophylaxis. A target concentration of Cavg exposure of at least 1250 ng/mL has been associated with higher response rates in subjects with IA (posaconazole is approved in other regions for the salvage treatment of IA). The loading dose on Day 1 allows for the target concentration to be more rapidly and more consistently achieved. The dose regimen selected for voriconazole is consistent with the current voriconazole prescribing information and recommendations for the treatment of IA made in the most recent guidelines of the Infectious Diseases Society of America (2008).

An independent, blinded Clinical Adjudication Committee (CAC) evaluated each subject's data to determine the baseline classification of the fungal infection, the assessment of global clinical response at Week 6 and Week 12, and an assessment of attributable mortality through Day 42 and Day 84. The CAC classified each subject as having proven, probable, or possible IA, or as unable to determine if co-morbidities or insufficient data precluded classification. Using the 2008
Version date: October 12, 2018

EORTC/MSG guidelines based on clinical signs and symptoms, imaging, serologic testing, and fungal culture and histology, the CAC classified global clinical response as complete, partial, stable, progression of fungal disease, death, or unable to determine if comorbidities or insufficient data precluded evaluation of the response at the pre-specified time points.

Study Endpoints

The primary efficacy endpoint is all-cause mortality at Day 42 in the intent-to-treat (ITT) population. Secondary endpoints include the global clinical response at Week 6 and Week 12 in the full analysis set (FAS) population, all-cause mortality through Day 42 and Day 84 in the FAS population, and all-cause mortality through Day 84 in the ITT population.

Global clinical response at Week 6 and Week 12 were based on the 2008 MSG/EORTC Guidelines (Table 8-1) as adjudicated by the CAC. A successful outcome included complete and partial response. Failure included stable response, progression of fungal disease, and death. For global clinical response, a visit window of ± 2 weeks was used for the Week 6 assessment and ± 4 weeks was used for the Week 12 assessment.

Table 8-1: Global Clinical Response Definitions from the 2008 MSG/EORTC Guidelines

Outcome, Response	Criteria
Success	
Complete Response	Survival within the prespecified period of observation, resolution of all attributable symptoms and signs of disease, resolution of radiological lesion(s), and documented clearance of infected sites that are accessible to repeated sampling.
Partial Response	Survival within the prespecified period of observation, improvement in attributable symptoms and signs of disease, improvement of radiological lesion(s) ^a , and evidence of clearance of infected sites that are accessible to repeated sampling. In the case of radiological stabilization ^b , resolution of all attributable symptoms and signs of fungal disease; or where biopsy of an infected site shows no evidence of hyphae; or where culture is negative
Failure	
Stable Response	Survival within the prespecified period of observation and minor or no improvement in fungal disease; or persistent isolation of <i>Aspergillus</i> spp or histological present in infected sites.
Progression of fungal disease	Worsening of clinical symptoms and signs of disease plus new sites of disease or radiological worsening; or persistent isolation of <i>Aspergillus</i> spp from infected sites.
Death	Death during the prespecified period of evaluation, regardless of attribution.

Source: Table 11 of P069 protocol

^a improvement of radiological lesions is defined as at least 25% reduction in diameter of radiological lesion.

^b radiological stabilization is defined as 0%-25% reduction in the diameter of the lesion.

Statistical Analysis Plan

A separate statistical analysis plan (SAP) was not issued for this study. Therefore, the statistical analysis methods and procedures for the study were finalized under the final version of the protocol (Protocol Amendment #6 dated February 7, 2017) and implemented prior to database

Version date: October 12, 2018

lock. No changes in the planned analyses following study unblinding and/or post-hoc analyses were performed by the Applicant. See section below on Protocol Amendments, for a discussion of protocol changes relative to the statistical methods and the change in the primary endpoint.

Analysis Populations

The ITT population includes all randomized subjects who received at least one dose of study treatment.

The FAS population includes all randomized subjects who are classified as having proven or probable IA as adjudicated by the CAC and received at least one dose of study treatment.

The primary analysis population is the ITT for the analysis of all-cause mortality through Day 42 and the FAS for analyses of global clinical response. Subjects are included in the treatment group to which they are randomized for the analysis of efficacy data using the ITT and FAS populations.

Safety analyses are conducted on the All Patients as Treated (APaT) population. The APaT population includes all randomized subjects who took at least one dose of study treatment. Subjects are included in the treatment group corresponding to the study treatment they actually received for the analysis of safety data using the APaT population.

Analysis Methods

The primary analysis was a comparison of the all-cause mortality rate through Day 42 between posaconazole and voriconazole. The difference in mortality rate between arms (posaconazole-voriconazole) and corresponding 95% confidence interval was calculated using Miettinen and Nurminen's method stratified by risk for mortality/poor outcome. If the upper limit of the confidence interval is less than the 10% non-inferiority margin, then non-inferiority of posaconazole is declared. Refer to Section 8.3 for a discussion on the justification of the 10% non-inferiority margin.

Secondary endpoints were also analyzed by calculating the difference in the rate between treatment arms and the corresponding 95% confidence interval using Miettinen and Nurminen's method stratified by risk for mortality/poor outcome. Formal tests of hypotheses were not planned for the secondary endpoints.

Missing or unable to determine responses were considered failures in all analyses.

Sample Size Calculation

Assuming an all-cause mortality rate of 23% for voriconazole and a 10% non-inferiority margin, a sample size of 300 subjects per arm would have approximately 80% power detect non-inferiority of posaconazole with a one-sided $\alpha = 0.025$.

Interim Analysis

Version date: October 12, 2018

NDA Multi-disciplinary Review and Evaluation, sNDA 205596, 205053, 214770
NOXAFIL® (posaconazole) injection, delayed release tablet, PowderMix
For prophylaxis of invasive fungal infections in pediatric patients 2 years of age and older
For treatment of invasive aspergillosis in adults and pediatric patients 13 years and older

No formal interim analysis of efficacy data was conducted. Routine monitoring of safety data was conducted by an independent external Data Monitoring Committee.

Protocol Amendments

The original protocol was dated November 15, 2012. The study was initiated on October 25, 2013 and was completed on September 10, 2019. There were 5 amendments to the protocol with the first 2 amendments made prior to enrolling any subjects. Most changes to the protocol were for clarification purposes. Changes that impacted aspects of study design included the following:

- Protocol Amendment 3 (January 8, 2015) allowed for the enrollment of adolescent subjects (13 years and older) outside of the European Union.
- Protocol Amendment 4 (August 1, 2016) revised the ordering of the primary and key secondary endpoints. The key secondary endpoint of all-cause mortality at Week 6 became the primary endpoint and the primary endpoint of global response at Week 6 became a key secondary endpoint. The Division agreed to this change to align with regulatory precedent as all-cause mortality is a more objective endpoint and is the endpoint for which a data-driven justification of the non-inferiority margin is available. Analysis methods, sample size calculation, and non-inferiority margin justification were updated to align with the change. Additionally, a 90-day post-therapy follow-up visit (Week 24) was deleted as no analyses were planned for that timepoint.
- Protocol Amendment 5 (February 7, 2019) clarified that mortality was to be evaluated through Day 42 and Day 84 with no time window applied before or after the target date. For global clinical response, visit windows of ± 2 weeks for Week 6 and ± 4 weeks for Week 12 were specified.

The modifications to the protocol do not impact the integrity of the trial.

8.2.2. Study Results

Compliance with Good Clinical Practices

The Applicant states that “This study was conducted in conformance with the ethical principles originating from the Declaration of Helsinki, GCP requirements, and applicable country and/or local statutes and regulations regarding IEC review, informed consent and the protection of human subjects in biomedical research, as stated in the MSD Code of Conduct for Interventional Clinical Trials in the study protocol.”

Data Quality and Integrity

In general, the data submitted by the Applicant were acceptable and there were no issues noted with regard to the data quality and integrity.

Financial Disclosure

Version date: October 12, 2018

See section 15.1

Patient Disposition

A total of 585 subjects were randomized in the study. Ten subjects (5 in each treatment arm) did not receive any study medication and were excluded from all efficacy and safety analyses. All treated subjects received the treatment to which they were randomized. Therefore, the ITT and the APaT populations are the same and include 288 posaconazole subjects and 287 voriconazole subjects. A total of 125 (42.7%) posaconazole subjects and 116 (41.4%) voriconazole subjects were not classified as having proven or probable IA by the adjudicator and were excluded from the FAS. The analysis populations are summarized in Table 8-2: Analysis Populations.

Table 8-2: Analysis Populations

Analysis Population	Posaconazole	Voriconazole	Total
	N (%)	N (%)	N (%)
Randomized	293 (100)	292 (100)	585 (100)
ITT/APaT	288 (98.3)	287 (98.3)	575 (98.3)
FAS	163 (55.6)	171 (58.6)	334 (57.1)

Source: Reviewer conducted analysis using ADSL dataset

Overall, 49% of the subjects in the ITT population completed treatment. In general, most subjects were to receive the recommended 12 weeks of treatment; however, a subject was considered to have completed study treatment if the subject had recovered from IA (physician's opinion) during a maximum of 12 weeks of study treatment. For both treatment arms, the most common reason for premature discontinuation of study treatment was due to an adverse event (23%) followed by physician decision (12%). All subjects were to be followed for the duration of the study (through Day 114) for survival regardless of the duration of study therapy. A total of 63% of the subjects in the ITT population completed the study. The most common reason for premature discontinuation from the study for both treatment arms was due to death of the subject (33%). Subject disposition including the reason for discontinuing treatment and the study are summarized in Table 8-3: Subject Disposition (ITT Population).

Table 8-3: Subject Disposition (ITT Population)

	Posaconazole	Voriconazole	Total
	N (%)	N (%)	N (%)
ITT	288 (100)	287 (100)	575 (100)
Completed Treatment	139 (48.3)	142 (49.5)	281 (48.9)
Discontinued Treatment	149 (51.7)	145 (50.5)	294 (51.1)
Adverse event	67 (23.3)	68 (23.7)	135 (23.5)
Death	26 (9.0)	35 (12.2)	61 (10.6)
Lost to follow-up	1 (0.3)	0	1 (0.2)
Non-compliance with study drug	4 (1.4)	2 (0.7)	6 (1.0)
Physician decision	38 (13.2)	32 (11.1)	70 (12.2)
Protocol deviation	1 (0.3)	0	1 (0.2)
Completed Study	184 (63.9)	177 (61.7)	361 (62.8)
Discontinued Study	104 (36.1)	110 (38.3)	214 (37.2)

Version date: October 12, 2018

Death	93 (32.3)	96 (33.4)	189 (32.9)
Lost to follow-up	1 (0.3)	3 (1.0)	4 (0.7)
Other	0	1 (0.3)	1 (0.2)
Withdrew consent	10 (3.5)	10 (3.5)	20 (3.5)

Source: Table 14.1-1 of P069 Clinical Study Report and confirmed by Reviewer using ADSL dataset

Protocol Violations/Deviations

At least 1 important protocol deviation was reported for 62 (10.8%) subjects (33 posaconazole and 29 voriconazole). The most commonly reported important protocol deviations were in the safety reporting category for the reason that a reportable safety event and/or follow up safety event information was not reported per the timelines outlined in the protocol. No important protocol deviations were classified as a serious GCP compliance issue. The reported protocol deviations are not expected to have had an impact on safety or efficacy analyses and the overall study results.

Table 8-4: Protocol Deviations (ITT Population)

Category	Posaconazole (N=288) n (%)	Voriconazole (N=287) n (%)	Total (N=575) n (%)
At least 1 important protocol deviation	33 (11.5)	29 (10.1)	62 (10.8)
Inclusion/Exclusion Criteria	3 (1.0)	1 (0.3)	4 (0.7)
Informed Consent	1 (0.3)	0	1 (0.2)
Prohibited Medications	10 (3.5)	7 (2.4)	17 (3.0)
Safety Reporting	18 (6.3)	14 (4.9)	32 (5.6)
Study Intervention	6 (2.1)	7 (2.4)	13 (2.3)
Trial Procedures	0	3 (1.0)	3 (0.5)

Source: Adapted from Table 14.1-5 of P069 Clinical Study Report

Demographic and Other Baseline Characteristics

Table 8-5 summarizes demographic and baseline characteristics of subjects in the ITT population. The treatment groups were balanced with respect to the baseline characteristics. The majority of subjects were male (59.8%) and white (67.1%). The median age was 57 years. Approximately 50% of the subjects were from European sites and 33 subjects (< 6%) were from the United States. Almost 40% of the subjects were considered to be high risk for IA mortality or poor outcome.

Table 8-5: Demographic and Baseline Characteristics (ITT Population)

Parameter	Posaconazole (N=288) n (%)	Voriconazole (N=287) n (%)	Total (N=575) n (%)
Sex			
Male	172 (59.7)	172 (59.9)	344 (59.8)
Female	116 (40.3)	115 (40.1)	231 (40.2)
Race			
White	194 (67.4)	192 (66.9)	386 (67.1)

Version date: October 12, 2018

Black	3 (1.0)	4 (1.4)	7 (1.2)
Asian	62 (21.5)	60 (20.9)	122 (21.2)
Other	29 (10.1)	31 (10.8)	60 (10.4)
Ethnicity			
Hispanic	48 (16.7)	57 (19.9)	105 (18.3)
Not Hispanic	220 (76.4)	219 (76.3)	439 (76.3)
Not Reported	16 (5.6)	9 (3.1)	25 (4.3)
Age (years)			
Mean (sd)	53.5 (16.7)	53.0 (15.9)	53.3 (16.3)
Median	56.5	57.0	57.0
Min, Max	14, 85	15, 91	14, 91
<18	3 (1.0)	2 (0.7)	5 (0.9)
18 to 64	200 (69.4)	210 (73.2)	410 (71.3)
≥ 65	85 (29.5)	75 (26.1)	160 (27.8)
Region			
Asia Pacific	61 (21.2)	60 (20.9)	121 (21.0)
Europe	149 (51.7)	147 (51.2)	296 (51.5)
North America	43 (14.9)	39 (13.6)	82 (14.3)
US	21 (7.3)	12 (4.2)	33 (5.7)
Ex-US	22 (7.6)	27 (9.4)	49 (8.5)
South America	35 (12.2)	41 (14.3)	76 (13.2)
Risk Status			
High Risk	113 (39.2)	113 (39.4)	226 (39.3)
Not High Risk	175 (60.8)	174 (60.6)	349 (60.7)

Source: Adapted from Tables 10-5, 14.1-2 of P069 Clinical Study Report and confirmed by Reviewer using ADSL dataset

The independent adjudicators classified 58.1% of subjects in the ITT population as having proven or probable IA. These subjects make up the FAS population. Slightly more posaconazole subjects were classified as having proven IA (9.0%) compared to voriconazole subjects (5.2%), while more voriconazole subjects were classified as having probable IA (54.4%) compared to posaconazole subjects (47.6%). Approximately 44% of the subjects were diagnosed as proven or probable IA based on serology alone for the microbiologic criteria. A positive mold culture was identified for 140 subjects and the majority (116 subjects) had a culture positive for *Aspergillus* only. For those subjects with *Aspergillus* only, the most commonly identified species was *A. fumigatus* (36 posaconazole and 35 voriconazole subjects) followed by *A. flavus* (9 posaconazole and 13 voriconazole subjects). The site of infection was the lung only for 80% of the subjects. With regard to the risk factors for IA, approximately two-thirds of the subjects had a recent history of neutropenia, 21.6 % had received an allogeneic HSCT, and 31.7% had prolonged use of corticosteroids.

Table 8-6 : Characterization of Baseline Diagnosis (ITT Population)

Parameter	Posaconazole	Voriconazole	Total
	(N=288) n (%)	(N=287) n (%)	(N=575) n (%)
Aspergillosis Classification*			
Proven	26 (9.0)	15 (5.2)	41 (7.1)

Version date: October 12, 2018

Probable	137 (47.6)	156 (54.4)	293 (51.0)
Possible	81 (28.1)	79 (27.5)	160 (27.8)
Cannot be determined	44 (15.3)	37 (12.9)	81 (14.1)
Methodology for Classification*			
Serology only	129 (44.8)	124 (43.2)	253 (44.0)
Serology + Culture/Microscopy/Histopathology	63 (21.9)	74 (25.8)	137 (23.8)
Culture/Microscopy/Histopathology only	25 (8.7)	21 (7.3)	46 (8.0)
Missing	71 (24.7)	68 (23.7)	139 (24.2)
Fungal Culture Positive			
Aspergillus mold only	52 (18.1)	64 (22.3)	116 (20.2)
Non-Aspergillus mold only	7 (2.4)	10 (3.5)	17 (3.0)
Aspergillus mold and non-Aspergillus mold	3 (1.0)	4 (1.4)	7 (1.2)
Site of Infection*			
Lung	230 (79.9)	230 (80.1)	460 (80.0)
Multiple Sites	48 (16.7)	45 (15.7)	93 (16.2)
Sinus	3 (1.0)	7 (2.4)	10 (1.7)
Other	2 (0.7)	2 (0.7)	4 (0.7)
Missing	5 (1.7)	3 (1.0)	8 (1.4)
Risk Factors*			
Recent history of prolonged neutropenia	179 (62.2)	189 (65.9)	368 (64.0)
Receipt of an allogenic HSCT	65 (22.6)	59 (20.6)	124 (21.6)
Treatment with other T-cell immune suppressants	126 (43.8)	109 (38.0)	235 (40.9)
Prolonged use of corticosteroid	93 (32.2)	89 (31.0)	182 (31.7)
Inherited severe immunodeficiency	2 (0.7)	1 (0.3)	3 (0.5)
None of the above	17 (5.9)	18 (6.3)	35 (6.1)

Source: Adapted from Tables 10-6 and 11-4 of P069 Clinical Study Report and confirmed by Reviewer using ADSL dataset

*Adjudicator's Assessment

Treatment Compliance, Concomitant Medications, and Rescue Medication Use

Treatment compliance was defined as the numbers of days a subject was on study medication of the total days the subject was assigned to study medication. Nearly all subjects (98.6%) in the ITT population received > 80% of assigned study therapy.

Table 8-7 summarizes study drug duration for the ITT population. The total duration of study drug (IV and/or oral) was similar between the treatment groups and was a median duration of 67 days for posaconazole and 64 days for voriconazole. Approximately 58% of the subjects started study treatment with the IV formulation. The median duration of IV dosing (before switching to oral or discontinuing or completing study treatment) was 9 days for both treatment groups; however, there was a wide range of IV study drug duration (1 to 81 days).

Table 8-7: Treatment Duration (ITT Population)

	Posaconazole (N=288)	Voriconazole (N=287)
Initial Route of Administration, n (%)		
IV infusion	161 (55.9)	171 (59.6)

Version date: October 12, 2018

	Posaconazole (N=288)	Voriconazole (N=287)
Oral	127 (44.1)	116 (40.4)
Total treatment duration		
Median duration (days)	67	64
Range	1 to 112	2 to 112
Total IV duration*		
Median duration (days)	9.0	9.0
Range	1 to 81	1 to 67

Source: Adapted from Tables 10-10, 10-11, and 10-12 of P069 Clinical Study Report

*For those who started on IV treatment

Almost all subjects in the ITT population (98.4%) reported the use of concomitant medication during the study. The incidence and type of concomitant medications were generally comparable between treatment groups. During the study, concomitant antifungal drugs for systemic use were reported for 173 (60.1%) posaconazole and 171 (59.6%) voriconazole subjects. While receiving study treatment, 29 (10.1%) posaconazole subjects and 28 (9.8%) voriconazole subjects also received concomitant antifungal drugs for systemic use. The most frequently received concomitant antifungal drugs for systemic use during the study treatment period were amphotericin B (topical, for mucositis) and fluconazole (for prophylaxis). The use of these concomitant antifungal drugs is not expected to have affected the assessment of the treatment of IA.

Efficacy Results – Primary Endpoint

All-cause mortality through Day 42 is summarized in Table 8-8. The ITT population was the protocol-defined primary analysis population for all-cause mortality through Day 42. In the ITT population, the all-cause mortality rate through Day 42 was 15.3% for posaconazole and 20.6% for voriconazole. The adjusted difference between treatment groups was -5.3% with a corresponding 95% confidence interval of (-11.6, 1.0). Since the upper bound of the 95% confidence interval is less than 10%, non-inferiority of posaconazole compared to voriconazole was demonstrated with respect to all-cause mortality through Day 42. Day 42 survival status was known for all subjects. The results for all-cause mortality through Day 42 in the FAS population were supportive of the ITT population.

Table 8-8: All-Cause Mortality through Day 42

Analysis Population	Posaconazole n/N (%)	Voriconazole n/N (%)	Difference (%) and 95% CI*
ITT	44/288 (15.3)	59/287 (20.6)	-5.3 (-11.6, 1.0)
FAS	31/163 (19.0)	32/171 (18.7)	0.3 (-8.2, 8.8)

Source: Adapted from Tables 11-5 and 11-6 in P069 Clinical Study Report and confirmed by Reviewer using ADSL dataset

*difference (Posaconazole- Voriconazole) and 95% confidence interval calculated using Miettinen and Nurminen's method

Version date: October 12, 2018

All-Cause Mortality at Day 42 by various subgroups is summarized in Table 8-9 for the ITT population. Interpretation of these results must be made with caution given lack of type 1 error control for multiple analyses and the limited sample size in some of the subgroup categories. All-cause mortality rates at Day 42 were generally comparable across treatment group for most subgroups and supportive of the overall population. A trend suggestive of nominally significantly lower mortality rates for posaconazole compared to voriconazole was observed for males, white subjects, subjects 18 to 64 years old, and those with a baseline adjudication of possible IA as the upper bound of the 95% confidence interval for these groups excluded 0. Overall, mortality was higher for subjects ≥ 65 years, those with proven IA at baseline, and those whose initial route of administration was with the IV infusion.

Table 8-9: All-Cause Mortality at Day 42 for Various Subgroups (ITT population)

Subgroup	Posaconazole n/N (%)	Voriconazole n/N (%)	Difference (%) and 95% CI*
Sex			
Male	21/172 (12.2)	38/172 (22.1)	-9.9 (-17.9, -1.9)
Female	23/116 (19.8)	21/115 (18.3)	1.6 (-8.7, 11.8)
Race			
White	29/194 (14.9)	47/192 (24.5)	-9.5 (-17.5, -1.6)
Black	0/3 (0.0)	0/4 (0.0)	-
Asian	10/62 (16.1)	4/60 (6.7)	9.5 (-2.1, 21.6)
American Indian or Alaska Native	0/4 (0.0)	4/6 (66.7)	-66.7 (-90.9, -1.5)
Multi-racial	5/25 (20.0)	4/25 (16.0)	4.0 (-18.5, 26.4)
Age (years)			
< 18	1/3 (33.3)	0/2 (0.0)	33.3 (-51.9, 82.0)
18 to 64	23/200 (11.5)	42/210 (20.0)	-8.5 (-15.6, -1.4)
≥ 65	20/85 (23.5)	17/75 (22.7)	0.9 (-12.5, 13.9)
Region			
Asia Pacific	9/61 (14.8)	4/60 (6.7)	8.1 (-3.3, 20.1)
Europe	24/149 (16.1)	37/147 (25.2)	-9.1 (-18.3, 0.2)
North America	5/43 (11.6)	7/39 (18.0)	-6.3 (-23.0, 9.6)
US	3/21 (14.3)	0/12 (0.0)	14.3 (-11.9, 35.0)
Ex-US	2/22 (9.1)	7/27 (25.9)	-16.8 (-37.8, 6.0)
South America	6/35 (17.1)	11/41 (21.8)	-9.7 (-28.0, 9.7)
Risk Status			
High Risk	20/113 (17.7)	23/113 (20.4)	-2.7 (-13.0, 7.7)
Not High Risk	24/175 (13.7)	36/174 (20.7)	-7.0 (-15.0, 1.0)
Aspergillosis Classification			
Proven	7/26 (26.9)	4/15 (26.7)	0.3 (-29.6, 26.5)
Probable	24/137 (17.5)	28/156 (17.9)	-0.4 (-9.2, 8.5)
Possible	7/81 (8.6)	18/79 (22.8)	-14.1 (-25.9, -3.0)
Cannot be determined	6/44 (13.6)	9/37 (24.3)	-10.7 (-28.7, 6.5)
Initial Route of Administration			
IV infusion	30/161 (18.6)	47/171 (27.5)	-8.9 (-17.8, 0.3)
Oral	14/127 (11.0)	12/116 (10.3)	0.7 (-7.5, 8.7)

Source: Reviewer conducted analyses using ADSL and ADBASE datasets

*Difference is posaconazole-voriconazole and 95% confidence interval is based on Miettinen and Nurminen's method

Version date: October 12, 2018

Efficacy Results – Secondary and other relevant endpoints

All-cause mortality rates through Day 84 are presented in Table 8-10. Comparable rates were observed in the posaconazole and voriconazole treatment groups in both the ITT and FAS populations. Day 84 survival status was known for all but 3 voriconazole ITT subjects (also in the FAS) who are imputed as deaths in these analyses. Since all of the subjects with unknown survival status were in the control arm, a sensitivity analysis was conducted by imputing these subjects as having survived. This results in a slight shift to the right of the estimates of the difference between treatment groups and corresponding 95% confidence interval.

Table 8-10: All-cause Mortality through Day 84

Analysis Population	Posaconazole n/N (%)	Voriconazole n/N (%)	Difference (%) and 95% CI*
ITT	81/288 (28.1)	88/287 (30.7)	-2.5 (-9.9, 4.9)
FAS	56/163 (34.4)	53/171 (31.0)	3.1 (-6.9, 13.1)
ITT-sensitivity**	81/288 (28.1)	85/287 (29.6)	-1.5 (-8.8, 5.9)
FAS-sensitivity**	56/163 (34.4)	50/171 (29.2)	4.8 (-5.1, 14.7)

Source: Adapted from Tables 11-7 and 14.2-5 in P069 Clinical Study Report and confirmed by Reviewer using ADSL dataset

*adjusted difference (Posaconazole- Voriconazole) and CI calculated on Miettinen and Nurminen's method

** Sensitivity analysis imputes 3 voriconazole subjects with unknown survival status as not having died.

The Kaplan-Meier plot for the cumulative all-cause mortality rate through the end of the study period (Day 114) for the ITT population is presented in Figure 8-1. During the treatment phase (through Day 84), there is a trend toward separation of the mortality curves favoring posaconazole. Overall, there was not a statistically significant difference between the treatments (log-rank p-value=0.7652).

Version date: October 12, 2018

Figure 8-1: Kaplan-Meier Plot for Cumulative All-Cause Mortality Through Day 114 (ITT Population)

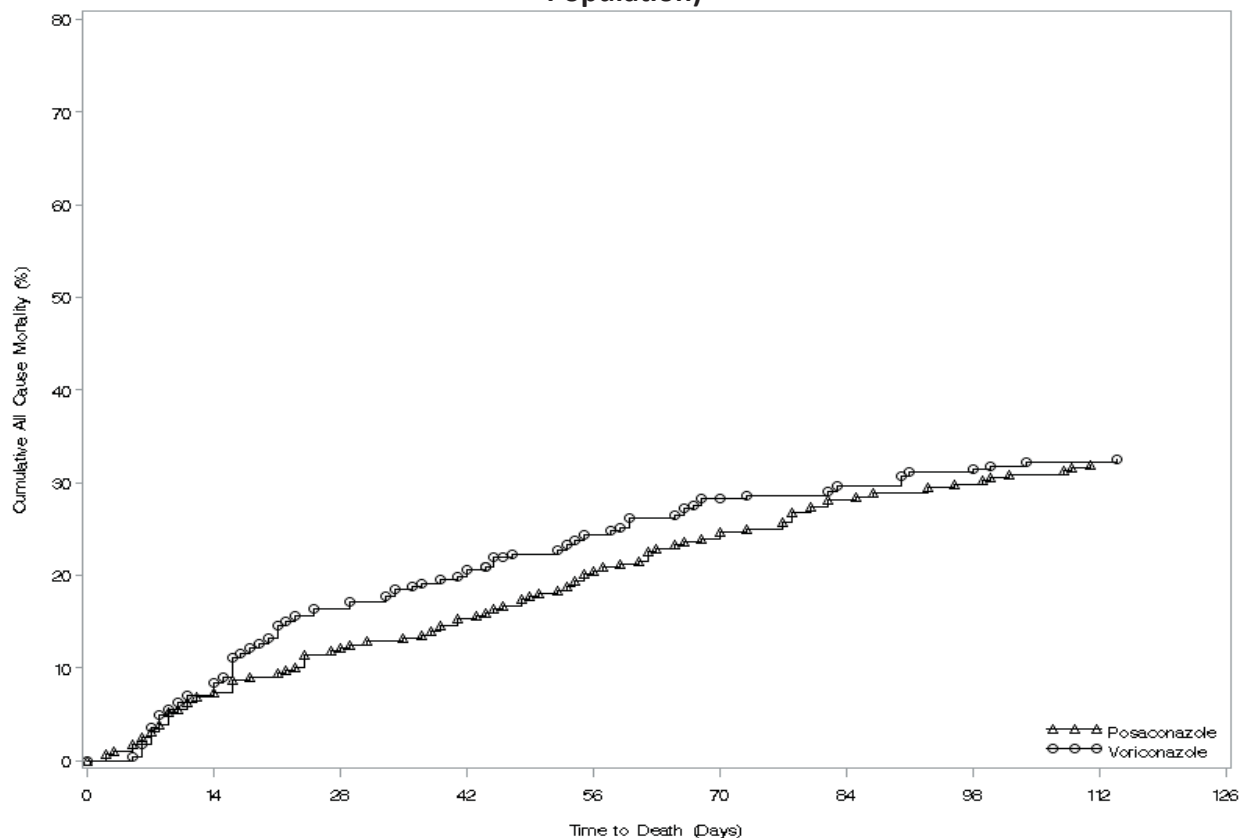

Source: Reviewer conducted analysis using ADTTE dataset

Global clinical response at Week 6 and Week 12 as assessed by the adjudicators is summarized in the Table 8-11. The proportion of subjects with a successful global clinical response at Week 6 was similar between the treatment groups. Partial response accounted for the majority of the successful responses in each treatment group. Death and progression of fungal infection accounted for the majority of the failures. It should be noted that Table 8-11 reports 4 more deaths (3 posaconazole and 1 voriconazole subjects) at Week 6 than reported in Table 8-8 for all-cause mortality at Day 42. These subjects died after Day 42 between Days 43 and 50 which is within the window of assessment for Week 6. For approximately 10% of subjects in each treatment group, the outcome could not be determined by the adjudicators and therefore these were counted as failures in the analysis.

The overall success/failure results at Week 12 were generally comparable to those at Week 6. While the overall proportion of successful response did not change much from Week 6 to Week 12 in either treatment group, the proportion of subjects assessed as a complete response increased in both treatment groups. Death accounted for the majority of the failures in both treatment groups. Numerically more voriconazole subjects than posaconazole subjects were

Version date: October 12, 2018

NDA Multi-disciplinary Review and Evaluation, sNDA 205596, 205053, 214770
 NOXAFIL® (posaconazole) injection, delayed release tablet, PowderMix
 For prophylaxis of invasive fungal infections in pediatric patients 2 years of age and older
 For treatment of invasive aspergillosis in adults and pediatric patients 13 years and older

classified as having progression of fungal infection. Whereas, numerically more posaconazole subjects died.

Table 8-11: Global Clinical Response at Week 6 and Week 12 FAS Population

Time Point Global Clinical Response	Posaconazole (N=163) n (%)	Voriconazole (N=171) n (%)	Difference (%) and 95% CI*
Week 6			
Success	73 (44.8)	78 (45.6)	-0.6 (-11.2, 10.1)
Complete	11 (6.7)	9 (5.3)	
Partial	62 (38.0)	69 (40.4)	
Failure	90 (55.2)	93(54.4)	
Stable	12 (7.4)	22 (12.9)	
Progression	27 (16.6)	21 (12.3)	
Death	34 (20.9)	33 (19.3)	
Unable to assess	17 (10.4)	17 (9.9)	
Week 12			
Success	69 (42.3)	79 (46.2)	-3.4 (-13.9, 7.1)
Complete	20 (12.3)	19 (11.1)	
Partial	49 (30.1)	60 (35.1)	
Failure	94 (57.7)	92 (53.8)	
Stable	9 (8.0)	7 (4.1)	
Progression	13 (8.0)	19 (11.1)	
Death	56 (34.4)	51 (29.8)	
Unable to assess	16 (9.8)	15 (8.8)	

Source: Adapted from Tables 11-10, 11-11, and 11-12 in P069 Clinical Study Report and confirmed by Reviewer using ADEFF dataset

*adjusted difference (Posa- Vori) and CI on Miettinen and Nurminen's method

8.2.3. Assessment of Efficacy Across Trials

There is only one trial submitted in support of the efficacy of posaconazole for the treatment of invasive aspergillosis.

8.2.4. Integrated Assessment of Effectiveness

The evidence to support the efficacy of posaconazole for the treatment of invasive aspergillosis was based on the single Phase 3 trial, Study P069. This trial showed that treatment with posaconazole was non-inferior to voriconazole with respect to all-cause mortality through Day 42. The all-cause mortality rate through Day 42 in the ITT population was 15.3% in the posaconazole group and 20.6% in the voriconazole group. The upper bound of the 95% confidence interval of the difference (posaconazole - voriconazole) was 1.0% and lower than the prespecified and justified 10% non-inferiority margin. The results are robust for the FAS population based on patients with proven or probable IA. The secondary endpoint of global clinical response at Week 6 in the FAS population was similar between treatment groups (44.8% for posaconazole and

Version date: October 12, 2018

NDA Multi-disciplinary Review and Evaluation, sNDA 205596, 205053, 214770
NOXAFIL® (posaconazole) injection, delayed release tablet, PowderMix
For prophylaxis of invasive fungal infections in pediatric patients 2 years of age and older
For treatment of invasive aspergillosis in adults and pediatric patients 13 years and older

45.6% for voriconazole) with a 95% confidence interval about the treatment difference of (-11.2%, 10.1%).

8.3. Statistical Issues

The assessment of efficacy of posaconazole for the treatment of invasive aspergillosis is one based on showing non-inferiority of posaconazole compared to voriconazole with respect to all-cause mortality at Day 42. A justification of a non-inferiority margin for use in IA trials with voriconazole as a comparator and the endpoint of all-cause mortality through Day 42 was conducted by the Division prior to the last approved treatment for IA (NDA 207500 for isavuconazole). Based on the data from the original registration trial 307/602 for voriconazole to estimate the response for voriconazole and a literature search to derive an estimate of the effect of placebo (no treatment), it was determined that an estimate of the M1 was approximately 52% to 58%. Therefore, a non-inferiority margin of 10% based on clinical judgment for M2 was determined to be acceptable for assessing all-cause mortality through Day 42. Since the study design, including patient population, of P069 is similar to that of Study 9766-CL-0104 conducted to support the approval of NDA 207500 as well as the original registration trial 307/602 for voriconazole, the 10% non-inferiority margin is appropriate for assessing the efficacy of posaconazole.

Version date: October 12, 2018

9 Clinical Microbiology Review

9.1. Nonclinical Microbiology

9.1.1. Mechanism of Action

Mechanism of Action

Posaconazole is a triazole that blocks the synthesis of ergosterol, a key component of the fungal cell membrane, through the inhibition of cytochrome P-450 dependent enzyme, lanosterol 14 α -demethylase responsible for the conversion of lanosterol to ergosterol in the fungal cell membrane. This results in an accumulation of methylated sterol precursors and a depletion of ergosterol within the cell membrane thus weakening the structure and function of the fungal cell membrane. The action is fungistatic.

9.1.2. Antibacterial Activity

Posaconazole is active against *Candida spp.* except *Candida krusei*, *Cryptococcus neoformans*, *Trichosporon spp.*, *Aspergillus spp.*, and *Zygomycetes*. Additionally, posaconazole demonstrated similar in vitro activity to itraconazole against dimorphic fungi (including *Blastomyces*, *Coccidioides spp.*, *Histoplasma* and *Penicillium*). Posaconazole has shown activity against strains of *Candida spp.*, and *Aspergillus spp.* that have shown resistance to fluconazole, voriconazole and itraconazole

9.1.3. Antibacterial Activity in Animal Models

Activity of an intravenous formulation of posaconazole in the prophylactic treatment of *A. fumigatus* pulmonary infections in immunocompromised mice is outlined below.

An IV formulation was evaluated for efficacy against *A.*

Appears this way on original

An IV formulation was evaluated for activity against *A. fumigatus* ND158 (MIC 0.125 μ g/mL) in two immunocompromised mouse models of pulmonary infection. The intranasal infection model used a liquid conidial suspension, while the inhalation flask model used a dry conidial cloud for inoculation of the mice. The inhalation flask model was used extensively in the early evaluations of oral POS against various *Aspergillus* strains. For *A. fumigatus* strain ND158, the doses that resulted in 50% survival were 29.9 and 2.6 mg/kg when the drug was administered therapeutically and prophylactically, respectively. The result of the studies with the POS IV formulation are shown in Fig. 1. The inocula in the two models were similar, 7.9x10⁶ CFU/mouse for the intranasal 7.2x10⁶ CFU/mouse for the inhalation flask model, as determined from lung burdens of model and untreated mice 1 hr postinfection. However, the inhalation flask model was more lethal (3 to 5 days for 100% lethality) than the intranasal model - 7 days for 100% lethality. The POS IV formulation was similarly protective against lethality in both models (Fig. 9-1). The highest dose tested, 25 mg/kg, resulted in 88 to 100% survival through 8 days postinfection in both models. The middle dose, 5 mg/kg, resulted in intermediate survival, 60 to 75% in the intranasal model and 25 to 38% in the inhalation flask model. The low dose, 1 mg/kg, provided 30 to 50% survival in

Version date: October 12, 2018

NDA Multi-disciplinary Review and Evaluation, sNDA 205596, 205053, 214770
NOXAFIL® (posaconazole) injection, delayed release tablet, PowderMix
For prophylaxis of invasive fungal infections in pediatric patients 2 years of age and older
For treatment of invasive aspergillosis in adults and pediatric patients 13 years and older

the intranasal model, and was completely ineffective (0% survival at day 4) in the inhalation flask model. The survival results were reflected in the lung burdens of the surviving mice.

Figure 9-1 The Effect of Posaconazole treatment in two immunocompromised mouse models infected with *A. fumigatus*

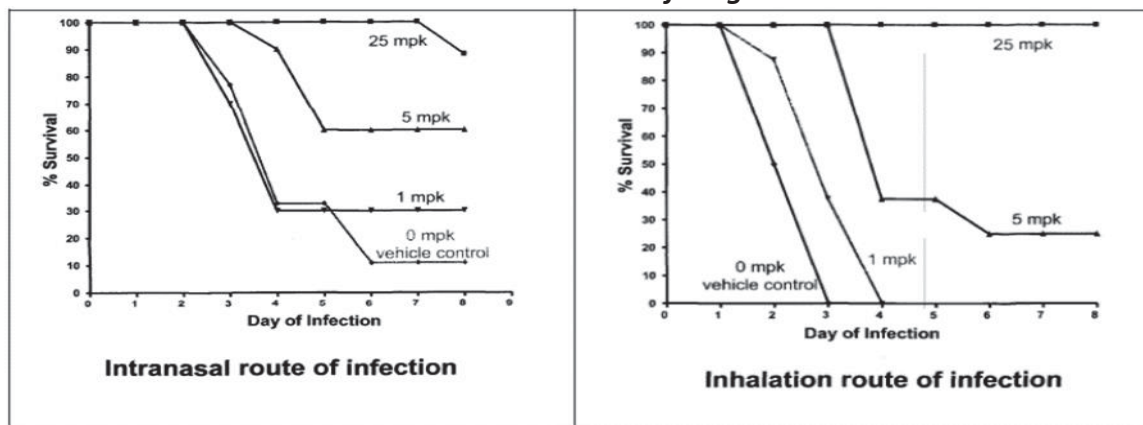

Version date: October 12, 2018

10 Safety Review

10.1. Safety Review Approach

These applications contain patient-level data from two clinical trials:

- 1) Study MK-5592-097 (Study P097), a pharmacokinetic, safety and tolerability study of intravenous (IV) POS and oral POS powder- for-suspension (POWDERMIX) for prophylaxis of invasive fungal infections in immunocompromised pediatric patients, 2 to 17 years of age.
- 2) Study MK-5592-069 (Study P069), a single multicenter, randomized, controlled phase 3 clinical trial of posaconazole injection/delayed-release tablets (POS) versus voriconazole injection/delayed-release tablets (VOR) in patients ≥ 13 years of age with invasive aspergillosis

The review of Study MK-5592-097 (hereafter referred to as Study P097), a PK, safety, and tolerability study of IV Posaconazole (hereafter referred to as "POS IV") and posaconazole powder for suspension (hereafter referred to as "POS POWDERMIX") in three dose cohorts (3.5mg/kg, 4.5mg/kg, and 6mg/kg) for prophylaxis of IFIs in immunocompromised pediatric patients 2-17 years of age with neutropenia or expected neutropenia., focused on the assessment of safety for the POS 6mg/kg daily dose proposed for marketing. Deaths, treatment emergent adverse events (TEAEs), serious adverse events (SAEs), and adverse events (AEs) of special interest associated with triazole drugs are evaluated and compared across age and dose cohorts for posaconazole treatment groups. Those TEAEs and SAEs that led to drug discontinuation, withdrawal, and/or death were evaluated in more depth. . Adverse events in Study P097 were compared to adverse events reported in adults and pediatric patients 13 years and older treated with posaconazole in adequate and well controlled prophylaxis trials as well as to the known safety profile of triazole antifungals. The sources of data used for this safety review include study reports, datasets, and literature references which can be found at the following link:

<\\CDSESUB1\evsprod\NDA205596\0090>.

In the review of Study MK-5592-069 (hereafter referred to as Study P069), treatment emergent adverse events (TEAEs), serious adverse events (SAEs), and adverse events (AEs) of special interest associated with azole antifungal drugs such as hepatic, central nervous system (CNS)/visual, and dermatologic adverse events, and abnormalities of adrenal steroidogenesis were analyzed and compared across POS and VOR treatment groups. Laboratory test abnormalities were compared between treatment groups and hepatic laboratory data were examined for evidence of drug induced liver injury. TEAEs and SAEs that led to study drug discontinuations or dosing interruptions were evaluated and analyses of TEAEs were performed by sex, race, and region and in special populations such as elderly patients.

The sources of data used include a clinical study report, clinical datasets, and literature references at the following link: <\\CDSESUB1\evsprod\NDA205596\0092>

Version date: October 12, 2018

The reviewer acknowledges Scott G. Runyan, B.S., Senior Analyst, JReview Support Team, for his contribution to several analyses of clinical laboratory data presented in this review.

10.2. Study P097: A Study of the Safety, Tolerability, and Pharmacokinetics of Intravenous and for Delayed-release Oral Suspension Formulations of Posaconazole in Immunocompromised Pediatric Subjects with Neutropenia

10.2.1. Pediatric Development Rationale: Formulation and Scope of Clinical Program

The FDA review of pharmacokinetic data from adult prophylactic studies with POS oral suspension established that at a steady state posaconazole exposure (Cavg) range of 700 to 2500 ng/ml efficacy for IFI prophylaxis indication is maximized. A lower limit of 500 ng/ml was used for the approval of Noxafil Injection and delayed release tablet formulations for the indication of IFI prophylaxis as for the Cmin (injection, tablet dosed daily) to Cavg (oral suspension dosed three times daily) comparison this limit was deemed conservative. The target range and mean steady state Cavg of 500ng/mL to 2500 ng/mL and ~ 1200ng/mL, respectively, were retained for pediatric development program as the original oral suspension formulation (b) (4) is dosed three times daily, had high variability in systemic exposure, and achieving at least of 700 ng/ml in 90% of pediatric patients using that formulation did not appear feasible.

Pediatric studies of POS oral suspension demonstrated that the target exposure range was achieved only in 50% of pediatric patients.

A new pediatric POWDERMIX formulation was developed to have a more favorable bioavailability/PK profile. A prototype of this new formulation was initially tested in healthy adult volunteers (Study PN106) to compare the PK of the POS POWDERMIX to POS delayed-release tablet; the analysis of the PK data confirmed comparable plasma PK exposure between POWDERMIX and tablet as well as adequate tolerability.

Reviewer's Comment: *With the advent of a new pediatric formulation, POS POWDERMIX that is dosed once daily and displays better and consistent bioavailability, the review team determined that 700ng/mL instead of 500 ng/ml should be used as the lower limit for target Cavg range in pediatric patients receiving POS POWDERMIX. See Clinical Pharmacology Section 6 for details.*

10.2.2. Sources of Clinical Data

See Section 7.1

Version date: October 12, 2018

10.2.3. Study Design

Study MK-5592-097 is a PK, safety, and tolerability study of IV Posaconazole (hereafter referred to as “POS IV”) and posaconazole powder for delayed release oral suspension (hereafter referred to as “POS POWDERMIX”) for prophylaxis of IFIs in immunocompromised pediatric patients with neutropenia or expected neutropenia. This was a nonrandomized, open-label study evaluating three dose cohorts (3.5mg/kg, 4.5mg/kg, and 6mg/kg) in 2 pediatric age groups (2 to <7years old and 7 to 17 years old) conducted at 24 centers in multiple countries.

Study Procedure

IV POS was administered BID on day 1 as a loading dose followed by once daily on days 2-10 (minimum 10 days) and then switched to POS POWDERMIX for a minimum of 10 days if still neutropenic. If subjects were unable to tolerate/refused oral medication they were given the option of remaining on POS IV beyond 10 days with permittance to oral transition any time through day 18 and/or completion of study. POS POWDERMIX may have been continued beyond 10 days if a subject remained neutropenic. A maximum of 300mg per dose was administered and the maximum duration of POS IV +/- POS POWDERMIX was 28 days. Safety follow up extended to 14 days after EOT, and survival assessment was performed between Days 90-110.

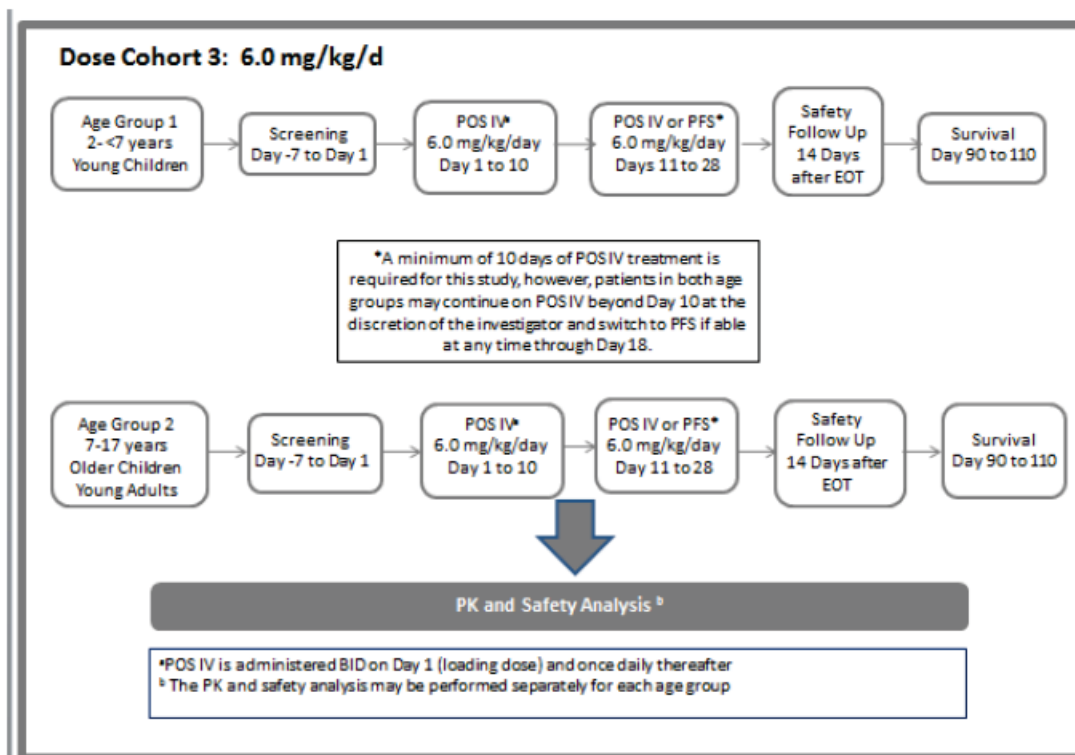

Source: Figure 9-1 Study Diagram of CSR

Inclusion Criteria

Version date: October 12, 2018

NDA Multi-disciplinary Review and Evaluation, sNDA 205596, 205053, 214770

NOXAFIL® (posaconazole) injection, delayed release tablet, PowderMix

For prophylaxis of invasive fungal infections in pediatric patients 2 years of age and older

For treatment of invasive aspergillosis in adults and pediatric patients 13 years and older

Eligible patients included pediatric patients aged 2 to 17 years with a specified hematologic/oncologic disorder (i.e. acute leukemia, myelodysplasia, severe aplastic anemia, recipients of autologous HSCT, high risk neuroblastoma, advanced stage non-Hodgkin's lymphoma (NHL), recipients of allogeneic HSCT during the pre-engraftment (neutropenic) period, hemophagocytic lymph histiocytosis) and subsequent documented or anticipated and persistent (expected to last for at least 7 days from initiation of study) neutropenia (ANC <500/mm³ [0.5 x 10⁹]) with a central line in place prior to beginning IV therapy and written, informed guardian/parental consent. Additionally, patients of reproductive age lacking sterility were required to remain abstinent or use acceptable birth control during the study.

Exclusion Criteria

Patients were excluded from the study if they had a proven or probable IFI (per 2008 EORTC/MSG consensus criteria) had received POS within ten days or any prohibited drugs (whether prior to or expected during study), had abnormal screening labs (AST >5x ULN, ALT >5xULN, total bilirubin (Tbili) >2.5x ULN, AST or ALT >3xULN AND serum Tbili 2x ULN, CrCl calculated <30mL/min), had prolonged screening QTc (using Fridericia or Bazett's correction and defined as >450msec for males or >470msec for females or >500msec for anyone), were pregnant, breastfeeding, or had plans to become pregnant during study, had a history of azole-related anaphylaxis, or had an additional clinical condition that in the opinion of the investigator would interfere with the study (i.e. would not receive expected minimum duration of study drug, previous participation, previous phase 1 clinical study participation for an IND (30 days prior or 60 days after randomization), or had known family member involved with study).

Study Endpoints

Primary: Evaluation of PK of and POS IV and POWDERMIX in immunocompromised pediatric patients age 2 to 17 with expected or actual neutropenia.

Secondary: Evaluation of safety and tolerability of POS IV and POWDERMIX in immunocompromised pediatric patients age 2 to 17 years of age with expected or actual neutropenia by adverse events, lab abnormalities (hematology and chemistry specifically), vital signs, and electrocardiogram (ECG) results as well as POS POWDERMIX palatability and acceptability.+

No formal efficacy endpoints were proposed in this study.

Statistical Analysis Plan

A non-compartmental analysis (NCA) was conducted on the primary pharmacokinetic (PK) population. The primary PK population is defined as the total number of subjects who received 7 or more days of POS IV solution and 7 days of POS POWDERMIX and completed full POS PK sampling.

Version date: October 12, 2018

NDA Multi-disciplinary Review and Evaluation, sNDA 205596, 205053, 214770

NOXAFIL® (posaconazole) injection, delayed release tablet, PowderMix

For prophylaxis of invasive fungal infections in pediatric patients 2 years of age and older

For treatment of invasive aspergillosis in adults and pediatric patients 13 years and older

A NCA of POS concentration-time profiles of the primary PK population was completed to determine the following PK parameters: C_{max}, T_{max}, C_{avg}, AUC, CL, and CL/F.

A population PK analysis was done “to characterize POS PK and assess potential covariates” following administration of POS IV and POWDERMIX.

Safety analyses were conducted on the safety population defined as the total number of subjects who received at least one dose of the study drug.

All results were descriptive as there was no formal hypothesis to be tested in this study.

Protocol Amendments

Amendment 1 (February 2015): changed POWDERMIX formulation from granules to powder, changed the dose for the first dose cohort from 3 mg/kg to 3.5 mg/kg, and removed requirement for a fasted state at the time of study drug administration.

Amendment 2 (May 2017) added a third dose cohort (6mg/kg) based on review of the PK data from dose cohorts 1 and 2 (3.5mg/kg and 4.5mg/kg, respectively). Although the 4.5mg/kg dose cohort successfully achieved PK target ~90% subjects having steady state C_{avg} concentration between specified 500ng/mL to 2500ng/mL for both IV and POWDERMIX formulations, the overall exposures (as measured by mean C_{avg} concentrations) were noted to be 30-40% lower than corresponding values in adult studies of the delayed-release tablet. The 6mg/kg dose cohort and an increase in the minimum enrollment were thus implemented to better match adult systemic target exposures and to augment the safety database.

10.2.4. Study Results

Compliance with Good Clinical Practices

The Applicant certified that Study P097 was conducted in compliance with GCP.

Data Quality and Integrity

The study under review was determined to be low risk as no efficacy assessments were performed; no clinical inspections were recommended. The review of the clinical and clinical pharmacology data submitted did not identify any data quality/integrity issues.

Dosing Regimen

The study protocol stated that POS POWDERMIX dose may be administered by oral syringe or via a feeding tube and should be prepared and administered using the Sponsor supplies as outlined in the Pharmacy Manual.

Reviewer’s Comment: *It should be noted, however, that the DMEPA review of the POS POWDERMIX Human Factor validation study indicated multiple drug administration issues related*

Version date: October 12, 2018

to the viscosity of the constituted suspension, notched tip syringe, air bubbles,+/- comprehension of the preparation/administration instructions, which impacted the precision in administering doses greater than 8mL (240 mg) (excursions ±12.5%) (b) (4)

, it is unclear whether patients weighing greater than 40kg who were given POWDERMIX doses ranging from greater than 240mg (8mL) to 300 mg (10mL) were able to receive the full calculated POS POWDERMIX dose, and if so, how these doses were administered and why there is a seeming discrepancy given the fact that all subjects/caregivers were reportedly using the same supplies/instructions for preparation/administration as proposed for marketing.

Financial Disclosure

There were no financial disclosure to report. Refer to section 15.1 for details.

Patient Disposition

Among the 118 subjects enrolled in the study, 115 subjects received at least one dose of the study drug. Six subjects were withdrawn from the study, 2 because of death, 2 because of a physician decision, 1 because of an adverse event, and 1 because of a protocol deviation, **Error! Reference source not found.** Eighteen of these subjects experienced adverse events leading to study drug discontinuations, 14 subjects discontinued the study drug due to physician decision, 3 due to withdrawal by a parent/guardian, and 2 were due to protocol deviation.

Table 10-1 Disposition of Study Subjects

	Treatment 3.5 mg/kg		Treatment 4.5 mg/kg		Treatment 6 mg/kg		Total	
	2-<7 (N=14)	7-17 (N=21)	2-<7 (N=15)	7-17 (N=16)	2-<7 (N=19)	7-17 (N=30)	2-<7 (N=48)	7-17 (N=67)
DISPOSITION								
ENROLLED	14 (100.0)	21 (100.0)	15 (100.0)	16 (100.0)	19 (100.0)	30 (100.0)	48 (100.0)	67 (100.0)
STUDY WITHDRAWAL	0	1 (4.8)	1 (6.7)	0	1 (5.3)	3 (10.0)	2 (4.2)	4 (6.0)
DEATH	0	0	0	0	1 (5.3)	1 (3.3)	1 (2.1)	1 (1.5)
PHYSICIAN DECISION	0	1 (4.8)	1 (6.7)	0	0	0	1 (2.1)	1 (1.5)
ADVERSE EVENT	0	0	0	0	0	1 (3.3)	0	1 (1.5)
PROTOCOL DEVIATION	0	0	0	0	0	1 (3.3)	0	1 (1.5)
STUDY DRUG	14 (100.0)	20 (95.2)	14 (93.3)	16 (100.0)	18 (94.7)	27 (90.0)	46 (95.8)	63 (94.0)

Source: OCS Analysis Studio Custom Table Tool.
 Columns - Dataset: Demographics; Filter: TRTFL = "Y".
 Disposition by Study, Completed, Discontinued - Dataset: Disposition; Filter: DSDECOD = 'ADVERSE EVENT' or 'COMPLETED' or 'WITHDRAWAL BY PARENT/GUARDIAN' or 'PHYSICIAN DECISION' or 'PROTOCOL DEVIATION' or 'SCREEN FAILURE' or 'DEATH'.
 Disposition by Event and Subcategory - Dataset: Disposition; Filter: DSCAT = 'DISPOSITION EVENT'.
 Disposition with Subject Identifiers (excluding completed) - Dataset: Disposition; Filter: DSDECOD = 'ADVERSE EVENT' or 'WITHDRAWAL BY PARENT/GUARDIAN' or 'PHYSICIAN DECISION' or 'PROTOCOL DEVIATION' or 'SCREEN FAILURE' or 'DEATH'.
 Disposition - Dataset: Disposition; Filter: DSDECOD = 'ADVERSE EVENT' or 'COMPLETED' or 'WITHDRAWAL BY PARENT/GUARDIAN' or 'PHYSICIAN DECISION' or 'PROTOCOL DEVIATION' or 'SCREEN FAILURE' or 'DEATH'.

Protocol Violations/Deviations

There were 45 subjects (39.1%) with reported, significant protocol deviations, 12 of whom had

Version date: October 12, 2018

deviations related to the study drug: 10 affected POS IV dosing and 2 affected POS POWDERMIX dosing. Of the 115 subjects started on POS IV, 15 (13%) were not included in PK analyses because they did not meet *patient acceptability criteria* (9 due to PK concentration levels not being obtained, 5 due to dose not being given within 6 hours of scheduled time, and 1 was excluded as an outlier). Of the 63 subjects successfully transitioned to POS POWDERMIX, 13 (20.6%) were not included in PK analyses because they did not meet *patient acceptability criteria* (10 due to PK concentrations or samples not being collected and 3 due to incomplete doses being taken). Of the 63 subjects successfully transitioned to POS POWDERMIX, 50 were included in the PK analysis with the following breakdown by dose cohort:

- 15/17 (88%) in 3.5mg/kg (5/6 (83%) in age group 1 and 10/11 (90%) in age group 2)
- 16/18 (88%) in 4.5 mg/kg (8/9 (88%) in age group 1 and 8/9 (88%) in age group 2)
- 19/28 (67%) in 6mg/kg (7/14 (50%) in age group 1 and 12/14 (85.7%) from age group 2)

Not all subjects with important study intervention-related deviations were excluded from the PK analysis. Subjects with deviations affecting study intervention were only excluded from PK analyses based on the timing and nature of the deviation and if the subject did not satisfy the prespecified Patient Acceptability Criteria.

Ten subjects in POWDERMIX treatment group did not have the 24-hour PK sample making AUC₀₋₂₄ and C_{avg} calculations impossible. Based upon the assumption, however, that steady state PK concentrations are achieved by Day 7, the pre-dose samples were taken to be equivalent to the 24-hour PK sample and applied to support estimation of AUC 0-24 and consequently C_{avg}. Additionally, the PK profile of one subject was excluded from the primary analysis but included in a sensitivity analysis after demonstrating a prominent rise to C_{max} followed by a rapid decline to C_{min}: an inconsistent pattern to the known PK profile of POS that is relatively flat with minor C_{max} to C_{min} fluctuations and slow elimination. The PK analysis population included a total of 100 subjects for POS IV and 50 subjects for POWDERMIX. A population PK analysis was also conducted separately. No important protocol deviations were classified as GCP compliance issues.

Reviewer's Comment: Only 67% of all subjects who received (b) (4) POS POWDERMIX 6mg/kg, (as compared to 88% of subjects in both 3.5mg/kg and 4.5mg/kg dose cohorts were included in the PK analyses. Only 50% of subjects in Age Group 1 of the 6mg/kg POS POWDERMIX dose cohort (compared to 83% and 88% in Age Group 1 of 3.5mg/kg and 4.5mg/kg dose cohorts, respectively) were included in the PK analyses. The seemingly disproportionate exclusion of subjects from the 6mg/kg dose cohort, particularly in Age Group 1, is of unclear significance given the small sample size, but should be noted.

Demographic and Other Baseline Characteristics

Error! Reference source not found. displays demographic characteristics of patients in the safety analysis set. There were no clinically meaningful differences in demographics/underlying disease characteristics observed between dose cohorts. The majority of subjects were white (83.5%), not

Version date: October 12, 2018

Hispanic or Latino (87%) and male (58.3%) with a median age of 8 years old and with the most common underlying premedical qualifying conditions being acute leukemia (44.3%), HSCT (44.3%), and high risk neuroblastoma (13.9%).

Table 10-2 Baseline Characteristics All Subjects as Treated

	Treatment 3.5 mg/kg Age Group1 (2-<7 years) n (%)	Treatment 3.5 mg/kg Age Group2 (7-17 years) n (%)	Treatment 4.5 mg/kg Age Group1 (2-<7 years) n (%)	Treatment 4.5 mg/kg Age Group2 (7-17 years) n (%)	Treatment 6 mg/kg Age Group 1 (2-<7 years) n (%)	Treatment 6 mg/kg Age Group 2 (7-17 years) n (%)	Total n (%)
Subjects in Population [†]	14	21	15	16	20	29	115
Gender							
Male	12 (85.7)	10 (47.6)	7 (46.7)	9 (56.3)	10 (50.0)	19 (65.5)	67 (58.3)
Female	2 (14.3)	11 (52.4)	8 (53.3)	7 (43.8)	10 (50.0)	10 (34.5)	48 (41.7)
Age (Years)							
Mean	3.93	13.86	4.07	12.19	3.85	12.00	8.93
SD	1.44	2.08	1.44	2.48	1.60	3.47	4.95
Median	3.00	14.00	4.00	12.00	3.50	12.00	8.00
Range	2 to 6	10 to 17	2 to 6	7 to 16	2 to 7	7 to 17	2 to 17
Race							
Asian	4 (28.6)	1 (4.8)	2 (13.3)	2 (12.5)	1 (5.0)	1 (3.4)	11 (9.6)
Black Or African American	0 (0.0)	0 (0.0)	0 (0.0)	0 (0.0)	1 (5.0)	2 (6.9)	3 (2.6)
Multiple	0 (0.0)	2 (9.5)	0 (0.0)	2 (12.5)	0 (0.0)	0 (0.0)	4 (3.5)
Native Hawaiian Or Other Pacific Islander	0 (0.0)	0 (0.0)	1 (6.7)	0 (0.0)	0 (0.0)	0 (0.0)	1 (0.9)
White	10 (71.4)	18 (85.7)	12 (80.0)	12 (75.0)	18 (90.0)	26 (89.7)	96 (83.5)
Ethnicity							
Hispanic Or Latino	1 (7.1)	2 (9.5)	2 (13.3)	4 (25.0)	1 (5.0)	2 (6.9)	12 (10.4)
Not Hispanic or Latino	13 (92.9)	19 (90.5)	12 (80.0)	11 (68.8)	18 (90.0)	27 (93.1)	100 (87.0)
Not Reported/Unknown	0 (0.0)	0 (0.0)	1 (6.7)	1 (6.3)	1 (5.0)	0 (0.0)	3 (2.6)
Specific Baseline Disease^{††}							
Acute Leukemia	3 (21.4)	8 (38.1)	4 (26.7)	11 (68.8)	8 (40.0)	17 (58.6)	51 (44.3)
Myelodysplasia	0 (0.0)	0 (0.0)	1 (6.7)	1 (6.3)	0 (0.0)	2 (6.9)	4 (3.5)
Severe Aplastic Anemia	3 (21.4)	3 (14.3)	3 (20.0)	1 (6.3)	2 (10.0)	1 (3.4)	13 (11.3)
Recipients of HSCT	7 (50.0)	13 (61.9)	9 (60.0)	2 (12.5)	7 (35.0)	13 (44.8)	51 (44.3)
High Risk Neuroblastoma	2 (14.3)	0 (0.0)	5 (33.3)	2 (12.5)	5 (25.0)	2 (6.9)	16 (13.9)
Advanced stage NHL	0 (0.0)	1 (4.8)	0 (0.0)	1 (6.3)	0 (0.0)	0 (0.0)	2 (1.7)

Version date: October 12, 2018

	Treatment 3.5 mg/kg Age Group1 (2-<7 years) n (%)	Treatment 3.5 mg/kg Age Group2 (7-17 years) n (%)	Treatment 4.5 mg/kg Age Group1 (2-<7 years) n (%)	Treatment 4.5 mg/kg Age Group2 (7-17 years) n (%)	Treatment 6 mg/kg Age Group 1 (2-<7 years) n (%)	Treatment 6 mg/kg Age Group 2 (7-17 years) n (%)	Total n (%)
Hemophagocytic Lymphohistiocytosis	1 (7.1)	0 (0.0)	0 (0.0)	0 (0.0)	0 (0.0)	1 (3.4)	2 (1.7)
Other [‡]	0 (0.0)	1 (4.8)	1 (6.7)	0 (0.0)	0 (0.0)	0 (0.0)	2 (1.7)
Weight (kg)							
Mean	18.61	53.40	17.42	49.02	17.43	46.25	35.80
SD	7.26	14.72	3.69	21.11	5.12	23.16	22.13
Median	15.85	51.50	17.60	44.20	16.40	39.30	28.60
Range	12.8 to 41.7	24.7 to 83.3	12.3 to 24.4	21.3 to 95.8	10.2 to 28.6	18.2 to 101.6	10.2 to 101.6
Height (cm)							
Mean	103.82	160.62	105.81	153.39	104.20	153.22	133.97
SD	11.68	14.36	11.50	15.98	13.86	23.54	30.34
Median	100.00	160.00	109.00	156.00	102.00	150.00	132.00
Range	87 to 122.5	133 to 189.6	81.6 to 119	125 to 182	83 to 130	114 to 195	81.6 to 195
<p>[†] 3 subjects were enrolled but not treated.</p> <p>^{††} It is possible for a subject to have more than one condition. Subjects with multiple conditions will be counted once in each condition. Subjects who do not have any of these 7 specific diseases reported will be counted in Other category.</p> <p>[‡] Baseline disease for the 2 subjects categorized as Other were alveolar rhabdomyosarcoma, and receipt of an autologous bone marrow transplantation.</p> <p>H SCT= hematopoietic stem cell transplantation, NHL=non-Hodgkin's lymphoma.</p> <p>Weight and height are summarized using the last observation prior to the first dose of study drug.</p>							

Source: Adapted from the Study report P097

NDA Multi-disciplinary Review and Evaluation, sNDA 205596, 205053, 214770
NOXAFIL® (posaconazole) injection, delayed release tablet, PowderMix
For prophylaxis of invasive fungal infections in pediatric patients 2 years of age and older
For treatment of invasive aspergillosis in adults and pediatric patients 13 years and older

Treatment Compliance, Concomitant Medications, and Rescue Medication Use

No rescue or supportive medications were specified to be used in this trial. Subjects who developed superficial fungal infections (e.g. cutaneous, thrush, *Candida* vaginitis), were permitted to be treated with topical antifungal agents and continued on study drug pending no further systemic involvement or more extensive mucosal involvement. There was also no diet or activity restrictions; however, information was collected during POS POWDERMIX treatment including timing of the study drug dose, type of meal consumed (if any), and timing of the meal relative to the study medication.

Reviewer's Comment: *Interestingly neither of the adult studies of POS for IFI prophylaxis prohibited the use of systemic antifungals one of which had a significantly larger proportion of patients placed on systemic antifungals compared to the other that might have had an impact on the exposure response for efficacy. In this study, it should also be noted that systemic antifungal therapy used for treatment of IFI required a minimum 30-day washout period (with deviations requiring approval by the Sponsor); however, other systemic antifungal therapy (oral, IV, or nasal/inhaled) used for prophylaxis of IFI did not require any specified washout period. Depending on the dose/timing of each antifungal (compared to treatment dose/timing) and a specific antifungal used, the number of breakthrough fungal infections reported could potentially be lower than that may have been reported otherwise.*

Safety Review Approach:

See Pediatric subsections titled Sources of Clinical Data and Review Strategy.

Review of Safety Database

Overall Exposure

The safety population included all 115 subjects who received at least one dose of posaconazole. The mean overall treatment duration was 20.6 days (median 22 and range 1-28 days) for both POS IV and POS POWDERMIX with a mean duration of exposure of POS IV of 14.3 days (median 13 range 1-28 days) and of POS POWDERMIX of 11.6 days (median 10 days, range 2-18 days). All 115 subjects were dosed with IV solution of whom 109 (94.8%) received at least 7 days of therapy. Sixty-three subjects were transitioned to POS POWDERMIX of whom 57 (90.5%) received at least 7 days of therapy.

Adequacy of Safety Database

The size of the safety database in Study P097 was considered adequate although relatively small (N = 115 patients) to assess the safety of posaconazole in pediatric patients aged 2 to less than 18 years of age. Additional relevant safety data for the delayed-release tablet from the invasive aspergillosis treatment trial in pediatric patients were limited to 3 subjects aged 14 to 17 years.

Only 49 (43%) of the 115 subjects received the proposed dose for marketing of 6mg/kg (20 in group 1 and 29 in group 2) with a cap of 300mg per dose.

Version date: October 12, 2018

Adequacy of Applicant’s Clinical Safety Assessments

Categorization of Adverse Events:

Definitions of adverse events (AEs) and serious adverse events (SAEs) in the clinical protocol were standard regulatory definitions. Summary of all AEs is included in **Error! Reference source not found..** Adverse events were coded using MedDRA version 21.0. Treatment emergent AEs (TEAEs) were those occurring from day 1 of study drug to those occurring up to 14 days after the last dose of the study drug. Study Days are numbered from the first day of IV treatment.

SAEs defined as any AE occurring at any dose or during any use of study drug that results in death, is life-threatening, results in persistent or significant disability/incapacity, results in or prolonged an existing inpatient hospitalization, is a congenital anomaly/birth defect, is another important medical event, is a new cancer, is associated with an overdose. Progression of cancer while on study drug was not considered an adverse event unless it resulted in hospitalization or death (unless outside of AE reporting period – through 14 days following cessation of treatment). Any grade 3 or 4 leukopenia, absolute neutropenia, or thrombocytopenia or any grade 1, 2, or 3 decrease in hemoglobin were not considered a serious adverse event.

The Coding dictionary used by the Applicant and translation of verbatim terms to PTs was deemed appropriate by the reviewer.

AEs occurred in 98% subjects (113 out of 115 subjects).

Reviewer’s Comment: In several analyses, PTs were pooled into group query terms by the reviewer for more accurate analysis, e.g. elevated liver tests included elevated AST, elevated ALT, and elevated transaminases. Details are specified in footnotes of corresponding tables with pooled PTs marked and noted by an asterisk.

Table 10-3: Summary of Adverse Events by Age and Dose Cohorts

	3.5 mg/kg: Age Group 1 (2-<7) n=14 (%)	3.5 mg/kg: Age Group 2 (7-17) n=21(%)	4.5 mg/kg: Age Group 1 (2-<7) n=15 (%)	4.5 mg/kg: Age Group 2 (7-17) n=16 (%)	6 mg/kg: Age Group 1 (2-<7) n=20 (%)	6 mg/kg: Age Group 2 (7-17) n=29 (%)	Totals n=115(%)
Subjects with at least 1 TEAE	13 (93)	21 (100)	15 (100)	16 (100)	19 (95)	29 (100)	113 (98)
Subjects with TEAE Drug Discontinuation	3 (21)	3 (14)	0	2 (13)	4 (20)	6 (21)	18 (16)
Subject with TEAE leading to Death	0	0	0	0	0	2 (7)	2 (2)
Subjects with at least 1 SAE	3 (21)	8 (38)	4 (27)	5 (31)	3 (15)	8 (28)	31 (27)
Subjects with SAE leading to Death	0	0	0	0	0	2 (7)	2 (2)
Subjects with SAE Drug Discontinuation	2 (14)	2 (10)	0	1 (6)	2 (10)	3 (10)	10 (9)

Version date: October 12, 2018

NDA Multi-disciplinary Review and Evaluation, sNDA 205596, 205053, 214770
NOXAFIL® (posaconazole) injection, delayed release tablet, PowderMix
For prophylaxis of invasive fungal infections in pediatric patients 2 years of age and older
For treatment of invasive aspergillosis in adults and pediatric patients 13 years and older

Source: Reviewer's Analysis (Analysis Studio)

Routine Clinical Tests

Per protocol, hematology and chemistry laboratory tests were collected and included at each visit.

Safety Results

Deaths

There were four deaths in the study. Two of these deaths were thought to be due to patients' underlying malignancy but were not reported as AEs since they occurred outside of the AE study drug monitoring period (greater than 14 days after the last dose was given). The other two deaths that were reported as AEs (1.7%) both occurred in the 6mg/kg Age Group 2 (7-17 year old) dose cohort.

Reviewer's Comment: *The exclusion of the two deaths occurring due to progression of the underlying malignancy would be considered a deviation from initial protocol had these occurred within the AE monitoring period. Since they occurred greater than 14 days after the last dose of study drug, their exclusion from adverse event categorization is reasonable.*

One of the two deaths reported as an adverse event was a 10 year old Hispanic white male with ALL and HTN who recently underwent HSCT (exact date unknown) and died of grade 5 venoocclusive disease (VOD) on Day 30. This subject had received 6 days of POS IV therapy before it was discontinued. He developed two SAEs: grade 4 capillary leak VOD on Day 6.

Reviewer's Comment: *Although the patient's death occurred on Day 30, well after drug discontinuation on Day 6, and it is most likely that patient's VOD was multifactorial and primarily related to his recent HSCT, POS-related causality cannot be definitely excluded as he developed VOD on Day 5 which ultimately was determined to be his cause of death while on POS.*

The second death occurred in a 16-year-old African American male who was post-HSCT (exact date unknown) and developed two serious adverse events: grade 3 stomatitis on Day 1 and grade 5 respiratory failure on Day 19. His cause of death was determined to be respiratory failure (grade 6) on Day 49. On Day 6, the patient received his last dose of POS IV and was started on amphotericin due to neutropenic fever. On Day 18, his febrile neutropenia resolved. On Day 19, the subject developed respiratory distress with tachypnea, increased work of breathing, and hypoxia, requiring increasing respiratory support. He was diagnosed with respiratory failure and transferred to the PICU where he was noted to have bilateral multifocal lung opacities as well as a pericardial effusion and he died due to respiratory failure on Day 49.

Reviewer's Comment: *As the subject's respiratory status stabilized on Day 3 (enough to be de-escalated from PICU) and the study drug was discontinued on Day 6, his death due to recurrent respiratory failure on Day 49 (originally occurring 13 days post drug discontinuation on Day 19), is unlikely to be drug-related.*

Version date: October 12, 2018

Serious Adverse Events

Overall, 27% of subjects had serious adverse events (SAEs), 10 (9%) of which led to study drug discontinuation. The most common SAE was febrile neutropenia. Serious adverse events for all dose cohorts listed by PT in descending order of incidence for those occurring in the 6mg/kg dose cohort are summarized in Table 11-4:

Table 10-4 Serious Adverse Events listed by PT in Descending Order of Incidence in 6mg/kg Dose Cohort

Preferred Term	3.5mg/kg		4.5mg/kg		6mg/kg		Total
	(N=35)		(N=31)		(N=49)		(N=115)
	n	(%)	n	(%)	n	(%)	n(%)
Febrile neutropenia	1	(3)	0		2	(4)	3 (3)
Vomiting	0		0		2	(4)	2 (2)
Venoocclusive disease	1	(3)	0		1	(2)	2(2)
Abdominal pain	0		0		1	(2)	1 (1)
Acute kidney injury	0		0		1	(2)	1 (1)
Capillary leak syndrome	0		0		1	(2)	1 (1)
Device related infection	0		0		1	(2)	1 (1)
Hypertension	0		0		1	(2)	1 (1)
Parainfluenzae virus infection	0		0		1	(2)	1 (1)
Posterior reversible encephalopathy syndrome	0		0		1	(2)	1 (1)
Respiratory failure	0		0		1	(2)	1 (1)
Stomatitis	0		0		1	(2)	1 (1)
Transplant rejection	0		0		1	(2)	1 (1)
Urinary tract infection viral	0		0		1	(2)	1 (1)
Cardiomyopathy	0		1	(3)	0		1 (1)
Chest wall haematoma	0		1	(3)	0		1 (1)
Engraftment syndrome	0		1	(3)	0		1 (1)
Fungal infection	0		1	(3)	0		1 (1)
Hypoxia	0		1	(3)	0		1 (1)
Pneumonia viral	0		1	(3)	0		1 (1)
Presyncope	0		1	(3)	0		1 (1)
Streptococcal sepsis	0		1	(3)	0		1 (1)
Systemic mycosis	0		1	(3)	0		1 (1)
Thrombophlebitis superficial	0		1	(3)	0		1 (1)
Upper respiratory tract infection	0		1	(3)	0		1 (1)
Venoocclusive liver disease	0		1	(3)	0		1 (1)
Pyrexia	2	(6)	0		0		1 (1)
Acute respiratory distress syndrome	1	(3)	0		0		1 (1)
Adenovirus infection	1	(3)	0		0		1 (1)
Cardiac failure	1	(3)	0		0		1 (1)
Clostridium difficile colitis	1	(3)	0		0		1 (1)
Cystitis	1	(3)	0		0		1 (1)
Drug hypersensitivity	1	(3)	0		0		1 (1)
Enterobacter infection	1	(3)	0		0		1 (1)
Hepatic lesion	1	(3)	0		0		1 (1)
Herpes zoster	1	(3)	0		0		1 (1)

Version date: October 12, 2018

Preferred Term	3.5mg/kg		4.5mg/kg		6mg/kg		Total
	(N=35)		(N=31)		(N=49)		(N=115)
	n	(%)	n	(%)	n	(%)	n(%)
Hyponatraemia	1	(3)	0		0		1 (1)
Pneumonia	1	(3)	0		0		1 (1)
Renal failure	1	(3)	0		0		1 (1)
Source: OCS Analysis Studio, AutoSafety Tool. Filters: TRTFL = "Y" (Subjects); TRTEMFL = "Y" and AESER = "Y" (Adverse Events).							

Case narratives for selected patients with SAEs are summarized below:

A 6- year-old white Hispanic/Latino male with myelodysplastic syndrome in Age Group 1 of 4.5mg/kg dose cohort underwent treatment for 21 days (11 IV and 10 POWDERMIX) and had 4 SAEs (viral pneumonia (PNA) x 2 (grade 1 on day 16 due to parainfluenza III and grade 3 due to influenza on day 97) febrile neutropenia (grade 3; day 50), and PNA (grade 3; day 80 – treated and resolved with oxacillin and clindamycin). Patient became febrile while neutropenic requiring empiric antibiotics starting on day 36 with diagnosis of SAE of febrile neutropenia on day 50.

Reviewer's comment: *As all of these AEs occurred following discontinuation of the study drug and either resolved with supportive care and/or antibiotic administration, none of them were thought to be related to the study drug.*

A 12-year-old white, Hispanic/Latino male with acute promyelocytic leukemia in Age Group 2 of 4.5mg/kg dose cohort underwent treatment for 8 days (8 IV and 0 POWDERMIX) and had 2 SAEs (grade 3 fungal infection on day 7 and grade 3 febrile neutropenia on Day 64). This patient was already undergoing therapy with dipyrone (-14 to -14;-3 to -3; -2 to -2; 1 to 1), cefepime (-14 to -7), meropenem (-3 to 15), and vancomycin (-3 to 1) for febrile neutropenia and was hospitalized on Day -15. On Day 7, the subject experienced fever without a focalized source leading to the presumptive diagnosis of invasive fungal infection. On Day 8 the subject had the non-SAE of skin nodules in the thorax and right knee and was diagnosed with non-SAE of grade 3 febrile neutropenia? Amphotericin B and linezolid were started for the suspected fungal infection with the last dose of study drug given on Day 8 with resolution of fever followed by initiation of voriconazole on Day 12 and resolution of chest nodules on Day 53 and resolution of skin nodules on Day 160.

A 14-year-old male (multiracial and Hispanic or Latino ethnicity) with acute promyelocytic leukemia in Age Group 2 of 4.5mg/kg dosing cohort underwent 7 total days of therapy and experienced grade 3 SAE of systemic mycosis (Day 11) and grade 1 pyrexia that led to discontinuation (Day 4) (see subsection of this section on significant adverse events relating to systemic fungal infections for more information).

A 16-year-old white Hispanic or Latino female experienced grade 3 vomiting as a serious adverse event on Day 21 out of 28 of study treatment duration that appears to be more related to the timing of her chemotherapy than the study drug itself. As the AE occurred during treatment with study drug, relation to the treatment cannot be definitively concluded.

Version date: October 12, 2018

A 10- year-old Asian male of non-Hispanic or Latino ethnicity with neuroblastoma and s/p stem cell transplant underwent 21 days of therapy (Age Group 2, 6mg/kg dose cohort) and experienced a SAE of grade 3 hypertension on Day 31 (s/p discontinuation of study drug); therefore, this SAE is unlikely to be related. Additionally, the patient had a preexisting condition of hypertension before entering the study which was treated with hydralazine and isradipine and resolved on Day 34 following other anti-hypertensive interventions.

A 12-year-old female (white, not Hispanic or Latino) with metastatic Ewing's sarcoma, myelodysplastic syndrome, Age Group 2 in 6mg/kg dosing cohort underwent 28 days of therapy and experienced two SAEs (parainfluenza virus grade 3 on Day 27 and viral UTI grade 3 on Day 29) unrelated to study drug.

A 15-year-old white, not Hispanic or Latino, male with Hodgkin's disease s/p stem cell transplant in Age Group 2 in the 3.5mg/kg dose cohort underwent 28 days of therapy and experienced one SAE on Day 32 of herpes zoster grade 3 following discontinuation of study drug and while patient was undergoing significant immunosuppressive therapy with skin lesions that resolved following acyclovir administration by Day 44.

An 11- year- old white female (not Hispanic or Latino) with ALL s/p stem cell transplant in Age Group 2, 3.5mg/kg dosing cohort, underwent 28 days of therapy and experienced grade 1 SAE of pyrexia on dDay 27. Fever was reported at home, and the patient was afebrile without treatment upon admission to hospital. Remained afebrile without any antibiotics or antipyretics administered, and no action taken. The fever unlikely related to study drug.

A 9- year -old white, not Hispanic or Latino, female with myelodysplastic syndrome s/p stem cell transplant underwent 12 days of therapy (6mg/kg , Age Group 2) and experienced a SAE of transplant rejection grade 3 occurring on Day 11 that led to discontinuation of study drug.

A 3-year-old white male (not Hispanic or Latino) with aplastic anemia in Age Group 1 (3.5mg/kg dose cohort) underwent 23 days of therapy with grade 3 SAE of hyponatremia occurring on Day 26, therefore unlikely related to study drug.

A 4- year- old white, not Hispanic or Latino, male (Age Group 1, 4.5mg/kg dose cohort) with neuroblastoma, s/p stem cell transplant (autologous PBSCT on day 3) who underwent central venous catheter placement and 20 days total of study treatment experienced a SAE of grade 3 veno-occlusive liver disease on Day 30. On Day 38, event resolved following multiple therapies; it was determine to be unlikely related to study drug.

A 16 -year- old white female (not Hispanic or Latino) in Age Group 2 of 3.5mg/kg dosing cohort with Ewing's sarcoma (recurrent) s/p stem cell transplant developed a SAE of *C. difficile* colitis (grade 3 occurring on Day 10), febrile neutropenia grade 3 (occurring on Day 13), and cystitis grade 3 occurring on Day 30 who underwent 26 days of study drug treatment.

An 11- year- old white, not Hispanic or Latino, female with recurrent Ewing's sarcoma s/p stem cell

Version date: October 12, 2018

transplant in Age Group 2 of 3.5mg/kg dose cohort underwent 11 days of therapy and experienced a grade 3 SAE of hepatic lesion on Day 11 that led to discontinuation of study drug.

A 4 -year- old white, not Hispanic or Latino, male with aplastic anemia and a liver disorder (unspecified), age group 1 of 6mg/kg dose cohort who underwent 20 days of treatment and experienced grade 4 SAE of febrile neutropenia (day 14), grade 4 posterior reversible encephalopathy syndrome on day 20 that led to discontinuation of study drug.

A 3-year-old white, not Hispanic or Latino male with acute leukemia (unspecified) and history of emesis; age group 1 of 6mg/kg dose cohort who underwent 13 days of therapy experienced SAE of vomiting grade 3 on day 26; therefore, the AE is unlikely related to study drug.

A 10-year-old white, not Hispanic or Latino male in Age Group 2 of 6mg/kg dose cohort with acute leukemia who underwent 28 days of therapy experienced a grade 3 SAE febrile neutropenia on Day 36; therefore, the SAE is unlikely related to study drug.

Dropouts and/or Discontinuations Due to Adverse Effects

Error! Reference source not found. summarizes the TEAEs leading to study drug discontinuation by age and dose across all cohorts.

Table 10-5 TEAEs leading to Study Drug Discontinuation

	Treatment 3.5 mg/kg		Treatment 4.5 mg/kg		Treatment 6 mg/kg		Total	
	2-<7 (N=14)	7-17 (N=21)	2-<7 (N=15)	7-17 (N=16)	2-<7 (N=19)	7-17 (N=30)	2-<7 (N=48)	7-17 (N=67)
Drug withdrawn	3 (21)	3 (14)	0	2 (13)	4 (21)	6 (20)	7 (15)	11 (16)
Pyrexia	0	1 (5)	0	1 (6.)	1 (5)	0	1 (2)	2 (3)
Veno-occlusive disease	1 (7)	0	0	0	0	1 (3)	1 (2)	1 (2)
Abdominal pain	0	0	0	0	1 (5)	0	1 (2.1)	0
Acute kidney injury	0	0	0	0	0	1 (3)	0	1 (2)
Acute myeloid leukemia	0	0	0	0	0	1 (3)	0	1 (2)
Acute respiratory distress syndrome	0	1 (5)	0	0	0	0	0	1 (2)
Alanine aminotransferase increased	0	0	0	0	0	1 (3)	0	1 (2)
Aspartate aminotransferase increased	0	0	0	0	0	1 (3)	0	1 (2)
Blood bilirubin increased	1 (7)	0	0	0	0	0	1 (2)	0
Drug hypersensitivity	1 (7)	0	0	0	0	0	1 (2)	0
Electrocardiogram QT prolonged	0	0	0	0	0	1 (3)	0	1 (2)
Epistaxis	1 (7)	0	0	0	0	0	1 (2)	0
Fungal infection	0	0	0	1 (6)	0	0	0	1 (2)

Version date: October 12, 2018

	Treatment 3.5 mg/kg		Treatment 4.5 mg/kg		Treatment 6 mg/kg		Total	
	2-<7 (N=14)	7-17 (N=21)	2-<7 (N=15)	7-17 (N=16)	2-<7 (N=19)	7-17 (N=30)	2-<7 (N=48)	7-17 (N=67)
Hepatic lesion	0	1 (5)	0	0	0	0	0	1 (2)
Posterior reversible encephalopathy syndrome	0	0	0	0	1 (5)	0	1 (2)	0
Rash	0	0	0	0	1 (5)	0	1 (2)	0
Transplant rejection	0	0	0	0	0	1 (3)	0	1 (2)

Source: Reviewer's Analysis (Analysis Studio)

Table 11-6 below includes TEAEs by pooled (group query) and preferred terms leading to drug discontinuation for total 6mg/kg dose cohort by age.

Table 10-6 Treatment Emergent Adverse by Age Group Leading to Study Drug Discontinuation (Pooled Analysis, for 6 mg/kg Dose Cohort)

	6 mg/kg: Age Group 1 (2-<7 years old) n=20 (%)	6 mg/kg: Age Group 2 (7-17 years old) n=29 (%)	Total Study population (3 dose cohorts) n=115 (%)
Subjects with at least 1 TEAE leading to drug discontinuation - count subjects and % with data	4 (20.0%)	6 (20.7%)	18 (15.7%)
*Fever	1 (5.0%)	0	3 (2.6%)
Pyrexia	1 (5.0%)	0	3 (2.6%)
Veno-occlusive disease	0	1 (3.4%)	2 (1.7%)
Veno-occlusive disease	0	1 (3.4%)	2 (1.7%)
Acute respiratory distress syndrome	0	0	1 (0.9%)
Acute respiratory distress syndrome	0	0	1 (0.9%)
Hepatic lesion	0	0	1 (0.9%)
Hepatic lesion	0	0	1 (0.9%)
Epistaxis	0	0	1 (0.9%)
Epistaxis	0	0	1 (0.9%)
*Fungal infection	0	0	1 (0.9%)
Fungal infection	0	0	1 (0.9%)
*Abdominal pain	1 (5.0%)	0	1 (0.9%)
Abdominal pain	1 (5.0%)	0	1 (0.9%)
*Hyperbilirubinaemia	0	0	1 (0.9%)
Blood bilirubin increased	0	0	1 (0.9%)
*Rash	1 (5.0%)	0	1 (0.9%)
Rash	1 (5.0%)	0	1 (0.9%)
Posterior reversible encephalopathy syndrome	1 (5.0%)	0	1 (0.9%)
Posterior reversible encephalopathy syndrome	1 (5.0%)	0	1 (0.9%)
*Acute kidney injury	0	1 (3.4%)	1 (0.9%)
Acute kidney injury	0	1 (3.4%)	1 (0.9%)
*Elevated LFTs	0	1 (3.4%)	1 (0.9%)
Alanine aminotransferase increased	0	1 (3.4%)	1 (0.9%)
Aspartate aminotransferase increased	0	1 (3.4%)	1 (0.9%)
*Graft failure	0	1 (3.4%)	1 (0.9%)
Transplant rejection	0	1 (3.4%)	1 (0.9%)
Acute myeloid leukaemia	0	1 (3.4%)	1 (0.9%)

Version date: October 12, 2018

NDA Multi-disciplinary Review and Evaluation, sNDA 205596, 205053, 214770
 NOXAFIL® (posaconazole) injection, delayed release tablet, PowderMix
 For prophylaxis of invasive fungal infections in pediatric patients 2 years of age and older
 For treatment of invasive aspergillosis in adults and pediatric patients 13 years and older

	6 mg/kg: Age Group 1 (2-<7 years old) n=20 (%)	6 mg/kg: Age Group 2 (7-17 years old) n=29 (%)	Total Study population (3 dose cohorts) n=115 (%)
Acute myeloid leukaemia	0	1 (3.4%)	1 (0.9%)
Electrocardiogram QT prolonged	0	1 (3.4%)	1 (0.9%)
Electrocardiogram QT prolonged	0	1 (3.4%)	1 (0.9%)
*Drug hypersensitivity	0	0	1 (0.9%)
Drug hypersensitivity	0	0	1 (0.9%)

Source: Reviewer's analysis (JReview)

Eighteen subjects (16%) experienced adverse events leading to discontinuations. The most common reason for discontinuation being pyrexia in 3 subjects followed by VOD in 2 subjects. One of these was a subject in age group 2 of 6mg/kg cohort who experienced QT prolongation from 386 to 430 ms on day 14 with resolution 9 days later. This patient had been diagnosed with the AE of endocarditis on day 4 with concurrent AEs of hypocalcemia, hypokalemia, and hypomagnesemia. His steady-state Cavg POS concentration was 3060ng/mL while on IV POS.

Reviewer's Comment: *As the patient's QT prolongation occurred while the patient was on the study drug with a Cavg exceeding the specified max of 2500ng/mL, we cannot exclude drug related causality in a setting of concurrent metabolic electrolyte abnormalities.*

Another subject in the 6mg/kg cohort from age group 2 experienced the adverse events of both increased ALT and increased AST, but this patient had a history of abnormal liver function tests with elevated ALT and AST at baseline that increased to Grade 3 on day 2 of IV POS, requiring discontinuation on the same day, and resolved by day 18. There is no POS Cavg value for this subject since the subject discontinued the study treatment prior to the steady-state PK sampling visit.

Reviewer's Comment: *Although this patient had abnormal baseline values of LFTs, the rapid rise in these levels while on the study drug cannot be excluded particularly without knowing the Cavg value of POS in this patient.*

Another patient of the 3.5mg/kg Age Group 1 cohort experienced epistaxis on Day 2 of IV POS (which was discontinued on day 8) and resolved by day 11 who had a steady-state Cavg POS concentration of 449 ng/mL while on IV POS.

A 3 year old Asian (not Hispanic or Latino) male with thalassemia, post stem-cell transplant, who was part of 3.5mg/kg and age group 1 cohorts underwent 8 days of total therapy (all IV) and experienced a grade 3 drug hypersensitivity on day 4 of treatment determined to be a SAE as well as epistaxis on day 2. As both AEs were thought to be related to the study drug by the investigator, these adverse events led to discontinuation of the study drug on day 8.

Version date: October 12, 2018

NDA Multi-disciplinary Review and Evaluation, sNDA 205596, 205053, 214770
 NOXAFIL® (posaconazole) injection, delayed release tablet, PowderMix
 For prophylaxis of invasive fungal infections in pediatric patients 2 years of age and older
 For treatment of invasive aspergillosis in adults and pediatric patients 13 years and older

Reviewer's Comment: Given the timing of the onset of the AE upon initiation of the study drug and positive dechallenge, a drug-related causality cannot be completely excluded.

The adverse event of rash occurred in a subject in the 6mg/kg Age Group 1 dose cohort which began on Day 1 of the study treatment (which was discontinued on Day 12). The adverse event resolved by Day 14 and the patient's steady-state Cavg POS concentration was 1760 ng/mL while on IV POS.

Reviewer's Comment: The rash appeared on Day 1 of the study drug administration and resolved only 2 days following discontinuation of the drug (Day 14). Positive dechallenge suggests possible relationship to POS.

Another patient in the 3.5mg/kg age group 1 dosing cohort had an increase in total bilirubin from 6.8mmol micromol/L on Day 1 to 63 micromol/L (Grade 2) on Day 3. Patient was transfused RBCs from day 2 to 3 and on day 6, (prior to study drug discontinuation on Day 7), the total bilirubin trended down to 42.75 micromol/L.

Reviewer's Comment: Given that the total serum bilirubin decreased to 41.75 micromol/L on Day 6 (from its peak elevation to Grade 2 toxicity of 63mmol/L on Day 3) prior to study drug discontinuation, the drug related causality for Tbili elevation is less likely. Additionally, the patient was transfused RBCs from Day 2 to 3 which is likely to have contributed at least in part to the rise in total bilirubin.

Significant Adverse Events

Error! Reference source not found. summarizes TEAEs by maximum severity/toxicity grading in the three cohorts (3.5mg/kg, 4.5mg/kg, 6mg/kg) and in a descending order in the 6mg/kg cohort .

Pruritis, hypokalemia, AST and ALT elevations, thrombocytopenia, hypophosphatemia, hypoalbuminemia, (and oropharyngeal pain, myalgia, and dry eye) show increasing frequency in overall toxicity and in grade 3 to 5 specific toxicity with increasing dose.

Table 10-7 Summary of TEAEs by Maximum Severity-Toxicity by Dose Cohort occurring in >5% of Study Subjects

Preferred Term	3.5mg/kg		4.5mg/kg		6mg/kg							
	(N=35)		(N=31)		(N=49)							
	Grade 1 to 5		Grade 3 to 5		Grade 1 to 5		Grade 3 to 5					
	n	(%)	n	(%)	n	(%)	n	(%)				
Pyrexia	18	(51.4)	1	(2.9)	16	(51.6)	0		16	(32.7)	1	(2.0)
Febrile neutropenia	6	(17.1)	4	(11.4)	4	(12.9)	3	(9.7)	15	(30.6)	11	(22.4)
Vomiting	10	(28.6)	0		8	(25.8)	0		12	(24.5)	2	(4.1)
Mucosal inflammation	12	(34.3)	2	(5.7)	9	(29.0)	5	(16.1)	11	(22.4)	3	(6.1)
Pruritus	1	(2.9)	0		6	(19.4)	0		11	(22.4)	0	
Hypokalemia	2	(5.7)	0		4	(12.9)	1	(3.2)	10	(20.4)	5	(10.2)
Hypertension	7	(20.0)	0		3	(9.7)	0		10	(20.4)	2	(4.1)
Stomatitis	2	(5.7)	1	(2.9)	1	(3.2)	1	(3.2)	10	(20.4)	7	(14.3)
Diarrhea	7	(20.0)	0		9	(29.0)	1	(3.2)	9	(18.4)	1	(2.0)
Nausea	5	(14.3)	1	(2.9)	4	(12.9)	0		9	(18.4)	0	

Version date: October 12, 2018

Preferred Term	3.5mg/kg		4.5mg/kg		6mg/kg	
	(N=35)		(N=31)		(N=49)	
	Grade 1 to 5	Grade 3 to 5	Grade 1 to 5	Grade 3 to 5	Grade 1 to 5	Grade 3 to 5
	n (%)	n (%)	n (%)	n (%)	n (%)	n (%)
Abdominal pain	4 (11.4)	0	8 (25.8)	1 (3.2)	8 (16.3)	1 (2.0)
Rash	6 (17.1)	1 (2.9)	5 (16.1)	0 (0.0)	7 (14.3)	0
Decreased appetite	6 (17.1)	2 (5.7)	4 (12.9)	1 (3.2)	7 (14.3)	2 (4.1)
Headache	5 (14.3)	0	5 (16.1)	0	6 (12.2)	0
Alanine aminotransferase increased	1 (2.9)	1 (2.9)	1 (3.2)	0	6 (12.2)	2 (4.1)
Aspartate aminotransferase increased	1 (2.9)	0	2 (6.5)	0	5 (10.2)	2 (4.1)
Epistaxis	3 (8.6)	1 (2.9)	6 (19.4)	0	4 (8.2)	0
Anemia	2 (5.7)	2 (5.7)	4 (12.9)	3 (9.7)	4 (8.2)	2 (4.1)
Constipation	5 (14.3)	0	3 (9.7)	2 (6.5)	4 (8.2)	0
Hypomagnesaemia	3 (8.6)	0	3 (9.7)	0	4 (8.2)	0
Back pain	1 (2.9)	0	3 (9.7)	0	4 (8.2)	0
Abdominal pain upper	3 (8.6)	0	2 (6.5)	0	4 (8.2)	2 (4.1)
Erythema	1 (2.9)	0	2 (6.5)	0	4 (8.2)	0
Hypophosphatemia	0 (0.0)	0	1 (3.2)	0	4 (8.2)	0
Drug hypersensitivity	1 (2.9)	1 (2.9)	0 (0.0)	0	4 (8.2)	1 (2.0)
Hypoalbuminemia	0 (0.0)	0	0 (0.0)	0	4 (8.2)	0
Cough	2 (5.7)	0	5 (16.1)	0	3 (6.1)	0
Cytomegalovirus infection	0 (0.0)	0	4 (12.9)	0	3 (6.1)	1 (2.0)
Thrombocytopenia	2 (5.7)	1 (2.9)	2 (6.5)	1 (3.2)	3 (6.1)	2 (4.1)
Hypotension	0 (0.0)	0	2 (6.5)	0	3 (6.1)	0
Epstein-Barr virus infection	2 (5.7)	0	1 (3.2)	0	3 (6.1)	1 (2.0)
Graft versus host disease in skin	2 (5.7)	2 (5.7)	1 (3.2)	0	3 (6.1)	0
Platelet count decreased	1 (2.9)	1 (2.9)	1 (3.2)	1 (3.2)	3 (6.1)	3 (6.1)
Oropharyngeal pain	1 (2.9)	0	1 (3.2)	0	3 (6.1)	0
Myalgia	1 (2.9)	0	1 (3.2)	0	3 (6.1)	0
Dry eye	1 (2.9)	0	1 (3.2)	0	3 (6.1)	0
Edema peripheral	1 (2.9)	0	0 (0.0)	0	3 (6.1)	0

Source: Reviewer's Analysis (Analysis Studio)

Treatment Emergent Adverse Events and Adverse Reactions

The most common adverse events overall were fever, mucositis, rash, vomiting, abdominal pain, musculoskeletal pain, diarrhea, elevated LFTs, hypertension, pruritis, decreased appetite, hypokalemia, nausea, headache, GVHD, epistaxis, constipation, and thrombocytopenia (pooled PTs). The most common TEAE by SOC were GI-related. There were two adverse events consistent with possible or probable IFI reported in 2 subjects (1.7%) during the study period. Both AEs occurred in Age Group 2 in the 4.5 mg/kg dose cohort one of whom experienced systemic mycosis starting on Day 11 as day fever without a clear source and follow up CT scans showing evidence of splenic and lung lesions likely of fungal etiology. POS IV had been discontinued on Day 7 due to pyrexia and investigator's decision to escalate therapy to include amphotericin B. A follow-up CT chest showed densities in spleen and lung suggestive of disseminated fungal infection and the patient was started on voriconazole. Patient continued on outpatient voriconazole and on Day 94 systemic mycosis resolved and outpatient voriconazole stopped.

Version date: October 12, 2018

The other subject's fungal infection started on Day 7 as fever and skin nodules after which the subject was started on amphotericin B and POS IV was discontinued on day 8. Following addition of voriconazole and continued chemotherapy and outpatient voriconazole with complete resolution on Day 160. Both subjects had POS Cavg concentrations within the target therapeutic range (1190ng/mL and 1180ng/mL) compared to the mean of Cavg 1240ng/mL for this age group. Both adverse events were resolved by the end of the study follow-up period.

Error! Reference source not found. summarizes the most common TEAE by pooled (group query) term and dose and age cohort descending by the total down to >5%. Highlighted are the remarkable labs in the 6mg/kg dosing cohort, all of which are higher in the older age group other than anemia.

Table 10-8 TEAEs by pooled Preferred Term and Dose and Age Cohort in > 5% Study Subjects

TEAEs	Treatment 3.5 mg/kg:		Treatment 4.5 mg/kg:		Treatment 6 mg/kg		Totals N=115 n (%)
	Group 1 (2-<7 y) N=14 n (%)	Group 2 (7-17 y) N=21 n (%)	Group 1 (2- <7 y) N=15 n (%)	Group 2 (7- 17 y) N=16 n (%)	Group 1 (2- <7 y) N=20 n (%)	Group 2 (7- 17 y) N=29 n (%)	
Subjects with at least 1 TEAE	13 (92.9%)	21 (100.0%)	15 (100.0%)	16 (100.0%)	19 (95.0%)	29 (100.0%)	113 (98.3%)
*Fever	10 (71.4%)	13 (61.9%)	6 (40.0%)	12 (75.0%)	12 (60.0%)	14 (48.3%)	67 (58.3%)
*Mucositis	3 (21.4%)	11 (52.4%)	6 (40.0%)	5 (31.3%)	10 (50.0%)	14 (48.3%)	49 (42.6%)
*Rash	4 (28.6%)	7 (33.3%)	5 (33.3%)	5 (31.3%)	7 (35.0%)	5 (17.2%)	33 (28.7%)
Vomiting	4 (28.6%)	6 (28.6%)	2 (13.3%)	6 (37.5%)	6 (30.0%)	6 (20.7%)	30 (26.1%)
*Abdominal pain	3 (21.4%)	4 (19.0%)	4 (26.7%)	6 (37.5%)	5 (25.0%)	7 (24.1%)	29 (25.2%)
*Musculoskeletal pain	2 (14.3%)	6 (28.6%)	3 (20.0%)	7 (43.8%)	2 (10.0%)	6 (20.7%)	26 (22.6%)
Diarrhea	5 (35.7%)	2 (9.5%)	5 (33.3%)	4 (25.0%)	5 (25.0%)	4 (13.8%)	25 (21.7%)
Hypertension	5 (35.7%)	2 (9.5%)	2 (13.3%)	1 (6.3%)	6 (30.0%)	4 (13.8%)	20 (17.4%)
*Hypokalemia	3 (21.4%)	2 (9.5%)	1 (6.7%)	4 (25.0%)	3 (15.0%)	7 (24.1%)	20 (17.4%)
*Pruritus	0 (0.0%)	1 (4.8%)	1 (6.7%)	5 (31.3%)	5 (25.0%)	8 (27.6%)	20 (17.4%)
*Decrease appetite	3 (21.4%)	4 (19.0%)	4 (26.7%)	1 (6.3%)	4 (20.0%)	4 (13.8%)	20 (17.4%)
Nausea	1 (7.1%)	4 (19.0%)	1 (6.7%)	3 (18.8%)	2 (10.0%)	7 (24.1%)	18 (15.7%)
Headache	1 (7.1%)	4 (19.0%)	0 (0.0%)	5 (31.3%)	1 (5.0%)	5 (17.2%)	16 (13.9%)
*Graft versus host disease	2 (14.3%)	4 (19.0%)	0 (0.0%)	2 (12.5%)	2 (10.0%)	4 (13.8%)	14 (12.2%)
*Constipation	3 (21.4%)	2 (9.5%)	2 (13.3%)	1 (6.3%)	0 (0.0%)	5 (17.2%)	13 (11.3%)
Epistaxis	2 (14.3%)	1 (4.8%)	1 (6.7%)	5 (31.3%)	1 (5.0%)	3 (10.3%)	13 (11.3%)
*Thrombocytopenia	1 (7.1%)	2 (9.5%)	0 (0.0%)	3 (18.8%)	2 (10.0%)	4 (13.8%)	12 (10.4%)
*Hypomagnesaemia	2 (14.3%)	1 (4.8%)	2 (13.3%)	1 (6.3%)	1 (5.0%)	4 (13.8%)	11 (9.6%)
Anemia	1 (7.1%)	1 (4.8%)	1 (6.7%)	3 (18.8%)	2 (10.0%)	2 (6.9%)	10 (8.7%)
*Oxygen saturation decreased	1 (7.1%)	2 (9.5%)	1 (6.7%)	3 (18.8%)	1 (5.0%)	2 (6.9%)	10 (8.7%)
*Erythema	1 (7.1%)	1 (4.8%)	1 (6.7%)	1 (6.3%)	4 (20.0%)	2 (6.9%)	10 (8.7%)
Cough	2 (14.3%)	0 (0.0%)	4 (26.7%)	1 (6.3%)	0 (0.0%)	3 (10.3%)	10 (8.7%)
*Transfusion reaction	1 (7.1%)	1 (4.8%)	0 (0.0%)	3 (18.8%)	2 (10.0%)	1 (3.4%)	8 (7.0%)

Version date: October 12, 2018

TEAEs	Treatment 3.5 mg/kg:		Treatment 4.5 mg/kg:		Treatment 6 mg/kg		Totals N=115 n (%)
	Group 1 (2-<7 y) N=14 n (%)	Group 2 (7-17 y) N=21 n (%)	Group 1 (2- <7 y) N=15 n (%)	Group 2 (7- 17 y) N=16 n (%)	Group 1 (2- <7 y) N=20 n (%)	Group 2 (7- 17 y) N=29 n (%)	
Subjects with at least 1 TEAE	13 (92.9%)	21 (100.0%)	15 (100.0%)	16 (100.0%)	19 (95.0%)	29 (100.0%)	113 (98.3%)
Alanine aminotransferase increased	0 (0.0%)	1 (4.8%)	1 (6.7%)	0 (0.0%)	1 (5.0%)	5 (17.2%)	8 (7.0%)
*Edema	0 (0.0%)	2 (9.5%)	1 (6.7%)	0 (0.0%)	2 (10.0%)	3 (10.3%)	8 (7.0%)
Aspartate aminotransferase increased	0 (0.0%)	1 (4.8%)	1 (6.7%)	1 (6.3%)	0 (0.0%)	5 (17.2%)	8 (7.0%)
*Edema facial	2 (14.3%)	1 (4.8%)	0 (0.0%)	0 (0.0%)	0 (0.0%)	4 (13.8%)	7 (6.1%)
*Drug hypersensitivity	1 (7.1%)	0 (0.0%)	0 (0.0%)	0 (0.0%)	3 (15.0%)	3 (10.3%)	7 (6.1%)
Cytomegalovirus infection	0 (0.0%)	0 (0.0%)	3 (20.0%)	1 (6.3%)	1 (5.0%)	2 (6.9%)	7 (6.1%)
Transaminases increased	2 (14.3%)	1 (4.8%)	1 (6.7%)	3 (18.8%)	0 (0.0%)	0 (0.0%)	7 (6.1%)
*Oropharyngeal pain	0 (0.0%)	3 (14.3%)	1 (6.7%)	0 (0.0%)	0 (0.0%)	3 (10.3%)	7 (6.1%)
*Neutropenia	0 (0.0%)	2 (9.5%)	1 (6.7%)	0 (0.0%)	0 (0.0%)	3 (10.3%)	6 (5.2%)
Epstein-Barr virus infection	1 (7.1%)	1 (4.8%)	1 (6.7%)	0 (0.0%)	1 (5.0%)	2 (6.9%)	6 (5.2%)
*Skin lesion	3 (21.4%)	2 (9.5%)	0 (0.0%)	0 (0.0%)	1 (5.0%)	0 (0.0%)	6 (5.2%)
*Hyperbilirubinemia	1 (7.1%)	1 (4.8%)	1 (6.7%)	3 (18.8%)	0 (0.0%)	0 (0.0%)	6 (5.2%)
Tachycardia	1 (7.1%)	2 (9.5%)	1 (6.7%)	0 (0.0%)	1 (5.0%)	1 (3.4%)	6 (5.2%)
Veno-occlusive disease	3 (21.4%)	0 (0.0%)	1 (6.7%)	0 (0.0%)	0 (0.0%)	2 (6.9%)	6 (5.2%)
*Upper respiratory tract infection	0 (0.0%)	0 (0.0%)	3 (20.0%)	0 (0.0%)	1 (5.0%)	2 (6.9%)	6 (5.2%)

Source: Reviewer's analyses (JReview) custom group query
 pooled terms marked with *

Error! Reference source not found. summarizes the most common TEAE by pooled preferred terms and dose cohort by descending order in the 6mg/kg group.

The most frequently reported adverse events (>20%) in the proposed 6mg/kg dose for marketing included fever and GI symptoms as in adults, but varied from adults in that there were significant numbers of mucocutaneous AE including mucositis, pruritis, and rash (49%, 26.5%, and 26.5 respectively), followed by reported hypokalemia (20.4%) and hypertension (20.4%). **Error! Reference source not found.** presents TEAEs (>10%) by pooling of preferred terms in descending order in the 6mg/kg dose cohort. Given the small sample size, pooled terms were created to group similar TEAEs to increase the precision of safety signal detection.

The most common TEAEs leading to discontinuation of posaconazole in the prophylaxis studies in pediatrics including all dose/age cohorts were fever (2.6%) followed by venoocclusive disease (1.7%) varying from adult studies in which the most common adverse events leading to discontinuation were associated with GI disorders (nausea 2%, vomiting, 2%, and hepatic enzymes increased 2%)

Version date: October 12, 2018

Table 10-9 TEAEs by Pooled Preferred Terms in 6mg/kg Dose Cohort occurring in > 5% of Study Subjects

	6 mg/kg Dose Cohort		All Dose Cohorts n=115 (%)
	n=49 (%)		
Subjects with at least 1 TEAE	48 (98.0%)		113 (98.3%)
*Fever	26 (53.1%)		67 (58.3%)
*Mucositis	24 (49.0%)		49 (42.6%)
*Pruritus	13 (26.5%)		20 (17.4%)
*Rash	13 (26.5%)		34 (29.6%)
Vomiting	12 (24.5%)		30 (26.1%)
*Abdominal pain	12 (24.5%)		29 (25.2%)
*Hypokalemia	10 (20.4%)		20 (17.4%)
Hypertension	10 (20.4%)		20 (17.4%)
Nausea	9 (18.4%)		18 (15.7%)
Diarrhea	9 (18.4%)		25 (21.7%)
*Decrease appetite	8 (16.3%)		20 (17.4%)
*Musculoskeletal pain	8 (16.3%)		26 (22.6%)
*Edema	7 (14.3%)		11 (9.6%)
Headache	6 (12.2%)		16 (13.9%)
*Elevated LFTs	6 (12.2%)		16 (13.9%)
*Erythema	6 (12.2%)		10 (8.7%)
*Thrombocytopenia	6 (12.2%)		12 (10.4%)
*Drug hypersensitivity	6 (12.2%)		7 (6.1%)
*Hypomagnesemia	6 (12.2%)		12 (10.4%)
*Graft versus host disease	6 (12.2%)		14 (12.2%)
*Hypoalbuminemia	5 (10.2%)		6 (5.2%)
*Constipation	5 (10.2%)		13 (11.3%)

Source: Reviewer’s analyses (JReview) custom group query

Pooled terms are marked with *.

The Applicant requested to present the adverse reaction profile by the preferred term only (Table 11-10) to be consistent with the presentation for other clinical trials in the labeling.

Table 10-10 TEAEs by Preferred Term Occurring in > 5% of Study Subjects, P097

Treatment Emergent Adverse Events	3.5 mg/kg N=35 n (%)	4.5 mg/kg (N=31) n (%)	6 mg/kg (N=49) n (%)	All Dose Cohorts (N=115) n (%)
Pyrexia	18 (51)	16 (52)	16 (33)	50 (43)
Febrile neutropenia	6 (17)	4 (13)	15 (31)	25 (22)
Vomiting	10 (29)	8 (26)	12 (24)	30 (26)
Mucosal inflammation	12 (34)	9 (29)	11 (22)	32 (28)
Pruritus	1 (3)	6 (19)	11 (22)	18 (16)
Hypertension	7 (20)	3 (10)	10 (20)	20 (17)
Hypokalemia	2 (6)	4 (13)	10 (20)	16 (14)
Stomatitis	2 (6)	1 (3)	10 (20)	13 (11)

Version date: October 12, 2018

Treatment Emergent Adverse Events	3.5 mg/kg N=35 n (%)	4.5 mg/kg (N=31) n (%)	6 mg/kg (N=49) n (%)	All Dose Cohorts (N=115) n (%)
Diarrhea	7 (20)	9 (29)	9 (18)	25 (22)
Nausea	5 (14)	4 (13)	9 (18)	18 (16)
Abdominal pain	4 (11)	8 (26)	8 (16)	20 (17)
Decreased appetite	6 (17)	4 (13)	7 (14)	17 (15)
Rash	6 (17)	5 (16)	7 (14)	18 (16)
Alanine aminotransferase increased	1 (3)	1 (3)	6 (12)	8 (7)
Headache	5 (14)	5 (16)	6 (12)	16 (14)
Aspartate aminotransferase increased	1 (3)	2 (6)	5 (10)	8 (7)
Anemia	2 (6)	4 (13)	4 (8)	10 (9)
Constipation	5 (14)	3 (10)	4 (8)	12 (10)
Epistaxis	3 (9)	6 (19)	4 (8)	13 (11)
Cough	2 (6)	5 (16)	3 (6)	10 (9)
Cytomegalovirus infection	0	4 (13)	3 (6)	7 (6)
Graft versus host disease	4 (11)	1 (3)	1 (2)	6 (5)
Pain in extremity	3 (9)	4 (13)	1 (2)	8 (7)
Transaminases increased	3 (9)	4 (13)	0	7 (6)

Source: Reviewer's analyses; OCS Analysis Studio, Custom Table Tool.
Columns - Dataset: Demographics; Filter: ACTARM = 'Posaconazole', TRTFL = 'Y'.
Table Section 1 - Dataset: Adverse Events; Filter: TRTEMFL = 'Y'; Percent Threshold: >= 10%.

A 3-year-old Asian male (USUBJID (b) (6)), Age Group 1) of the 3.5mg/kg cohort, experienced a SAE of grade 3 drug hypersensitivity on Day 4 of POS IV therapy resulting in subsequent drug discontinuation on Day 8 and the event resolved after 7 days. This subject also experienced grade 3 epistaxis, a non-SAE on Day 2 that lasted 9 days and was an additional reason behind the study drug discontinuation. In this patient, the steady state Cavg concentration while on POS IV was 449ng/mL.

Laboratory Findings

Hepatic

ALT/AST: Approximately 50% of patients have experienced shifts in ALT and AST postbaseline; these did not appear to be dose related.

As displayed in Tables 11-11 and 11-12 below shifts from grade 0-2 to grade ≥3 postbaseline occurred 3/49 (6%) and 2/49 (4%) pediatric patients in the 6 mg/kg dose group for ALT and AST, respectively compared to 6-17 % and 3-4% adults receiving POS oral suspension in IFI prophylaxis trials.

Version date: October 12, 2018

Table 10-11 Change from Baseline, ALT

Baseline ALT grade	Worst ALT Grade Postbaseline	Treatment 3.5 mg/kg:		Treatment 4.5 mg/kg:		Treatment 6 mg/kg	
		Group 1 (2-<7 y) N=14 n (%)	Group 2 (7-17 y) N=21 n (%)	Group 1 (2-<7 y) N=15 n (%)	Group 2 (7-17 y) N=16 n (%)	Group 1 (2-<7 y) N=20 n (%)	Group 2 (7-17 y) N=29 n (%)
Grade 0 >=LLN to <=ULN	Grade 1 >ULN to <=3x ULN	6 (43)	5 (24)	5 (33)	5 (31)	3 (15)	6 (21)
	Grade 2 >3x ULN to <=5x ULN	0	2 (10)	1 (7)	1 (6)	0	3 (10)
	Grade 3 >5x ULN to <=20x ULN	1 (7)	1 (5)	1 (7)	0	0	0
Grade 1 >ULN to <=3x ULN	Grade 2 >3x ULN to <=5x ULN	0	0	0	0	2 (10)	1 (3)
	Grade 3 >5x ULN to <=20x ULN	0	3 (14)	1 (7)	1 (6)	0	3 (10)
Grade 2 >3x ULN to <=5x ULN		0	1 (5)	1 (7)	1 (6)	0	0 (0)
	Subjects(filtered)	7 (50)	12 (57)	9 (60)	8 (50)	5 (25)	13 (45)
	1stCollItemSubjects	14 (100)	21 (100)	15 (100)	16 (100)	20 (100)	29 (100)

Source: Reviewer's analyses (JReview)

Table 10-12 Change from Baseline, AST

Baseline AST grade	Worst AST Grade Post baseline	Treatment 3.5 mg/kg:		Treatment 4.5 mg/kg:		Treatment 6 mg/kg	
		Group 1 (2-<7 y) N=14 n (%)	Group 2 (7-17 y) N=21 n (%)	Group 1 (2-<7 y) N=15 n (%)	Group 2 (7-17 y) N=16 n (%)	Group 1 (2-<7 y) N=20 n (%)	Group 2 (7-17 y) N=29 n (%)
Grade 0 >=LLN to <=ULN	Grade 1 >ULN to <=3x ULN	3 (21)	8 (38)	7 (47)	3 (19)	3 (15)	9 (31)
	Grade 2 >3x ULN to <=5x ULN	1 (7)	2 (10)	1 (7)	1 (6)	0 (0)	1 (3)
	Grade 3 >5x ULN to <=20x ULN	0 (0)	0 (0)	2 (13)	1 (6)	0 (0)	0 (0)
Grade 1 >ULN to <=3x ULN	Grade 2 >3x ULN to <=5x ULN	1 (7)	0 (0)	1 (7)	1 (6)	0 (0)	2 (7)
	Grade 3 >5x ULN to <=20x ULN	0 (0)	0 (0)	0 (0)	0 (0)	0 (0)	2 (7)
	Subjects(filtered)	5 (36)	10 (48)	11 (73)	6 (38)	3 (15)	14 (48)
	1stCollItemSubjects	14 (100)	21 (100)	15 (100)	16 (100)	20 (100)	29 (100)

Source: Reviewer's analyses (JReview)

Total bilirubin: Elevations of total bilirubin levels postbaseline does not appear to be dose related.

Version date: October 12, 2018

Table 10-13 Change from Baseline, Total Bilirubin

Baseline Total Bilirubin - Grade Category	Worst Total Bilirubin - Grade Post baseline	Treatment 3.5 mg/kg:		Treatment 4.5 mg/kg:		Treatment 6 mg/kg	
		Group 1 (2-<7 y) N=14 n (%)	Group 2 (7-17 y) N=21 n (%)	Group 1 (2-<7 y) N=15 n (%)	Group 2 (7-17 y) N=16 n (%)	Group 1 (2-<7 y) N=20 n (%)	Group 2 (7-17 y) N=29 n (%)
Base Grade 0 >=LLN to <=ULN	Grade 1 >ULN to <=1.5x ULN	2 (14)	1 (5)	2 (13)	5 (31)	3 (15)	1 (3)
	Grade 2 >1.5x ULN to <=3x ULN	2 (14)	2 (10)	1 (7)	3 (19)	0 (0.)	2 (7)
	Grade 3 >3x ULN to <=10x ULN	0 (0)	2 (10)	0 (0)	0 (0)	0 (0)	0 (0)
Base Grade 2 >ULN to <=1.5x ULN	Grade 2 >1.5x ULN to <=3x ULN	0 (0)	2 (10)	0 (0)	1 (6)	0 (0)	1 (3)
	Grade 3 >3x ULN to <=10x ULN	1 (7)	0 (0)	0 (0)	0 (0)	0 (0)	0 (0)
Base Grade 2: BILI >1.5x ULN to <=3x ULN		0 (0)	0 (0)	0 (0)	1 (6)	0 (0)	0 (0)
	Subjects(filtered)	5 (36)	7 (33)	3 (20)	10 (63)	3 (15)	4 (14)
	1stColltemSubjects	14 (100)	21 (100)	15 (100)	16 (100)	20 (100)	29 (100)

Source: Reviewer's analyses (JReview)

Electrolytes/Metabolism

Albumin: hypoalbuminemia is inversely correlated with increasing dose in older age group, but does not correlate with dose in younger age group.

Sodium: There were too few instances of hyponatremia 3/115 (3%) to determine dose dependency. Postbaseline increases in sodium were more prominent in 6 mg/kg dose group compared to 3.5mg/kg and 4.5 mg/kg groups (26% vs 13% and 11%, respectively).

Table 10-14 Change from Baseline, Hypernatremia

Baseline Hypernatremia Grade	Worst Hypernatremia Grade Post baseline	Treatment 3.5 mg/kg:		Treatment 4.5 mg/kg:		Treatment 6 mg/kg	
		Group 1 (2-<7 y) N=14 n (%)	Group 2 (7-17 y) N=21 n (%)	Group 1 (2-<7 y) N=15 n (%)	Group 2 (7-17 y) N=16 n (%)	Group 1 (2-<7 y) N=20 n (%)	Group 2 (7-17 y) N=29 n (%)
base NA below LLN	Grade 0: NA Normal	0 (0)	0 (0)	0 (0)	0 (0)	2 (10)	4 (14)
	Grade 2: NA >150 to <=155 mmol/L	0 (0)	0 (0)	1 (7)	0 (0)	0 (0)	0 (0)
Base Grade 0: NA Normal	Grade 1: NA >ULN to <=150 mmol/L	1 (7)	3 (14)	1 (7)	2 (13)	0 (0)	5 (17)

Version date: October 12, 2018

Baseline Hyponatremia Grade	Worst Hyponatremia Grade Post baseline	Treatment 3.5 mg/kg:		Treatment 4.5 mg/kg:		Treatment 6 mg/kg	
		Group 1 (2-<7 y) N=14 n (%)	Group 2 (7-17 y) N=21 n (%)	Group 1 (2-<7 y) N=15 n (%)	Group 2 (7-17 y) N=16 n (%)	Group 1 (2-<7 y) N=20 n (%)	Group 2 (7-17 y) N=29 n (%)
	Grade 2: NA >150 to <=155 mmol/L	0 (0)	0 (0)	0 (0)	0 (0)	1 (5)	1 (3)
	Subjects(filtered)	1 (7)	3 (14)	2 (13)	2 (13)	3 (15)	10 (35)
	1stColltemSubjects	14 (100)	21 (100)	15 (100)	16 (100)	20 (100)	29 (100)

Source: Reviewer's analyses (JReview)

Potassium: Postbaseline hypokalemia appears to affect nearly all patients across all dose and age cohorts. Postbaseline worsening in hyperkalemia was observed less frequently and did not appear to be age or dose-dependent.

Table 10-15 Change from Baseline, Hypokalemia

Baseline Hypokalemia Grade	Worst Hypokalemia Grade Post baseline	Treatment 3.5 mg/kg:		Treatment 4.5 mg/kg:		Treatment 6 mg/kg	
		Group 1 (2-<7 y) N=14 n (%)	Group 2 (7-17 y) N=21 n (%)	Group 1 (2-<7 y) N=15 n (%)	Group 2 (7-17 y) N=16 n (%)	Group 1 (2-<7 y) N=20 n (%)	Group 2 (7-17 y) N=29 n (%)
base potassium below ULN	Grade 0: >=LLN - <=ULN	0 (0)	0 (0)	1 (7)	0 (0)	0 (0)	0 (0)
	Grade 3: <3.0-2.5 mmol/L	1 (7)	0 (0)	0 (0)	0 (0)	0 (0)	0 (0)
Base Grade 0: >=LLN - <=ULN	base potassium above ULN	0 (0)	1 (5)	0 (0)	0 (0)	0 (0)	0 (0)
	Grade 3: <3.0-2.5 mmol/L	3 (21)	3 (14)	0 (0)	4 (25)	1 (5)	2 (7)
	Grade 4: <2.5 mmol/L	0 (0)	0 (0)	0 (0)	0 (0)	2 (10)	1 (3)
Base Grade 2: <LLN - 3.0 mmol/L	Grade 3: <3.0-2.5 mmol/L	0 (0)	0 (0)	0 (0)	0 (0)	1 (5)	0 (0)
	Grade 4: <2.5 mmol/L	0 (0)	0 (0)	0 (0)	0 (0)	0 (0)	0 (0)
	Subjects(filtered)	14 (100)	19 (91)	12 (80)	16 (100)	19 (95)	25 (86)
	Total Subjects	14 (100)	21 (100)	15 (100)	16 (100)	20 (100)	29 (100)

Source: Reviewer's analyses (JReview)

Table 10-16 Changes from Baseline, Hyperkalemia

Baseline Hypokalemia Grade	Worst Hyperkalemia Grade Post baseline	Treatment 3.5 mg/kg:		Treatment 4.5 mg/kg:		Treatment 6 mg/kg	
		Group 1 (2-<7 y) N=14 n (%)	Group 2 (7-17 y) N=21 n (%)	Group 1 (2-<7 y) N=15 n (%)	Group 2 (7-17 y) N=16 n (%)	Group 1 (2-<7 y) N=20 n (%)	Group 2 (7-17 y) N=29 n (%)
low: below LLN	Grade 1: >ULN-5.5 mmol/L	0 (0)	1 (5)	1 (7)	0 (0)	1 (5)	1 (3)
	Grade 2: >5.5-6.0 mmol/L	0 (0)	0 (0)	1 (7)	0 (0)	0 (0)	0 (0)
Grade 0	Grade 1: >ULN-5.5 mmol/L	4 (29)	4 (19)	6 (40)	2 (13)	4 (20)	10 (34)
	Grade 2: >5.5-6.0 mmol/L	1 (7)	1 (5)	0 (0)	2 (13)	2 (10)	0 (0)
	Grade 3: >6.0-7.0 mmol/L	0 (0)	1 (5)	0 (0)	1 (6)	1 (5)	0 (0)
	Grade 4: >7 mmol/L Life Threatening	1 (7)	0 (0)	0 (0)	0 (0)	0 (0)	0 (0)
	Subjects(filtered)	6 (43)	6 (29)	8 (53)	4 (25)	7 (35)	11 (38)
	Total Subjects	14 (100)	21 (100)	15 (100)	16 (100)	20 (100)	29 (100)

Source: Reviewer's analyses (JReview)

Magnesium: Few patients experienced postbaseline hyper or hypomagnesemia; no trends in postbaseline elevation or decrease in magnesium levels related to dose have been identified.

Table 10-17 Change from Baseline, Hypomagnesemia

Baseline Hypokalemia Grade	Worst Hypomagnesemia Grade Post baseline	Treatment 3.5 mg/kg:		Treatment 4.5 mg/kg:		Treatment 6 mg/kg	
		Group 1 (2-<7 y) N=14 n (%)	Group 2 (7-17 y) N=21 n (%)	Group 1 (2-<7 y) N=15 n (%)	Group 2 (7-17 y) N=16 n (%)	Group 1 (2-<7 y) N=20 n (%)	Group 2 (7-17 y) N=29 n (%)
Base Grade 0: Magnesium >=LLN to <=ULN	Grade 2: Hypomagnesemia <.5 to .4 mmol/L	1 (7)	1 (5)	1 (7)		1 (5)	2 (7)
	Subjects(filtered)	1 (7)	1 (5)	1 (7)		1 (5)	2 (7)
	Total Subjects	14 (100)	21 (100)	15 (100)		20 (100)	29 (100)

Source: Reviewer's analyses (JReview)

Table 10-18 Change from Baseline, Hypermagnesemia

Baseline Hypokalemia Grade	Worst Hypermagnesemia Grade Post baseline	Treatment 3.5 mg/kg:		Treatment 4.5 mg/kg:		Treatment 6 mg/kg	
		Group 1 (2-<7 y) N=14 n (%)	Group 2 (7-17 y) N=21 n (%)	Group 1 (2-<7 y) N=15 n (%)	Group 2 (7-17 y) N=16 n (%)	Group 1 (2-<7 y) N=20 n (%)	Group 2 (7-17 y) N=29 n (%)
base MG below LLN	Grade 0: Magnesium Normal		0	1 (7)	1 (6)	0	2 (7)

Version date: October 12, 2018

Baseline Hypokalemia Grade	Worst Hypermagnesemia Grade Post baseline	Treatment 3.5 mg/kg:		Treatment 4.5 mg/kg:		Treatment 6 mg/kg	
		Group 1 (2-<7 y) N=14 n (%)	Group 2 (7-17 y) N=21 n (%)	Group 1 (2-<7 y) N=15 n (%)	Group 2 (7-17 y) N=16 n (%)	Group 1 (2-<7 y) N=20 n (%)	Group 2 (7-17 y) N=29 n (%)
	Grade 1: HyperMG >ULN to <=1.23 mmol/L		0	0	0	1 (5)	0
	Grade 3: HyperMG >1.23 to <=3.3 mmol/L		0	0	0	1 (5)	0
Base Grade 0: Magnesium Normal	Grade 1: HyperMG >ULN to <=1.23 mmol/L		3 (14)	2 (13)	4 (25)	3 (15)	4 (14)
	Grade 4: HyperMG >3.3 mmol/L		0	0	0	1 (5)	0
	Subjects(filtered)		3 (14)	3 (20)	5 (31)	4 (20)	6 (21)

Source: Reviewer's analyses (JReview)Source: Reviewer's analyses (JReview)

Creatinine: Patients in 6 mg/kg dose cohort appear to have experienced worsening renal function on par with patients in 3.5 mg/kg dose cohort (18% each) as compared to only 6% of patients in 4.5 mg/kg dose group.

Table 10-19 Change from Baseline, Creatinine

Baseline Creatinine Grade	Worst Creatinine Grade Post baseline	Treatment 3.5 mg/kg:		Treatment 4.5 mg/kg:		Treatment 6 mg/kg	
		Group 1 (2-<7 y) N=14 n (%)	Group 2 (7-17 y) N=21 n (%)	Group 1 (2-<7 y) N=15 n (%)	Group 2 (7-17 y) N=16 n (%)	Group 1 (2-<7 y) N=20 n (%)	Group 2 (7-17 y) N=29 n (%)
base below lower limit	Grade 0: Normal	0 (0)	1 (5)	0 (0)	0 (0)	0 (0)	0 (0).
	Grade 1: >ULN to 1.5 x ULN	0 (0)	1 (5)	0 (0)	0 (0)	1 (5)	1 (3)
	Grade 2: >1.5 to 3 x ULN	0 (0)	0 (0)	0 (0)	0 (0.	0 (0)	1 (3)
	Grade 3: >3 to 6 x ULN	0 (0)	0 (0)	0 (0)	0 (0.	0 (0)	1 (3)
Grade 0: Normal	Grade 1: >ULN to 1.5 x ULN	1 (7)	1 (5)	1 (7)	0 (0)	3 (15)	2 (7)
	Grade 2: >1.5 to 3 x ULN	1 (7)	1 (5)	0 (0)	1 (6)	0 (0)	0 (0)
	Subjects(filtered)	2 (14)	4 (19)	1 (7)	1 (6)	4 (20)	5 (17)
	1stColltemSubjects	14 (100)	21 (100)	15 (100)	16 (100)	20 (100)	29 (100)

Source: Reviewer's analyses (JReview)

Hemoglobin: Nearly all patients on the study have experienced postbaseline worsening of anemia; however, no pattern that could have suggested a dose response in postbaseline anemia was identified.

Version date: October 12, 2018

Table 10-20 Change from Baseline, Hemoglobin

Baseline Anemia (Hb) Grade	Worst Anemia (Hb) Grade Post baseline	Treatment 3.5 mg/kg:		Treatment 4.5 mg/kg:		Treatment 6 mg/kg	
		Group 1 (2-<7 y) N=14 n (%)	Group 2 (7-17 y) N=21 n (%)	Group 1 (2-<7 y) N=15 n (%)	Group 2 (7-17 y) N=16 n (%)	Group 1 (2-<7 y) N=20 n (%)	Group 2 (7-17 y) N=29 n (%)
Base Grade 0: Hgb >=LLN to <=ULN	Grade 1: Hgb <LLN - 100 g/L	0 (0)	1 (5)	0 (0)	0 (0)	0 (0)	1 (3)
	Grade 2: Hgb <100 - 80g/L	0 (0)	1 (5)	0 (0)	0 (0)	1 (5)	0 (0)
	Grade 3: Hgb <80 g/L	0 (0)	1 (5)	1 (7)	1 (6)	1 (5)	2 (7)
Base Grade 1: Hgb <LLN - 100 g/L	Grade 2: Hgb <100 - 80g/L	2 (14)	3 (14)	1 (7)	1 (6)	3 (15)	3 (10)
	Grade 3: Hgb <80 g/L	2 (14)	2 (10)	1 (7)	0 (0)	0 (0)	0 (0)
Base Grade 2: Hgb <100 - 80g/L	Grade 3: Hgb <80 g/L	5 (36)	3 (14)	4 (27)	6 (36)	7 (35)	13 (45)
	Subjects(filtered)	14 (100)	20 (95)	15 (100)	16 (100)	20 (100)	28 (97)
	1stColltemSubjects	14 (100)	21 (100)	15 (100)	16 (100)	20 (100)	29 (100)

Source: Reviewer's analyses (JReview)

Platelets: The majority of the patients in the study experienced thrombocytopenia. A slightly greater proportion of patients in the 6 mg/kg group experienced worsening of their thrombocytopenia compared to the 3.5 and 4.5 mg/kg dose cohorts [45 (92%) vs. 28(80%) vs. 28 (90%)], respectively.

Table 10-21 Change from Baseline, Thrombocytopenia

Baseline Thrombocytopenia Grade	Worst Thrombocytopenia Grade Post baseline	Treatment 3.5 mg/kg:		Treatment 4.5 mg/kg:		Treatment 6 mg/kg	
		Group 1 (2-<7 y) N=14 n (%)	Group 2 (7-17 y) N=21 n (%)	Group 1 (2-<7 y) N=15 n (%)	Group 2 (7-17 y) N=16 n (%)	Group 1 (2-<7 y) N=20 n (%)	Group 2 (7-17 y) N=29 n (%)
Base Grade 0: Platelets Normal	Grade 2: Platelets <75 to >=50 10e9 /L	0 (0)	0 (0)	0 (0)	0 (0)	1 (5)	0 (0)
	Grade 3: Platelets <50 to >=25 10e9 /L	1 (7)	0 (0)	0 (0)	0 (0)	0 (0)	0 (0)
	Grade 4: Platelets <25 10e9 /L	2 (14)	3 (14)	0 (0)	3 (19)	1 (5)	1 (3)
Base Grade 1: Platelets <LLN to >=75 10e9 /L	Grade 3: Platelets <50 to >=25 10e9 /L	1 (7)	0 (0)	0 (0)	0 (0)	1 (5)	2 (7)
	Grade 4: Platelets <25 10e9 /L	3 (21)	4 (19)	4 (27)	1 (6)	6 (30)	2 (7)
Base Grade 2: Platelets <75 to >=50 10e9 /L	Grade 3: Platelets <50 to >=25 10e9 /L	0 (0)	0 (0)	0 (0)	0 (0)	2 (10)	0 (0)
	Grade 4: Platelets <25 10e9 /L	2 (14)	3 (14)	3 (20)	2 (13)	1 (5)	6 (21)
	Subjects(filtered)	10 (71)	18 (86)	12 (80)	16 (100)	20 (100)	25 (86)
	1stColltemSubjects	14 (100)	21 (100)	15 (100)	16 (100)	20 (100)	29 (100)

Source: Reviewer's analyses (JReview)

WBC/ANC: not patterns suggestive of dose related shifts in decreases in WBC/ANC were identified.

Version date: October 12, 2018

NDA Multi-disciplinary Review and Evaluation, sNDA 205596, 205053, 214770
NOXAFIL® (posaconazole) injection, delayed release tablet, PowderMix
For prophylaxis of invasive fungal infections in pediatric patients 2 years of age and older
For treatment of invasive aspergillosis in adults and pediatric patients 13 years and older

Vital Signs

There were no clinically meaningful changes in vital sign measurements or physical examinations. The largest increase in mean systolic blood pressure from baseline was 13 mmHg on Day 28 in the 3.5 mg/kg cohort, 5 mmHg on Day 3 in the 4.5 mg/kg cohort, and 23 mmHg on Day 27 for the 6mg/kg cohort with a median, mean, and range of systolic blood pressure measurements of 104, 104, and 79-138 mm Hg, respectively.

Electrocardiograms (ECGs)

QT

No clinically significant ECG changes suggestive of a dose-related QTc interval prolongation were identified.

Adverse Events of Special Interest

AEs of special interest included azole class effects and those reported in adult trials: dermatologic, CNS/psychiatric, ocular, hepatic, and adrenal disorders, and QT prolongation.

The most common adverse events of special interest reported consistently in the pediatric and adult patients included mucocutaneous adverse events, elevated LFTs, and hypokalemia.

10.2.5. P032: A Study of the Safety, Tolerance, and Pharmacokinetics of Oral Posaconazole (POS) in Immunocompromised Pediatric Subjects with Neutropenia

Refer to the clinical review for POS oral suspension, injection and delayed release tablet NDAs for the prophylaxis of invasive *Aspergillus* and *Candida* infections in patients 13 years of age and older. POS oral suspension was approved on 09/15/2006, and POS delayed release tablets and IV injection formulations were approved on 11/25/2013 and 03/13/2014, respectively.

10.2.6. Postmarketing Safety of Posaconazole in Pediatric Patients

Since 2005, there have been several post-marketing reports (>1400 from observational studies in published literature and 465 in the Applicant's global safety database) regarding the use of posaconazole for prophylaxis and treatment of IFI in pediatric patients younger than 18 years generally demonstrating a safety profile similar to that of adults.

Version date: October 12, 2018

10.3. Study P069: A Phase 3 Randomized Study of the Efficacy and Safety of Posaconazole versus Voriconazole for the Treatment of Invasive Aspergillosis in Adults and Adolescents

10.3.1. Review of the Safety Database

Study Design

The clinical development program for POS for the primary treatment of invasive aspergillosis (IA) includes a single Phase 3 trial conducted over a six-year period from 2013 to 2019. Study P069 was a randomized, prospective, double-blind, double-dummy, controlled trial of POS compared to VOR in patients aged >13 years of age with proven, probable, or possible IA as defined by the modified 2008 EORTC/MSG consensus criteria. The primary endpoint was all-cause mortality at Day 42. Patients received standard doses (IV or oral) of POS or VOR except that a 50% reduction in the dose of VOR was made for patients with Child Pugh class A and B. There were no dose adjustments for POS and no additional adjustments for VOR during the trial. A transition from IV to oral triazole therapy occurred when a patient was considered clinically stable. The design of Study P069 is summarized in Table 10-22 Study P069: Synopsis of Trial Design.

Safety Population

Among the 585 randomized patients, 10 (5 patients per study arm) did not receive study drugs. The safety population, known as APaT (All Patients as Treated), includes 575 randomized patients who received ≥1 dose of study drugs (POS, N=288 and VOR, N=287). The number of patients in the APaT and ITT populations are identical. The APaT population is hereafter referred to as the safety population.

Table 10-22 Study P069: Synopsis of Trial Design

Study Number (Status) Number of Study Centers (Countries)	Design (Indication)	Number of Subjects by Intervention Group	Study Population (N)
MK-5592-069 (completed) [Ref. 5.3.5.1: P069MK5592] 91 centers (26 countries)	Randomized, double-blind, double-dummy, parallel-group study Duration: 12 weeks (Treatment of invasive aspergillosis)	POS: 300 mg once daily (300 mg BID on Day 1) IV or PO: – 293 randomized/ 288 treated/ 184 completed VOR: 4 mg/kg IV BID (6 mg/kg IV BID on Day 1) or 200 mg PO BID (300 mg PO BID on Day 1): – 292 randomized/ 287 treated/ 177 completed Transition from IV to PO therapy when subject considered clinically stable and able to take PO medication	Gender: 344 males; 231 females Age range: 14 to 91 years Median age: 57 years Age <18 years: n=5 Age ≥65 years: n=160

BID=twice daily; IV=intravenously; PO=orally; POS=posaconazole; VOR=voriconazole

Source: Clinical study report, Study MK-5592-069.

Overall Exposure

Version date: October 12, 2018

Patients received POS 300mg IV or PO daily following a loading dose of 300mg BID on Day 1 of treatment. The planned duration of exposure to POS (intravenous (IV) and oral tablet) was 84 days with a maximum allowed duration of 98 days. The median duration of exposure was comparable between treatment groups, i.e., 67 days in the POS group and 64 days in the VOR group, Table 10-23. Approximately 60% of patients in each treatment group received a study drug for 42 days and approximately 40% received the planned duration of 84 days with similar proportions of patients in the POS and VOR treatments groups.

Table 10-23 Study 069: Treatment Duration by Treatment Arm - Safety Population

Treatment Duration (days)*	POS, N=288; n/N (%)	VOR, N=287; n/N (%)
1-7	28 (9.7)	33 (11.5)
8-14	31 (10.8)	30 (10.5)
15-28	30 (10.4)	38 (13.2)
29-42	22 (7.6)	14 (4.9)
43-84	94 (32.6)	87 (30.3)
85-98	79 (27.4)	80 (27.9)
>98	4 (1.4)	5 (1.7)
Treatment duration (cumulative days)		
≥ 1	288 (100)	287 (100)
≥ 7	264 (91.7)	258 (89.9)
≥ 14	232 (80.6)	232 (80.3)
≥ 28	203 (70.5)	189 (65.9)
≥ 42	180 (62.5)	173 (60.3)
≥ 84	115 (39.9)	107 (37.3)
≥ 98	12 (4.2)	12 (4.2)
Summary Statistics		
Mean (days)	56.2	54.5
SD	34	34.6
Median (day)	67	64
Range (Days)	1-112	2 - 112

Source: Adapted from Tables 10-10 and 10-11 in CSR, Study MK-5592-069. *Duration is based on treatment start date and treatment end date and does not consider possible dosing interruptions and subject noncompliance.

Clinical reviewer's comment: In Study P069, POS was administered for longer durations of up to 112 days (median 67 days) as compared to the median of 28 days in the registrational clinical trials for the IFI prophylaxis for POS IV and POS delayed-release tablet and at the same dose, 300mg/day. Exposure to POS treatment in 180 patients (62.5%) for 6 weeks and 115 patients (39.9%) for 12 weeks of POS is considered adequate to assess the safety of POS.

Exposure to IV and oral formulations of POS and VOR

In the POS and VOR treatment groups, 56% and 60% of patients, respectively, started treatment with the IV formulations. For those patients who started on IV therapy, the median duration of the first instance of POS or VOR treatment before switching to oral treatment (or discontinuing treatment or

Version date: October 12, 2018

completing treatment) was 9 days in both treatment groups, Table 10-24. A larger proportion of patients in the POS group started with oral drug, (POS, 44% vs. VOR, 40%); however, the differences between treatment groups were small and are not likely to be of clinical significance from a safety perspective.

Table 10-24 Study P069: Duration of Exposure to Study Drugs (IV and Oral) – Safety Population

Antifungal Treatment	POS N=288	VOR N=287	Total N=575
	n /N (%)	n/N (%)	n/N (%)
Patients starting with IV drug	161 (55.9)	171 (59.6)	332 (57.7)
Patients starting with oral drug	127 (44.1)	116 (40.4)	243 (42.3)
Total duration of first instance of IV treatment (days)*			
Mean	12.8	11.7	12.2
SD	12.8	10.1	11.5
Median	9	9	9
Range	1- 81	1- 67	1-81
Total duration on IV treatment (Days)			
Mean	15.5	13.3	14.4
SD	15.3	11.4	13.5
Median	10	10	10
Range	1-81	1-67	1-81

*Patients who started on IV antifungal treatment.

Source: Table constructed by reviewer.

Clinical reviewer's comment: The median duration of IV therapy for 9 days in both treatment arms is considered an adequate length of exposure for the assessment of the safety of POS IV in patients.

Disposition of Study Subjects

The proportions of patients who completed study treatment or completed the trial were comparable in the POS and VOR treatment groups, Table 10-25. Death was the most common reason for discontinuation from the trial and occurred at a similar frequency in both treatment groups. AEs were the most common reason for discontinuation of the study drugs, and there fewer AE-related discontinuations in the POS treatment group, [POS, 93 patients (32.3%) vs. VOR, 102 patients (35.5%)]. Twenty patients (3.5%) withdrew from the trial, 10 patients per treatment group. Losses to follow-up or noncompliance were infrequent at $\leq 1\%$.

Table 10-25 Study P069: Disposition of Study Subjects in the Safety Population

Subject Disposition	Posaconazole IV/PO N=288	Voriconazole IV/PO N=287	Total N=575
	n/N (%)	n/N (%)	n/N (%)
Completed Trial	184 (63.9)	177 (61.7)	361 (62.8)
Completed Treatment	139 (48.3)	142 (49.5)	281 (48.9)
Treatment Duration median (range in days)*	67 (1- 112)	64 (2 – 112)	NA
Reason for Discontinuation from Trial			

Version date: October 12, 2018

NDA Multi-disciplinary Review and Evaluation, sNDA 205596, 205053, 214770
 NOXAFIL® (posaconazole) injection, delayed release tablet, PowderMix
 For prophylaxis of invasive fungal infections in pediatric patients 2 years of age and older
 For treatment of invasive aspergillosis in adults and pediatric patients 13 years and older

Subject Disposition	Posaconazole IV/PO N=288	Voriconazole IV/PO N=287	Total N=575
Death	93 (32.3)	96 (33.4)	189 (32.9)
Lost to follow up	1 (0.3)	3 (1.0)	4 (0.7)
Other	0	1 (0.3)	1(0.2)
Withdrawal by subject	10 (3.5)	10 (3.5)	20 (3.5)
Reason for Discontinuation from Treatment			
Adverse Event	93 (32.3)	102 (35.5)	195 (33.9)
Adverse Event (considered drug related)	67 (23.3)	68 (23.7)	135 (23.5)
Death	26 (9.0)	35 (12.2)	61 (10.6)
Lost to follow -up	1 (0.3)	0	1 (0.2)
Non-compliance with study drug	4 (1.4)	2 (0.7)	6 (1.0)
Physician Decision	38 (13.2)	32 (11.1)	70 (12.2)
Protocol deviation	1(0.3)	0	1 (0.2)
Withdrawal by subject	12 (4.2)	8 (2.8)	20 (3.5)

Source: OCS Analysis Studio, Custom Table Tool. Variables: DCREAS, DCTREAS
 Columns - Dataset: Demographics; Filter: ITTFL = 'Y'.

Table Section 1 - Dataset: Demographics; Filter: ITTFL = 'Y'.

*Duration of treatment is based on treatment begin date and treatment end date and does not consider possible dosing interruptions and subject noncompliance.

10.3.2. Adequacy of the safety database

The study population included patients with hematological malignancies, hematopoietic stem cell transplant or solid organ transplants at 91 study sites in 26 countries across Asia/Pacific region, Europe, and North and South America were representative of the patient population with invasive aspergillosis (IA). The safety database for POS includes 288 patients with invasive aspergillosis (IA) who received POS IV for a median of 9 days and received IV and delayed-release tablet for a median of 67 days (2 to 112 days); 180 patients (62.5%) received POS treatment for 6 weeks and 115 patients (39.9%) received POS for 12 weeks. The median duration of treatment in Study P069 is longer than the median exposure of 28 days in the trials that formed the basis of approval for these two formulations for the prophylaxis of IFIs. The size of the safety database was agreed with the Applicant during pre-NDA discussions and is marginally larger than the database in the registrational phase 3 trial of isavuconazonium sulfate (vs. VOR) for treatment of invasive aspergillosis. ^{Error! Bookmark not defined.} The reviewer considers the safety database adequate to assess the safety of POS for the treatment of IA.

10.3.3. Adequacy of Applicant's Clinical Safety Assessments

Issues Regarding Data Integrity and Submission Quality

The quality of the clinical study report and the ADaM datasets for Study P069 were satisfactory and there were no issues related to data integrity.

Categorization of Adverse Events

Adverse events were coded using MedDRA version 22.1. Adverse events were flagged as treatment emergent in the ADAE dataset. Adverse events were graded using the NCI CTCAE version 4.0 and

Version date: October 12, 2018

laboratory test abnormalities were categorized using CTC grading of severity.

Routine Clinical Tests

Safety evaluations were performed as per protocol at all study visits [screening (visit 1), baseline (visit 2), during treatment (visits 3 through 8), follow up (visit 9, 10)] and at unscheduled visits. Safety assessments included assessments of adverse events (AEs), clinical laboratory tests (hematology, chemistry, and urinalysis), diagnostic imaging (high resolution CT scan), vital signs, physical examinations including height and body weight, and 12-lead electrocardiograms (ECGs). The incidence of SAEs, TEAEs, and drug-related AEs, and selected AEs of interest (hepatic, CNS /visual, dermatologic AEs, and abnormalities of adrenal steroidogenesis) were summarized by treatment groups. Summary statistics for laboratory test results and ECG findings were presented as changes from baseline. Fridericia's and Bazett's formulae were used to calculate QTc.

Measurement of Study Drug levels

Therapeutic drug monitoring was not performed as per protocol to maintain blinding. Blood samples for pre-dose posaconazole and voriconazole levels were collected intermittently from patients for PK analyses throughout the course of study drug treatment.

10.3.4. Safety Results

1.1.1.1. Overall Summary of Reported Adverse Events

TEAEs occurred in 98% of patients in POS and VOR treatment groups, Table 10-26. The incidence rates of severe TEAEs or treatment emergent SAEs were comparable between the two groups (approx. 60%) and were marginally more common in the POS group. TEAEs leading to death occurred in 30% of patients in both treatment groups. TEAEs leading to permanent discontinuation treatment in the POS group (32.3%) were marginally lower than in the VOR group (35.5%).

Table 10-26 Study P069: Summary of Treatment Emergent Adverse Events

Treatment Emergent Adverse Events (TEAEs)	Posaconazole N=288		Voriconazole N=287	
	N	%	N	%
Patients with any TEAE	281	97.6	280	97.6
Patients with severe TEAE	188	65.3	182	63.4
Patients with any treatment emergent SAE	178	61.8	172	59.9
Patients with any TEAE leading to death	86	29.9	87	30.3
Patients with any TEAE leading to permanent treatment discontinuation	93	32.3	102	35.5

Source: JMP Clinical, v7.1.2; ADSL, ADAE datasets. . N (%): Number and percentage of subjects with at least one TEAE. TEAE: Treatment emergent adverse event, SAE: Serious adverse event Adverse events (AEs) reported from the first dose of study treatment through 30 days after the last dose.

Version date: October 12, 2018

1.1.1.2. Deaths

A total of 197 deaths (34.3%) were reported during and outside of the trial period; 99 deaths (34.4%) in the POS group and 98 deaths (34.1%) in the VOR group, Table 10-27. During the trial period (Day 1 to 114), 185 patients died, with a similar numbers of deaths occurring in the two treatment groups, [POS, 92 patients (31.9%) vs. VOR, 93 patients (32.4%)]. The survival status of 3 patients in the VOR group was unknown or missing, and when these 3 patients were counted as deaths, deaths increased to 96 (33.4%) in the VOR group. Twelve deaths, 6 patients (2.1%) in each treatment group, were reported outside the trial period between Day 116 and Day 224. All deaths are summarized in Table 15-11 Study P069: Listing of Deaths (N = 197) by Cause of Death and Day of Death .

Table 10-27 Study P069: Deaths from Study Day 1 through Day 114*

	POS N=288 n/N(%)	VOR N=287 n/N(%)	Total N=575 n/N(%)
Survival Status			
Alive	196 (68.1)	191 (66.6)	387 (67.3)
Dead	92 (31.9)	93 (32.4) [§]	185 (32.2)
Unknown status [†]	0	2 (0.7)	2 (0.3)
Missing	0	1 (0.3)	1 (0.2)

Source: Adapted from Table 14.2-6 in CSR, Study P069-MK5592. *Day 114 is last day of the trial. [§]The survival status of 3 patients in the VOR group was unknown or missing and when counted as deaths, increased the total deaths to 96 (33.4%) in the VOR arm.

[†]Unknown status included no contact made, lost to follow-up, or subject withdrew consent.

Clinical reviewer's comment: The reported all-cause mortality rate for VOR for treatment of IA in Study P069 was examined for consistency with the all-cause mortality rates reported for VOR in other phase 3, IA treatment trials. In Study P069, the all-cause mortality rate through Day 84 was 31% in the ITT population. In the registrational phase 3, randomized controlled trial of VOR vs. amphotericin B for the primary treatment of invasive aspergillosis, the all-cause mortality rate through Day 84 was 29% for VOR in the ITT population of patients with hematological malignancies.¹⁴ In the phase 3, IA treatment trial of isavuconazonium sulfate vs. VOR, the all-cause mortality rate through Day 84 was 31% in VOR-treated patients in the ITT population of patients with hematological malignancies.¹⁵

Causes of Death

¹⁴ Herbrecht R, Denning DW, Patterson TF, et al. Invasive Fungal Infections Group of the European Organisation for Research and Treatment of Cancer and the Global Aspergillus Study Group. Voriconazole versus amphotericin B for primary therapy of invasive aspergillosis. *N Engl J Med.* 2002;347(6):408-15. doi: 10.1056/NEJMoa020191.

¹⁵ Maertens JA, Raad II, Marr KA, et al. Isavuconazole versus voriconazole for primary treatment of invasive mould disease caused by Aspergillus and other filamentous fungi (SECURE): a phase 3, randomized-controlled, non-inferiority trial. *The Lancet* 2016; 387 (10020):760-769.

Version date: October 12, 2018

In the POS arm, the common primary causes of death were septic shock (12 patients, 4.2%), respiratory failure (8, 2.8%), acute myeloid leukemia (6, 2.1%), pneumonia (5, 1.7%), and sepsis (5, 1.7%), Table 10-28. The primary causes of death in the POS treatment group were similar to the VOR group. A cause of death was not reported for 8 patients [(POS, 3 patients (1%) and VOR, 5 patients (1.7%)]. Many of the deaths were due to complications of the patients' underlying hematological malignancies such as sepsis, pneumonia, and hemorrhage. Invasive aspergillosis was listed as the primary cause of death in 7 patients (POS, 3 patients, VOR, 4 patients) which appears rather low for an invasive aspergillosis trial, and deaths due to IA are probably more accurately reflected in the attributable causes of death assigned by an independent Clinical Adjudication Committee (CAC), Table 10-29.

Table 10-28 Study P069: Causes of Death Occurring in $\geq 0.5\%$ Subjects in Safety Population

Primary Cause of death	Posaconazole	Voriconazole	Total
	N=288 n/N (%)	N=287 n/N (%)	(N=575 n/N (%)
Septic shock	12 (4.2)	13 (4.5)	25 (4.3)
Respiratory failure	8 (2.8)	5 (1.7)	13 (2.3)
Acute myeloid leukemia	6 (2.1)	14 (4.9)	20 (3.5)
Pneumonia	5 (1.7)	3 (1.0)	8 (1.4)
Sepsis	5 (1.7)	4 (1.4)	9 (1.6)
Death (cause not specified)	3 (1.0)	5 (1.7)	8 (1.4)
Acute lymphocytic leukemia	2 (0.7)	2 (0.7)	4 (0.7)
Acute lymphocytic leukemia recurrent	2 (0.7)	0	2 (0.3)
Bacteremia	2 (0.7)	0	2 (0.3)
Bronchopulmonary aspergillosis	2 (0.7)	1 (0.3)	3 (0.5)
Cardiac failure	2 (0.7)	0	2 (0.3)
Cerebral hemorrhage	2 (0.7)	1 (0.3)	3 (0.5)
Hemorrhage intracranial	2 (0.7)	0	2 (0.3)
Leukemia	2 (0.7)	0	2 (0.3)
Myelodysplastic syndrome	2 (0.7)	0	2 (0.3)
Acute respiratory distress syndrome	1 (0.3)	2 (0.7)	3 (0.5)
<i>Aspergillus</i> infection	1 (0.3)	3 (1.0)	4 (0.7)
Multiple organ dysfunction syndrome	1 (0.3)	2 (0.7)	3 (0.5)
Plasma cell myeloma	1 (0.3)	3 (1.0)	4 (0.7)
Pulmonary hemorrhage	1 (0.3)	2 (0.7)	3 (0.5)
Gastrointestinal hemorrhage	0	2 (0.7)	2 (0.3)
Mucormycosis	0	3 (1.0)	3 (0.5)
Pneumonia bacterial	0	2 (0.7)	2 (0.3)
Pneumonia fungal	0	2 (0.7)	2 (0.3)

Source: OCS Analysis Studio, Custom Table Tool.

Columns - Dataset: Demographics; Filter: TRTFL = 'Y'.

Dataset: Demographics; Filter: DTHFL = 'Y'; Percent Threshold: $\geq 0.5\%$; variable: DTHCAUS

Attribution of Cause of Death

Attribution of deaths in the trial was determined by an independent Clinical Adjudication Committee (CAC), Table 10-29. Deaths were attributed to invasive aspergillosis in 41 patients (21%) with a higher proportion in the POS group, (POS 23%, VOR 18%), Table 10-29. The “*indeterminate attribution of death*” category included the greatest proportion of deaths, in the two treatment groups, (POS 43%, VOR 45%). An accurate comparison between treatment-groups for attribution of death was not feasible
Version date: October 12, 2018

for IA, invasive fungal disease (IFI) other than invasive aspergillosis, or other cause of death due to the high proportion of deaths adjudicated to have an 'indeterminate' cause.

Table 10-29 Study P069: Attribution of deaths by CAC* through end of trial

	Posaconazole IV/oral N=99, n/N(%)	Voriconazole N=98 n/N(%)	Total N=197 n/N(%)
No data/Missing	7 (7.1)	4 (4.1)	11 (5.6)
Death Attributed to Invasive Aspergillosis	23 (23.2)	18 (18.4)	41 (20.8)
Death Attributed to Invasive Fungal Disease Other Than Invasive Aspergillosis	3 (3.0)	7 (7.1)	10 (5.1)
Death Not Attributable to Invasive Aspergillosis or Other Invasive Fungal Disease	23 (23.2)	25 (25.5)	48 (24.4)
Indeterminate Attribution of Death	43 (43.4)	44 (44.9)	87 (44.2)

Source: OCS Analysis Studio, Custom Table Tool.

Columns - Dataset: Demographics; Filter: ITTFL = 'Y', DTHFL = 'Y'.

Dataset: ADBASE; Filter: ITTFL = 'Y', variable ADJDTHC

*CAC: Clinical Adjudication Committee (independent committee)

All-cause mortality

The cumulative all-cause mortality rates through the end of study treatment (Day 84) and throughout the study period (i.e., through Day 114) in the Safety population are summarized in Figure 10-1. All-cause mortality rates were comparable through Day 84 in the POS and VOR treatment groups in the ITT population, (POS, 28.1% vs. VOR, 30.7%); estimated difference -2.5% [95% CI: -9.9, 4.9%]. All-cause mortality rates were lower in the POS group during the treatment phase through Day 84, and there was a trend toward separation of the mortality curves favoring POS.

At the end of drug treatment (Day 84), 71.9% and 69.3% of subjects in the POS and VOR treatment groups, respectively, were alive. At the end of the trial (Day 114), 196 patients (68.1%) and 191 patients (66.6%) in the POS and VOR treatment groups, respectively, were alive. See comprehensive statistical evaluation of mortality endpoints, section 8.

Version date: October 12, 2018

Figure 10-1 Study P069: Kaplan-Meier Plot for Cumulative All-Cause Mortality Rate Through Day 114 - Safety Population

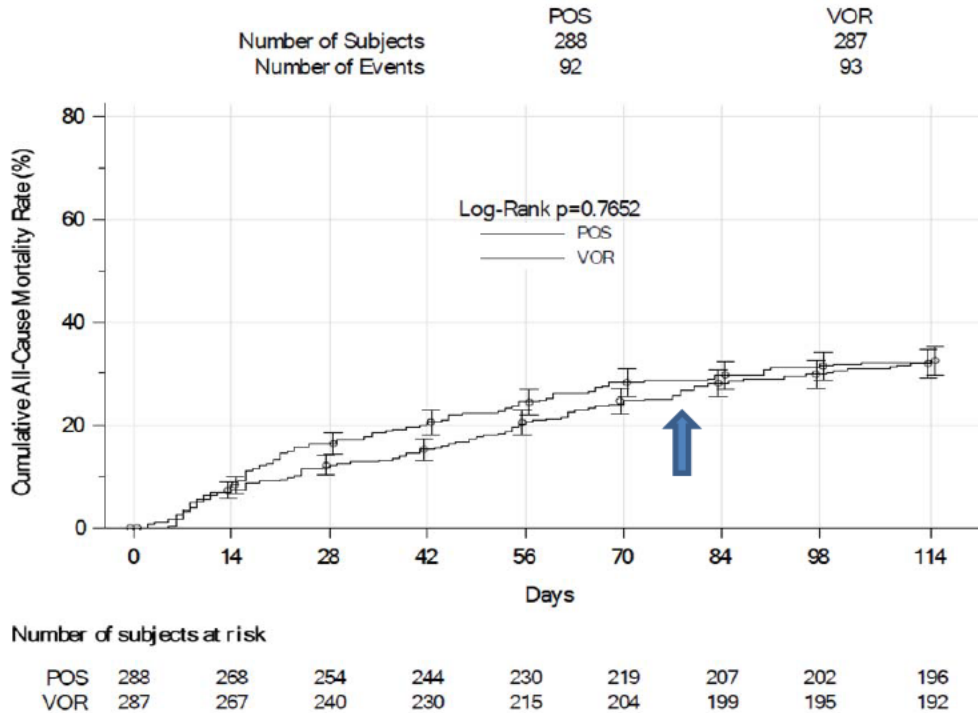

Note: Arrow in graph points to curve for POS

Source: Adapted from Fig 11- 5 of the CSR, Study MK-5592-069

1.1.1.3. Serious Adverse Events

The proportions of subjects who experienced SAEs were comparable in the two treatment groups, POS 62% vs. VOR 60%. The most common body system organ classes (SOCs) affected were *Infections and Infestations* (POS, 33.3% vs. VOR, 31.7%), *Respiratory, Thoracic and Mediastinal Disorders* (POS, 12.2% vs. VOR, 9.1%), and *Blood and Lymphatic disorders* (POS, 11.5% vs. VOR, 9.4%). Table 10-30 summarizes SAEs occurring at rate $\geq 1\%$ of patients in the Safety population. SAEs in the POS arm were mostly related to IA, other bacterial, fungal (candidiasis, fusariosis, mucormycosis), and viral (cytomegalovirus, influenza) infections and complications of underlying hematological malignancies. There were no fatal SAEs in the POS group. Three patients in the VOR group developed SAEs of pancreatitis (n=1), cerebral disorder (n=1), and encephalopathy (n=1) which were associated with fatal outcomes.

In the POS group, the most common SAEs with incidence $\geq 5\%$ (febrile neutropenia, pneumonia, and septic shock) were comparable to the VOR group (febrile neutropenia and septic shock). The incidence and types of other SAEs were generally similar between the POS and the VOR treatment groups except

Version date: October 12, 2018

for hypokalemia (POS 4 patients vs. VOR 0 patients), hemoptysis (POS, 4 patients vs VOR 0 patients), and hypotension (POS 3 patients vs. VOR 0 patients). Hemoptysis was probably related to complications of pulmonary aspergillosis, other underlying pulmonary disease or thrombocytopenia. Hypokalemia and hypotension are further evaluated in sections, 10.2.8 and 10.3.

Table 10-30 Study P069: Serious adverse events occurring ≥ 1% subjects in Safety Population

	Posaconazole N=288 n/N (%)	Voriconazole N=287 n/N (%)	Total N=575 N/N (%)
Patients with ≥ 1 SAE	178 (61.8)	172 (59.9)	350 (60.9)
Infections and infestations	96 (33.3)	91 (31.7)	187 (32.5)
Pneumonia	30 (10.4)	22 (7.7)	52 (9.0)
Septic shock	16 (5.6)	16 (5.6)	32 (5.6)
Sepsis	11 (3.8)	7 (2.4)	18 (3.1)
Aspergillosis, invasive	6 (2.1)	9 (3.1)	15 (2.6)
Bacterial sepsis	5 (1.7)	8 (2.8)	13 (2.3)
Bacteremia	5 (1.7)	3 (1.0)	8 (1.4)
Cytomegalovirus disease	2 (0.7)	4 (1.4)	6 (1.0)
Escherichia bacteremia	3 (1.0)	2 (0.7)	5 (0.9)
Influenza	3 (1.0)	1 (0.3)	4 (0.7)
Respiratory, thoracic and mediastinal disorders	35 (12.2)	26 (9.1)	61 (10.6)
Respiratory failure	10 (3.5)	7 (2.4)	17 (3.0)
Acute respiratory distress syndrome	3 (1.0)	2 (0.7)	5 (0.9)
Pulmonary edema	1 (0.3)	4 (1.4)	5 (0.9)
Acute respiratory failure	1 (0.3)	3 (1.0)	4 (0.7)
Hemoptysis	4 (1.4)	0	4 (0.7)
Hypoxia	3 (1.0)	1 (0.3)	4 (0.7)
Pulmonary hemorrhage	0	3 (1.0)	3 (0.5)
Blood and lymphatic system disorders	33 (11.5)	27 (9.4)	60 (10.4)
Febrile neutropenia	24 (8.3)	21 (7.3)	45 (7.8)
Bone marrow failure	3 (1.0)	2 (0.7)	5 (0.9)
Neoplasms benign, malignant and unspecified (incl cysts and polyps)	27 (9.4)	26 (9.1)	53 (9.2)
Acute leukemia	14 (4.9)	16 (5.6)	30 (5.2)
Gastrointestinal disorders	14 (4.9)	17 (5.9)	31 (5.4)
Gastrointestinal hemorrhage	0	3 (1.0)	3 (0.5)
Nervous system disorders	12 (4.2)	19 (6.6)	31 (5.4)
Encephalopathy	3 (1.0)	5 (1.7)	8 (1.4)
Cerebral hemorrhage	3 (1.0)	3 (1.0)	6 (1.0)
General disorders and administration site conditions	12 (4.2)	13 (4.5)	25 (4.3)
Pyrexia	7 (2.4)	5 (1.7)	12 (2.1)
Multiple organ dysfunction syndrome	0	3 (1.0)	3 (0.5)
Cardiac disorders	11 (3.8)	9 (3.1)	20 (3.5)
Atrial fibrillation	4 (1.4)	2 (0.7)	6 (1.0)
Cardiac failure	3 (1.0)	2 (0.7)	5 (0.9)
Hepatobiliary disorders	9 (3.1)	7 (2.4)	16 (2.8)
Hepatic function abnormal	3 (1.0)	1 (0.3)	4 (0.7)
Renal and urinary disorders	10 (3.5)	6 (2.1)	16 (2.8)
Acute kidney injury	9 (3.1)	5 (1.7)	14 (2.4)
Investigations	7 (2.4)	7 (2.4)	14 (2.4)

Version date: October 12, 2018

	Posaconazole N=288 n/N (%)	Voriconazole N=287 n/N (%)	Total N=575 N/N (%)
Transaminases increased	3 (1.0)	4 (1.4)	7 (1.2)
Metabolism and nutrition disorders	9 (3.1)	3 (1.0)	12 (2.1)
Hypokalemia	4 (1.4)	0	4 (0.7)
Immune system disorders	6 (2.1)	5 (1.7)	11 (1.9)
Graft versus host disease	2 (0.7)	3 (1.0)	5 (0.9)
Vascular disorders	6 (2.1)	1 (0.3)	7 (1.2)
Hypotension	3 (1.0)	0	3 (0.5)

Source: OCS Analysis Studio, Custom Table Tool.

Columns - Dataset: Demographics; Filter: TRTFL = 'Y'. AEDECODG

Table Section 1 - Dataset: Adverse Events; Filter: TRTEMFL = 'Y', AESER = 'Y'; Percent Threshold: >= 1%.

SAEs leading to treatment discontinuation

SAEs leading to treatment discontinuation were reported for 27.5% of patients in the trial, (POS, 26.4% and VOR, 28.6%). The most frequently reported SAEs leading to treatment discontinuation were septic shock (2.8%) and respiratory failure (2.4%) in the POS group, and septic shock (2.8%) and acute myeloid leukemia (2.8%) in the VOR group.

Drug-related SAEs

Table 10-31 summarizes the patients with drug related SAEs as assessed by the study site investigators, [POS, 16 patients (5.6%) vs. VOR, 20 patients (7.0%)]. The most commonly reported drug related SAEs were ALT increased (n=3) in the POS treatment group and encephalopathy (n=3) in the VOR treatment group (not shown).

In the POS group, 16 patients (5.6%) experienced drug related SAEs of which 10 patients were “recovered/resolved” and 6 patients were “not recovered/not resolved”.

POS was discontinued in 10 patients (3.5%) as compared to 14 (4.9) in the VOR group. Severe SAEs included elevated aminotransferases or hyperbilirubinemia or gamma glutamyl transferases (7 patients), hallucinations (2 patients), and exfoliative dermatitis generalized (1), gastrointestinal disorders (1), abdominal pain (1), bone marrow failure (1), acute kidney injury (1) and seizure (1). Study treatment was prematurely unblinded for the patient with generalized exfoliative dermatitis and POS was discontinued (see section 10.3).

Version date: October 12, 2018

Table 10-31 P069: Summary of Subjects with Drug-Related SAEs - Posaconazole

Subject ID	Onset Epoch	Rel Day of Onset	Adverse Event	Duration	Intensity	Action Taken	Outcome
Posaconazole							
(b) (6)	Treatment	9	Confusional state Hallucination	Continuing 2 Days	Moderate Moderate	None None	Not Resolved Resolved
(b) (6)	Follow-Up	68	Hepatic function abnormal	Continuing	Severe	Discontinued	Not Resolved
(b) (6)	Treatment	9	Gastrointestinal disorder	6 Days	Severe	Discontinued	Resolved
(b) (6)	Treatment	4	Gamma-glutamyltransferase increased	3 Weeks	Severe	None	Resolved
(b) (6)	Treatment	22	Encephalopathy	2.71 Weeks	Severe	Discontinued	Resolved
(b) (6)	Treatment	7	Dermatitis exfoliative generalised	1.57 Weeks	Severe	Discontinued	Resolved
(b) (6)	Treatment	8	Alanine aminotransferase increased	5 Days	Severe	Interrupted	Resolved
(b) (6)	Treatment	8	Aspartate aminotransferase increased	5 Days	Severe	Interrupted	Resolved
(b) (6)	Treatment	30	Acute kidney injury	1.57 Weeks	Severe	Discontinued	Resolved

Subject ID	Onset Epoch	Rel Day of Onset	Adverse Event	Duration	Intensity	Action Taken	Outcome
Posaconazole							
(b) (6)	Treatment	7	Hyperbilirubinaemia	Continuing	Severe	None	Not Resolved
(b) (6)	Treatment	6	Alanine aminotransferase increased	Continuing	Severe	Discontinued	Not Resolved
(b) (6)	Treatment	6	Aspartate aminotransferase increased	Continuing	Severe	Discontinued	Not Resolved
(b) (6)	Treatment	13	Abdominal pain	2 Weeks	Severe	None	Resolved
(b) (6)	Treatment	5	Gamma-glutamyltransferase increased	Continuing	Severe	None	Not Resolved
(b) (6)	Treatment	14	Hallucination	2 Days	Mild	Discontinued	Resolved
(b) (6)	Follow-Up	64	Bone marrow failure	Continuing	Severe	Discontinued	Not Resolved
(b) (6)	Treatment	4	Hepatic function abnormal	3.14 Weeks	Severe	Discontinued	Resolved
(b) (6)	Treatment	49	Seizure	40 Minutes	Severe	Discontinued	Resolved

Subject ID	Onset Epoch	Rel Day of Onset	Adverse Event	Duration	Intensity	Action Taken	Outcome
Posaconazole							
(b) (6)	Treatment	38	Alanine aminotransferase increased	1.35 Months	Moderate	None	Resolved

Source: Adapted from section 16.2.7.1.5, Subjects with Drug-related Serious Adverse Events, All Subjects as Treated (aAPaT)

Overall, the proportions of patients with SAEs were comparable in both groups, as were the proportions of subjects with drug related SAEs, discontinuations due to SAEs and drug related SAEs.

Clinical reviewer's comment: There were no SAEs leading to death in the POS group as compared to 3
Version date: October 12, 2018

reports of drug related fatal SAEs in 3 patients in the VOR group. The study site investigators concluded that the 3 SAEs, pancreatitis (n=1), cerebral disorder (n=1), encephalopathy (n=1) were related to VOR. This reviewer's assessment of the case narratives for the three deaths indicate that the attributions of the deaths to VOR could not be ruled out but were confounded by the patients' underlying diseases and multiple concomitant medications.

Similar incidences of SAEs were reported in the registrational studies for POS IV for injection (27%) and POS delayed-release tablets (33%) at the 300mg daily dose of POS and in a similar population of patients with hematological malignancies.

1.1.1.4. Treatment Emergent Adverse Events

In Study P069, 98% of the patients in the POS and VOR treatment groups experienced at least one treatment emergent adverse event (TEAE), Table 10-32. TEAEs within the *Infections and Infestations*, *Gastrointestinal Disorders*, and *General/Administration Site Disorders* SOCs were the most frequently reported. TEAEs in the *Respiratory, Thoracic And Mediastinal Disorders* (POS, 49% vs. VOR, 37.6%) and *Metabolism and Nutrition Disorders* (POS, 49.3% vs. VOR, 38%) displayed the greatest imbalances between the two treatment groups. Hepatobiliary disorders, which are known to be associated with azole drugs, occurred more frequently in the POS group, (POS 13.5% vs. VOR 9.1%). Hepatic TEAEs are further discussed in the sections, *Laboratory Findings* (10.2.8) and *TEAEs of Special Interest* (10.3).

Table 10-32 Study P069: Treatment Emergent Adverse Events by System Organ Class occurring at ≥ 5% - Safety Population

	Posaconazole (N=288) n/N(%)	Voriconazole (N=287) n/N%	Total (N=575) n/N%
No. patients with at least 1 TEAE	281 (97.6)	280 (97.6)	561 (97.6)
Infections and infestations	191 (66.3)	185 (64.5)	376 (65.4)
Pneumonia	46 (16.0)	43 (15.0)	89 (15.5)
Cytomegalovirus disease	18 (6.2)	20 (7.0)	38 (6.6)
Septic shock	17 (5.9)	16 (5.6)	33 (5.7)
Bacteremia	19 (6.6)	11 (3.8)	30 (5.2)
Urinary tract infection	17 (5.9)	11 (3.8)	28 (4.9)
Sepsis	15 (5.2)	9 (3.1)	24 (4.2)
Gastrointestinal disorders	162 (56.2)	163 (56.8)	325 (56.5)
Nausea	65 (22.6)	51 (17.8)	116 (20.2)
Diarrhea	52 (18.1)	52 (18.1)	104 (18.1)
Vomiting	52 (18.1)	39 (13.6)	91 (15.8)
Abdominal pain	37 (12.8)	36 (12.5)	73 (12.7)
Constipation	32 (11.1)	23 (8.0)	55 (9.6)
General disorders and administration site conditions	155 (53.8)	137 (47.7)	292 (50.8)
Pyrexia	81 (28.1)	72 (25.1)	153 (26.6)
Edema peripheral	32 (11.1)	24 (8.4)	56 (9.7)
Chest pain	18 (6.2)	11 (3.8)	29 (5.0)
Fatigue	19 (6.6)	7 (2.4)	26 (4.5)
Chills	15 (5.2)	8 (2.8)	23 (4.0)
Metabolism and nutrition disorders	142 (49.3)	109 (38.0)	251 (43.7)

Version date: October 12, 2018

	Posaconazole (N=288) n/N(%)	Voriconazole (N=287) n/N%	Total (N=575) n/N%
No. patients with at least 1 TEAE	281 (97.6)	280 (97.6)	561 (97.6)
Hypokalemia	82 (28.5)	49 (17.1)	131 (22.8)
Hypomagnesemia	29 (10.1)	18 (6.3)	47 (8.2)
Decreased appetite	25 (8.7)	14 (4.9)	39 (6.8)
Hyponatremia	12 (4.2)	19 (6.6)	31 (5.4)
Hypophosphatemia	22 (7.6)	9 (3.1)	31 (5.4)
Hypocalcemia	15 (5.2)	13 (4.5)	28 (4.9)
Respiratory, thoracic and mediastinal disorders	141 (49.0)	108 (37.6)	249 (43.3)
Cough	30 (10.4)	24 (8.4)	54 (9.4)
Dyspnea	29 (10.1)	25 (8.7)	54 (9.4)
Epistaxis	32 (11.1)	17 (5.9)	49 (8.5)
Investigations	125 (43.4)	116 (40.4)	241 (41.9)
Transaminases increased	53 (18.4)	50 (17.4)	103 (17.9)
Blood alkaline phosphatase increased	21 (7.3)	29 (10.1)	50 (8.7)
Bilirubin increased	24 (8.3)	21 (7.3)	45 (7.8)
Blood lactate dehydrogenase increased	13 (4.5)	18 (6.3)	31 (5.4)
Gamma-glutamyltransferase increased	15 (5.2)	15 (5.2)	30 (5.2)
Platelet count decreased	15 (5.2)	11 (3.8)	26 (4.5)
Blood and lymphatic system disorders	96 (33.3)	86 (30.0)	182 (31.7)
Febrile neutropenia	42 (14.6)	38 (13.2)	80 (13.9)
Anemia	26 (9.0)	29 (10.1)	55 (9.6)
Thrombocytopenia	23 (8.0)	18 (6.3)	41 (7.1)
Nervous system disorders	95 (33.0)	78 (27.2)	173 (30.1)
Headache	35 (12.2)	25 (8.7)	60 (10.4)
Dizziness	22 (7.6)	12 (4.2)	34 (5.9)
Skin and subcutaneous tissue disorders	83 (28.8)	79 (27.5)	162 (28.2)
Rash	28 (9.7)	30 (10.5)	58 (10.1)
Psychiatric disorders	58 (20.1)	70 (24.4)	128 (22.3)
Insomnia	18 (6.2)	16 (5.6)	34 (5.9)
Hallucination	6 (2.1)	15 (5.2)	21 (3.7)
Confusional state	10 (3.5)	16 (5.6)	26 (4.5)
Musculoskeletal and connective tissue disorders	68 (23.6)	57 (19.9)	125 (21.7)
Pain in extremity	19 (6.6)	13 (4.5)	32 (5.6)
Arthralgia	18 (6.2)	9 (3.1)	27 (4.7)
Vascular disorders	59 (20.5)	60 (20.9)	119 (20.7)
Hypertension	28 (9.7)	23 (8.0)	51 (8.9)
Hypotension	20 (6.9)	19 (6.6)	39 (6.8)
Renal and urinary disorders	71 (24.7)	47 (16.4)	118 (20.5)
Acute kidney injury	18 (6.2)	12 (4.2)	30 (5.2)
Cardiac disorders	47 (16.3)	52 (18.1)	99 (17.2)
Tachycardia	11 (3.8)	18 (6.3)	29 (5.0)
Eye disorders	35 (12.2)	48 (16.7)	83 (14.4)
Visual impairment	14 (4.9)	21 (7.3)	35 (6.1)
Hepatobiliary disorders	39 (13.5)	26 (9.1)	65 (11.3)
Hepatic function abnormal	15 (5.2)	8 (2.8)	23 (4.0)
Neoplasms benign, malignant and unspecified (incl cysts and polyps)	32 (11.1)	31 (10.8)	63 (11.0)
Acute leukemia	16 (5.6)	17 (5.9)	33 (5.7)

Version date: October 12, 2018

NDA Multi-disciplinary Review and Evaluation, sNDA 205596, 205053, 214770
 NOXAFIL® (posaconazole) injection, delayed release tablet, PowderMix
 For prophylaxis of invasive fungal infections in pediatric patients 2 years of age and older
 For treatment of invasive aspergillosis in adults and pediatric patients 13 years and older

	Posaconazole (N=288) n/N(%)	Voriconazole (N=287) n/N%	Total (N=575) n/N%
No. patients with at least 1 TEAE	281 (97.6)	280 (97.6)	561 (97.6)

Source: OCS Analysis Studio, Custom Table Tool.

Columns - Dataset: Demographics; Filter: TRTFL = 'Y'. ADAE2

Table Section 1 - Dataset: Adverse Events; Filter: TRTEMFL = 'Y'; Percent Threshold: >= 5%.

Selected preferred terms were pooled as follows: Anemia includes: anemia, anemia macrocytic, aplastic anemia, hypochromic anemia. Rash includes: rash, rash erythematous, rash macular, rash maculopapular, rash papular, rash pruritic, rash vesicular, (*genital rash and injection site rash were excluded*). Pneumonia includes: pneumonia, atypical pneumonia, *Enterobacter* pneumonia, pneumocystis jerevecii, pneumonia aspiration, pneumonia bacterial, pneumonia fungal, pneumonia influenza, pneumonia *Klebsiella*, pneumonia RSV, pneumonia staphylococcal, pneumonia viral. Abdominal pain includes: abdominal pain, abdominal pain upper, abdominal pain lower; Transaminases increased includes: transaminases increased, alanine aminotransferases increased, aspartate aminotransferases increased; Visual impairment includes: visual impairment, visual acuity reduced, vision blurred. Acute Leukemia includes: acute leukemia, acute lymphocytic leukemia, acute lymphocytic leukemia recurrent, acute myeloid leukemia, acute myeloid leukemia recurrent.

TEAEs occurring in at least 10% of patients are summarized in Table 10-33. The most frequently reported AEs with an incidence >15% were:

- POS treatment group: hypokalemia, pyrexia, nausea, ALT/AST increased, vomiting, diarrhea, and pneumonia.
- VOR treatment group: pyrexia, nausea, hypokalemia, diarrhea, and ALT/AST increased.

TEAEs occurring at ≥ 10% of patients in the POS and with an incidence rate of ≥ 2% higher than the VOR group included the following TEAEs: hypokalemia (28.5% vs. 17.1%), pyrexia (28.1% vs. 25.1%), nausea (22.6% vs. 17.8%), vomiting (18.1% vs. 13.6%), headache (12.2% vs. 8.7%), constipation (11.1% vs. 8.0%), epistaxis (11.1% vs. 5.9%), increased bilirubin (11.1% vs. 9.1%) hypomagnesemia (10.1% vs. 6.3%), and cough (10.4% vs. 8.4%), respectively.

Selected preferred terms (PTs) in the Investigations SOC were pooled by the reviewer to provide a more accurate comparison of the incidence of hepatic TEAEs, for example, the incidence of increased transaminases (pooled PTs: ALT increased, AST increased, transaminases increased) was similar in the treatment groups, [POS, 53 patients (18.4%) vs. VOR, 50 patients (17.4%)].

Overall, the frequency and types of TEAEs were similar between the two treatment groups except for a significant difference in the proportion of patients who developed hypokalemia in the POS group, [POS (28.5%) vs. VOR (17.1%)].

Version date: October 12, 2018

Table 10-33 Study P069: Treatment Emergent Adverse Events occurring at rate ≥ 10% - Safety Population

	Posaconazole (N=288)	Voriconazole (N=287)	Total (N=575)
No. patients with at least 1 TEAE	281 (97.6)	280 (97.6)	561 (97.6)
Hypokalemia	82 (28.5)	49 (17.1)	131 (22.8)
Pyrexia	81 (28.1)	72 (25.1)	153 (26.6)
Nausea	65 (22.6)	51 (17.8)	116 (20.2)
Transaminases increased	53 (18.4)	50 (17.4)	103 (17.9)
Diarrhea	52 (18.1)	52 (18.1)	104 (18.1)
Vomiting	52 (18.1)	39 (13.6)	91 (15.8)
Pneumonia	49 (17.0)	43 (15.0)	92 (16.0)
Febrile neutropenia	42 (14.6)	38 (13.2)	80 (13.9)
Abdominal pain	37 (12.8)	36 (12.5)	73 (12.7)
Headache	35 (12.2)	25 (8.7)	60 (10.4)
Bilirubin increased	32 (11.1)	26 (9.1)	58 (10.1)
Constipation	32 (11.1)	23 (8.0)	55 (9.6)
Epistaxis	32 (11.1)	17 (5.9)	49 (8.5)
Edema peripheral	32 (11.1)	24 (8.4)	56 (9.7)
Cough	30 (10.4)	24 (8.4)	54 (9.4)
Dyspnea	29 (10.1)	25 (8.7)	54 (9.4)
Hypomagnesemia	29 (10.1)	18 (6.3)	47 (8.2)
Rash	28 (9.7)	30 (10.5)	58 (10.1)
Anemia	26 (9.0)	29 (10.1)	55 (9.6)
Blood alkaline phosphatase increased	21 (7.3)	29 (10.1)	50 (8.7)

Source: OCS Analysis Studio, Custom Table Tool.

Columns - Dataset: Demographics; Filter: TRTFL = 'Y'.

Table Section 1 - Dataset: Adverse Events; Filter: TRTEMFL = 'Y'; Percent Threshold: >= 10%.

*Transaminases increased: transaminases increased, alanine aminotransferases increased, aspartate aminotransferases increased;**Pneumonia: pneumonia, atypical pneumonia, Enterobacter pneumonia, pneumocystis jirovecii, pneumonia aspiration, pneumonia bacterial, pneumonia fungal, pneumonia influenza, pneumonia Klebsiella, pneumonia RSV, pneumonia staphylococcal, pneumonia viral.**Rash: rash, rash erythematous, rash macular, rash maculopapular, rash papular, rash pruritic, rash vesicular (genital rash and injection site rash were excluded). Anemia: anemia, anemia macrocytic, aplastic anemia, hypochromic anemia.*

Clinical reviewer's comment: Most of patients (97%) in both treatment groups experienced a TEAE as would be expected in a clinical trial of critically ill patients with invasive aspergillosis.

Hypokalemia was the most common TEAE in the POS group and occurred more frequently than the VOR group. Electrolyte abnormalities such as hypokalemia are common in hospitalized patients due to underlying clinical conditions such as diarrhea, chronic renal disease, intravenous hydration, and medications such as diuretics; therefore, an attribution to POS is challenging to assess. Hypokalemia was associated with POS treatment in the phase 3 registrational trials for prophylaxis of IFI and hypokalemia is listed as an adverse reaction in the approved NOXAFIL USPI. The Warnings and Precautions section of the approved NOXAFIL® USPI states that electrolyte disturbances, especially those involving potassium, magnesium, or calcium levels, should be monitored and corrected as necessary before and during POS therapy.

TEAE Risk Assessment

Version date: October 12, 2018

Error! Reference source not found. summarizes the relative risk assessment for TEAEs in the POS versus VOR treatment groups. Significant differences in the relative risk of TEAEs in each body system organ class (SOC) unfavorable to POS were observed for Metabolism and Nutrition, Renal / Urinary and Respiratory/Thoracic/Mediastinal Disorders.

In the Metabolism/ Nutrition Disorders, hypokalemia and hypophosphatemia were more common in the POS group and accounted for most of the differences between treatment groups: hypokalemia [POS, 82 patients (29.1%) vs. VOR, 49 patients (17.4%)] and hypophosphatemia [POS, 22 patients (7.8%) vs. VOR, 9 patients (3.2%)].

In the Respiratory /Thoracic/Mediastinal Disorders, the number of patients with epistaxis contributed to the differences observed between the treatment groups, [POS, 32 patients (11.4%) vs. VOR, 17 patients (6%)]. Thrombocytopenia was also more common in the POS group, [POS 24 (8.5%) vs. VOR 21 (7.5%)], and may have been associated with the greater number of events of epistaxis in the POS group. Within the Renal and Urinary Disorders, more patients in the POS group had a TEAE of acute kidney injury [POS, 18 (6.2%) vs. VOR, 12 (4.2%)]. Renal abnormalities are further discussed in Laboratory Findings (10.2.8).

Figure 10-2 Study P069: Safety Risk Assessment for TEAEs in Safety Population

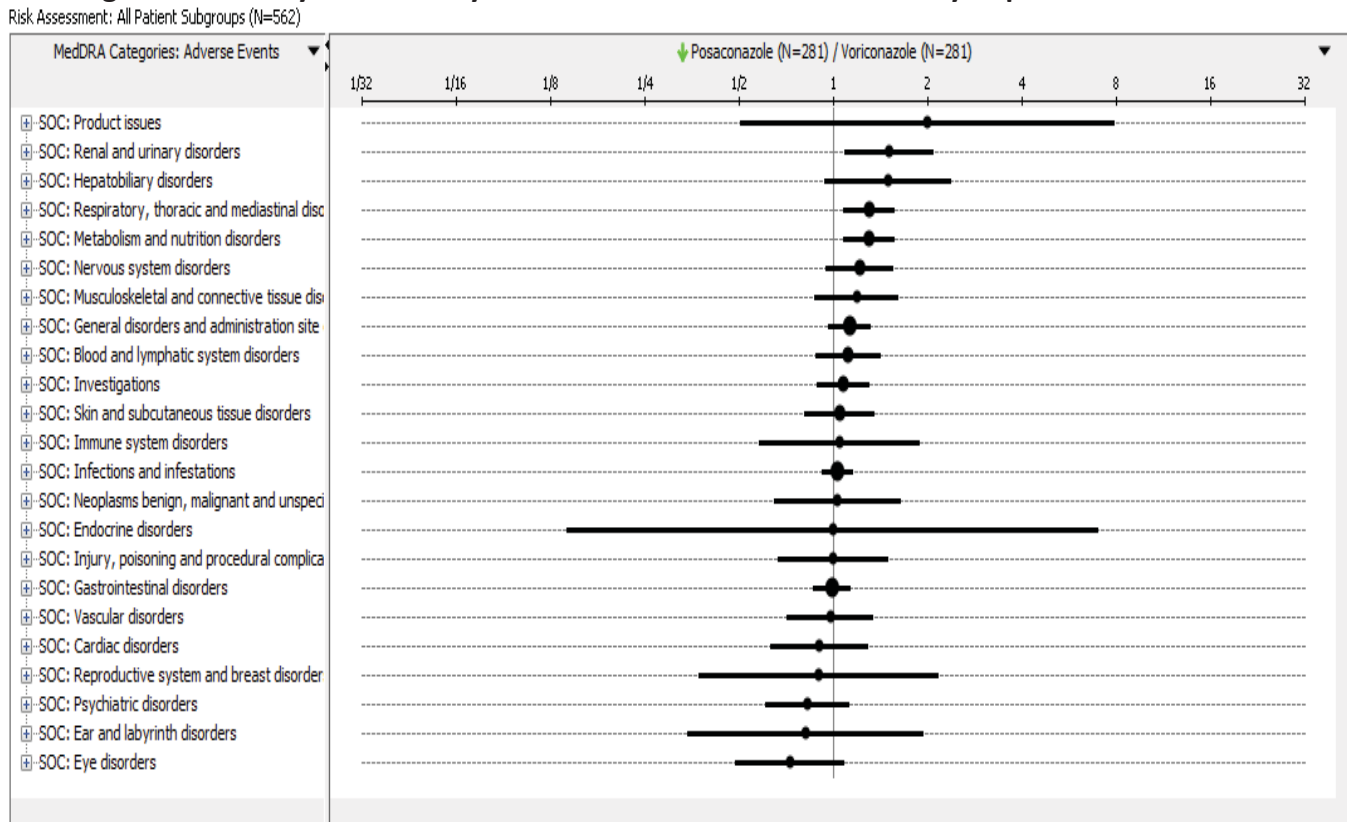

Source: JReview v13.2. Study MK-5592-069, ADAE dataset.

Outcomes of Treatment Emergent Adverse Events

Version date: October 12, 2018

Outcomes of TEAEs for patients in the trial are summarized in Table 10-34. An individual patient may be represented in more than one outcome category in the table. A marginally larger proportion of patient in the POS group had TEAEs that were not recovered; however, overall, the proportions of patients with TEAEs that were fatal, recovered, recovering, or not recovered were comparable between the two treatment groups.

Table 10-34 Study P069: Outcome Status of TEAEs in Study Subjects

Outcome category of TEAE	Posaconazole IV and / or Posaconazole Tablet Oral (N=288)	Voriconazole IV and / or Voriconazole Tablet Oral (N=287)	Total (N=575)
RECOVERED/RESOLVED	263 (91.3)	258 (89.9)	521 (90.6)
NOT RECOVERED/NOT RESOLVED	142 (49.3)	132 (46.0)	274 (47.7)
FATAL	86 (29.9)	87 (30.3)	173 (30.1)
RECOVERING/RESOLVING	47 (16.3)	65 (22.6)	112 (19.5)
RECOVERED/RESOLVED WITH SEQUELAE	28 (9.7)	21 (7.3)	49 (8.5)
UNKNOWN	20 (6.9)	30 (10.5)	50 (8.7)
No data / Missing data	2 (0.7)	5 (1.7)	7 (1.2)

Source: OCS Analysis Studio, Custom Table Tool.

Columns - Dataset: Demographics; Filter: TRTFL = "Y".

TEAEs - Dataset: Adverse Events; Filter: TRTEMFL = "Y". Variable AEOU; A patient may be represented in more than one outcome category.

The outcome status of all reported TEAEs are summarized in Table 10-35. There were no major differences in the proportions of TEAEs that recovered, were recovering, not recovered, or were fatal between the POS and VOR treatment groups.

Table 10-35 Study P069: Outcome Status of TEAEs

Outcome category of TEAE	Posaconazole IV and / or Posaconazole Tablet Oral	Voriconazole IV and / or Voriconazole Tablet Oral	Total
TEAEs, N (%)	3709 (53.1%)	3276 (46.9%)	6985 (100%)
RECOVERED/RESOLVED	2773 (39.7)	2276 (32.6)	5049 (72.3)
NOT RECOVERED/NOT RESOLVED	604 (8.6)	634 (9.1)	1238 (17.7)
FATAL	121 (1.7)	121 (1.7)	242 (3.5)
RECOVERING/RESOLVING	113 (1.6)	161 (2.3)	274 (3.9)
RECOVERED/RESOLVED WITH SEQUELAE	36 (0.5)	29 (0.4)	65 (0.9)
UNKNOWN	62 (0.9)	55 (0.8)	117 (1.7)

Source: JMP v 15.0.

Columns - Dataset: Demographics; Filter: TRTFL = "Y".

TEAEs - Dataset: Adverse Events; Filter: TRTEMFL = "Y". Variable AEOU;

Drug-Related TEAEs

In Study P069, fewer POS -treated patients experienced drug-related TEAEs as compared to the VOR-treated group, [POS 29.9% vs. VOR 40.1% (-10.2%; 95% CI: -17.9, -2.4)] as assessed by the investigators, Table 10-36. The most common drug-related TEAEs reported in >5% of subjects in both treatment groups were increased aminotransferases, [POS (9.0%) vs. VOR (7.7%)]. A larger proportion of patients in the POS group had drug-related hypokalemia, [POS (3.8%) vs. VOR (0.3%)].

Fewer POS-treated subjects reported drug-related AEs in the Eye disorders and Psychiatric disorders

Version date: October 12, 2018

than VOR-treated patients. These disparities were driven by between-group differences in dyschromatopsia (POS 0 vs. VOR 2.1%), visual impairment (POS 1% vs. VOR 5.6%), and hallucination (POS 1.4% vs. VOR 4.2%), each of which was reported at a lower incidence for POS-treated patients compared with VOR-treated patients.

Table 10-36 Study P069: Drug-Related TEAEs

	Posaconazole (N=288) n/N (%)	Voriconazole (N=287) n/N (%)	Total (N=575) n/N (%)
Transaminases increased*	26 (9.0)	22 (7.7)	48 (8.3)
Nausea	12 (4.2)	11 (3.8)	23 (4.0)
Bilirubin increased	11 (3.8)	7 (2.4)	18 (3.1)
Hypokalemia	11 (3.8)	1 (0.3)	12 (2.1)
Vomiting	9 (3.1)	5 (1.7)	14 (2.4)
Blood alkaline phosphatase increased	7 (2.4)	16 (5.6)	23 (4.0)
Gamma-glutamyltransferase increased	5 (1.7)	11 (3.8)	16 (2.8)
Hepatic function abnormal	5 (1.7)	4 (1.4)	9 (1.6)
Hallucination	4 (1.4)	12 (4.2)	16 (2.8)
Blood lactate dehydrogenase increased	4 (1.4)	3 (1.0)	7 (1.2)
Decreased appetite	4 (1.4)	1 (0.3)	5 (0.9)
Diarrhea	4 (1.4)	2 (0.7)	6 (1.0)
Rash†	3 (1.0)	2 (0.7)	5 (0.9)
Visual impairment‡	3 (1.0)	16 (5.6)	19 (3.3)
Abdominal pain	2 (0.7)	5 (1.7)	7 (1.2)
Dizziness	2 (0.7)	3 (1.0)	5 (0.9)
Photopsia	2 (0.7)	6 (2.1)	8 (1.4)
Hallucination, visual	1 (0.3)	5 (1.7)	6 (1.0)
Encephalopathy	1 (0.3)	3 (1.0)	4 (0.7)
Blood urea increased	0	3 (1.0)	3 (0.5)
Constipation	0	3 (1.0)	3 (0.5)
Dyschromatopsia	0	6 (2.1)	6 (1.0)
Headache	0	3 (1.0)	3 (0.5)
Total bile acids increased	0	4 (1.4)	4 (0.7)
Vertigo	0	3 (1.0)	3 (0.5)

Source: OCS Analysis Studio, Custom Table Tool.

Columns - Dataset: Demographics; Filter: TRTFL = 'Y'.

Table Section 1 - Dataset: Adverse Events; Filter: TRTEMFL = 'Y', AEREL = 'RELATED'; Percent Threshold: >= 1%.

Preferred terms were pooled: *Transaminases increased: transaminases increased, alanine aminotransferases increased, aspartate aminotransferases increased; †Rash: rash, rash erythematous, rash macular, rash maculopapular, rash papular, rash pruritic, rash vesicular.

‡Visual impairment: visual impairment, visual acuity reduced, vision blurred.

Clinical reviewer's comment: The overall safety profile of POS and VOR were comparable based on the incidence rates of TEAEs and SAEs during the trial.

1.1.1.5. Dropouts and/or Discontinuations Due to Adverse Effects

Discontinuation of Study Treatment

Version date: October 12, 2018

TEAEs in patients who prematurely discontinued study drugs are summarized in Table 10-37. TEAEs leading discontinuation of POS or VOR were reported for 195 patients (33.9%) during the trial, Day 1 to Day 114. Fewer patients discontinued POS than VOR, [POS, 93 patients (32.3%) vs. VOR, 102 patients (35.5%)]. The incidence of SAEs leading to discontinuation of study drugs was also lower in the POS group as compared to the VOR group, [POS, 76 patients (26.4%) vs. VOR, 82 patients (28.6%)].

Drug-related TEAEs

TEAEs that were considered drug-related by the investigators led to discontinuations of study treatment in 18 patients (6.3%) in the POS group and 28 patients (9.8%) in the VOR group. SAEs that were considered drug-related led to discontinuation of treatment in 10 patients (3.5%) and 14 patients (4.9%) in the POS and VOR groups, respectively.

**Table 10-37 Study P069: TEAEs Resulting in Discontinuation of Study Drugs
(≥ 2 subjects in POS group) - Safety Population**

	Posaconazole (N=288), n/N%	Voriconazole (N=287), n/N%	Total (N=575), n/N%
TEAE leading to drug withdrawn	93 (32.3)	102 (35.5)	195 (33.9)
Septic shock	9 (3.1)	8 (2.8)	17 (3.0)
Respiratory failure	8 (2.8)	2 (0.7)	10 (1.7)
Acute leukemia	7 (2.4)	8 (2.8)	15 (2.6)
Pneumonia	7 (2.4)	10 (3.5)	17 (3.0)
Aspergillosis	6 (2.1)	6 (2.1)	12 (2.1)
Acute kidney injury	4 (1.4)	1 (0.3)	5 (0.9)
Hallucination	3 (1.0)	3 (1.0)	6 (1.0)
Encephalopathy	3 (1.0)	4 (1.4)	7 (1.2)
Atrial fibrillation	2 (0.7)	0	2 (0.3)
Bacterial sepsis	2 (0.7)	1 (0.3)	3 (0.5)
Fungal infection	2 (0.7)	1 (0.3)	3 (0.5)
Hemoptysis	2 (0.7)	0	2 (0.3)
Hepatic function abnormal	2 (0.7)	1 (0.3)	3 (0.5)
Seizure	2 (0.7)	0	2 (0.3)
Sepsis	2 (0.7)	3 (1.0)	5 (0.9)
Transaminases increased	2 (0.7)	4 (1.4)	6 (1.0)
Vomiting	2 (0.7)	0	2 (0.3)

Source: OCS Analysis Studio, Custom Table Tool.

Columns - Dataset: Demographics; Filter: TRTFL = 'Y'.

Dataset: ADAE; Filters: TRTEMFL = 'Y', AEACN = 'DRUG WITHDRAWN'.

*Pooled Preferred terms (PTs) : Pneumonia includes: pneumonia viral, pneumonia bacterial, pneumonia *Klebsiella*, pneumonia fungal, pneumonia cytomegalovirus; Transaminases increased includes: ALT increased, AST increased, transaminases increased); Respiratory failure includes: respiratory failure, acute respiratory failure, acute respiratory distress syndrome, ARDS); Aspergillosis (bronchopulmonary aspergillosis, aspergillus infection); Rash includes: rash, rash maculopapular). Pulmonary Hemorrhage includes: pulmonary alveolar hemorrhage, pulmonary alveolar hemorrhage). Acute leukemia includes: acute leukemia, acute lymphocytic leukemia, acute lymphocytic leukemia recurrent, acute myeloid leukemia, acute myeloid leukemia recurrent.

Clinical Reviewer's Comment: Fewer patients discontinued POS due to an AE than did VOR-treated patients. The discontinuation rates reported in registrational clinical trials of POS delayed-release tablets and POS IV for injection for prophylaxis of IFI were 22% and 18%, respectively, and lower than those

Version date: October 12, 2018

observed in P069. The lower discontinuations rates were probably related to the shorter durations of exposure in the registrational trials (median 28 days) compared to study P069 (median 67 days). The two POS formulations were originally studied separately, one formulation per study, whereas they were studied together in P069; therefore, any direct comparison of discontinuation rates is limited.

1.1.1.6. Significant Adverse Events

Designated Medical Events (DME) are AEs reflecting serious medical conditions that may be related to drugs. An evaluation of reported AEs according to CDER's list of Designated Medical Events (DME) was performed to identify subjects who experienced one of the following: acute pancreatitis, acute respiratory failure, agranulocytosis, anaphylaxis or anaphylactoid reaction, aplastic anemia, blindness, bone marrow depression, deafness, disseminated intravascular coagulation, hemolytic anemia, liver failure, liver necrosis, liver transplant, pancytopenia, renal failure, seizure, Stevens-Johnson syndrome, torsades de pointes, toxic epidermal necrolysis, thrombotic thrombocytopenic purpura, and ventricular fibrillation.

In study P069, there were no major differences in the proportion of patients in the two treatment groups who experienced the following AEs: acute pancreatitis (POS 0 patient, VOR 1 patient), seizure (POS 1, VOR 2), toxic skin eruption (POS 0, VOR 1), acute respiratory failure (POS 10, VOR 7), bone marrow failure (POS 3, VOR 2), pancytopenia (POS 0, VOR 1), and thrombotic thrombocytopenic purpura (POS 1, VOR 1). More patients in the POS group experienced respiratory failure which was associated with pneumonia and not with study drugs. TEAEs of special interest associated with azole drugs are discussed in section 10.3.

1.1.1.7. Treatment Emergent Adverse Events of Special Interest

See section 10.3

1.1.1.8. Laboratory Findings

Laboratory findings were analyzed by comparing post-baseline changes in selected laboratory tests using CTC grading for severity in the POS and VOR treatment groups.

Hepatic Laboratory Abnormalities

Table 10-38 summarizes patients who experienced clinically significant hepatic laboratory abnormalities at any time during the trial. At least one post baseline hepatic test result was available for 98% of patients. A marginally larger proportion of POS-treated patients had post-baseline increases in alanine aminotransferase (ALT) at $\geq 3x$ to $\geq 20x$ ULN and total bilirubin levels $\geq 2x$ ULN. Abnormalities in alkaline phosphatase (ALP) levels were lower in the POS group than in VOR group. Twenty-one patients (3.7%) had laboratory results which met the predetermined criteria for Hy's Law, i.e., ALT or AST $\geq 3x$ ULN and total bilirubin $\geq 2x$ ULN and alkaline phosphatase (ALP) $< 2x$ ULN. The incidence of potential Hy's law cases was comparable across the treatment groups, POS 3.9% vs. VOR 3.5%. Potential Hy's law cases are discussed in section 10.3.2.

Version date: October 12, 2018

NDA Multi-disciplinary Review and Evaluation, sNDA 205596, 205053, 214770
 NOXAFIL® (posaconazole) injection, delayed release tablet, PowderMix
 For prophylaxis of invasive fungal infections in pediatric patients 2 years of age and older
 For treatment of invasive aspergillosis in adults and pediatric patients 13 years and older

Table 10-38 Study P069: Hepatic Laboratory Findings that Met Predetermined Criteria - Safety Population

Criteria	Posaconazole		Voriconazole		Total	
	n/m	(%)	n/m	(%)	n/m	(%)
Subjects in population	288		287		575	
Alanine Aminotransferase						
≥3 x ULN	63/281	(22.4)	52/285	(18.2)	115/566	(20.3)
≥5 x ULN	29/281	(10.3)	25/285	(8.8)	54/566	(9.5)
≥10 x ULN	14/281	(5.0)	9/285	(3.2)	23/566	(4.1)
≥20 x ULN	3/281	(1.1)	2/285	(0.7)	5/566	(0.9)
Aspartate Aminotransferase						
≥3 x ULN	38/281	(13.5)	48/286	(16.8)	86/567	(15.2)
≥5 x ULN	22/281	(7.8)	22/286	(7.7)	44/567	(7.8)
≥10 x ULN	8/281	(2.8)	12/286	(4.2)	20/567	(3.5)
≥20 x ULN	4/281	(1.4)	5/286	(1.7)	9/567	(1.6)
Aminotransferase (ALT or AST)						
≥3 x ULN	70/281	(24.9)	64/286	(22.4)	134/567	(23.6)
≥5 x ULN	31/281	(11.0)	32/285	(11.2)	63/566	(11.1)
≥10 x ULN	15/281	(5.3)	15/285	(5.3)	30/566	(5.3)
≥20 x ULN	4/281	(1.4)	5/285	(1.8)	9/566	(1.6)
Bilirubin						
≥2 x ULN	52/283	(18.4)	42/286	(14.7)	94/569	(16.5)
Alkaline Phosphatase						
≥1.5 x ULN	90/282	(31.9)	121/286	(42.3)	211/568	(37.1)
Aminotransferase (ALT or AST) and Bilirubin						
AT ≥3 x ULN and BILI ≥1.5 x ULN	22/282	(7.8)	22/286	(7.7)	44/568	(7.7)
AT ≥3 x ULN and BILI ≥2 x ULN	16/282	(5.7)	18/286	(6.3)	34/568	(6.0)
Aminotransferase (ALT or AST) and Bilirubin and Alkaline Phosphatase						
AT ≥3 x ULN and BILI ≥2 x ULN and ALP <2 x ULN	11/282	(3.9)	10/286	(3.5)	21/568	(3.7)
n = Number of Subjects with postbaseline test results (or combination of test results from the same day) that met predetermined criteria. m = Number of Subjects with at least one postbaseline test result or combination of test results from the same day. ALP = Alkaline phosphatase; ALT = Alanine aminotransferase; AST = Aspartate aminotransferase; AT = Aminotransferase (ALT or AST); BILI = Bilirubin; ULN = Upper limit of normal range. Treatment phase includes 7 follow-up days after last dose.						

Source: Modified from [Ref. 5.3.5.1: P069MK5592: Table 14.3-27]

Source: Table 14.3-27, Clinical Study Report, MK-5592-069

Clinical reviewer's comment: The incidence of hepatic laboratory abnormalities was comparable between the POS and VOR treatment groups and there was no evidence of an increase in potential Hy's Law cases in the POS group.

Version date: October 12, 2018

NDA Multi-disciplinary Review and Evaluation, sNDA 205596, 205053, 214770
 NOXAFIL® (posaconazole) injection, delayed release tablet, PowderMix
 For prophylaxis of invasive fungal infections in pediatric patients 2 years of age and older
 For treatment of invasive aspergillosis in adults and pediatric patients 13 years and older

Changes in post baseline ALT, total bilirubin, and alkaline phosphatase levels

The following analysis represents changes from baseline to maximum postbaseline values for ALT, AST and total bilirubin level based on CTC grade criteria as conducted by the Applicant, Table 10-39.

Table 10-39: Changes in Liver Test Results from CTC Grade 0, 1, or 2 at Baseline to Grade 3 or 4

Laboratory Parameter	Number (%) of Patients with Change*	
	Posaconazole n/N (%)	Voriconazole n/N (%)
AST	22/281 (8)	21/285 (7)
ALT	29/281(10)	23/282 (8)
Bilirubin	26/280 (9)	25/284 (9)
Alkaline Phosphatase	12/282 (4)	20/284 (7)

*Change from Grade 0 to 2 at baseline to Grade 3 or 4 during the study. These data are presented in the form n/N, where n represents the number of patients who met the criterion as indicated, and N represents the number of patients who had a baseline observation and at least one post-baseline observation.
 N=Number of subjects for a given laboratory test with a baseline value of CTC Grade 0, 1, or 2 and at least one post-baseline value.
 CTC = Common Toxicity Criteria; AST= Aspartate Aminotransferase; ALT= Alanine Aminotransferase.

Source: Applicant analysis dated 5/28/2021

This reviewer conducted additional analyses for liver test postbaseline changes for ALT, total bilirubin, and alkaline phosphatase (multiples of ULN cut-offs). Post baseline changes in ALT, total bilirubin, and alkaline phosphatase levels are summarized in the following tables. Changes in AST levels and are not shown because ALT is a more specific indicator of hepatocellular damage. ALT is present primarily in the liver and is a more specific marker of hepatocellular injury. AST is present in the liver and other organs including cardiac muscle, skeletal muscle, kidney, and brain.¹⁶

Alanine aminotransferase (ALT)

Among patients with ALT levels in the normal range (Grade 0) at baseline, 44 patients (15.7%) experienced maximum post baseline ALT elevations $\geq 3x$ ULN (Grade 2 to Grade 4), with 6.8% of patients experiencing increases at Grade 3 or 4 severity, Table 10-40.

¹⁶ Lawrence S Friedman, Sanjiv Chopra, and Shilpa Grover. Approach to the patient with abnormal liver biochemical and function tests. UpToDate, March 2021.

Version date: October 12, 2018

Table 10-40 Study P069: Posaconazole - Baseline to Maximum Post Baseline Shifts in ALT Level Category

Baseline ALT level category	Posaconazole N=281 Maximum Post Baseline Shifts in ALT IU/mL Level Category				
	Grade 0*: ALT ≥LLN to ≤ULN	Grade 1: ALT >ULN to <3x ULN	Grade 2: ALT ≥3x ULN to <5x ULN	Grade 3: ALT ≥5x ULN to <20x ULN	Grade 4: ALT ≥ 20x ULN
Base Grade 0: ALT ≥LLN to ≤ULN	83 (29.5%)	95 (33.8%)	25 (8.9%)	17 (5.9%)	2 (0.7%)
Base Grade 1: ALT >ULN to <3x ULN	0	28 (10.0%)	11 (3.9%)	12 (4.3%)	1 (0.3%)
Base Grade 2: ALT ≥3x ULN to <5x ULN	0	0	4 (1.4%)	2 (0.7%)	0
Base Grade 3: ALT ≥5x ULN to <20x ULN	0	0	0	0	0

Source: JReview v. 13.2, ADLB dataset.

*ALT values < LLN are included in the post baseline Grade 0 ALT category.

Among patients with ALT levels in the normal range (Grade 0) at baseline, 34 patients (11.9%) experienced maximum post baseline ALT elevations ≥3x ULN (Grade 2 to Grade 4), with 6% of patients experiencing increases at Grade 3 or 4 severity, Table 10-41.

Table 10-41 Study P069: Voriconazole - Baseline to Maximum Post Baseline Shifts in ALT Level Category

Baseline ALT level category	Voriconazole N=285 Maximum Post Baseline Shifts in ALT IU/mL Level Category				
	Grade 0*: ALT ≥LLN to ≤ULN	Grade 1: ALT >ULN to <3x ULN	Grade 2: ALT ≥3x ULN to <5x ULN	Grade 3: ALT ≥5x ULN to <20x ULN	Grade 4: ALT ≥ 20x ULN
Base Grade 0: ALT ≥LLN to ≤ULN	103 (36.1%)	83 (27.9%)	17 (5.9%)	14 (4.9%)	3 (1.0%)
Base Grade 1: ALT >ULN to <3x ULN	0	35 (12.3%)	11 (3.9%)	9 (3.1%)	0
Base Grade 2: ALT ≥3x ULN to <5x ULN	0	0	5 (1.8%)	2 (0.7%)	0
Base Grade 3: ALT ≥5x ULN to <20x ULN	0	1 (0.3%)	0	3 (1.0%)	0

Source: JReview v. 13.2, ADLB dataset. *ALT values < LLN are included in post baseline Grade 0 ALT category.

Total Bilirubin

Among patients with normal total bilirubin levels (Grade 0) at baseline, 48 patients (16.7%) treated with POS experienced elevations in total bilirubin levels at Grade 2 to Grade 4 severity, with 6% of patients experiencing increases at Grade 3 or 4 severity, Table 10-42.

Version date: October 12, 2018

Table 10-42 Study P069: Posaconazole - Baseline to Maximum Post Baseline Shifts in Total Bilirubin Level Category

	Posaconazole IV and / or Posaconazole Solid Oral N = 288 Maximum Post Baseline Shifts in Total Bilirubin mg/dL Level Category				
Baseline Total Bilirubin level category	Grade 0: ≥LLN to ≤ULN	Grade 1: >ULN to ≤1.5x ULN	Grade 2: >1.5x ULN to ≤3x ULN	Grade 3: >3x ULN to ≤10x ULN	Grade 4: >10x ULN
Grade 0: BILI ≥LLN to ≤ULN	160 (55.6%)	31(110.8%)	31(10.8%)	12 (4.2%)	5 (1.7%)
Grade 1: BILI >ULN to ≤1.5 x ULN	2 (0.7%)	9 (3.1%)	7 (2.4%)	2 (0.7%)	0
Grade 2: BILI >1.5 x ULN to ≤3x ULN	0	3(1.0%)	10 (3.5%)	6 (2.1%)	2 (0.7%)
Grade 3: BILI >3x ULN to ≤10x ULN	0	0	0	3 (1.0%)	0

Source: JReview v. 13.2, ADLB dataset.

Among patients with normal total bilirubin levels (Grade 0) at baseline, 38 patients (13.2%) experienced elevations in total bilirubin levels at Grade 2 to Grade 4, with 5.6% of patients experiencing increases at Grade 3 or 4 severity, Table 10-43.

Table 10-43 Study P069: Voriconazole - Baseline to Maximum Post Baseline Shifts in Total Bilirubin Level Category

	Voriconazole IV and / or Voriconazole Solid Oral N = 287 Maximum Post Baseline Shifts in Total Bilirubin mg/dL Level Category				
Baseline Total Bilirubin level category	Grade 0: ≥LLN to ≤ULN	Grade 1: >ULN to ≤1.5x ULN	Grade 2: >1.5x ULN to ≤ 3x ULN	Grade 3: > 3x ULN to ≤10x ULN	Grade 4: >10x ULN
Base Grade 0: ≥LLN to ≤ULN	187(65.4%)	20 (7.0%)	22 (7.7%)	15 (5.2%)	1 (0.3%)
Base Grade 1: >ULN to ≤1.5 ULN	4 (1.7%)	5 (1.7%)	6 (2.1%)	7 (2.4%)	0
Base Grade 2: >1.5x ULN to ≤3x ULN	2(0.3%)	3 (1.0%)	5 (1.7%)	5 (1.7%)	2 (0.7%)
Base Grade 3: >3x ULN to ≤10x ULN	0	0	1 (0.3)	1 (0.3%)	0

Source: JReview v. 13.2, ADLB dataset

Alkaline phosphatase (ALP)

Among patients with normal total ALP levels (Grade 0) at baseline, 7 patients (2.4%) treated with POS experienced elevations in ALP levels at Grade 2 or Grade 3 severity, Table 10-44.

Table 10-44 Study P069: Posaconazole - Baseline to Maximum Post Baseline Shifts in ALP Level Category

	Posaconazole IV and / or Posaconazole Solid Oral N=288 Maximum Post Baseline Shifts in ALP			
	Grade 0: ALP ≥LLN to ≤ULN	Grade 1: ALP >ULN to ≤3x ULN	Grade 2: ALP >3x ULN to ≤5x ULN	Grade 3: ALP >5x ULN to ≤20x ULN

Version date: October 12, 2018

ALP Increase				
Base Grade 0: ALP ≥LLN to ≤ULN	93 (32.3%)	83 (28.8%)	4 (1.4%)	3 (1.0%)
Base Grade 1: ALP >ULN to ≤3x ULN	5 (1.7%)	68 (23.6%)	13 (4.5%)	10 (3.5%)
Base Grade 2: ALP >3x ULN to ≤5x ULN	0 (0.0%)	0 (0.0%)	3 (1.0%)	0 (0.0%)
Base Grade 3: ALP >5x ULN to ≤20x ULN	0 (0.0%)	0 (0.0%)	0 (0.0%)	0 (0.0%)

Source: JReview v. 13.2, ADLB dataset

Among patients with normal ALP levels (grade 0) at baseline, 17 patients (5.9%) treated with VOR experienced elevations in ALP levels at Grade 2 or Grade 3, Table 10-45.

Table 10-45 Study P069: Voriconazole - Baseline to Maximum Post Baseline Shifts in ALP Level Category

	Voriconazole IV and / or Voriconazole Solid Oral n=287 Maximum Post Baseline Shifts in ALP			
	Grade 0: ALP ≥=LLN to ≤=ULN	Grade 1: ALP >ULN to ≤=3x ULN	Grade 2: ALP >3x ULN to ≤=5x ULN	Grade 3: ALP >5x ULN to ≤=20x ULN
ALP Increase				
Base Grade 0: ALP ≥=LLN to ≤=ULN	67 (23.3%)	98 (34.1%)	9 (3.1%)	8 (2.8%)
Base Grade 1: ALP >ULN to ≤=3x ULN	3 (1.0%)	72 (25.1%)	10 (3.5%)	5 (1.7%)
Base Grade 2: ALP >3x ULN to ≤=5x ULN	0	0	2 (0.7%)	10 (3.5%)
Base Grade 3: ALP >5x ULN to ≤=20x ULN	0	0	0	2 (0.7%)

Source: JReview v. 13.2, ADLB dataset

In patients with normal baseline values, post baseline maximum increases to Grade 3 and Grade 4 for ALT, total bilirubin, and alkaline phosphatase were comparable between the POS and VOR groups.

Renal Laboratory Abnormalities

Table 10-46 and Table 10-47 summarize changes in serum creatinine (mg/dL) and glomerular filtration rates (mL/min) during treatment with POS and VOR. Baseline and post baseline creatinine values were available for 283 patients (98.3%) and 286 patients (99.7%) in the POS and VOR treatment groups, respectively. Patients with severe renal impairment (estimated creatinine clearance <20 mL/min) were excluded from the trial. Most patients had a normal creatinine level Grade 0 (creatinine >ULN to 1.5 x ULN) at baseline and shifted to Grade 1 or 2 post baseline. In patients with a normal baseline creatinine, the maximum post baseline shift was to Grade 3 in <5% of patients in both treatment groups.

Version date: October 12, 2018

Table 10-46 Study P069: Baseline to Maximum Post Baseline Shifts in Creatinine* mg/dL

Laboratory Test Parameter	Baseline high CTC grade	Max. High CTC Grade	Posaconazole (N=288); No. of Subjects n=283 (98.3%)	Voriconazole (N=287); No. of Subjects n=286 (99.7%)
Creatinine (mg/dL)	0	0	48 (16.7%)	44 (15.3%)
		1	124 (43.1%)	144 (50.2%)
		2	82 (28.5%)	69 (24.0%)
		3	14 (4.9%)	12 (4.2%)
	1	0	0	1 (0.3%)
		1	8 (2.8%)	3 (1.0%)
		2	1 (0.3%)	5 (1.7%)
		3	1 (0.3%)	0
	2	2	4 (1.4%)	4 (1.4%)
		3	1 (0.3%)	4 (1.4%)

Source: JReview 13.2. ADLB Dataset. *During treatment phase, i.e. Day >0 and Lab date <= Last Dose Date plus 7days

Baseline and post baseline GFR values were available for 120 patients (41.7%) and 124 patients (43.2%) in the POS and VOR treatment groups, respectively. Less than 10% of patients in each treatment group had significant decreases in GFR during the trial. Similar proportions of patients in each treatment groups with a GFR at Grade 2 or higher at baseline had an improvement in GFR post baseline.

Table 10-47 Study P069: Baseline to Maximum Post Baseline Shifts in GFR* mL/min

Laboratory Test Parameter	Baseline GFR Category	Max Acute Kidney Injury (AKI) Stage	Posaconazole IV and / or Posaconazole Solid Oral N=288 (100%)	Voriconazole IV and / or Voriconazole Solid Oral N=287 (100%)
Glomerular Filtration Rate mL/min	Base Stage1: eGFR >=90: Normal or High GFR	Stage 1	51 (17.7%)	50 (17.4%)
		Stage 2	21 (7.3%)	19 (6.6%)
		Stage 3	7 (2.4%)	9 (3.1%)
	Base Stage2: eGFR 60-89: Moderate GFR	Stage 1	11 (3.8%)	18 (6.3%)
		Stage 2	4 (1.4%)	7 (2.4%)
		Stage 3	7 (2.4%)	2 (0.7%)
	Base Stage3a: eGFR 45-59: Moderate GFR	Stage 1	8 (2.8%)	7 (2.4%)
		Stage 2	4 (1.4%)	1 (0.3%)
	Base Stage3b: eGFR 30-44: Moderate GFR	Stage 1	3 (1.0%)	4 (1.4%)
		Stage 2	1 (0.3%)	0 (0.0%)

Version date: October 12, 2018

Laboratory Test Parameter	Baseline GFR Category	Max Acute Kidney Injury (AKI) Stage	Posaconazole IV and / or Posaconazole Solid Oral N=288 (100%)	Voriconazole IV and / or Voriconazole Solid Oral N=287 (100%)
	Base Stage 4: eGFR 15-29: Severe GFR	Stage 1	3 (1.0%)	7 (2.4%)
		Subjects filtered	120 (41.7%)	124 (43.2%)

Source: JReview v. 13.2; ADLB dataset.

Clinical reviewer’s comment: Overall, the proportions of patients with increases in creatinine or decreases in glomerular filtration rates during treatment were comparable between the POS and VOR treatment groups.

POS and VOR are not metabolized by the kidney; however, VOR IV for injection (Vfend) and POS IV (Noxafil) contain (b) (4), sulfobutyl ether β-cyclodextrin (SBECD), which can cause nephrotoxicity. The Noxafil USPI states that POS injection should be avoided in patients with moderate or severe renal impairment (eGFR <50 mL/min), unless an assessment of the benefit/risk to the patient justifies the use of Noxafil injection. In patients with moderate or severe renal impairment (eGFR <50 mL/min), receiving the Noxafil injection, accumulation of the intravenous vehicle, SBECD, is expected to occur. In the Noxafil USPI, no dose adjustment is recommended in renal impairment.

Hematology Laboratory Findings

Selected hematologic laboratory parameters using CTC grading for severity are shown in Table 10-48. The incidence of abnormalities in hemoglobin levels, leukocyte counts, neutrophil counts, and platelet counts at each grade severity were comparable across the treatment groups. Hemoglobin, neutrophil, leukocyte and platelet counts commonly reached CTC Grade 4 on-treatment in patients in both treatment groups.

The evaluation of hematology laboratory shift tables would be unreliable because most of the patients enrolled in the trial had an underlying hematologic malignancy and/or had undergone a hematopoietic stem cell transplant. Changes in hematologic parameters during treatment and adverse reactions such as anemia, leukopenia, neutropenia, or thrombocytopenia reflect the severity of the patients’ underlying hematologic diseases and are also likely related to effects of oncologic drug regimens for treatment of hematologic malignancies.

Version date: October 12, 2018

Table 10-48 Study P069: Hematology Laboratory Findings

Criterion†	Posaconazole		Voriconazole		Total	
	n/m	(%)	n/m	(%)	n/m	(%)
Subjects in population	288		287		575	
HEMATOLOGY						
Hemoglobin (g/dL)						
Grade 1: <LLN - 10.0 g/dL	17/283	(6.0)	28/285	(9.8)	45/568	(7.9)
Grade 2: <10.0 - 8.0 g/dL	103/283	(36.4)	111/285	(38.9)	214/568	(37.7)
Grade 3: <8.0 - 6.5 g/dL	108/283	(38.2)	90/285	(31.6)	198/568	(34.9)
Grade 4: <6.5 g/dL	38/283	(13.4)	37/285	(13.0)	75/568	(13.2)
Grade 1: Increase in >0 - 2 g/dL above ULN or above baseline if baseline is above ULN	1/283	(0.4)	1/285	(0.4)	2/568	(0.4)
Grade 2: Increase in >2 - 4 g/dL above ULN or above baseline if baseline is above ULN	0/283	(0.0)	1/285	(0.4)	1/568	(0.2)
Grade 3: Increase in >4 g/dL above ULN or above baseline if baseline is above ULN	0/283	(0.0)	0/285	(0.0)	0/568	(0.0)
Neutrophils (10⁹/L)						
Grade 1: <LLN - 1.5 x 10 ⁹ /L	12/283	(4.2)	5/281	(1.8)	17/564	(3.0)
Grade 2: <1.5 - 1.0 x 10 ⁹ /L	10/283	(3.5)	15/281	(5.3)	25/564	(4.4)
Grade 3: <1.0 - 0.5 x 10 ⁹ /L	27/283	(9.5)	20/281	(7.1)	47/564	(8.3)
Grade 4: <0.5 x 10 ⁹ /L	156/283	(55.1)	166/281	(59.1)	322/564	(57.1)

Criterion†	Posaconazole		Voriconazole		Total	
	n/m	(%)	n/m	(%)	n/m	(%)
Platelets (10⁹/L)						
Grade 1: <LLN - 75.0 x 10 ⁹ /L	25/284	(8.8)	28/285	(9.8)	53/569	(9.3)
Grade 2: <75.0 - 50.0 x 10 ⁹ /L	14/284	(4.9)	13/285	(4.6)	27/569	(4.7)
Grade 3: <50.0 - 25.0 x 10 ⁹ /L	27/284	(9.5)	26/285	(9.1)	53/569	(9.3)
Grade 4: <25.0 x 10 ⁹ /L	163/284	(57.4)	153/285	(53.7)	316/569	(55.5)
Leukocytes (10⁹/L)						
Grade 1: <LLN - 3.0 x 10 ⁹ /L	17/284	(6.0)	16/285	(5.6)	33/569	(5.8)
Grade 2: <3.0 - 2.0 x 10 ⁹ /L	33/284	(11.6)	20/285	(7.0)	53/569	(9.3)
Grade 3: <2.0 - 1.0 x 10 ⁹ /L	35/284	(12.3)	31/285	(10.9)	66/569	(11.6)
Grade 4: <1.0 x 10 ⁹ /L	138/284	(48.6)	150/285	(52.6)	288/569	(50.6)

Source: Table 14.3-26, Clinical Study Report, Study MK-5592-069

Chemistry Laboratory Findings

The Applicant's tabulated results for chemistry laboratory CTC Grade changes from baseline to worst post baseline results during treatment were reviewed for significant differences between the POS and VOR treatment groups. Laboratory results for blood levels of sodium, potassium, calcium, magnesium, phosphorus, glucose, creatinine alkaline phosphatase, ALT, AST, and bilirubin commonly reached CTCAE Grade 1 or Grade 2 on-treatment for patients in both treatment groups and the incidence of these abnormalities were comparable across the treatment groups. Approximately 4% to 11% of subjects in each treatment group had Grade 3 elevations in alkaline phosphatase, ALT, AST, bilirubin, creatinine, and glucose. Grade 3 decreases in albumin, calcium, and sodium were noted for 7% to 11% of subjects in both treatment groups.

Hypokalemia: The largest difference in the incidence of CTC Grade 3 clinical chemistry abnormalities between treatment groups, was in Grade 3 (< 3.0 to 2.5mEq/L) decreases in potassium levels, (POS 22.6% vs. VOR 10.5%), Table 10-49. The incidence of CTCAE Grade 4 toxicity in clinical chemistry

Version date: October 12, 2018

findings was low at <3% except for life-threatening decreases in potassium levels (< 2.5meq/L) (4.9% in the POS group, 1.7% in the VOR group).

Table 10-49 P069: Potassium levels and CTC Grades

Criterion†	Posaconazole		Voriconazole		Total	
	n/m	(%)	n/m	(%)	n/m	(%)
Potassium (mEq/L)						
Grade 1: >ULN - 5.5 mEq/L	35/283	(12.4)	34/286	(11.9)	69/569	(12.1)
Grade 2: >5.5 - 6.0 mEq/L	12/283	(4.2)	19/286	(6.6)	31/569	(5.4)
Grade 3: >6.0 - 7.0 mEq/L	5/283	(1.8)	8/286	(2.8)	13/569	(2.3)
Grade 4: >7.0 mEq/L	7/283	(2.5)	4/286	(1.4)	11/569	(1.9)
Potassium (mEq/L)						
Grade 1: <LLN - 3.0 mEq/L	99/283	(35.0)	94/286	(32.9)	193/569	(33.9)
Grade 3: <3.0 - 2.5 mEq/L	64/283	(22.6)	30/286	(10.5)	94/569	(16.5)
Grade 4: <2.5 mEq/L	14/283	(4.9)	5/286	(1.7)	19/569	(3.3)

Source: Adapted from Table 14.3-25, Clinical Study report, Study MK-5592-069.

In the POS treatment group, patients with normal levels of potassium at baseline (Grade 0) had a higher incidence of post baseline decreases to grade 3 potassium levels (< 3 -2.5 mmol/L) as compared to the VOR treatment group, POS 14.2% versus VOR 4.9%, Table 10-50.

Table 10-50 Study P069: Laboratory CTC Grade Changes in Potassium from Baseline Levels to Worst during Treatment

Potassium (K ⁺) CTCAE BASELINE GRADE	Post Baseline CTCAE WORSE GRADE	Posaconazole N = 288	Voriconazole N = 287
Base potassium above ULN	Base K+ >ULN	1 (0.3%)	0
	Grade 0: >=LLN - <=ULN	7 (2.4%)	11 (3.8%)
	Grade 2: <LLN-3.0 mmol/L	0 (0.0%)	1 (0.3%)
	Grade 3: <3.0-2.5 mmol/L	1 (0.3%)	2 (0.7%)
Base Grade 0: >=LLN - <=ULN	Base K+ >ULN	1 (0.3%)	0 (0.0%)
	Grade 0: >=LLN - <=ULN	151 (52.4%)	191 (66.6%)
	Grade 2: <LLN-3.0 mmol/L	2 (0.7%)	0 (0.0%)
	Grade 3: <3.0-2.5 mmol/L	41 (14.2%)	14 (4.9%)
	Grade 4: <2.5 mmol/L	11 (3.8%)	6 (2.1%)
Base Grade 2: <LLN - 3.0 mmol/L	Grade 0: >=LLN - <=ULN	32 (11.1%)	37 (12.9%)
	Grade 2: <LLN-3.0 mmol/L	1 (0.3%)	0 (0.0%)
	Grade 3: <3.0-2.5 mmol/L	18 (6.3%)	15 (5.2%)
	Grade 4: <2.5 mmol/L	3 (1.0%)	0
Base Grade 3: <3.0 - 2.5 mmol/L	Grade 0: >=LLN - <=ULN	5 (1.7%)	4 (1.4%)
	Grade 3: <3.0-2.5 mmol/L	7 (2.4%)	3 (1.0%)
	Grade 4: <2.5 mmol/L	1 (0.3%)	0 (0.0%)
Base Grade 4: <2.5 mmol/L	Grade 0: >=LLN - <=ULN	0	1 (0.3%)
	Grade 3: <3.0-2.5 mmol/L	0	1 (0.3%)

Version date: October 12, 2018

Source: JReview v. 13.2, Study MK-5596-069, ADLB dataset.

In summary, laboratory shifts of ≥ 1 toxicity grade occurred in most laboratory parameters and the shifts were comparable between the POS and VOR treatment groups.

Clinical reviewer’s comment: The analyses of laboratory data indicated that hypokalemia was more common in the POS group than in the VOR group. Monitoring of potassium, specifically, and other electrolytes is necessary before and during POS therapy as recommended in the Warnings in the Noxafil USPI. No additional labeling is recommended.

1.1.1.9. Vital Signs

Mean changes in vital sign measurements (i.e., pulse rate and systolic/diastolic blood pressure) from baseline over time were variable, with both treatment groups having decreases and increases in pulse rate and blood pressure over time, Table 10-51 and Table 10-52.

At Week 12, both treatment groups showed small increases in systolic and diastolic blood pressure and small decreases in pulse rate. The proportions of subjects reporting an AE of hypertension in POS (9.7%) and VOR (8%) groups were comparable. There were no drug discontinuations or SAEs related to hypertension.

Table 10-51 Mean Change (SD) in Pulse Rate from Baseline over Time in Treatment Phase for POS and VOR Treatment Groups

Visit	Posaconazole			Voriconazole			Total		
	N	Baseline Mean	Mean Change [†] (SD)	N	Baseline Mean	Mean Change [†] (SD)	N	Baseline Mean	Mean Change [†] (SD)
Pulse Rate (beats/min)									
Baseline	288	90.64		287	88.71		575	89.68	
Day 3	279	90.80	-2.82 (14.47)	279	88.82	0.49 (14.37)	558	89.81	-1.16 (14.50)
Week 1	275	90.48	-3.99 (16.61)	280	88.49	2.29 (16.84)	555	89.47	-0.82 (17.01)
Week 2	240	90.31	-5.59 (16.70)	234	87.21	1.56 (18.40)	474	88.78	-2.06 (17.90)
Week 4	204	89.81	-4.19 (17.87)	190	86.32	-0.33 (17.85)	394	88.12	-2.32 (17.94)
Week 6	179	89.02	-4.45 (16.89)	174	85.31	1.52 (18.23)	353	87.19	-1.50 (17.79)
Week 12	138	88.18	-4.54 (17.49)	130	84.60	-2.92 (15.85)	268	86.44	-3.75 (16.70)

[†] Change Scores are mean change from baseline and are based on the measurements of the subjects who were measured at baseline and the time point assessed.
 Baseline is defined as last value obtained prior to the first dose of study treatment during treatment phase. A baseline and Treatment Value are required for a subject to be counted at a time point.
 Treatment phase includes 7 follow-up days after last dose.
 N = Number of subjects in the treatment group, SD=Standard deviation.

Source: [P069MK5592: adam-ads1; advs]

Source: Table 12-14, Clinical Study Report, Study MK-5592-069

Version date: October 12, 2018

NDA Multi-disciplinary Review and Evaluation, sNDA 205596, 205053, 214770
 NOXAFIL® (posaconazole) injection, delayed release tablet, PowderMix
 For prophylaxis of invasive fungal infections in pediatric patients 2 years of age and older
 For treatment of invasive aspergillosis in adults and pediatric patients 13 years and older

Table 10-52 Study P069: Mean Change (SD) In Blood Pressure from Baseline over Time in Treatment Phase for POS and VOR Treatment Groups

Visit	Posaconazole			Voriconazole			Total		
	N	Baseline Mean	Mean Change† (SD)	N	Baseline Mean	Mean Change† (SD)	N	Baseline Mean	Mean Change† (SD)
Systolic Blood Pressure (mmHg)									
Baseline	288	120.15		287	119.73		575	119.94	
Day 3	278	120.35	1.16 (15.51)	277	119.75	0.52 (15.30)	555	120.05	0.84 (15.40)
Week 1	275	119.77	3.41 (18.35)	281	119.80	-0.49 (18.80)	556	119.79	1.44 (18.66)
Week 2	240	118.92	4.88 (18.06)	237	119.08	1.12 (18.88)	477	119.00	3.01 (18.55)
Week 4	203	118.82	3.96 (17.47)	190	119.73	0.22 (17.78)	393	119.26	2.15 (17.70)
Week 6	181	118.54	4.87 (20.37)	174	119.84	0.20 (18.34)	355	119.18	2.58 (19.51)
Week 12	138	118.60	4.38 (21.77)	130	120.56	2.67 (21.37)	268	119.55	3.55 (21.56)
Diastolic Blood Pressure (mmHg)									
Baseline	288	71.58		287	71.47		575	71.53	
Day 3	278	71.71	-0.27 (12.36)	277	71.48	0.03 (11.95)	555	71.59	-0.12 (12.15)
Week 1	275	71.32	2.20 (13.07)	281	71.50	-0.51 (12.86)	556	71.41	0.83 (13.02)
Week 2	240	71.23	1.37 (12.26)	237	71.40	1.08 (12.63)	477	71.31	1.22 (12.43)
Week 4	203	71.30	2.57 (12.35)	190	72.02	0.96 (12.08)	393	71.65	1.79 (12.23)
Week 6	181	71.18	2.59 (12.63)	174	72.05	1.97 (13.03)	355	71.61	2.28 (12.81)
Week 12	138	71.34	4.28 (14.53)	130	72.39	2.05 (15.46)	268	71.85	3.20 (15.00)

Source: Table 12-14, Clinical Study Report, Study MK-5592-069.

Electrocardiograms (ECGs)

A summary of the mean changes in ECG assessment from baseline over time is presented in Table 10-53. The changes in mean values (msec) for PR interval, RR interval, and QT interval measurements from baseline through Week 12 were slightly longer in the POS group, relative to the VOR group, but overall were comparable between the two treatment groups and not considered clinically significant.

Table 10-53 Study P069: Mean Changes in ECG Assessment from Baseline over Time

Visit	Posaconazole			Voriconazole			Total		
	N	Baseline Mean	Mean Change† (SD)	N	Baseline Mean	Mean Change† (SD)	N	Baseline Mean	Mean Change† (SD)
PR Interval, Aggregate (msec)									
Baseline	271	150.49		264	148.97		535	149.74	
Day 3	239	150.80	2.14 (16.03)	236	148.15	-0.55 (14.89)	475	149.49	0.80 (15.51)
Week 1	234	151.12	3.38 (17.73)	232	148.83	-1.62 (15.59)	466	149.98	0.89 (16.87)
Week 12	70	150.79	0.27 (19.38)	75	151.63	0.00 (15.15)	145	151.22	0.13 (17.26)
RR Interval, Aggregate (msec)									
Baseline	280	693.76		282	711.52		562	702.67	
Day 3	249	694.28	23.78 (101.69)	253	712.96	3.14 (123.45)	502	703.69	13.38 (113.54)
Week 1	243	699.77	52.12 (126.95)	250	716.68	1.96 (155.59)	493	708.34	26.69 (144.26)
Week 12	73	704.75	48.22 (149.92)	78	728.74	18.00 (174.93)	151	717.15	32.61 (163.48)
QT Interval, Aggregate (msec)									
Baseline	272	360.21		265	367.37		537	363.74	
Day 3	233	361.17	6.96 (28.69)	227	369.15	0.90 (34.87)	460	365.11	3.97 (32.00)
Week 1	227	363.08	10.81 (37.98)	227	368.36	0.23 (40.95)	454	365.72	5.52 (39.80)
Week 12	69	363.93	12.12 (44.66)	71	375.24	4.54 (49.64)	140	369.66	8.27 (47.23)

Source: Table 14.3-30, Clinical Study Report, Study MK-5596-069.

QT Interval

Baseline mean QT interval measurements were comparable between the two treatment groups, Table 10-54. POS-treated subjects had a lower incidence of QTc >500 msec and QTc increases from baseline

Version date: October 12, 2018

NDA Multi-disciplinary Review and Evaluation, sNDA 205596, 205053, 214770
 NOXAFIL® (posaconazole) injection, delayed release tablet, PowderMix
 For prophylaxis of invasive fungal infections in pediatric patients 2 years of age and older
 For treatment of invasive aspergillosis in adults and pediatric patients 13 years and older

>60 msec in comparison to VOR-treated subjects.

Table 10-54 Study P069: QT Interval Measurements

Treatment	Criteria	Any QTc		Bazett QTc		Fridericia QTc	
		Count/ Number	(Percent)	Count/ Number	(Percent)	Count/ Number	(Percent)
Posaconazole (N=288)	Change from Baseline ≥ 60 msec†	5/261	(1.9)	4/261	(1.5)	5/261	(1.9)
	Ongoing Cardiac AEs in Subjects with QTc Change ≥ 60 msec	1/5	(20.0)	0/4	(0.0)	1/5	(20.0)
	Treatment Phase Value ≥ 500 msec‡	6/276	(2.2)	6/276	(2.2)	2/276	(0.7)
	Ongoing Cardiac AEs in Subjects with QTc ≥ 500 msec	2/6	(33.3)	2/6	(33.3)	1/2	(50.0)
	Treatment Phase Value ≥ 500 msec and Change from Baseline ≥ 60 msec†	2/261	(0.8)	1/261	(0.4)	1/261	(0.4)
	Males - Treatment Phase Value ≥ 450 msec‡	62/276	(22.5)	61/276	(22.1)	23/276	(8.3)
	Males - Chg from Base ≥ 60 msec and Value ≥ 450 msec†	3/261	(1.1)	3/261	(1.1)	2/261	(0.8)
	Females - Treatment Phase Value ≥ 470 msec‡	18/276	(6.5)	18/276	(6.5)	5/276	(1.8)
	Females - Chg from Base ≥ 60 msec and Value ≥ 470 msec†	1/261	(0.4)	0/261	(0.0)	1/261	(0.4)
	Any Condition Met‡	81/276	(29.3)	80/276	(29.0)	30/276	(10.9)
Voriconazole (N=287)	Change from Baseline ≥ 60 msec†	11/255	(4.3)	11/255	(4.3)	8/255	(3.1)
	Ongoing Cardiac AEs in Subjects with QTc Change ≥ 60 msec	0/11	(0.0)	0/11	(0.0)	0/8	(0.0)
	Treatment Phase Value ≥ 500 msec‡	10/270	(3.7)	10/270	(3.7)	4/270	(1.5)
	Ongoing Cardiac AEs in Subjects with QTc ≥ 500 msec	0/10	(0.0)	0/10	(0.0)	0/4	(0.0)
	Treatment Phase Value ≥ 500 msec and Change from Baseline ≥ 60 msec†	5/255	(2.0)	5/255	(2.0)	3/255	(1.2)
	Males - Treatment Phase Value ≥ 450 msec‡	68/270	(25.2)	66/270	(24.4)	30/270	(11.1)

Treatment	Criteria	Any QTc		Bazett QTc		Fridericia QTc	
		Count/ Number	(Percent)	Count/ Number	(Percent)	Count/ Number	(Percent)
Total (N=575)	Males - Chg from Base ≥ 60 msec and Value ≥ 450 msec†	7/255	(2.7)	7/255	(2.7)	4/255	(1.6)
	Females - Treatment Phase Value ≥ 470 msec‡	20/270	(7.4)	18/270	(6.7)	6/270	(2.2)
	Females - Chg from Base ≥ 60 msec and Value ≥ 470 msec†	2/255	(0.8)	2/255	(0.8)	1/255	(0.4)
	Any Condition Met‡	90/270	(33.3)	86/270	(31.9)	39/270	(14.4)
	Change from Baseline ≥ 60 msec†	16/516	(3.1)	15/516	(2.9)	13/516	(2.5)
	Ongoing Cardiac AEs in Subjects with QTc Change ≥ 60 msec	1/16	(6.3)	0/15	(0.0)	1/13	(7.7)
	Treatment Phase Value ≥ 500 msec‡	16/546	(2.9)	16/546	(2.9)	6/546	(1.1)
	Ongoing Cardiac AEs in Subjects with QTc ≥ 500 msec	2/16	(12.5)	2/16	(12.5)	1/6	(16.7)
	Treatment Phase Value ≥ 500 msec and Change from Baseline ≥ 60 msec†	7/516	(1.4)	6/516	(1.2)	4/516	(0.8)
	Males - Treatment Phase Value ≥ 450 msec‡	130/546	(23.8)	127/546	(23.3)	53/546	(9.7)
	Males - Chg from Base ≥ 60 msec and Value ≥ 450 msec†	10/516	(1.9)	10/516	(1.9)	6/516	(1.2)
	Females - Treatment Phase Value ≥ 470 msec‡	38/546	(7.0)	36/546	(6.6)	11/546	(2.0)
	Females - Chg from Base ≥ 60 msec and Value ≥ 470 msec†	3/516	(0.6)	2/516	(0.4)	2/516	(0.4)

Source: Table 12-15, Clinical Study Report, Study P069-mk5592

1.1.1.10. Immunogenicity

Not applicable.

1.1.1.11. Special Populations

Not applicable.

Version date: October 12, 2018

10.3.5. Analysis of Submission-Specific Safety Issues

1.1.1.12. Treatment Emergent Adverse Events of Special Interest

Adverse reactions known to be associated with POS and other azole antifungal drugs such as hepatotoxicity, central nervous system (CNS) and eye disorders, dermatologic disorders, and abnormalities of adrenal steroidogenesis were prespecified in the clinical trial as adverse events of special interest, and referred to as “Tier 1 events” by the Applicant. TEAEs of special interest are summarized by SOC and preferred terms in Table 15-12 in section 15.4.

The proportions of patients with treatment emergent Tier 1 events are summarized in Table 10-55. The overall incidence of Tier 1 adverse events was similar across the two treatment groups. Central nervous system TEAEs including visual abnormalities occurred in approximately 34% of patients in each treatment group. Other Tier 1 adverse events, i.e. hepatic, dermatologic and adrenal steroidogenesis abnormalities occurred in < 20% of patients in each treatment group.

Table 10-55 Study P069: TEAEs of Special Interest

Treatment Emergent Adverse Events (TEAEs)	POS N =288 (100%); n/N (%)	VOR N = 287 (100%); n/N (%)
Hepatic (potential Hy’s Law cases)*	11 (3.8)	10 (3.5)
CNS and Eye	93 (32.3)	103 (35.9)
Dermatological	47 (16.3)	55 (19.2)
Adrenal steroidogenesis	23 (8.0)	20 (7.0)

Source: Adapted from Table 12-6, CSR. * Hy’s Law criteria: Elevated AST or ALT lab value ≥ 3 x the upper limit of normal (ULN) and an elevated total bilirubin lab value ≥ 2 x ULN and, at the same time, an alkaline phosphatase value < 2 ULN, as determined by protocol specified laboratory testing or unscheduled laboratory testing.

1.1.1.13. Hepatobiliary Adverse Events

Patients who experienced hepatobiliary TEAEs and the subset of patients who were potential Hy’s Law cases are discussed in this section.

Hepatobiliary Disorders

The baseline clinical characteristics of patients in the safety population were reviewed to determine whether there was an imbalance in hepatobiliary disorders; however, no major differences were observed between the two treatment groups. A medical history of hepatobiliary disorders was reported in 69 patients (24%) and 56 patients (19.5%) in the POS and VOR groups, respectively. Twenty-one patients [POS, 8 patients (2.7%) vs. VOR, 13 (4.5%)] had a history of hepatitis B or hepatitis C viral infection. Two patients (0.7%) in the POS group had a history of unspecified hepatitis. Patients with severe hepatic impairment were excluded from the trial.

Hepatobiliary disorders TEAEs were reported in 65 (11.3%) patients and were more common in the POS group, [POS, 39 patients (13.5%) vs. VOR, 26 patients (9.1%)], Table 10-56. Hepatic TEAEs such as ‘hepatic function abnormal’ (increased aminotransferases +/- increased bilirubin) and ‘bilirubin increased’ were the most common TEAEs in the POS group; POS 5.2% vs. VOR 2.8%, and POS 2.8% vs.

Version date: October 12, 2018

NDA Multi-disciplinary Review and Evaluation, sNDA 205596, 205053, 214770
NOXAFIL® (posaconazole) injection, delayed release tablet, PowderMix
For prophylaxis of invasive fungal infections in pediatric patients 2 years of age and older
For treatment of invasive aspergillosis in adults and pediatric patients 13 years and older

VOR 1.7%, respectively. TEAEs such as cholecystitis, cholelithiasis, hepatic cirrhosis, hepatic cyst, hepatic lesion, and hydrocholecystitis (acute distention of the gallbladder) do not appear to have been related to the study drugs.

Selected cases with hepatobiliary TEAEs of interest in the POS treatment group i.e., hepatic failure, jaundice, hepatitis, and liver injury are briefly discussed. Most of the patients remained on POS treatment during these hepatic adverse events and liver tests improved.

Two cases with a TEAE of ‘hepatic failure’ were reported in the POS group. A 19-year-old Asian female with acute myeloid leukemia and prolonged neutropenia developed elevations in total bilirubin with maximum value 2.19 mg/dL (Grade 2, 1.5x to 3x ULN) on Day 13 through 18 of POS treatment; however, aminotransferases and alkaline phosphatase levels remained in the normal ranges. POS was continued and bilirubin levels declined to normal range on POS treatment. The patient received 89 days of POS treatment and completed the trial. The second case was a 60-year-old white male who received an allogeneic HSCT and developed acute graft versus host disease of the GI tract (Day 14 to unknown study day and with hepatic failure on Day 20). The patient received 24 days of POS therapy (Day 1 to 24). He was diagnosed with severe varicella zoster virus (VZV) infection (skin lesions and blood VZV PCR positive) on Day 24 which progressed and POS was stopped for this TEAE. On Day 25 the subject had worsening tachypnea and was diagnosed with pulmonary edema (severe) requiring ICU care. VZV infection was accompanied by worsening of LFTs with rising ALT, AST, total bilirubin, and ALP. He died from disseminated VZV infection on Day 54. A liver biopsy demonstrated hepatic necrosis which was consistent with VZV hepatitis.

The two cases of jaundice included preferred terms, ‘jaundice’ and ‘ocular icterus’. An 83-year-old white male with prolonged neutropenia developed increases in total bilirubin on Day 75 without significant increases in ALT, AST, or alkaline phosphatase levels. He completed 79 days of POS treatment which was discontinued at his death from septic shock on Day 80. The second patient was a 66-year-old white male with a history of prolonged neutropenia who developed elevated total bilirubin levels on day 74 (post treatment period) without significant increases in ALT or AST or alkaline phosphatase. The patient had completed 67 days of POS treatment during which ALT and AST were transiently elevated early during therapy and then returned to normal ranges while on POS treatment. The total bilirubin levels declined toward the normal range and the patient died of a cardiac arrest on Day 78.

Two cases of ‘hepatitis’ were reported. A 21-year-old Asian male with acute lymphocytic leukemia and a history of hepatitis (unspecified) developed transient elevations in ALT, AST, and total bilirubin levels between Day 6 to Day 8. The patient withdrew himself from the study on Day 56. The second case is a 70-year-old Asian male with prolonged neutropenia and a history of chronic hepatitis C who experienced an AE of hepatitis with elevated ALT, AST, and alkaline phosphatase levels) starting on Day 16 (end date not recorded). The patient continued POS and completed 98 days of POS treatment.

Two cases of ‘hepatotoxicity’ were reported. A 35-year-old white male with a history of mediastinal large cell, B-cell lymphoma who developed elevations in hepatic aminotransferases and ALP with a normal bilirubin on Day 14 which resolved on therapy (Day 43), and the patient completed 84 days of POS treatment. The second case was a 24-year-old white male with a prolonged neutropenia and

Version date: October 12, 2018

refractory B-cell lymphoma who developed elevated aminotransferases, bilirubin, and alkaline phosphatase on Day 3 which resolved while on treatment (Day 19). The patient completed 77 days of POS treatment and he died on day 78 due to refractory B-cell lymphoma.

The case of 'liver injury' was a 30-year-old Asian male with acute myeloid leukemia who developed intermittent increases in ALT, AST, bilirubin, and alkaline phosphatase during POS treatment; however, he completed 98 days of treatment with POS and completed the trial.

Table 10-56 Study P069: Hepatobiliary Disorders

TEAE	Posaconazole (N=288), n/N(%)	Voriconazole (N=287), n/N(%)	Total (N=575), n/N(%)
Hepatobiliary disorders	39 (13.5)	26 (9.1)	65 (11.3)
Bilirubin increased	8 (2.8)	5 (1.7)	13 (2.3)
Cholangitis	1 (0.3)	0	1 (0.2)
Cholecystitis	2 (0.7)	3 (1.0)	5 (0.9)
Cholelithiasis	0	1 (0.3)	1 (0.2)
Cholestasis	1 (0.3)	3 (1.0)	4 (0.7)
Hepatic cirrhosis	1 (0.3)	0	1 (0.2)
Hepatic cyst	0	1 (0.3)	1 (0.2)
Hepatic failure	2 (0.7)	0	2 (0.3)
Hepatic function abnormal*	15 (5.2)	8 (2.8)	23 (4.0)
Hepatic lesion	2 (0.7)	0	2 (0.3)
Hepatitis	2 (0.7)	0	2 (0.3)
Hepatocellular injury	0	1 (0.3)	1 (0.2)
Hepatomegaly	1 (0.3)	0	1 (0.2)
Hepatotoxicity	2 (0.7)	3 (1.0)	5 (0.9)
Hydrocholecystis	1 (0.3)	0	1 (0.2)
Jaundice [†]	2 (0.7)	2 (0.7)	4 (0.7)
Liver injury	1 (0.3)	4 (1.4)	5 (0.9)

Source: Analysis Studio, ADLB dataset. Pooled preferred terms: *Hepatic function abnormal includes increased aminotransferases;

[†]Jaundice included PTs: jaundice and ocular icterus;

In the POS treatment group, the outcome status of hepatobiliary TEAEs were categorized as recovered/resolved in 25 patients (8.7%) and not resolved/not recovered in 10 patients (3.5%) at the end of the trial, Table 10-57. This is in comparison to the VOR group, in which 15 patients (5.2%) had TEAEs that resolved and 8 patients (2.8%) had TEAEs which were not resolved.

POS-treated patients experienced more hepatic adverse events than VOR-treated patients, 52 events vs. 37 hepatic adverse events, respectively (table not shown). In the POS group, 39.3% of the hepatic TEAEs had resolved and 13.5% were not resolved by the end of the trial. This is in comparison to the VOR group, in which 23.6% of TEAEs had resolved and 10.1% of TEAEs were not resolved by the end of the trial.

In summary, more patients in the POS group experienced hepatobiliary adverse events than in the VOR group; however, a larger proportion of patients in the POS group had hepatobiliary adverse events that resolved as compared to the VOR group. Overall, there were no major differences in the outcomes of hepatobiliary TEAEs between the two treatment groups.

Version date: October 12, 2018

Table 10-57 Study P069: Outcomes Categories for Hepatobiliary Adverse Events

	Posaconazole (N=288) n/N (%)	Voriconazole (N=287) n/N (%)	Total (N=575) n/N (%)
RECOVERED/RESOLVED	25 (8.7)	15 (5.2)	40 (7.0)
NOT RECOVERED/NOT RESOLVED	10 (3.5)	8 (2.8)	18 (3.1)
RECOVERING/RESOLVING	2 (0.7)	5 (1.7)	7 (1.2)
RECOVERED/RESOLVED WITH SEQUELAE	1 (0.3)	2 (0.7)	3 (0.5)
UNKNOWN	2 (0.7)	0	2 (0.3)
Hepatobiliary Disorders	39 (13.5)	26 (9.1)	65 (11.3)

Source: OCS Analysis Studio, Custom Table Tool.

Columns - Dataset: Demographics; Filter: TRTFL = 'Y'.

Table Section 1 - Dataset: Adverse Events; Filter: TRTEMFL = 'Y', AEBODSYS = 'Hepatobiliary disorders'.

Hepatobiliary Disorders - Dataset: Adverse Events; Filter: AEBODSYS = 'Hepatobiliary disorders', TRTEMFL = 'Y'. A patient may have resolved TEAEs and unresolved TEAEs.

Drug-related hepatobiliary TEAEs

Drug-related hepatobiliary TEAEs occurred in <4% of patients and individual hepatic TEAEs were comparable across the two treatment groups, Table 10-58. There were no cases of hepatic failure or cholestasis related to study drugs. Increases in aminotransferases and total bilirubin levels were the most common drug related TEAEs as determined by the investigator.

Table 10-58 Study P069: Drug-related Hepatic TEAEs

	Posaconazole (N=288), n/N(%)	Voriconazole (N=287), n/N(%)	Total (N=575), n/N(%)
Hepatobiliary Disorders	39 (13.5)	26 (9.1)	65 (11.3)
Hepatobiliary disorders, drug related	9 (3.1)	10 (3.5)	19 (3.3)
Hepatic function abnormal	5 (1.7)	4 (1.4)	9 (1.6)
Bilirubin increased	3 (1.0)	1 (0.3)	4 (0.7)
Cholecystitis	0	1 (0.3)	1 (0.2)
Cholestasis	0	1 (0.3)	1 (0.2)
Hepatocellular injury	0	1 (0.3)	1 (0.2)
Hepatotoxicity	0	1 (0.3)	1 (0.2)
Jaundice	1 (0.3)	0	1 (0.2)
Liver injury	0	1 (0.3)	1 (0.2)

Source: OCS Analysis Studio, Custom Table Tool.

Dataset: Demographics; Filter: TRTFL = 'Y'.

Dataset: Adverse Events; Filter: TRTEMFL = 'Y', AEREL = 'RELATED'.

*Hepatic function abnormal includes increases in aminotransferases;

Adverse events are reported from the first dose of study treatment through 30 days after the last dose.

In most cases, abnormalities in hepatic aminotransferases and total bilirubin levels improved as POS treatment was continued. All cases with hepatic TEAEs had multiple confounders such as complications of underlying malignancies, cancer chemotherapy, and multiple concomitant medications some of which could have contributed to hepatotoxicity. These findings limited the assessment of attribution of hepatic TEAEs to POS; however, POS and other triazoles are known to be associated with hepatotoxicity and an association between hepatotoxicity and POS cannot be ruled out. It is likely that POS contributed to the observed hepatotoxicity.

Version date: October 12, 2018

Hy's Law

Patients whose laboratory results met prespecified criteria for Hy's Law, i.e., ALT or AST \geq 3x ULN and bilirubin \geq 2x ULN and alkaline phosphatase (ALP) $<$ 2x ULN during the treatment phase of the trial are presented in Figure 10-3 and Figure 10-4. The treatment phase is defined from Day 1 of treatment to include 7 days of follow-up after the final dose of study drug.

Alanine aminotransferase

The Hy's plot shows that 10 patients in the POS and in the VOR treatment groups met Hy's Law criteria, Figure 10-3. In the POS and VOR groups, 18 (6.3%) and 21 (7.3%) patients, respectively, had elevated bilirubin suggestive of cholestasis (LUQ of graph). Thirty-one (10.7%) and 23 (8.0%) patients (RLQ), respectively, had elevations in ALT \geq 3x ULN up to 20x ULN with normal bilirubin and ALP levels indicative of hepatocellular injury.

NDA Multi-disciplinary Review and Evaluation, sNDA 205596, 205053, 214770
 NOXAFIL® (posaconazole) injection, delayed release tablet, PowderMix
 For prophylaxis of invasive fungal infections in pediatric patients 2 years of age and older
 For treatment of invasive aspergillosis in adults and pediatric patients 13 years and older

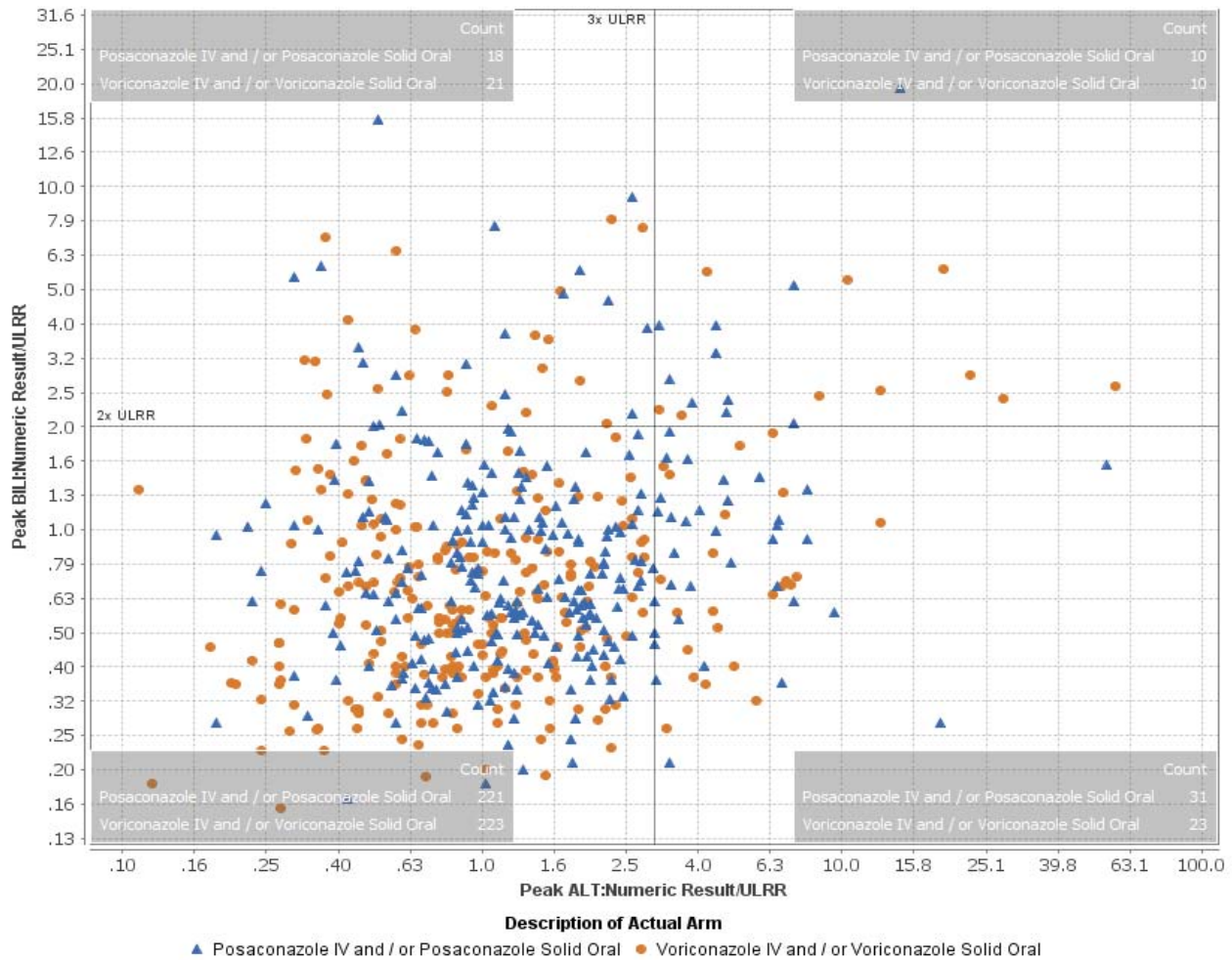

Source: JReview 13.2; Datasets: ADSL, ADLB datasets.

Datapoints in RUQ: Subjects with alanine aminotransferase (ALT) ≥ 3 x ULN and total bilirubin ≥ 2x ULN and alkaline phosphatase < 2x ULN.

*Treatment phase includes 7 days of follow-up after the final dose of study drug.

Figure 10-3 Study P069: Hy's Law Plot during treatment phase* – Safety Population

Aspartate aminotransferase

Five patients (1.7%) in the POS treatment group and 8 patients (2.8%) in the VOR group met Hy's Law criteria, AST ≥ 3 x ULN, total bilirubin ≥ 2x ULN, and alkaline phosphatase < 2x ULN, Figure 10-4.

Version date: October 12, 2018

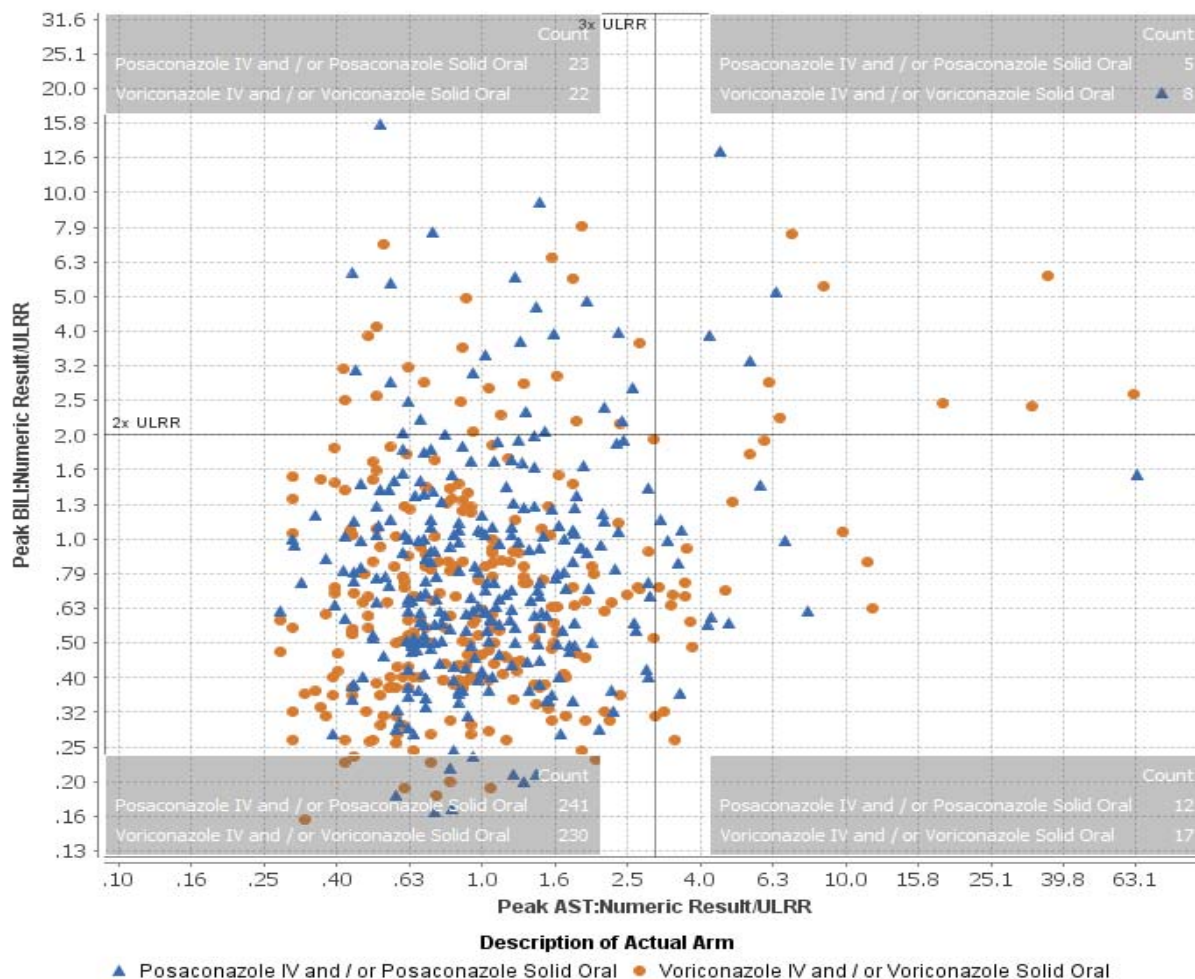

Source: JReview 13.2; Datasets: ADSL, ADLB datasets.

Datapoints in RUQ: Subjects with aspartate aminotransferase AST ≥ 3 x ULN and total bilirubin ≥ 2x ULN and alkaline phosphatase <2x ULN.

*Treatment phase includes 7 days of follow-up after the last dose of study drug.

Figure 10-4 Study P069: Hy's Law Plot during treatment phase* – Safety Population

Potential Hy's Law cases

There was overlap among the patients with an ALT and/or AST ≥ 3x ULN and overall, 21 patients [11 patients (3.8%) in the POS group and 10 patients (3.5%) in the VOR group] had hepatic laboratory test results that met the prespecified criteria for potential Hy's Law cases. The clinical characteristics and outcomes for potential Hy's Law cases are outlined in Table 10-59.

These 21 patients included 8 males and 3 females (16 to 69 years of age) in the POS group and 8 males and 2 females (28 to 70 years of age) in the VOR group. In the POS group, 4 patients completed the trial and 7 patients died. In the VOR group, 1 completed the trial and 9 patients died. Sepsis was a common cause of death in both treatment groups and probably contributed to some of the observed hepatic laboratory abnormalities. No deaths were reported as being related to drug-induced liver injury (DILI).

Among the 11 potential Hy's Law cases (3.8%) in the POS group, 8 patients were reported to have a hepatic TEAE (6 AEs and 2 SAEs); 3 hepatic TEAEs resolved during the trial, 3 TEAEs had not resolved

Version date: October 12, 2018

NDA Multi-disciplinary Review and Evaluation, sNDA 205596, 205053, 214770
NOXAFIL® (posaconazole) injection, delayed release tablet, PowderMix
For prophylaxis of invasive fungal infections in pediatric patients 2 years of age and older
For treatment of invasive aspergillosis in adults and pediatric patients 13 years and older

prior to the patients' deaths and 1 TEAE was partially resolved at the end of POS treatment. In the VOR group, 5 patients had a hepatic TEAE (2 SAEs and three AEs) and none of these adverse events were resolved prior to the patients' deaths. In the POS group, 2 patients had an R factor > 5 indicating hepatocellular injury as compared to 6 patients with R factor > 5 in the VOR group.

In summary, the incidence of hepatic TEAEs was higher in the POS group than in the VOR group. Increases in aminotransferases and total bilirubin levels were the most common drug related TEAEs. There was no evidence of an increase in potential Hy's Law cases for POS compared to VOR with incidence rates of 3.8% and 3.5%, respectively. There were no cases of hepatic failure directly related to the study drugs.

Version date: October 12, 2018

NDA Multi-disciplinary Review and Evaluation, sNDA 205596, 205053, 214770
 NOXAFIL® (posaconazole) injection, delayed release tablet, PowderMix
 For prophylaxis of invasive fungal infections in pediatric patients 2 years of age and older
 For treatment of invasive aspergillosis in adults and pediatric patients 13 years and older

Table 10-59 Study P069: Characteristics of potential Hy’s Law cases in Posaconazole and Voriconazole Groups

	S e x	A g e yrs	R a c e	Study Day (D) of max. ALT/ Total Bilirubin	Phase of Study	Max. ALT, n x ULN	Max. Total Bilirubin, n x ULN	R factor*	Hepatic AE / SAE or other SAE - Study Day of Onset (D)	Outcome of AE or SAE: Resolved/Not resolved	Clinical Comment
POSACONAZOLE											
USUBJID/ Subject ID											
(b) (6)	M	16	M	D 16	F/up 1-day post EOT)	14	21.1	2.9	Hyperbilirubinemia – SAE, D7	Not resolved	POS d/c D15; Death: D16, <i>Klebsiella</i> bacteremia/shock
	M	61	W	D 4	F/up (2 days post EOT)	5	3.5	4.6	Not recorded as hepatic AE; Disseminated Mucormycosis- SAE, D4	Not resolved	Drug d/c Day 3; Death D5, Invasive Aspergillosis/ Mucormycosis
	M	69	W	D 14	Tx	7	5.7	2.0	Not recorded as Hepatic AE. Septic shock- SAE, D14	Not resolved	Death: Septic Shock, D16
	M	69	W	D 27	Tx	3	2.1	1.9	Hepatic function abnormal – AE D27	Resolved D27	Completed POS, D84
	M	21	W	D 7	Tx	5	2.4	2.8	Hyperbilirubinemia – AE, D7	Resolved D8	Completed POS, D 84
	F	25	W	D8	Tx	15	7.7	3.1	Hepatic fn. abnormal -AE onset D4	Resolved D34	POS d/c D16. Death Enterococcal sepsis / aplastic anemia, D62
	M	31	W	D55	Tx	7	11.5	7.1	Incr. bilirubin - AE D45; TTP - AE onset D17; pneumonia - SAE D49; seizure SAE D49	AE improved but not resolved SAEs resolved	POS d/c D49; Other Labs: ALP>2.5 - 5x ULN not resolved; Completed study
	M	41	W	D 46	Tx	10	3.0	3.1	Increased ALT/AST/Bilirubin- AE on D4/ D5/D14)	Not resolved	BILI resolved but ALT /AST remained elevated; POS completed

Version date: October 12, 2018

NDA Multi-disciplinary Review and Evaluation, sNDA 205596, 205053, 214770
 NOXAFIL® (posaconazole) injection, delayed release tablet, PowderMix
 For prophylaxis of invasive fungal infections in pediatric patients 2 years of age and older
 For treatment of invasive aspergillosis in adults and pediatric patients 13 years and older

	S e x	A g e yrs	R a c e	Study Day (D) of max. ALT/ Total Bilirubin	Phase of Study	Max. ALT, n x ULN	Max. Total Bilirubin, n x ULN	R factor*	Hepatic AE / SAE or other SAE - Study Day of Onset (D)	Outcome of AE or SAE: Resolved/Not resolved	Clinical Comment
											to D91
(b) (6)	F	46	W	D19	F/up (8 days post EOT)	3	3.9	1.8	Not recorded as Hepatic AE. Acute kidney injury - SAE D12	Unknown resolution	POS d/c D11; Death: disseminated aspergillosis, D62
	M	65	A	D7	F/up (1 day post EOT)	55	2	80.8	Increased AST/ALT -SAE D7; Pneumonia D7; renal failure, D7;	Not resolved	ALP normal. POS d/c D6; Death: resp. failure D9
	F	46	W	D42	F/up	5	14	1.6	Hepatic fn abn. -AE D42; Incr. bilirubin – AE D27; TTP -SAE onset D25	Hepatic AEs not resolved; SAE not resolved	POS d/c D40; Death: cerebral hemorrhage D43.
	M	70	W	D16	F/up	13	2.5	3.8	Hepatic function abn- SAE D6	Resolved D34	VOR d/c D16; Death: aplastic anemia, D 67
	M	28	W	D8	Tx	57	2.6	53	ALT/AST increased- SAE onset D6; Septic shock-SAE onset D6	Not resolved	VOR d/c D8; Death: multiorgan failure D8
	M	67	AI	D21	F/up	29	13	29.3	Not recorded as hepatic AE; Septic shock -SAE D17	Not resolved	VOR d/c D20; Death: Septic shock D25
	M	36	A	D4	Tx	8	2.4	7.7	Liver injury -AE, D3 Cerebral hem. – SAE, D6	Not resolved	VOR d/c D6 Death: cerebral hem. D6
	M	64	W	D3	Tx	5	3.2	12.5	Resp Failure -SAE, D3	Not resolved	VOR d/c D4; Death: ARDS, D5
	F	43	A	D4	Tx	4	2	2.4	Viral Pneumonia -SAE, D6	Not resolved	VOR d/c 67; Death viral pneumonia, D68
	F	38	W	D13	Tx	7 (AST)	7.5	1.9	No hepatic AE/SAE reported	-	VOR d/c D45. AST resolved D28; total increased bilirubin resolved

Version date: October 12, 2018

NDA Multi-disciplinary Review and Evaluation, sNDA 205596, 205053, 214770
 NOXAFIL® (posaconazole) injection, delayed release tablet, PowderMix
 For prophylaxis of invasive fungal infections in pediatric patients 2 years of age and older
 For treatment of invasive aspergillosis in adults and pediatric patients 13 years and older

	S e x	A g e yrs	R a c e	Study Day (D) of max. ALT/ Total Bilirubin	Phase of Study	Max. ALT, n x ULN	Max. Total Bilirubin, n x ULN	R factor*	Hepatic AE / SAE or other SAE - Study Day of Onset (D)	Outcome of AE or SAE: Resolved/Not resolved	Clinical Comment
											D46
(b) (6)	M	69	W	D7	Tx	4	5.5	8.9	Septic shock -SAE, D6	Not resolved	VOR d/c D7; Death: septic shock D7
	M	40	W	D16	Tx	9	2.5	17	Incr. bilirubin – AE, D14; Bacterial sepsis -SAE, D14	Not resolved	VOR d/c D16; Death: sepsis, D16
	M	46	W	D9	Tx	4	2.7	3.7	Incr. aminotransferase/ bilirubin – AE, D7; <i>Candida</i> sepsis – SAE, D10	Not resolved	VOR d/c D14; Death: <i>Candida</i> sepsis, D14

Source: Table incorporates data from Applicant’s information amendment dated 02/24/21 and from CSR line listings of laboratory data, section 16.2.8.1.16

*The first laboratory values (ALT and ALP) meeting Tier 1 criteria in the CSR line listing were used by the Applicant to calculate the R factor.

D: Day; F: female; M: male; W: White; A: Asian; AL: American Indian/ Alaskan native Indian; Tx: treatment phase; F/UP: follow-up phase; POS: posaconazole; VOR: voriconazole; EOT: end of treatment; AE: adverse event; SAE: serious adverse event; ALT: alanine aminotransferases; AST: aspartate aminotransferases; Bili: Total bilirubin; ALP: alkaline phosphatase; abn: abnormality; fn: function; hem: hemorrhage; incr.: increased, TTP: thrombotic thrombocytopenic purpura.

Version date: October 12, 2018

Clinical reviewer's comment: The incidence of hepatobiliary disorders was higher in the POS group as compared to the VOR group. The incidence of drug-related hepatobiliary disorders was similar between the two treatment groups. There was no evidence of an increase in potential Hy's Law cases for POS as compared to VOR, and there were no cases of fatal hepatic injury due to study drugs in the trial. In this severely-ill population, attribution of the hepatic laboratory abnormalities and other hepatic adverse events to POS or VOR was confounded by several factors which could have contributed to hepatotoxicity such as underlying malignancy, multiple concomitant drugs including cancer chemotherapy, and sepsis due to bacterial and fungal pathogens. However, hepatotoxicity may have been exacerbated by the study drugs as triazoles are known to cause hepatocellular injury.

In the registrational clinical trials of POS formulations for prophylaxis of invasive fungal infections (IFI), and similarly in this phase 3 trial, abnormalities in hepatic laboratory tests were generally reversible on discontinuation of POS therapy, and in some instances these hepatic parameters normalized during continuation of treatment. See clinical reviews for NDA 22003 (oral suspension) approved 09/25/2006, NDA 205053 (delayed release tablets) approved 11/25/2013 and NDA 205596 (IV injection) approved 3/3/2014.

The longer exposures to POS in Study P069 (median 67 days) was not associated with an increase in the severity of hepatic adverse reactions as compared to trials with the shorter durations of exposure (median 28 days) in the non-comparative, pharmacokinetic, and safety registrational trials of POS IV injection and POS delayed-release tablets for IFI prophylaxis. The patient populations in Study P069 and the registrational prophylaxis trials had similar underlying conditions including hematological malignancies, neutropenia post-chemotherapy, GVHD, and HSCT which allows for general comparisons to be made across the trials.

The posaconazole (Noxafil) USPI, includes a warning for hepatic toxicity (e.g., mild to moderate elevations in alanine aminotransferase (ALT), aspartate aminotransferase (AST), alkaline phosphatase, total bilirubin, and/or clinical hepatitis). The Warnings indicates that hepatic laboratory abnormalities were generally reversible on discontinuation of POS therapy. Severe hepatic reactions including cholestasis or hepatic failure including deaths have been reported in patients with serious underlying medical conditions during treatment with POS. Hepatic function abnormal, hepatomegaly, jaundice, bilirubinemia, and hepatitis are listed as adverse reactions in the current Noxafil USPI. No dose adjustment of Noxafil is needed in patients with mild to severe hepatic impairment (Child-Pugh Class A, B, or C). The Applicant has included a table of adverse reactions for Study P069 in the revised draft of the Noxafil label. No additional labeling changes related to hepatic adverse reactions are recommended.

Other TEAEs of special interest

Version date: October 12, 2018

TEAEs of special interest associated with the azole drug class in the CNS/Eye, Skin/Soft Tissue, and Endocrine SOCs are summarized in Table 15-12 in section 15.4. The overall incidence of TEAEs in these SOCs was lower in the POS group than the comparator [POS, 131 patients (45.5%) and VOR, 141 patients (49.1%)].

Drug-related TEAEs of special interest

Table 10-60 summarizes drug-related TEAEs of special interest, as determined by the investigator within the Eye (POS 1.7% vs. VOR 9.4%), Psychiatric (POS 2.1% vs. VOR 4.3%), Nervous system (POS 2.4% vs. VOR 3.5%), Skin/Soft Tissue (POS 1.5% vs. VOR 3.5%), Endocrine (POS 0.2% vs 0) and Vascular (POS 0.2% vs. 0) disorders.

Table 10-60 Study P069: Drug-related TEAEs of Special Interest - Eye, Psychiatric, Endocrine, Neurologic, Skin/Soft Tissue and Vascular Disorders

TEAE (Tier 1 Category)	Posaconazole (N=288), n/N(%)	Voriconazole (N=287), n/N(%)	Total (N=575), n/N(%)
Subjects with at least 1 drug related TEAE	20 (6.9)	54 (18.8)	74(12.9)
Eye disorders	5 (1.7)	27 (9.4)	32 (5.6)
Visual impairment	3 (1.0)	16 (5.6)	19 (3.3)
Photopsia	2 (0.7)	6 (2.1)	8 (1.4)
Dyschromatopsia	0	6 (2.1)	6 (1.0)
Vitreous floaters	0	2 (0.7)	2 (0.3)
Choroidal sclerosis	1 (0.3)	0	1 (0.2)
Pupils unequal	0	1 (0.3)	1 (0.2)
Psychiatric disorders	6 (2.1)	19 (6.6)	25 (4.3)
Hallucination	4 (1.4)	12 (4.2)	16 (2.8)
Hallucination visual	1 (0.3)	5 (1.7)	6 (1.0)
Confusional state	1 (0.3)	2 (0.7)	3 (0.5)
Agitation	0	1 (0.3)	1 (0.2)
Depression	0	1 (0.3)	1 (0.2)
Mental status changes	0	1 (0.3)	1 (0.2)
Nightmare	1 (0.3)	0	1 (0.2)
Nervous system disorders	7 (2.4)	10 (3.5)	17 (3.0)
Dizziness	2 (0.7)	3 (1.0)	5 (0.9)
Encephalopathy	1 (0.3)	3 (1.0)	4 (0.7)
Seizure	2 (0.7)	0	2 (0.3)
Cerebral disorder	0	1 (0.3)	1 (0.2)
Cognitive disorder	1 (0.3)	0	1 (0.2)
Depressed level of consciousness	1 (0.3)	0	1 (0.2)
Dyskinesia	0	1 (0.3)	1 (0.2)
Paraesthesia	0	1 (0.3)	1 (0.2)
Speech disorder	0	1 (0.3)	1 (0.2)
Tremor	0	1 (0.3)	1 (0.2)
Skin and subcutaneous tissue disorders	4 (1.4)	10 (3.5)	14 (2.4)
Rash	3 (1.0)	2 (0.7)	5 (0.9)
Erythema	0	2 (0.7)	2 (0.3)
Toxic skin eruption	0	2 (0.7)	2 (0.3)
Angioedema	0	1 (0.3)	1 (0.2)

Version date: October 12, 2018

TEAE (Tier 1 Category)	Posaconazole (N=288), n/N(%)	Voriconazole (N=287), n/N(%)	Total (N=575), n/N(%)
Dermatitis exfoliative generalized	1 (0.3)	0	1 (0.2)
Photosensitivity reaction	0	1 (0.3)	1 (0.2)
Skin exfoliation	0	1 (0.3)	1 (0.2)
Urticaria	0	1 (0.3)	1 (0.2)
Endocrine disorders	1 (0.3)	0	1 (0.2)
Adrenal insufficiency	1 (0.3)	0	1 (0.2)
Vascular disorders	1 (0.3)	0	1 (0.2)
Hypotension	1 (0.3)	0	1 (0.2)

Source: OCS Analysis Studio, Custom Table Tool.

Columns - Dataset: Demographics; Filter: TRTFL = 'Y'.

Table Section 1 - Dataset: Adverse Events; Filter: TRTEMFL = 'Y', TIER1FL = 'Y', AEREL = 'RELATED'. Rash includes: rash erythematous, rash macular, rash maculopapular, rash papular, rash vesicular and rash pruritic; Visual impairment includes vision blurred, visual acuity reduced, visual impairment. Adverse events are reported from the first dose of study treatment through 30 days after the last dose.

1.1.1.14. Central Nervous System Adverse Events

Approximately one-third of subjects in each treatment group experienced an AE in the Tier-1 CNS and visual safety category (i.e., pre-specified PTs in the SOCs of Eye disorders, Nervous System disorders, and Psychiatric disorders. TEAEs of 'seizure', 'visual hallucinations', and 'hallucinations' are not included in the Noxafil USPI and were selected for further analysis.

Nervous System Disorders

No significant treatment differences were observed in the incidence of Tier-1 AEs associated with Nervous System disorders (POS: 20.8%; VOR: 18.5%). The most reported TEAE was dizziness [POS, 22 patients (7.6%) vs. VOR, 12 patients (4.2%)], Table 15-12.

Seizure: Three patients (1.0%) in the POS group and 5 patients (1.7%) in the VOR- group experienced seizures. Drug-related seizures occurred in 2 patients in the POS group compared to zero patients in the VOR group per the investigators' assessments.

In the POS group, narratives for the 3 patients who experienced a seizure were reviewed and graphical patient profiles (JReview) were constructed for each patient to examine the timeline of occurrence of seizure in relation to study drug, clinical status, and concomitant medications.

Patient 1 (drug-related): A 31-year-old white male received POS for treatment of IA from Day 1 to Day 48. He experienced a seizure on Day 49 while hospitalized for bacterial pneumonia. The seizure was accompanied by loss of consciousness, tachycardia, and low oxygen saturation of 81%. Concomitant drugs included mycophenolate mofetil, cyclosporine, fentanyl, bromhexine hydrochloride, cyclosporine, piperacillin/tazobactam, budesonide, vancomycin, valacyclovir, oxycodone, amlodipine, prednisone, omeprazole, lorazepam, foscarnet, and ranitidine. The patient was treated with two anticonvulsant drugs and the episode was assessed as resolved after 40 minutes. A CT scan of the brain was normal. POS was permanently discontinued on Day 49 due to the seizure. Pre-dose POS plasma concentrations were low on treatment with a

Version date: October 12, 2018

concentration 443 ng/mL (144 to 1150 ng/mL) around the time of the seizure. Other risk factors for seizure include hypoxia, and medications such as valacyclovir which has a warning for CNS adverse reactions such as seizure and other medications such as cyclosporine which can cause seizure; however, an association with POS treatment cannot be ruled out.

Patient 2 (drug related): A 66-year-old Asian male received 7 days of POS treatment and experienced a seizure on study Day 9 (1 day post POS treatment). The patient was diagnosed with progression of myelodysplastic syndrome on Day 7. On Day 8, the patient developed sepsis associated with hypotension, loss of consciousness, and was intubated. Posaconazole was withdrawn on Day 8. Pre-dose POS plasma concentration was 726 ng/mL around the time of the seizure (only one result was recorded) during POS treatment.

Concomitant drugs included corydalis yanhusuo (+ morning glory), gliclazide, levothyroxine, insulin, levofloxacin, teneligliptin, rebamipide, famotidine, esomeprazole, prednisolone, remifentanyl, vasopressin, epinephrine, amphotericin B, meropenem, and teicoplanin. On Day 9, patient experienced a seizure during ICU care which was treated with anticonvulsants and assessed as resolved after one hour. The patient recovered from sepsis and was discharged on Day 25. He died from progression of myelodysplastic syndrome on Day 77. Other risk factors for seizure include levofloxacin, meropenem, sepsis, and hypotension; however, an association between seizure and POS treatment cannot be ruled out.

Patient 3 (unrelated to POS): A 35-year-old white female experienced an episode of status epilepticus on Day 13. On Day 8 the patient developed worsening pneumonia, and renal graft infection/UTI, and was intubated. The sputum culture was positive for *Hemophilus influenzae*. The subject remained on mechanical ventilation from Day 8 to Day 12 and was treated with meropenem, vancomycin, and clarithromycin. On Day 13, she experienced a seizure lasting for 13 minutes per the case narrative and 3 mins (probably an error) per the ADAE dataset. Pre-dose POS plasma concentrations ranged from 561 to 4190 ng/mL, with two results reported at Visit 4 (Day 4 to 8): 2080 ng/mL and 4190 ng/mL and there was no result listed for Visit 5 (Day 9 to 15) around the time of the seizure. The plasma level of POS were relatively high (> 3500ng/mL) in the week prior to the onset of seizure.

Concomitant drugs included meropenem, trimethoprim/sulfamethoxazole, potassium chloride, acetaminophen, heparin, amlodipine, vancomycin, piperacillin/tazobactam, clarithromycin, vecuronium bromide, and heparin. Risk factors for seizure include piperacillin/tazobactam and meropenem. The patient was treated with anticonvulsants and recovered. Treatment with POS continued without interruption and there were no further episodes of seizure. The pneumonia improved and she was extubated on Day 20. Between Day 21 and 39, she developed skin rash and CMV infection which resolved prior to her discharge from hospital with no medications on Day 45. As of Day 115, the last known date, the subject had completed the trial.

Clinical Comment: Seizure is not included as an adverse reaction in the Noxafil USPI or Vfend® (VOR) USPI. VORVfend USPI. The three critically ill patients who experienced seizures had other risk factors for seizure; therefore, seizure could not be directly attributed to POS. No labeling for seizure is recommended.

Version date: October 12, 2018

Eye Disorders: TEAEs related to the CNS were mainly visual disorders. In the Eye Disorders system organ class (SOC), there was a lower incidence of TEAEs in POS-treated (6.6%) compared to VOR-treated (12.5%) patients, Table 15-12. These differences were driven by between-group differences in the TEAEs of dyschromatopsia, vision blurred/visual impairment, and hallucination visual, each of which was reported at a lower incidence for POS-treated subjects as compared to VOR-treated patients. The TEAE of dyschromatopsia showed the greatest treatment difference, POS-treated subjects (n=0) and VOR-treated subjects n=6 (2.1%).

Drug-related eye disorders were the most commonly reported adverse events in the trial, occurring in 9.4% of VOR-treated patients and 1.7% of POS-treated patients, Table 10-32. A lower proportion of patients in the POS group experienced disturbances in vision manifested as visual impairment (POS 1.0%, VOR 5.6%), photopsia (POS 0.7%, VOR 2.1%), and dyschromatopsia (POS 0%, VOR 2.1%). These TEAEs were categorized as non-serious except for one SAE of blurred vision which resolved in the VOR group and none of the adverse events led to discontinuation of treatment.

Psychiatric Adverse Events

Psychiatric TEAEs were less common in the POS group than the comparator, POS (35 patients, 12.2%) and VOR (47 patients, 16.4%), Table 15-12. The most reported TEAEs were confusional state (3.5% in the POS group, 5.6% in the VOR group) and hallucination (2.1% and 5.2% in the POS and VOR groups, respectively). The POS group also had a lower incidence of drug related psychiatric TEAEs, (POS 2.1%, VOR 6.6%), Table 10-60.

TEAEs of 'hallucination' (n=21), 'visual hallucination', (n=8) ', and 'hypnagogic hallucination'(n=1) occurred in 30/575 patients (5.2%) in the trial, Table 15-12.

Hallucinations: Fewer POS-treated patients experienced hallucinations. Hallucinations were reported in 6 patients (2.1%) and 15 patients (5.2%) in the POS and VOR groups, respectively. In the POS group, case narratives were reviewed and graphical patient profiles were constructed in JReview for the 6 patients (4 males and 2 females; age range: 38 -80 years) who experienced hallucinations to assess for an association with POS.

Four of the 6 patients were enrolled at one study site in the US. The types of hallucinations were not reported. Two patients the POS group and one patient in the VOR group had SAEs of hallucination, respectively. Hallucinations led to treatment discontinuation in 3 (1%) patients in each treatment group. All patients recovered from hallucinations. Posaconazole plasma concentrations were available for 5 of the 6 patients. The maximum pre-dose plasma

concentrations of POS ranged from 1140 to 3500ng/mL which are within the range for which adequate safety data is available from clinical trials of POS.^{17, 18}

Drug-related hallucinations: There were fewer drug related hallucinations in the POS group, occurring in 4 (1.4%) and 12 (4.2%) in the POS and VOR groups, respectively. Among the four POS-treated patients, hallucinations were described as mild in 3 patients and moderate in one patient. The hallucinations resolved in 1 to 2 days and did not recur after POS was discontinued (positive dechallenge); however, there were no instances of rechallenge.

Study site # (b) (6) USA:

Patient 1 was a 70-year-old male with progressive plasma cell myeloma who experienced hallucinations on Day 9 which was considered study drug-related by the investigator. The case was confounded by the occurrence of fever, a transient ischemic attack, and an acute myocardial infarction on the same study day (Day 9) as the onset of hallucinations. Concomitant medications included pomalidomide and dexamethasone which have CNS adverse effects. The patient died from progression of plasma cell myeloma on Day 48.

Patient 2 was a 38-year-old male patient post HSCT who experienced hallucinations on Day 20 while hospitalized for fever, pneumonia, and sinusitis. He experienced gait disturbance, dizziness, and nausea and vomiting associated with hallucinations. The patient's pneumonia and concomitant use of valacyclovir which has a warning in its labeling for CNS effects including hallucinations, as well as methadone hydrochloride and pregabalin could have contributed to hallucinations in this patient.

Patient 3 was a 57-year-old male, with prolonged neutropenia post HSCT, who experienced mild hallucinations on Day 14 of POS treatment; he recovered on Day 15 and died on Day 21 from engraftment syndrome. His concomitant medications included valacyclovir and ciprofloxacin which have a warnings in their labeling for CNS adverse reactions including hallucinations.

Study site # (b) (6) USA:

Patient 4 was an 80-year-old female with aspergillus sinusitis, left ventricular failure, and hypothyroidism, who experienced mild hallucinations on Day 2 of POS treatment which resolved on Day 3. Posaconazole was discontinued on Day 2. Concomitant medications started around the same time as the hallucinations included doxycycline, albuterol, and trimethoprim /sulfamethoxazole. The patient withdrew from the trial on Day 3. Hallucination is listed as an adverse reaction in the trimethoprim /sulfamethoxazole prescribing information but it is uncommon. No other confounding factors were reported. Hallucinations were possibly related with POS in this patient.

¹⁷ Maertens J, Cornely OA, Ullmann AJ, et al. Phase 1B study of the pharmacokinetics and safety of posaconazole intravenous solution in patients at risk for invasive fungal disease. *Antimicrob Agents Chemother* 2014; 58:3610 – 3617. <http://dx.doi.org/10.1128/AAC.02686-13>.

¹⁸ Duarte RF, Lopez-Jimenez J, Cornely OA, et al. Phase 1B study of new posaconazole tablet for prevention of invasive fungal infections in high risk patients with neutropenia. *Antimicrob Agents Chemother* 2014; 58:5758 –5765. <http://dx.doi.org/10.1128/AAC.03050-14>

Version date: October 12, 2018

Visual hallucinations: Visual hallucinations, a known adverse reaction associated with VOR, occurred in 2 patients (0.7%) in the POS group and 6 patients (2.1%) in the VOR group. Drug related visual hallucinations was reported in one patient in the POS group and 5 patients in the VOR group. The POS-treated patient was a 79-year-old Asian female with aplastic anemia who developed moderate cognitive impairment on Day 15 and visual hallucinations on Day 17 of treatment. POS was discontinued due to hallucinations on Day 18 and the events were categorized as “not recovered” prior to the patient’s death due to septic shock on Day 23. Concomitant medications included spironolactone and prednisolone which can cause mental confusion. Maximum POS pre-dose concentration in this patient was 5010 ng/mL at visit 5 (Day 9 to 15) which is higher than the level (C_{avg} 3500 ng/mL) for which there is adequate safety data from previous POS clinical trials. Visual hallucinations were possibly related with POS in this patient but the assessment was confounded by the patient’s severe illness.

Clinical reviewer’s comment: Fewer patients in the POS group experienced hallucinations or visual hallucinations than in the VOR group. Among the azole antifungal drugs, hallucinations or visual hallucinations are not labeled for POS, itraconazole or fluconazole but hallucinations/visual hallucinations are listed in the voriconazole label. Delirium is listed as an adverse reaction in the isavuconazonium label. Three of the four reported drug related cases of hallucination were confounded by concomitant illnesses and/or the use of medications associated with adverse reactions related to the central nervous system. Hallucinations were not associated with high plasma concentrations of POS. There was not enough clinical evidence to indicate that POS caused hallucinations in these cases.

Visual hallucinations (with a positive dechallenge) were reported in one published case report of a patient who was prescribed labeled doses of POS and had one of the highest blood levels of POS (10.1 µg/mL) reported in published literature.¹⁹ Posaconazole pre-dose plasma levels (5 µg/mL), although high in the patient who experienced visual hallucinations in study P069 trial, were two-fold lower than in the published case report. Visual hallucinations occurring in one critically ill patient on multiple medications, even though POS plasma concentrations were relatively high, is not enough evidence to support the inclusion of this AE in the Noxafil USPI. Posaconazole pre-dose levels in the other patients who experienced hallucinations were less than C_{avg} 3.5µg/mL which is considered relatively safe. It is important to measure POS concentrations in patients who develop visual hallucinations or other hallucinations or CNS-related adverse reactions on POS treatment. ‘Hallucination’ or ‘visual hallucination’ are not recommended, at this time, for inclusion in Section 6, Adverse Reactions of the Noxafil USPI but will be revisited should more cases be reported.

¹⁹ Parkes LO, Cheng MP, Sheppard DC. Visual Hallucinations Associated with High Posaconazole Concentrations in Serum. *Antimicrob Agents Chemother* 2016;60(2):1170-1171.

Version date: October 12, 2018

1.1.1.15. *Dermatologic Adverse Events*

Dermatologic adverse events had prespecified PTs in the Immune System disorders and Skin and Subcutaneous Tissue disorders SOCs. The proportion of patients with dermatologic adverse events was comparable across the two treatment groups for example, skin and subcutaneous tissue disorders occurred in 16% POS-treated patients and 18.5% of VOR-treated patients, Table 15-12.

When preferred terms for all types of rashes (except 'genital rash' and 'injection site rash') were pooled by the reviewer, the incidence of skin rash was similar in the two treatment groups, [POS, 28 patients (9.7%) vs. VOR, 30 patients (10.5%)], Table 15-12 and Table 10-33. Genital rash and injection site rash were excluded because they are not typical sites of drug related rash.

Drug-related Skin and Soft Tissue Disorders

Drug-related skin and soft tissue disorders were relatively uncommon in the POS group, [POS, 4 patients (1.4%) vs. VOR, 10 patients (3.5%)], Table 10-60. The frequency of drug-related skin rash was similar between the two groups, [POS, 3 patients (1.0%) and VOR, 2 patients (0.7%)].

An SAE of generalized exfoliative dermatitis led to the discontinuation of POS in one patient. The patient was a 76-year old white female (acute myeloid leukemia, breast cancer) with prolonged neutropenia and pulmonary aspergillosis who developed generalized exfoliative dermatitis over 90% of her body with pruritus on Day 7 of POS treatment. The patient was taking multiple concomitant medications among which amiodarone could be a suspect drug as it is associated with dermatologic adverse reactions including exfoliative dermatitis; however, the case narrative is not clear if amiodarone was continued or discontinued. Exfoliative dermatitis was considered related to POS by the investigator; therefore, study treatment was unblinded and POS was discontinued on Day 8. The patient was treated with IV antihistamine, anticholinergic therapy, and methylprednisolone, and the dermatitis gradually improved and had resolved by Day 17. The patient was alive as of Day 239 per the case narrative. A second case of exfoliative dermatitis in the POS group was related to contact dermatitis and unrelated to POS. There were no reports of generalized exfoliative dermatitis in the VOR group, although skin exfoliation was reported in 2 patients.

Clinical reviewer's comment: Generalized exfoliative dermatitis or erythroderma is a serious but uncommon skin disorder usually associated with pre-existing dermatosis, a drug-induced adverse reaction, malignancy, or an idiopathic etiology.^{20,21} Cutaneous T-cell lymphoma is a well-recognized association and in some cases acute and chronic leukemias have been associated with exfoliative dermatitis. Antihypertensive drugs, antiepileptic drugs, antibacterial, and some topical drugs have been associated with this dermatologic condition but it can occur with any drug. In this case report, the generalized exfoliative dermatitis was temporally associated with POS treatment

²⁰ Karakayli G, Beckham G, Orengo I, Rosen T. Exfoliative dermatitis. Am Fam Physician. 1999;59(3):625-30.

²¹ Sehgal VN, Srivastava G, Sardana K. Erythroderma/exfoliative dermatitis: a synopsis. Int J Dermatol. 2004 Jan;43(1):39-47. doi: 10.1111/j.1365-4632.2004.01975.x.

in one patient, it led to the discontinuation of POS, and there was a positive dechallenge. Exfoliative dermatitis is not recommended, at this time, for inclusion in the Noxafil USPI because of a confounder of another suspect drug but will be revisited should more cases be reported.

1.1.1.16. Adrenal steroidogenesis – Adverse Events

Adverse events of adrenal insufficiency, hypotension, and orthostatic hypotension were reported in the adrenal steroidogenesis category, i.e. prespecified preferred terms in the Endocrine disorders and Vascular disorders system organ class.

The incidence of hypotension was comparable in the two treatment groups, POS 6.9% vs. VOR 6.6%, Table 10-32. Two cases of orthostatic hypotension occurred in the POS group and one in the voriconazole group; however, none of events were related to the study drugs, and all patients recovered. Two cases of orthostatic hypotension occurred in the POS group and one in the voriconazole group; however, none of events were related to the study drugs, and the patients recovered.

Evaluation of Adrenal Insufficiency

Two cases of adrenal insufficiency, one patient (0.3%) in the POS group and one patient (0.3%) in the VOR group, were reported in the trial.

Patient 1 (POS group): A 63-year-old female patient with acute myelogenous leukemia and invasive aspergillosis was diagnosed with adrenal insufficiency on Day 29 of POS treatment. She was found to have a low serum cortisol level of 11 nmol/L (range 242 - 618 mmol/L which was treated with glucocorticoids; however, a cortisol level was still low at 149.51 mmol/L on Day 41. No hypotension or hypoglycemia were reported to suggest adrenal crisis. The patient had a transient episode of severe hypertension on Day 45 which resolved within one day and the intervention for this AE was unknown. POS was permanently discontinued on Day 49 due to adrenal insufficiency and vomiting. In addition to low cortisol, neutropenia and hypokalemia were present throughout the POS treatment period. As of Day 115, the last recorded study day, the subject had completed follow-up and the TEAE of adrenal insufficiency was ongoing. An association with POS therapy cannot be ruled out as the onset of adrenal insufficiency was contemporaneous with POS treatment.

Patient 2 (VOR group): A 68-year-old male with leukemia, neutropenia, and invasive aspergillosis was diagnosed with hypoxemia, septic shock on Day 15 of VOR treatment and was diagnosed on adrenal insufficiency on the same day. Treatment included amikacin, epinephrine, and hydrocortisone. VOR was withdrawn in response to the event of septic shock with final dose of study medication given on Day 17. On Day 17, the patient deteriorated (hypoxemia, respiratory failure, metabolic acidosis) and died on the same day. The autopsy report noted signs of shock in the liver and kidneys. Adrenal insufficiency can be attributed to septic shock in this case; however, one cannot rule out an association with VOR as therapy was contemporaneous with onset of adrenal insufficiency. Adrenal cortex insufficiency is listed as an adverse reaction in the VOR USPI.

Version date: October 12, 2018

Clinical reviewer's comment: The etiology of adrenal insufficiency in the POS-treated patient is challenging due to missing clinical information, for example, there was no information on possible etiologies such as recent withdrawal of steroid treatment and no result for an ACTH stimulation test. Subnormal corticosteroid production during critical illness such as leukemia and invasive aspergillosis in this patient, in the absence of structural defects in the hypothalamic-pituitary-adrenal axis or "functional adrenal insufficiency", may have been an etiologic factor. One cannot rule out an association with POS because onset of adrenal insufficiency was contemporaneous with POS treatment.

Adrenal insufficiency is listed as a less common adverse reaction in the current Noxafil USPI, and no labeling update is recommended.

Evaluation for Pseudoaldosteronism

Pseudoaldosteronism (also known as pseudohyperaldosteronism) is associated with an aldosterone-independent increase in mineralocorticoid activity which leads to the development of new or worsening hypertension and hypokalemia. Pseudoaldosteronism presents with hypertension, hypokalemia, metabolic alkalosis, and low levels of plasma renin activity. It is a labeled postmarket adverse reaction associated with long term use of labeled doses of POS with suprathreshold POS blood levels.

Current evidence suggest that the underlying mechanism for hypokalemia is may be due to inhibition of the 11 β -hydroxylase enzyme.^{22,23,24} In the literature reports, blood pressure and serum potassium normalized after POS was discontinued or the dose was reduced, when this was reported.

In study P069, patients were evaluated for presence of concurrent hypertension, hypokalemia, and/or metabolic acidosis. No patient had a combination of hypertension, hypokalemia, and metabolic acidosis. Twenty-one patients (3.7%) had TEAEs of hypertension and hypokalemia; 12 patients (4.2%) in the POS group and 9 patients (3.1%) in VOR group. Among the 12 patients in the POS group, 7 patients had a history of hypertension. Hypertension was considered by the investigator to be drug-related in 1 patient and hypokalemia was considered not to be drug related in any of the cases. Cortisol, renin, and aldosterone levels were not reported in the laboratory dataset which limited further evaluation of the patients with hypertension and hypokalemia for evidence of pseudoaldosteronism.

The patient with drug-related hypertension was a 63-year-old Asian female with a history of

²² Thompson GR III, *et al.* In Vivo 11 β -Hydroxysteroid Dehydrogenase Inhibition in Posaconazole-Induced Hypertension and Hypokalemia. *Antimicrob Agents Chemother.* 2017 Jul 25;61(8).

²³ Boughton C, *et al.* Mineralocorticoid hypertension and hypokalemia induced by posaconazole. *Endocrinol Diabetes Metab Case Rep.* 2018 Feb 9.

²⁴ Beck KR, Bachler M, Vuorinen A, *et al.* Inhibition of 11 β -hydroxysteroid dehydrogenase 2 by the fungicides itraconazole and posaconazole. *Biochem Pharmacol* 2017; 93-103.

Version date: October 12, 2018

hypertension who developed an episode of worsening hypertension (Day 45 to 46) associated with POS treatment and had concurrent severe hypokalemia (Day 17 to 50). This patient had other risk factors for hypertension and hypokalemia such as concomitant IV and oral steroids. The dose of POS was not changed and the patient recovered (treatment intervention not specified).

Clinical reviewer's comment: The DAI previously requested that the Applicant conduct periodic safety monitoring to identify possible cases of pseudoaldosteronism by collecting cases of concurrent hypertension and hypokalemia or mineralocorticoid excess identified in the company safety database. In the most recent periodic safety update, of the 24 cases identified by the Applicant, 20 were from one publication²⁵ and the remaining 4 were from literature reports (1 case in each). Twenty-three events identified in this reporting period were reported as non-serious, and the majority were resolved or resolving at the time of the report. The diagnosis and management of pseudoaldosteronism secondary to POS and other azoles can be based on clinical monitoring of serum electrolytes and blood pressure (BP) and correction of BP and potassium levels before and during the treatment, as outlined in the warnings section of the Noxafil USPI.

1.1.1.17. Hypersensitivity

In Immune System Disorders, hypersensitivity reactions were reported in 8 patients (19 to 66 years of age), 3 patients (1.0%) in the POS group and 5 patients (1.7%) in the VOR group. Among these 8 patients, TEAEs of 'drug hypersensitivity' occurred in 2 patients (0.7%) in each treatment group. TEAE of 'hypersensitivity' (verbatim term: 'allergic reaction') occurred in 4 patients, [POS, 1 patient (0.3%) vs VOR, 3 patients (1.0%)]. There were no reports of anaphylaxis. All TEAEs (hypersensitivity or drug hypersensitivity) were described as mild or moderate in severity and all patients recovered and survived.

Among the 4 'hypersensitivity cases', one 47 -year -old male patient in the POS group had an allergic reaction (etiology not specified) which was considered unrelated to POS and the patient remained on POS treatment. The other three cases occurred in the VOR group and one patient discontinued VOR. Overall, there were no hypersensitivity reactions attributed to POS treatment.

10.3.6. Safety Analyses by Demographic Subgroups

1.1.1.18. TEAEs in patients ≥65 years of age

A total of 160 patients ≥65 years of age (POS 85 patients, VOR 75 patients) were enrolled in the trial. A similar proportion of elderly patients in the POS group experienced TEAEs as compared to the VOR group, approximately 98% in both treatment groups, Table 10-61.

Hypokalemia, pyrexia, nausea, increased transaminases, and diarrhea were the most common TEAEs (>20% occurrence) within the POS group. Pyrexia, pneumonia, and hypokalemia were common (>20% occurrence) within the VOR group.

²⁵ Davis MR, Nguyen MH, Gintjee TJ, et al. Management of posaconazole-induced pseudohyperaldosteronism. J Antimicrob Chemother 2020 Dec 1;75(12):3688-3693. doi: 10.1093/jac/dkaa366.

Version date: October 12, 2018

When the TEAEs were compared across the two treatment groups, hypokalemia, nausea, and peripheral edema occurred more frequently (at a $\geq 10\%$ difference) in the POS group versus the VOR group. Increased transaminases were also numerically more common in the POS group. An analysis of TEAEs by age category did not reveal any major differences between types of TEAEs that occurred in patients ≥ 65 years of age and younger patients, 13 to < 65 years of age.

Table 10-61 Study P069: TEAEs in Patients ≥ 65 years of Age by Treatment Group

	Posaconazole N=85 (100%), n/N(%)	Voriconazole N=75 (100%) n/N(%)	Total (N=160, 100%) n/N(%)
Patients with ≥ 1 TEAE	83 (97.6)	74 (98.7)	157 (98.1)
Hypokalemia	26 (30.6)	15 (20.0)	41 (25.6)
Pyrexia	24 (28.2)	19 (25.3)	43 (26.9)
Nausea	23 (27.1)	13 (17.3)	36 (22.5)
Transaminases increased	18 (21.2)	12 (16.0)	30 (18.8)
Diarrhea	17 (20.0)	14 (18.7)	31 (19.4)
Febrile neutropenia	16 (18.8)	14 (18.7)	30 (18.8)
Edema peripheral	16 (18.8)	4 (5.3)	20 (12.5)
Pneumonia	15 (17.6)	15 (20.0)	30 (18.8)
Constipation	13 (15.3)	8 (10.7)	21 (13.1)
Vomiting	13 (15.3)	6 (8.0)	19 (11.9)
Decreased appetite	12 (14.1)	6 (8.0)	18 (11.2)
Dyspnea	11 (12.9)	5 (6.7)	16 (10.0)
Hypomagnesemia	10 (11.8)	4 (5.3)	14 (8.8)
Abdominal pain	9 (10.6)	9 (12.0)	18 (11.2)
Fatigue	9 (10.6)	2 (2.7)	11 (6.9)
Septic shock	9 (10.6)	7 (9.3)	16 (10.0)
Anemia	7 (8.2)	8 (10.7)	15 (9.4)
Bilirubin increased	5 (5.9)	8 (10.7)	13 (8.1)
Blood alkaline phosphatase increased	4 (4.7)	8 (10.7)	12 (7.5)
Thrombocytopenia	4 (4.7)	8 (10.7)	12 (7.5)

Source: OCS Analysis Studio, Custom Table Tool.

Columns - Dataset: Demographics; Filter: TRTFL = 'Y', AGEGR9 = 'From 65 to 84 years' or '85 years and over'.

Table Section 1 - Dataset: Adverse Events; Filter: TRTEMFL = 'Y'; Percent Threshold: $\geq 10\%$.

Clinical reviewer's comment: In the registrational clinical trials (prophylaxis of IFI and treatment of esophageal candidiasis), 286 patients ≥ 65 years of age and 1164 patients < 65 years of age received Noxafil IV or oral formulations. No overall differences in the safety profile or in the pharmacokinetics of Noxafil were observed between the patients ≥ 65 years of age and younger patients in the clinical trials of Noxafil solution for IV injection, delayed-release tablet, and the approved immediate-release oral suspension formulation. No dosage adjustment is recommended for any FDA-approved formulation of Noxafil in patients ≥ 65 years of age.

1.1.1.19. TEAEs analyzed by Sex

Table 10-62 summarizes TEAEs by sex. In the POS treatment group, nausea, vomiting, abdominal pain were numerically more common in female patients than in male patients. Increased

Version date: October 12, 2018

transaminases were marginally more common in male patients in the POS group. For all the TEAEs listed, there was a < 5% difference for each TEAE between male and female patients in the POS group.

Table 10-62 Study P069: TEAEs in Male and Female Patients by Treatment Group

TEAE	Posaconazole		Voriconazole		Total	
	F (N=116)	M (N=172)	F (N=115)	M (N=172)	F (N=231)	M (N=344)
	N (%)	N (%)	N (%)	N (%)	N (%)	N (%)
Pyrexia	37 (31.9)	44 (25.6)	29 (25.2)	43 (25.0)	66 (28.6)	87 (25.3)
Hypokalemia	33 (28.4)	49 (28.5)	22 (19.1)	27 (15.7)	55 (23.8)	76 (22.1)
Nausea	29 (25.0)	36 (20.9)	22 (19.1)	29 (16.9)	51 (22.1)	65 (18.9)
Diarrhea	21 (18.1)	31 (18.0)	23 (20.0)	29 (16.9)	44 (19.0)	60 (17.4)
Transaminases increased	19 (16.4)	34 (19.8)	20 (17.4)	30 (17.4)	39 (16.9)	64 (18.6)
Pneumonia	22 (19.0)	27 (15.7)	16 (13.9)	27 (15.7)	38 (16.5)	54 (15.7)
Vomiting	24 (20.7)	28 (16.3)	20 (17.4)	19 (11.0)	44 (19.0)	47 (13.7)
Febrile neutropenia	14 (12.1)	28 (16.3)	15 (13.0)	23 (13.4)	29 (12.6)	51 (14.8)
Abdominal pain	18 (15.5)	19 (11.0)	20 (17.4)	16 (9.3)	38 (16.5)	35 (10.2)
Headache	9 (7.8)	26 (15.1)	12 (10.4)	13 (7.6)	21 (9.1)	39 (11.3)
Bilirubin increased	11 (9.5)	21 (12.2)	10 (8.7)	16 (9.3)	21 (9.1)	37 (10.8)
Rash	11 (9.5)	17 (9.9)	12 (10.4)	18 (10.5)	23 (10.0)	35 (10.2)
Edema peripheral	15 (12.9)	17 (9.9)	12 (10.4)	12 (7.0)	27 (11.7)	29 (8.4)
Anemia	9 (7.8)	17 (9.9)	13 (11.3)	16 (9.3)	22 (9.5)	33 (9.6)
Constipation	9 (7.8)	23 (13.4)	10 (8.7)	13 (7.6)	19 (8.2)	36 (10.5)
Cough	14 (12.1)	16 (9.3)	14 (12.2)	10 (5.8)	28 (12.1)	26 (7.6)
Dyspnea	9 (7.8)	20 (11.6)	11 (9.6)	14 (8.1)	20 (8.7)	34 (9.9)
Hypertension	9 (7.8)	19 (11.0)	10 (8.7)	13 (7.6)	19 (8.2)	32 (9.3)
Blood alkaline phosphatase increased	8 (6.9)	13 (7.6)	10 (8.7)	19 (11.0)	18 (7.8)	32 (9.3)
Epistaxis	12 (10.3)	20 (11.6)	7 (6.1)	10 (5.8)	19 (8.2)	30 (8.7)
Hypomagnesemia	8 (6.9)	21 (12.2)	7 (6.1)	11 (6.4)	15 (6.5)	32 (9.3)
Decreased appetite	12 (10.3)	13 (7.6)	3 (2.6)	11 (6.4)	15 (6.5)	24 (7.0)
Total	113 (97.4)	168 (97.7)	112 (97.4)	168 (97.7)	225 (97.4)	336 (97.7)

Source: OCS Analysis Studio, Custom Table Tool.

Columns - Dataset: Demographics; Filter: TRTFL = 'Y'.

Table Section 1 - Dataset: Adverse Events; Filter: TRTEMFL = 'Y'; Percent Threshold: >= 10%.

Table Section 2 - Dataset: Adverse Events; Filter: TRTEMFL = 'Y'.

1.1.1.20. TEAEs analyzed by Race

Most patients in the trial were White (67.3%) followed by Asian (21.5%) and all other races (Black, Multiracial, American Indian or Alaskan native) combined (11%), Table 10-63. There were no major differences between the POS and VOR treatment groups for disorders categorized by SOC; however, no definitive conclusions can be drawn about drug adverse effects based on race because of the low numbers of patients in race categories other than White. Within the treatment groups, some differences between White and Asian patients are noteworthy. In the POS group, Asian patients had higher incidence of TEAEs in the Investigations SOC as compared to White patients, 62.9% vs. 39.7%, respectively. Increased aminotransferases were twice as common in

Version date: October 12, 2018

the Asian population as compared to the White population, (30.6% versus 15.5%, respectively) and contributed to the observed difference. In the POS group, White patients experienced more psychiatric adverse events than Asian patients, 25% vs. 8%, respectively. In the VOR group, a similar trend in incidence of TEAEs was observed in the Investigations SOC and Psychiatric SOC among White and Asian patients.

Table 10-63 Study P069: TEAEs by Race and Treatment Group

	Posaconazole					Voriconazole				
	American Indian or Alaska Native (N=4)	Asian (N=62)	Black (N=3)	Multi-Racial (N=25)	White (N=194)	American Indian or Alaska Native (N=6)	Asian (N=60)	Black (N=4)	Multi-Racial (N=25)	White (N=192)
System Organ Class										
Infections and infestations	3 (75.0)	45 (72.6)	3 (100.0)	19 (76.0)	121 (62.4)	6 (100.0)	33 (55.0)	2 (50.0)	16 (64.0)	128 (66.7)
Gastrointestinal disorders	1 (25.0)	37 (59.7)	3 (100.0)	14 (56.0)	107 (55.2)	3 (50.0)	34 (56.7)	1 (25.0)	15 (60.0)	110 (57.3)
General disorders and administration site conditions	2 (50.0)	34 (54.8)	1 (33.3)	4 (16.0)	114 (58.8)	1 (16.7)	28 (46.7)	1 (25.0)	10 (40.0)	97 (50.5)
Respiratory, thoracic and mediastinal disorders	2 (50.0)	31 (50.0)	0	11 (44.0)	97 (50.0)	1 (16.7)	19 (31.7)	2 (50.0)	7 (28.0)	79 (41.1)
Metabolism and nutrition disorders	3 (75.0)	38 (61.3)	0	13 (52.0)	88 (45.4)	2 (33.3)	29 (48.3)	1 (25.0)	7 (28.0)	70 (36.5)
Investigations	3 (75.0)	39 (62.9)	0	6 (24.0)	77 (39.7)	2 (33.3)	30 (50.0)	2 (50.0)	5 (20.0)	77 (40.1)
Nervous system disorders	2 (50.0)	15 (24.2)	0	6 (24.0)	72 (37.1)	0	11 (18.3)	0	4 (16.0)	63 (32.8)
Blood and lymphatic system disorders	2 (50.0)	22 (35.5)	0	11 (44.0)	61 (31.4)	2 (33.3)	20 (33.3)	0	7 (28.0)	57 (29.7)
Skin and subcutaneous tissue disorders	1 (25.0)	18 (29.0)	0	6 (24.0)	58 (29.9)	0	15 (25.0)	0	4 (16.0)	60 (31.2)
Psychiatric disorders	0	5 (8.1)	0	5 (20.0)	48 (24.7)	2 (33.3)	9 (15.0)	2 (50.0)	2 (8.0)	55 (28.6)
Musculoskeletal and connective tissue disorders	1 (25.0)	11 (17.7)	0	5 (20.0)	51 (26.3)	0	9 (15.0)	1 (25.0)	3 (12.0)	44 (22.9)
Vascular disorders	1 (25.0)	7 (11.3)	0	5 (20.0)	46 (23.7)	0	12 (20.0)	0	1 (4.0)	47 (24.5)
Renal and urinary disorders	0	18 (29.0)	0	9 (36.0)	44 (22.7)	0	10 (16.7)	2 (50.0)	2 (8.0)	33 (17.2)
Cardiac disorders	0	13 (21.0)	0	2 (8.0)	32 (16.5)	3 (50.0)	7 (11.7)	2 (50.0)	1 (4.0)	39 (20.3)
Injury, poisoning and procedural complications	0	0	0	7 (28.0)	33 (17.0)	0	6 (10.0)	1 (25.0)	4 (16.0)	29 (15.1)
Eye disorders	0	8 (12.9)	1 (33.3)	3 (12.0)	23 (11.9)	1 (16.7)	7 (11.7)	2 (50.0)	1 (4.0)	37 (19.3)
Neoplasms benign, malignant and unspecified (incl cysts and polyps)	2 (50.0)	4 (6.5)	0	2 (8.0)	24 (12.4)	2 (33.3)	4 (6.7)	0	1 (4.0)	24 (12.5)

Source: OCS Analysis Studio, Custom Table Tool.
 Columns - Dataset: Demographics; Filter: TRTFL = 'Y'.
 Table Section 1 - Dataset: Adverse Events; Filter: TRTEMFL = 'Y'; Percent Threshold: >= 20%.

Clinical reviewer's comment: As outlined in the Applicant's 2019 Periodic Adverse Experience Reports (PAERs), there were two studies conducted in Asia which could provide additional safety information for POS in Asian patients with IA. Study PN101 is a phase 3, randomized, comparative, Version date: October 12, 2018

open-label study to assess the safety and efficacy of POS compared with VOR in Japanese patients with deep-seated fungal infection (invasive aspergillosis, chronic pulmonary aspergillosis, fusariosis or zygomycosis). In total 94 subjects enrolled in this study. The applicant stated that CSR is complete for the study and no new safety findings were reported in this study as of the reporting period. Study PN120 was a Phase 1b, open-label, single arm, multi-center study of the pharmacokinetics and safety of POS IV in Chinese subjects at high risk for invasive fungal infections. Results from study PN120 demonstrated that the AUC was found to be 25% higher in Chinese patients relative to patients from other races/ethnicities. The clinical pharmacology reviewers concluded that this higher exposure is not expected to be clinically relevant given the expected variability in POS exposure. Chinese ethnicity was identified as a significant covariate in the population pharmacokinetic analysis for POS – see pharmacometrics review (section 15.4.5) for additional information.

1.1.1.21. TEAEs analyzed by Region

There were no major differences in the incidence of TEAEs by region in the POS and the VOR treatment groups with more than 95% of patients in all regions experiencing at least one TEAE in the POS and VOR treatment groups, Table 10-64.

Table 10-64 Study P069: TEAEs by Region/Continent and Treatment Group

	Posaconazole				Voriconazole				Total			
	Asia Pacific (N=61)	Europe (N=149)	North America (N=43)	South America (N=35)	Asia Pacific (N=60)	Europe (N=147)	North America (N=39)	South America (N=41)	Asia Pacific (N=121)	Europe (N=296)	North America (N=82)	South America (N=76)
No. of patients with ≥ one TEAE	61 (100)	145 (97.3)	41 (95.3)	34 (97.1)	59 (98.3)	144 (98.0)	38 (97.4)	39 (95.1)	120 (99.2)	289 (97.6)	79 (96.3)	73 (96.1)

Source: OCS Analysis Studio, Custom Table Tool.

Columns - Dataset: Demographics; Filter: TRTFL = 'Y'.

Table Section 1 - Dataset: Adverse Events; Filter: TRTEMFL = 'Y'; Percent Threshold: >= 10%.

10.3.7. Specific Safety Studies/Clinical Trials

Not applicable

1.1.1.22. Additional Safety Explorations

Human Carcinogenicity or Tumor Development

Not applicable.

Human Reproduction and Pregnancy

Not applicable.

Pediatrics and Assessment of Effects on Growth

Not applicable.

Version date: October 12, 2018

NDA Multi-disciplinary Review and Evaluation, sNDA 205596, 205053, 214770
NOXAFIL® (posaconazole) injection, delayed release tablet, PowderMix
For prophylaxis of invasive fungal infections in pediatric patients 2 years of age and older
For treatment of invasive aspergillosis in adults and pediatric patients 13 years and older

Overdose, Drug Abuse Potential, Withdrawal, and Rebound

Not applicable.

10.3.8. Safety in the Postmarket Setting

1.1.1.23. Safety Concerns Identified Through Postmarket Experience

Since its approval in the US in 2006, safety data to support safety labeling updates to the Noxafil USPI have come from clinical trials, periodic safety updates (PSUR) from the Applicant, spontaneous reporting through FAERS, and published literature. POS is marketed in approximately 70 countries. The total cumulative patient exposure for POS through Oct 25, 2019 was approximately (b) (4) patient-years of treatment, i.e., (b) (4) for the oral suspension; (b) (4) for delayed-release tablets; and (b) (4) for the IV formulation as outlined in the 2019 PSUR. The Applicant submitted the results of a search of their global safety database for POS. The Applicant's search revealed that as of October 25, 2019, there were 6,240 case reports containing 13,091 events (7,725 nonserious, 5,366 serious) from spontaneous and noninterventive postmarket study reports in the safety database. The Applicant's cumulative analysis of the postmarket AEs did not reveal new safety signals for POS.

Clinical reviewer's comment: The safety information presented in the Applicant's post market analysis is consistent with recent periodic safety update reports (PSURs) for POS in 2019 and 2020 and with the adverse reactions listed in the Noxafil USPI.

1.1.1.24. Expectations on Safety in the Postmarket Setting

In the post market setting, monitoring of the safety of POS formulations continues through the Applicant's global safety database. Yearly safety updates are submitted to the Agency in Periodic Adverse Experience Reports. Safety signals may also be identified through spontaneous reporting in FDA Adverse Event Reporting System (FAERS) and from case reports in published literature.

10.3.9. Integrated Assessment of Safety

Study 069 augments the available clinical trial safety data for posaconazole IV injection and delayed-release tablet over an extended treatment duration (median of 67 days) in critically ill, immunocompromised patients. The reviewer's assessment of the safety data for POS IV and delayed-release tablets for treatment of IA found that:

- The incidence of TEAEs was identical in the POS and VOR treatment groups.
- Fewer patients in the POS group had treatment-related adverse events and fewer patients discontinued POS due to an adverse event than in the VOR group.
- A lower proportion of patients treated with POS experienced TEAEs related to skin, eye, and psychiatric disorders as compared to VOR; differences were driven by dyschromatopsia, abnormalities of vision, and hallucinations with each being more common in the VOR group.

Version date: October 12, 2018

- A higher proportion of patients treated with POS experienced hepatobiliary disorders and metabolism and nutrition disorders as compared to VOR; differences were driven by elevated aminotransferases/total bilirubin and hypokalemia, respectively.
- There was no evidence of an increase in potential Hy's Law cases in the POS-treated patients compared to the VOR-treated patients.
- Adverse events in patients ≥ 65 years of age were similar to adverse events in younger patients, 13 to < 65 years of age.
- POS IV and delayed-release tablets was generally well tolerated and appeared to be better tolerated than VOR.
- POS had a generally similar safety profile to VOR and no new significant safety signals were identified for POS in the P069 trial.
- The safety profile of POS in Study P069 is consistent with the safety data in current product labeling of Noxafil IV and the delayed-release tablet and recently submitted periodic safety update reports for POS.
- Monitoring of hepatic function, serum electrolytes, and vigilance for potential drug-drug interactions throughout POS therapy are important for patient safety as stated in the Noxafil USPI.

11 Pediatrics

The pediatric development program for Noxafil injection and delayed release tablet formulations (Pediatric study P097) fulfilled the following PREA PMR for the indication of prophylaxis of IFI:

- **2090-1/2132-1** Conduct a trial in patients, ages 2 to < 18 years, to evaluate the pharmacokinetics (PK), safety, and tolerability of two new formulations of posaconazole (IV solution and/or new age appropriate oral formulation) in immunocompromised pediatric patients with known or expected neutropenia

The Applicant developed a new age appropriate oral formulation Noxafil PowderMix (for delayed release oral suspension) and identified an appropriate dose regimens for prophylaxis of IFIs in pediatric patient 2 years of age and older for both IV Injection and PowderMix oral formulations that achieve posaconazole exposures found to be efficacious in adults for the same indication.

- **2090-2/2132-2** Conduct a comparative, double-blind, randomized, multi-center trial, in patients ages 2 to < 18 years, to evaluate the safety, efficacy, and tolerability of posaconazole for the prophylaxis of invasive fungal infections (IFI) in pediatric patients with known or expected neutropenia. The Agency added that PMRs 2090-2/2132-2 were required if the results of the pediatric study did not demonstrate similar exposures to adults

This PMR study was determined to be not necessary and the Applicant will be released from this PMR as an appropriate IV and oral posaconazole dose regimen for pediatric patients 2 years of age and older has been determined based on the results of P097.

The pediatric assessment has been presented at the Pediatric Research Committee (PeRC) meeting on May 19, 2021, and PeRC agreed with the Division.

Noxafil has orphan designation for the indication of treatment of invasive aspergillosis; therefore, PREA does not apply, and the Applicant is not required to evaluate Noxafil for this indication in pediatric patients. (b) (4), (b) (5)

This review will specifically assess the available safety data for the POS 6mg/kg/day dose which is proposed for marketing. The primary source of patient-level safety data was adverse events reported during POS therapy and post therapy from Study P097. Additional supportive safety data sources include postmarket safety data from the applicant's global safety database for POS, and published literature.

Deaths, treatment emergent adverse events (TEAEs), serious adverse events (SAEs), and adverse events (AEs) of special interest associated with triazole drugs are evaluated and compared across age and dose cohorts for posaconazole treatment groups. Those TEAEs and SAEs that led to drug discontinuation, withdrawal, and/or death were evaluated in more depth. Adverse events in Study P097 were compared to adverse events reported in patients > 13 years of age in Study P069 as well as to the known safety profile of triazole antifungals.

Study MK-5592-097 is a pharmacokinetic (PK), safety, and tolerability study of intravenous (IV) sulfobutylether-beta-cyclodextrin-containing (SBE β CD) formulation which is currently approved in adults (hereafter referred to as "POS IV") and (2) oral granules for suspension prepared as a single-use powder for reconstitution (which has the same components adult-approved POS oral tablet; hereafter referred to as "POS PFS") for prophylaxis of invasive fungal infections in immunocompromised pediatric patients with neutropenia or expected neutropenia. This was nonrandomized and open-label study evaluating three dose cohorts of posaconazole (3.5mg/kg, 4.5mg/kg, and 6mg/kg) in 2 pediatric age groups (2 to <7years old and 7 to 17 years old) conducted at 24 centers in multiple countries.

IV POS was administered BID on day 1 as a loading dose followed by once daily on days 2-10 (minimum 10 days) and then switched to POS PFS for a minimum of 10 days if still neutropenic. If subjects were unable to tolerate/refused oral medication they were given the option of remaining on POS IV beyond 10 days with permittance to oral transition any time through day 18 and/or completion of study. POS PFS may have been continued beyond 10 days if a subject remained neutropenic. A maximum of 300mg per dose was administered and the maximum duration of POS IV +/- POS PFS was 28 days. Safety follow up extended to 14 days after EOT, and survival assessment was performed between Days 90-110.

Source: Figure 9-1 Study Diagram of CSR

Patients were excluded from the study if they had a proven or probable IFI (per 2008 EORTC/MSG consensus criteria) had received POS within ten days or any prohibited drugs (whether prior to or expected during study), had abnormal screening labs (AST >5x ULN, ALT >5xULN, total bilirubin (Tbili) >2.5x ULN, AST or ALT >3xULN AND serum Tbili 2x ULN, CrCl calculated <30mL/min), had prolonged screening QTc (using Fridericia or Bazett's correction and defined as >450msec for males or >470msec for females or >500msec for anyone), were pregnant, breastfeeding, or had plans to become pregnant during study, had a history of azole-related anaphylaxis, or had an additional clinical condition that in the opinion of the investigator would interfere with the study (i.e. would not receive expected minimum duration of study drug, previous participation, previous phase 1 clinical study participation for an IND (30 days prior or 60 days after randomization), or had known family member involved with study)..

Version date: October 12, 2018

NDA Multi-disciplinary Review and Evaluation, sNDA 205596, 205053, 214770

NOXAFIL® (posaconazole) injection, delayed release tablet, PowderMix

For prophylaxis of invasive fungal infections in pediatric patients 2 years of age and older

For treatment of invasive aspergillosis in adults and pediatric patients 13 years and older

Secondary: Evaluation of safety and tolerability of POS IV and PFS in immunocompromised pediatric patients age 2 to 17 years of age with expected or actual neutropenia by adverse events, lab abnormalities (hematology and chemistry specifically), vital signs, and electrocardiogram (ECG) results as well as POS PFS palatability and acceptability.+

A population PK analysis was done “to characterize POS PK and assess potential covariates” following administration of POS IV and PFS.

All results were descriptive as there was no formal hypothesis to be tested in this study.

Protocol Amendments

Amendment 2 (May 2017) added a third dose cohort (6mg/kg) based on review of the PK data from dose cohorts 1 and 2 (3.5mg/kg and 4.5mg/kg, respectively). Although the 4.5mg/kg dose cohort successfully achieved PK target ~90% subjects having steady state C_{avg} concentration between specified 500ng/mL to 2500ng/mL for both IV and PFS formulations, the overall exposures (as measured by mean C_{avg} concentrations) were noted to be 30-40% lower than corresponding values in adult studies of the delayed-release tablet. The 6mg/kg dose cohort and an increase in the minimum enrollment were thus implemented to better match adult systemic target exposures and to augment the safety database.

The Applicant certified that Study P097 was conducted in compliance with GCP.

The study under review was determined to be low risk as not efficacy assessments were performed; no clinical inspections were recommended. The review of the clinical and clinical pharmacology data submitted did not identify any data quality/integrity issues.

Reviewer’s Comment: *It should be noted, however, that the DMEPA review of the POS PFS Human Factor study indicated multifactorial drug administration issues related to the viscosity of the constituted suspension, notched tip syringe, air bubbles, +/- comprehension of the preparation/administration instructions, which impacted the precision in administering doses greater than 8mL (240mg) (excursions ±12.5%). Therefore, although the study protocol stated a maximum dose of 300mg for the proposed 6mg/kg dose for marketing for both IV and PFS formulations (i.e. for patients greater than or equal to 50kg), it is unclear whether patients weighing greater than 40kg who were given PFS doses ranging from greater than 240mg (8mL) to 300 mg (10mL) were able to receive the full calculated POS PFS dose and if so, how these doses were administered and why there is this seeming discrepancy given the fact that all subjects/caregivers were reportedly using the same supplies/instructions for preparation/administration as proposed for marketing.*

No financial disclosure to report. Refer to section 15.1 for details.

Among the 118 subjects enrolled in the study, 115 subjects received at least one dose of the study drug. Six subjects were withdrawn from the study, 2 because of death, 2 because of a physician decision, 1 because of an adverse event, and 1 because of a protocol deviation, **Error! Reference source not found.** Eighteen of these subjects experienced adverse events leading to study drug
Version date: October 12, 2018

discontinuations, 14 subjects discontinued the study drug due to physician decision, 3 due to withdrawal by a parent/guardian, and 2 were due to protocol deviation.

	Treatment 3.5 mg/kg		Treatment 4.5 mg/kg		Treatment 6 mg/kg		Total	
	2-<7 (N=14)	7-17 (N=21)	2-<7 (N=15)	7-17 (N=16)	2-<7 (N=19)	7-17 (N=30)	2-<7 (N=48)	7-17 (N=67)
DISPOSITION								
ENROLLED	14 (100.0)	21 (100.0)	15 (100.0)	16 (100.0)	19 (100.0)	30 (100.0)	48 (100.0)	67 (100.0)
STUDY WITHDRAWAL	0	1 (4.8)	1 (6.7)	0	1 (5.3)	3 (10.0)	2 (4.2)	4 (6.0)
DEATH	0	0	0	0	1 (5.3)	1 (3.3)	1 (2.1)	1 (1.5)
PHYSICIAN DECISION	0	1 (4.8)	1 (6.7)	0	0	0	1 (2.1)	1 (1.5)
ADVERSE EVENT	0	0	0	0	0	1 (3.3)	0	1 (1.5)
PROTOCOL DEVIATION	0	0	0	0	0	1 (3.3)	0	1 (1.5)
STUDY DRUG	14 (100.0)	20 (95.2)	14 (93.3)	16 (100.0)	18 (94.7)	27 (90.0)	46 (95.8)	63 (94.0)

Source: OCS Analysis Studio, Custom Table Tool.
 Columns - Dataset: Demographics Filter: TRTFL = "Y".
 Disposition by Study Completed/Discontinued - Dataset: Disposition Filter: DSDECOD = 'ADVERSE EVENT' or 'COMPLETED' or 'WITHDRAWAL BY PARENT/GUARDIAN' or 'PHYSICIAN DECISION' or 'PROTOCOL DEVIATION' or 'SCREEN FAILURE' or 'DEATH'.
 Disposition by Event and Subcategory - Dataset: Disposition; Filter: DSCAT = 'DISPOSITION EVENT'.
 Disposition with Subject Identifiers (excluding completed) - Dataset: Disposition; Filter: DSDECOD = 'ADVERSE EVENT' or 'WITHDRAWAL BY PARENT/GUARDIAN' or 'PHYSICIAN DECISION' or 'PROTOCOL DEVIATION' or 'SCREEN FAILURE' or 'DEATH'.
 Disposition - Dataset: Disposition; Filter: DSDECOD = 'ADVERSE EVENT' or 'COMPLETED' or 'WITHDRAWAL BY PARENT/GUARDIAN' or 'PHYSICIAN DECISION' or 'PROTOCOL DEVIATION' or 'SCREEN FAILURE' or 'DEATH'.

Protocol Violations/Deviations

There were 45 subjects (39.1%) with reported, significant protocol deviations, 12 of whom had deviations related to the study drug: 10 affected POS IV dosing and 2 affected POS PFS dosing. Of the 115 subjects started on POS IV, 15 (13%) were not included in PK analyses because they did not meet *patient acceptability criteria* (9 due to PK concentration levels not being obtained, 5 due to dose not being given within 6 hours of scheduled time, and 1 was excluded as an outlier). Of the 63 subjects successfully transitioned to POS PFS, 13 (20.6%) were not included in PK analyses because they did not meet *patient acceptability criteria* (10 due to PK concentrations or samples not being collected and 3 due to incomplete doses being taken). Of the 63 subjects successfully transitioned to POS PFS, 50 were included in the PK analysis with the following breakdown by dose cohort:

- 15/17 (88%) in 3.5mg/kg (5/6 (83%) in age group 1 and 10/11 (90%) in age group 2)
- 16/18 (88%) in 4.5 mg/kg (8/9 (88%) in age group 1 and 8/9 (88%) in age group 2)
- 19/28 (67%) in 6mg/kg (7/14 (50%) in age group 1 and 12/14 (85.7%) from age group 2)

Not all subjects with important study intervention-related deviations were excluded from the PK analysis. Subjects with deviations affecting study intervention were only excluded from PK analyses based on the timing and nature of the deviation and if the subject did not satisfy the prespecified Patient Acceptability Criteria.

Ten subjects in PFS treatment group did not have the 24-hour PK sample making AUC₀₋₂₄ and C_{avg} calculations impossible. Based upon the assumption, however, that steady state PK concentrations are achieved by Day 7, the pre-dose samples were taken to be equivalent to the 24-hour PK sample and applied to support estimation of AUC 0-24 and consequently C_{avg}.

Version date: October 12, 2018

Additionally, the PK profile of one subject was excluded from the primary analysis but included in a sensitivity analysis after demonstrating a prominent rise to C_{max} followed by a rapid decline to C_{min}: an inconsistent pattern to the known PK profile of POS that is relatively flat with minor C_{max} to C_{min} fluctuations and slow elimination.

The PK analysis population included a total of 100 subjects for POS IV and 50 subjects for PFS. A population PK analysis was also conducted separately. No important protocol deviations were classified as GCP compliance issues.

Reviewer's Comment: Only 67% of all subjects who received the proposed dose for marketing, POS PFS 6mg/kg, (as compared to 88% of subjects in both 3.5mg/kg and 4.5mg/kg dose cohorts were included in the PK analyses. Only 50% of subjects in Age Group 1 of the 6mg/kg POS PFS dose cohort (compared to 83% and 88% in Age Group 1 of 3.5mg/kg and 4.5mg/kg dose cohorts, respectively) were included in the PK analyses. The seemingly disproportionate exclusion of subjects from the 6mg/kg dose cohort, particularly in Age Group 1, is of unclear significance given the small sample size, but should be noted.

Demographic and Other Baseline Characteristics

Error! Reference source not found. displays demographic characteristics of patients in the safety analysis set. There were no clinically meaningful differences in demographics/underlying disease characteristics observed between dose cohorts. The majority of subjects were white (83.5%), not Hispanic or Latino (87%) and male (58.3%) with a median age of 8 years old and with the most common underlying premedical qualifying conditions being acute leukemia (44.3%), HSCT (44.3%), and high risk neuroblastoma (13.9%).

Table 11-1 Baseline Characteristics All Subjects as Treated

	Treatment 3.5 mg/kg Age Group1 (2-<7 years) n (%)	Treatment 3.5 mg/kg Age Group2 (7-17 years) n (%)	Treatment 4.5 mg/kg Age Group1 (2-<7 years) n (%)	Treatment 4.5 mg/kg Age Group2 (7-17 years) n (%)	Treatment 6 mg/kg Age Group 1 (2-<7 years) n (%)	Treatment 6 mg/kg Age Group 2 (7-17 years) n (%)	Total n (%)
Subjects in Population [†]	14	21	15	16	20	29	115
Gender							
Male	12 (85.7)	10 (47.6)	7 (46.7)	9 (56.3)	10 (50.0)	19 (65.5)	67 (58.3)
Female	2 (14.3)	11 (52.4)	8 (53.3)	7 (43.8)	10 (50.0)	10 (34.5)	48 (41.7)
Age (Years)							
Mean	3.93	13.86	4.07	12.19	3.85	12.00	8.93
SD	1.44	2.08	1.44	2.48	1.60	3.47	4.95
Median	3.00	14.00	4.00	12.00	3.50	12.00	8.00
Range	2 to 6	10 to 17	2 to 6	7 to 16	2 to 7	7 to 17	2 to 17
Race							

Version date: October 12, 2018

	Treatment 3.5 mg/kg Age Group1 (2-<7 years) n (%)	Treatment 3.5 mg/kg Age Group2 (7-17 years) n (%)	Treatment 4.5 mg/kg Age Group1 (2-<7 years) n (%)	Treatment 4.5 mg/kg Age Group2 (7-17 years) n (%)	Treatment 6 mg/kg Age Group 1 (2-<7 years) n (%)	Treatment 6 mg/kg Age Group 2 (7-17 years) n (%)	Total n (%)
Asian	4 (28.6)	1 (4.8)	2 (13.3)	2 (12.5)	1 (5.0)	1 (3.4)	11 (9.6)
Black Or African American	0 (0.0)	0 (0.0)	0 (0.0)	0 (0.0)	1 (5.0)	2 (6.9)	3 (2.6)
Multiple	0 (0.0)	2 (9.5)	0 (0.0)	2 (12.5)	0 (0.0)	0 (0.0)	4 (3.5)
Native Hawaiian Or Other Pacific Islander	0 (0.0)	0 (0.0)	1 (6.7)	0 (0.0)	0 (0.0)	0 (0.0)	1 (0.9)
White	10 (71.4)	18 (85.7)	12 (80.0)	12 (75.0)	18 (90.0)	26 (89.7)	96 (83.5)
Ethnicity							
Hispanic Or Latino	1 (7.1)	2 (9.5)	2 (13.3)	4 (25.0)	1 (5.0)	2 (6.9)	12 (10.4)
Not Hispanic or Latino	13 (92.9)	19 (90.5)	12 (80.0)	11 (68.8)	18 (90.0)	27 (93.1)	100 (87.0)
Not Reported/Unknown	0 (0.0)	0 (0.0)	1 (6.7)	1 (6.3)	1 (5.0)	0 (0.0)	3 (2.6)
Specific Baseline Disease^{††}							
Acute Leukemia	3 (21.4)	8 (38.1)	4 (26.7)	11 (68.8)	8 (40.0)	17 (58.6)	51 (44.3)
Myelodysplasia	0 (0.0)	0 (0.0)	1 (6.7)	1 (6.3)	0 (0.0)	2 (6.9)	4 (3.5)
Severe Aplastic Anemia	3 (21.4)	3 (14.3)	3 (20.0)	1 (6.3)	2 (10.0)	1 (3.4)	13 (11.3)
Recipients of HSCT	7 (50.0)	13 (61.9)	9 (60.0)	2 (12.5)	7 (35.0)	13 (44.8)	51 (44.3)
High Risk	2 (14.3)	0 (0.0)	5 (33.3)	2 (12.5)	5 (25.0)	2 (6.9)	16 (13.9)
Neuroblastoma							
Advanced stage NHL	0 (0.0)	1 (4.8)	0 (0.0)	1 (6.3)	0 (0.0)	0 (0.0)	2 (1.7)
Hemophagocytic Lymphohistiocytosis	1 (7.1)	0 (0.0)	0 (0.0)	0 (0.0)	0 (0.0)	1 (3.4)	2 (1.7)
Other [‡]	0 (0.0)	1 (4.8)	1 (6.7)	0 (0.0)	0 (0.0)	0 (0.0)	2 (1.7)
Weight (kg)							
Mean	18.61	53.40	17.42	49.02	17.43	46.25	35.80
SD	7.26	14.72	3.69	21.11	5.12	23.16	22.13
Median	15.85	51.50	17.60	44.20	16.40	39.30	28.60
Range	12.8 to 41.7	24.7 to 83.3	12.3 to 24.4	21.3 to 95.8	10.2 to 28.6	18.2 to 101.6	10.2 to 101.6
Height (cm)							
Mean	103.82	160.62	105.81	153.39	104.20	153.22	133.97
SD	11.68	14.36	11.50	15.98	13.86	23.54	30.34
Median	100.00	160.00	109.00	156.00	102.00	150.00	132.00
Range	87 to 122.5	133 to 189.6	81.6 to 119	125 to 182	83 to 130	114 to 195	81.6 to 195
[†] 3 subjects were enrolled but not treated.							
^{††} It is possible for a subject to have more than one condition. Subjects with multiple conditions will be							

Version date: October 12, 2018

	Treatment 3.5 mg/kg Age Group1 (2-<7 years) n (%)	Treatment 3.5 mg/kg Age Group2 (7-17 years) n (%)	Treatment 4.5 mg/kg Age Group1 (2-<7 years) n (%)	Treatment 4.5 mg/kg Age Group2 (7-17 years) n (%)	Treatment 6 mg/kg Age Group 1 (2-<7 years) n (%)	Treatment 6 mg/kg Age Group 2 (7-17 years) n (%)	Total n (%)
--	---	---	---	---	--	--	----------------

counted once in each condition. Subjects who do not have any of these 7 specific diseases reported will be counted in Other category.

‡ Baseline disease for the 2 subjects categorized as Other were alveolar rhabdomyosarcoma, and receipt of an autologous bone marrow transplantation.

H SCT= hematopoietic stem cell transplantation, NHL=non-Hodgkin's lymphoma.

Weight and height are summarized using the last observation prior to the first dose of study drug.

Source: Adapted from the Study report P097

NDA Multi-disciplinary Review and Evaluation, sNDA 205596, 205053, 214770
NOXAFIL® (posaconazole) injection, delayed release tablet, PowderMix
For prophylaxis of invasive fungal infections in pediatric patients 2 years of age and older
For treatment of invasive aspergillosis in adults and pediatric patients 13 years and older

Treatment Compliance, Concomitant Medications, and Rescue Medication Use

No rescue or supportive medications were specified to be used in this trial. Subjects who developed superficial fungal infections (e.g. cutaneous, thrush, *Candida* vaginitis), were permitted to be treated with topical antifungal agents and continued on study drug pending no further systemic involvement or more extensive mucosal involvement. There was also no diet or activity restrictions; however, information was collected during POS PFS treatment including timing of the study drug dose, type of meal consumed (if any), and timing of the meal relative to the study medication.

***Reviewer's Comment:** Interestingly neither of the adult studies of POS for IFI prophylaxis prohibited the use of systemic antifungals one of which had a significantly larger proportion of patients placed on systemic antifungals compared to the other that might have had an impact on the exposure response for efficacy. In this study, it should also be noted that systemic antifungal therapy used for treatment of IFI required a minimum 30-day washout period (with deviations requiring approval by the Sponsor); however, other systemic antifungal therapy (oral, IV, or nasal/inhaled) used for prophylaxis of IFI did not require any specified washout period. Depending on the dose/timing of each antifungal (compared to treatment dose/timing) and a specific antifungal used, the number of breakthrough fungal infections reported could potentially be lower than that may have been reported otherwise.*

Safety Review Approach:

See Pediatric subsections titled Sources of Clinical Data and Review Strategy.

Review of Safety Database

Overall Exposure

The safety population included all 115 subjects who received at least one dose of posaconazole. The mean overall treatment duration was 20.6 days (median 22 and range 1-28 days) for both POS IV and POS PFS with a mean duration of exposure of POS IV of 14.3 days (median 13 range 1-28 days) and of POS PFS of 11.6 days (median 10 days, range 2-18 days). All 115 subjects were dosed with IV solution of whom 109 (94.8%) received at least 7 days of therapy. Sixty-three subjects were transitioned to POS PFS of whom 57 (90.5%) received at least 7 days of therapy.

Adequacy of Safety Database

The size of the safety database in Study P097 was considered adequate although relatively small (N = 115 patients) to assess the safety of posaconazole in pediatric patients aged 2 to less than 18 years of age. Additional relevant safety data for the delayed-release tablet from the invasive aspergillosis treatment trial in pediatric patients were limited to 3 subjects aged 14 to 17 years.

Only 49 (43%) of the 115 subjects received the proposed dose for marketing of 6mg/kg (20 in group 1 and 29 in group 2) with a cap of 300mg per dose.

Adequacy of Applicant’s Clinical Safety Assessments

Categorization of Adverse Events:

Definitions of adverse events (AEs) and serious adverse events (SAEs) in the clinical protocol were standard regulatory definitions. Summary of all AEs is included in Table 11-3. Adverse events were coded using MedDRA version 21.0. Treatment emergent AEs (TEAEs) were those occurring from day 1 of study drug to those occurring up to 14 days after the last dose of the study drug. Study Days are numbered from the first day of IV treatment.

SAEs defined as any AE occurring at any dose or during any use of study drug that results in death, is life-threatening, results in persistent or significant disability/incapacity, results in or prolonged an existing inpatient hospitalization, is a congenital anomaly/birth defect, is another important medical event, is a new cancer, is associated with an overdose. Progression of cancer while on study drug was not considered an adverse event unless it resulted in hospitalization or death (unless outside of AE reporting period – through 14 days following cessation of treatment). Any grade 3 or 4 leukopenia, absolute neutropenia, or thrombocytopenia or any grade 1, 2, or 3 decrease in hemoglobin were not considered a serious adverse event.

The Coding dictionary used by the Applicant and translation of verbatim terms to PTs was deemed appropriate by the reviewer.

AEs occurred in 98% subjects (113 out of 115 subjects).

Reviewer’s Comment: *In several analyses, PTs were pooled into group query terms by the reviewer for more accurate analysis, e.g. elevated liver tests included elevated AST, elevated ALT, and elevated transaminases. Details are specified in footnotes of corresponding tables with pooled PTs marked and noted by an asterisk.*

Table 11-2: Summary of Adverse Events by Age and Dose Cohorts

	3.5 mg/kg: Age Group 1 (2-<7) n=14 (%)	3.5 mg/kg: Age Group 2 (7-17) n=21(%)	4.5 mg/kg: Age Group 1 (2-<7) n=15 (%)	4.5 mg/kg: Age Group 2 (7-17) n=16 (%)	6 mg/kg: Age Group 1 (2-<7) n=20 (%)	6 mg/kg: Age Group 2 (7-17) n=29 (%)	Totals n=115(%)
Subjects with at least 1 TEAE	13 (93)	21 (100)	15 (100)	16 (100)	19 (95)	29 (100)	113 (98)
Subjects with TEAE Drug Discontinuation	3 (21)	3 (14)	0	2 (13)	4 (20)	6 (21)	18 (16)
Subject with TEAE leading to Death	0	0	0	0	0	2 (7)	2 (2)
Subjects with at least 1 SAE	3 (21)	8 (38)	4 (27)	5 (31)	3 (15)	8 (28)	31 (27)

NDA Multi-disciplinary Review and Evaluation, sNDA 205596, 205053, 214770
 NOXAFIL® (posaconazole) injection, delayed release tablet, PowderMix
 For prophylaxis of invasive fungal infections in pediatric patients 2 years of age and older
 For treatment of invasive aspergillosis in adults and pediatric patients 13 years and older

	3.5 mg/kg: Age Group 1 (2-<7) n=14 (%)	3.5 mg/kg: Age Group 2 (7-17) n=21(%)	4.5 mg/kg: Age Group 1 (2-<7) n=15 (%)	4.5 mg/kg: Age Group 2 (7-17) n=16 (%)	6 mg/kg: Age Group 1 (2-<7) n=20 (%)	6 mg/kg: Age Group 2 (7-17) n=29 (%)	Totals n=115(%)
Subjects with SAE leading to Death	0	0	0	0	0	2 (7)	2 (2)
Subjects with SAE Drug Discontinuation	2 (14)	2 (10)	0	1 (6)	2 (10)	3 (10)	10 (9)

Source: Reviewer's Analysis (Analysis Studio)

Routine Clinical Tests

Per protocol, hematology and chemistry laboratory tests were collected and included at each visit.

Safety Results

Deaths

There were four deaths in the study. Two of these deaths were thought to be due to patients' underlying malignancy but were not reported as AEs since they occurred outside of the AE study drug monitoring period (greater than 14 days after the last dose was given). The other two deaths that were reported as AEs (1.7%) both occurred in the 6mg/kg Age Group 2 (7-17 year old) dose cohort.

Reviewer's Comment: *The exclusion of the two deaths occurring due to progression of the underlying malignancy would be considered a deviation from initial protocol had these occurred within the AE monitoring period. Since they occurred greater than 14 days after the last dose of study drug, their exclusion from adverse event categorization is reasonable.*

One of the two deaths reported as an adverse event was a 10 year old Hispanic white male with ALL and HTN who recently underwent HSCT (exact date unknown) and died of grade 5 venoocclusive disease (VOD) on Day 30. This subject had received 6 days of POS IV therapy before it was discontinued. He developed two SAEs: grade 4 capillary leak VOD on Day 6.

Reviewer's Comment: *Although the patient's death occurred on Day 30, well after drug discontinuation on Day 6, and it is most likely that patient's VOD was multifactorial and primarily related to his recent HSCT, POS-related causality cannot be definitely excluded as he developed VOD on Day 5 which ultimately was determined to be his cause of death while on POS.*

The second death occurred in a 16-year-old African American male who was post-HSCT (exact date unknown) and developed two serious adverse events: grade 3 stomatitis on Day 1 and

grade 5 respiratory failure on Day 19. His cause of death was determined to be respiratory failure (grade 6) on Day 49. On Day 6, the patient received his last dose of POS IV and was started on amphotericin due to neutropenic fever. On Day 18, his febrile neutropenia resolved. On Day 19, the subject developed respiratory distress with tachypnea, increased work of breathing, and hypoxia, requiring increasing respiratory support. He was diagnosed with respiratory failure and transferred to the PICU where he was noted to have bilateral multifocal lung opacities as well as a pericardial effusion and he died due to respiratory failure on Day 49.

Reviewer's Comment: *As the subject's respiratory status stabilized on Day 3 (enough to be de-escalated from PICU) and the study drug was discontinued on Day 6, his death due to recurrent respiratory failure on Day 49 (originally occurring 13 days post drug discontinuation on Day 19), is unlikely to be drug-related.*

Serious Adverse Events

Overall, 27% of subjects had serious adverse events (SAEs), 10 (9%) of which led to study drug discontinuation. The most common SAE was febrile neutropenia.

Serious adverse events for all dose cohorts listed by PT in descending order of incidence for those occurring in the 6mg/kg dose cohort are summarized in Table 11-4:

Table 11-3 Serious Adverse Events listed by PT in Descending Order of Incidence in 6mg/kg Dose Cohort

Preferred Term	Dose Cohort			
	3.5mg/kg (N=35)	4.5mg/kg (N=31)	6mg/kg (N=49)	Total (N=115)
	n (%)	n (%)	n (%)	n(%)
Febrile neutropenia	1 (3)	0	2 (4)	3 (3)
Vomiting	0	0	2 (4)	2 (2)
Venoocclusive disease	1 (3)	0	1 (2)	2(2)
Abdominal pain	0	0	1 (2)	1 (1)
Acute kidney injury	0	0	1 (2)	1 (1)
Capillary leak syndrome	0	0	1 (2)	1 (1)
Device related infection	0	0	1 (2)	1 (1)
Hypertension	0	0	1 (2)	1 (1)
Parainfluenzae virus infection	0	0	1 (2)	1 (1)
Posterior reversible encephalopathy syndrome	0	0	1 (2)	1 (1)
Respiratory failure	0	0	1 (2)	1 (1)
Stomatitis	0	0	1 (2)	1 (1)
Transplant rejection	0	0	1 (2)	1 (1)
Urinary tract infection viral	0	0	1 (2)	1 (1)
Cardiomyopathy	0	1 (3)	0	1 (1)
Chest wall haematoma	0	1 (3)	0	1 (1)
Engraftment syndrome	0	1 (3)	0	1 (1)
Fungal infection	0	1 (3)	0	1 (1)
Hypoxia	0	1 (3)	0	1 (1)
Pneumonia viral	0	1 (3)	0	1 (1)
Presyncope	0	1 (3)	0	1 (1)

Preferred Term	3.5mg/kg	4.5mg/kg	6mg/kg	Total
	(N=35)	(N=31)	(N=49)	(N=115)
	n (%)	n (%)	n (%)	n(%)
Streptococcal sepsis	0	1 (3)	0	1 (1)
Systemic mycosis	0	1 (3)	0	1 (1)
Thrombophlebitis superficial	0	1 (3)	0	1 (1)
Upper respiratory tract infection	0	1 (3)	0	1 (1)
Venoocclusive liver disease	0	1 (3)	0	1 (1)
Pyrexia	2 (6)	0	0	1 (1)
Acute respiratory distress syndrome	1 (3)	0	0	1 (1)
Adenovirus infection	1 (3)	0	0	1 (1)
Cardiac failure	1 (3)	0	0	1 (1)
Clostridium difficile colitis	1 (3)	0	0	1 (1)
Cystitis	1 (3)	0	0	1 (1)
Drug hypersensitivity	1 (3)	0	0	1 (1)
Enterobacter infection	1 (3)	0	0	1 (1)
Hepatic lesion	1 (3)	0	0	1 (1)
Herpes zoster	1 (3)	0	0	1 (1)
Hyponatraemia	1 (3)	0	0	1 (1)
Pneumonia	1 (3)	0	0	1 (1)
Renal failure	1 (3)	0	0	1 (1)
Source: OCS Analysis Studio, AutoSafety Tool.				
Filters: TRTFL = "Y" (Subjects); TRTEMFL = "Y" and AESER = "Y" (Adverse Events).				

Case narratives for selected patients with SAEs are summarized below:

A 6- year-old white Hispanic/Latino male with myelodysplastic syndrome in Age Group 1 of 4.5mg/kg dose cohort underwent treatment for 21 days (11 IV and 10 PFS) and had 4 SAEs (viral pneumonia (PNA) x 2 (grade 1 on day 16 due to parainfluenza III and grade 3 due to influenza on day 97) febrile neutropenia (grade 3; day 50), and PNA (grade 3; day 80 – treated and resolved with oxacillin and clindamycin). Patient became febrile while neutropenic requiring empiric antibiotics starting on day 36 with diagnosis of SAE of febrile neutropenia on day 50.

Reviewer's comment: *As all of these AEs occurred following discontinuation of the study drug and either resolved with supportive care and/or antibiotic administration, none of them were thought to be related to the study drug.*

A 12-year-old white, Hispanic/Latino male with acute promyelocytic leukemia in Age Group 2 of 4.5mg/kg dose cohort underwent treatment for 8 days (8 IV and 0 PFS) and had 2 SAEs (grade 3 fungal infection on day 7 and grade 3 febrile neutropenia on Day 64). This patient was already undergoing therapy with dipyrone (-14 to -14;-3 to -3; -2 to -2; 1 to 1), cefepime (-14 to -7), meropenem (-3 to 15), and vancomycin (-3 to 1) for febrile neutropenia and was hospitalized on Day -15. On Day 7, the subject experienced fever without a focalized source leading to the presumptive diagnosis of invasive fungal infection. On Day 8 the subject had the non-SAE of skin nodules in the thorax and right knee and was diagnosed with non-SAE of grade 3 febrile

neutropenia? Amphotericin B and linezolid were started for the suspected fungal infection with the last dose of study drug given on Day 8 with resolution of fever followed by initiation of voriconazole on Day 12 and resolution of chest nodules on Day 53 and resolution of skin nodules on Day 160.

A 14-year-old male (multiracial and Hispanic or Latino ethnicity) with acute promyelocytic leukemia in Age Group 2 of 4.5mg/kg dosing cohort underwent 7 total days of therapy and experienced grade 3 SAE of systemic mycosis (Day 11) and grade 1 pyrexia that led to discontinuation (Day 4) (see subsection of this section on significant adverse events relating to systemic fungal infections for more information).

A 16-year-old white Hispanic or Latino female experienced grade 3 vomiting as a serious adverse event on Day 21 out of 28 of study treatment duration that appears to be more related to the timing of her chemotherapy than the study drug itself. As the AE occurred during treatment with study drug, relation to the treatment cannot be definitively concluded.

A 10- year-old Asian male of non-Hispanic or Latino ethnicity with neuroblastoma and s/p stem cell transplant underwent 21 days of therapy (Age Group 2, 6mg/kg dose cohort) and experienced a SAE of grade 3 hypertension on Day 31 (s/p discontinuation of study drug); therefore, this SAE is unlikely to be related. Additionally, the patient had a preexisting condition of hypertension before entering the study which was treated with hydralazine and isradipine and resolved on Day 34 following other anti-hypertensive interventions.

A 12-year-old female (white, not Hispanic or Latino) with metastatic Ewing's sarcoma, myelodysplastic syndrome, Age Group 2 in 6mg/kg dosing cohort underwent 28 days of therapy and experienced two SAEs (parainfluenza virus grade 3 on Day 27 and viral UTI grade 3 on Day 29) unrelated to study drug.

A 15-year-old white, not Hispanic or Latino, male with Hodgkin's disease s/p stem cell transplant in Age Group 2 in the 3.5mg/kg dose cohort underwent 28 days of therapy and experienced one SAE on Day 32 of herpes zoster grade 3 following discontinuation of study drug and while patient was undergoing significant immunosuppressive therapy with skin lesions that resolved following acyclovir administration by Day 44.

An 11- year- old white female (not Hispanic or Latino) with ALL s/p stem cell transplant in Age Group 2, 3.5mg/kg dosing cohort, underwent 28 days of therapy and experienced grade 1 SAE of pyrexia on dDay 27. Fever was reported at home, and the patient was afebrile without treatment upon admission to hospital. Remained afebrile without any antibiotics or antipyretics administered, and no action taken. The fever unlikely related to study drug.

A 9- year -old white, not Hispanic or Latino, female with myelodysplastic syndrome s/p stem cell transplant underwent 12 days of therapy (6mg/kg , Age Group 2) and experienced a SAE of

NDA Multi-disciplinary Review and Evaluation, sNDA 205596, 205053, 214770
NOXAFIL® (posaconazole) injection, delayed release tablet, PowderMix
For prophylaxis of invasive fungal infections in pediatric patients 2 years of age and older
For treatment of invasive aspergillosis in adults and pediatric patients 13 years and older

transplant rejection grade 3 occurring on Day 11 that led to discontinuation of study drug.

A 3-year-old white male (not Hispanic or Latino) with aplastic anemia in Age Group 1 (3.5mg/kg dose cohort) underwent 23 days of therapy with grade 3 SAE of hyponatremia occurring on Day 26, therefore unlikely related to study drug.

A 4- year- old white, not Hispanic or Latino, male (Age Group 1, 4.5mg/kg dose cohort) with neuroblastoma, s/p stem cell transplant (autologous PBSCT on day 3) who underwent central venous catheter placement and 20 days total of study treatment experienced a SAE of grade 3 veno-occlusive liver disease on Day 30. Day 38 event resolved following multiple therapies, unlikely related to study drug.

A 16 -year- old white female (not Hispanic or Latino) in Age Group 2 of 3.5mg/kg dosing cohort with Ewing's sarcoma (recurrent) s/p stem cell transplant developed a SAE of *C. difficile* colitis (grade 3 occurring on Day 10), febrile neutropenia grade 3 (occurring on Day 13), and cystitis grade 3 occurring on Day 30 who underwent 26 days of study drug treatment.

An 11- year- old white, not Hispanic or Latino, female with recurrent Ewing's sarcoma s/p stem cell transplant in Age Group 2 of 3.5mg/kg dose cohort underwent 11 days of therapy and experienced a grade 3 SAE of hepatic lesion on Day 11 that led to discontinuation of study drug.

A 4 -year- old white, not Hispanic or Latino, male with aplastic anemia and a liver disorder (unspecified), age group 1 of 6mg/kg dose cohort who underwent 20 days of treatment and experienced grade 4 SAE of febrile neutropenia (day 14), grade 4 posterior reversible encephalopathy syndrome on day 20 that led to discontinuation of study drug.

A 3-year-old white, not Hispanic or Latino male with acute leukemia (unspecified) and history of emesis; age group 1 of 6mg/kg dose cohort who underwent 13 days of therapy experienced SAE of vomiting grade 3 on day 26; therefore, the AE is unlikely related to study drug.

A 10-year-old white, not Hispanic or Latino male in Age Group 2 of 6mg/kg dose cohort with acute leukemia who underwent 28 days of therapy experienced a grade 3 SAE febrile neutropenia on Day 36; therefore, the SAE is unlikely related to study drug.

Reviewer's Comments:

Dropouts and/or Discontinuations Due to Adverse Effects

Error! Reference source not found. summarizes the TEAEs leading to study drug discontinuation by age and dose across all cohorts.

Table 11-4 TEAEs leading to Study Drug Discontinuation

	Treatment 3.5 mg/kg		Treatment 4.5 mg/kg		Treatment 6 mg/kg		Total	
	2-<7 (N=14)	7-17 (N=21)	2-<7 (N=15)	7-17 (N=16)	2-<7 (N=19)	7-17 (N=30)	2-<7 (N=48)	7-17 (N=67)
DRUG WITHDRAWN	3 (21)	3 (14)	0	2 (13)	4 (21)	6 (20)	7 (15)	11 (16)
Pyrexia	0	1 (5)	0	1 (6.)	1 (5)	0	1 (2)	2 (3)
Veno-occlusive disease	1 (7)	0	0	0	0	1 (3)	1 (2)	1 (2)
Abdominal pain	0	0	0	0	1 (5)	0	1 (2.1)	0
Acute kidney injury	0	0	0	0	0	1 (3)	0	1 (2)
Acute myeloid leukemia	0	0	0	0	0	1 (3)	0	1 (2)
Acute respiratory distress syndrome	0	1 (5)	0	0	0	0	0	1 (2)
Alanine aminotransferase increased	0	0	0	0	0	1 (3)	0	1 (2)
Aspartate aminotransferase increased	0	0	0	0	0	1 (3)	0	1 (2)
Blood bilirubin increased	1 (7)	0	0	0	0	0	1 (2)	0
Drug hypersensitivity	1 (7)	0	0	0	0	0	1 (2)	0
Electrocardiogram QT prolonged	0	0	0	0	0	1 (3)	0	1 (2)
Epistaxis	1 (7)	0	0	0	0	0	1 (2)	0
Fungal infection	0	0	0	1 (6)	0	0	0	1 (2)
Hepatic lesion	0	1 (5)	0	0	0	0	0	1 (2)
Posterior reversible encephalopathy syndrome	0	0	0	0	1 (5)	0	1 (2)	0
Rash	0	0	0	0	1 (5.)	0	1 (2)	0
Transplant rejection	0	0	0	0	0	1 (3)	0	1 (2)

Source: Reviewer's Analysis (Analysis Studio)

Table 11-6 below includes TEAEs by pooled (group query) and preferred terms leading to drug discontinuation for total 6mg/kg dose cohort by age.

Table 11-5 Treatment Emergent Adverse by Age Group Leading to Study Drug Discontinuation (Pooled Analysis, for 6 mg/kg Dose Cohort)

	6 mg/kg: Age Group 1 (2-<7 years old) n=20 (%)	6 mg/kg: Age Group 2 (7-17 years old) n=29 (%)	Total Study population (3 dose cohorts) n=115 (%)
Subjects with at least 1 TEAE leading to drug discontinuation - count subjects and % with data	4 (20.0%)	6 (20.7%)	18 (15.7%)
*Fever	1 (5.0%)	0	3 (2.6%)
Pyrexia	1 (5.0%)	0	3 (2.6%)
Veno-occlusive disease	0	1 (3.4%)	2 (1.7%)
Veno-occlusive disease	0	1 (3.4%)	2 (1.7%)

	6 mg/kg: Age Group 1 (2-<7 years old) n=20 (%)	6 mg/kg: Age Group 2 (7-17 years old) n=29 (%)	Total Study population (3 dose cohorts) n=115 (%)
Acute respiratory distress syndrome	0	0	1 (0.9%)
Acute respiratory distress syndrome	0	0	1 (0.9%)
Hepatic lesion	0	0	1 (0.9%)
Hepatic lesion	0	0	1 (0.9%)
Epistaxis	0	0	1 (0.9%)
Epistaxis	0	0	1 (0.9%)
*Fungal infection	0	0	1 (0.9%)
Fungal infection	0	0	1 (0.9%)
*Abdominal pain	1 (5.0%)	0	1 (0.9%)
Abdominal pain	1 (5.0%)	0	1 (0.9%)
*Hyperbilirubinaemia	0	0	1 (0.9%)
Blood bilirubin increased	0	0	1 (0.9%)
*Rash	1 (5.0%)	0	1 (0.9%)
Rash	1 (5.0%)	0	1 (0.9%)
Posterior reversible encephalopathy syndrome	1 (5.0%)	0	1 (0.9%)
Posterior reversible encephalopathy syndrome	1 (5.0%)	0	1 (0.9%)
*Acute kidney injury	0	1 (3.4%)	1 (0.9%)
Acute kidney injury	0	1 (3.4%)	1 (0.9%)
*Elevated LFTs	0	1 (3.4%)	1 (0.9%)
Alanine aminotransferase increased	0	1 (3.4%)	1 (0.9%)
Aspartate aminotransferase increased	0	1 (3.4%)	1 (0.9%)
*Graft failure	0	1 (3.4%)	1 (0.9%)
Transplant rejection	0	1 (3.4%)	1 (0.9%)
Acute myeloid leukaemia	0	1 (3.4%)	1 (0.9%)
Acute myeloid leukaemia	0	1 (3.4%)	1 (0.9%)
Electrocardiogram QT prolonged	0	1 (3.4%)	1 (0.9%)
Electrocardiogram QT prolonged	0	1 (3.4%)	1 (0.9%)
*Drug hypersensitivity	0	0	1 (0.9%)
Drug hypersensitivity	0	0	1 (0.9%)

Source: Reviewer's analysis (JReview)

Eighteen subjects (16%) experienced adverse events leading to discontinuations. The most common reason for discontinuation being pyrexia in 3 subjects followed by VOD in 2 subjects. One of these was a subject in age group 2 of 6mg/kg cohort who experienced QT prolongation from 386 to 430 ms on day 14 with resolution 9 days later. This patient had been diagnosed with the AE of endocarditis on day 4 with concurrent AEs of hypocalcemia, hypokalemia, and hypomagnesemia. His steady-state Cavg POS concentration was 3060ng/mL while on IV POS.

NDA Multi-disciplinary Review and Evaluation, sNDA 205596, 205053, 214770
NOXAFIL® (posaconazole) injection, delayed release tablet, PowderMix
For prophylaxis of invasive fungal infections in pediatric patients 2 years of age and older
For treatment of invasive aspergillosis in adults and pediatric patients 13 years and older

Reviewer's Comment: *As the patient's QT prolongation occurred while the patient was on the study drug with a Cavg exceeding the specified max of 2500ng/mL, we cannot exclude drug related causality in a setting of concurrent metabolic electrolyte abnormalities.*

Another subject in the 6mg/kg cohort from age group 2 experienced the adverse events of both increased ALT and increased AST, but this patient had a history of abnormal liver function tests with elevated ALT and AST at baseline that increased to Grade 3 on day 2 of IV POS, requiring discontinuation on the same day, and resolved by day 18. There is no POS Cavg value for this subject since the subject discontinued the study treatment prior to the steady-state PK sampling visit.

Reviewer's Comment: *Although this patient had abnormal baseline values of LFTs, the rapid rise in these levels while on the study drug cannot be excluded particularly without knowing the Cavg value of POS in this patient.*

Another patient of the 3.5mg/kg Age Group 1 cohort experienced epistaxis on Day 2 of IV POS (which was discontinued on day 8) and resolved by day 11 who had a steady-state Cavg POS concentration of 449 ng/mL while on IV POS.

A 3 year old Asian (not Hispanic or Latino) male with thalassemia, post stem-cell transplant, who was part of 3.5mg/kg and age group 1 cohorts underwent 8 days of total therapy (all IV) and experienced a grade 3 drug hypersensitivity on day 4 of treatment determined to be a SAE as well as epistaxis on day 2. As both AEs were thought to be related to the study drug by the investigator, these adverse events led to discontinuation of the study drug on day 8.

Reviewer's Comment: *This AE is unlikely related to study drug in setting of study drug with Cavg below the recommended Cavg of 500ng/mL, however given the timing of the onset of the AE upon initiation of the study drug and resolution following discontinuation, an association cannot be completely excluded.*

The adverse event of rash occurred in a subject in the 6mg/kg Age Group 1 dose cohort which began on Day 1 of the study treatment (which was discontinued on Day 12). The adverse event resolved by Day 14 and the patient's steady-state Cavg POS concentration was 1760 ng/mL while on IV POS.

Reviewer's Comment: *The rash appeared on Day 1 of the study drug administration and resolved only 2 days following discontinuation of the drug (Day 14). Positive dechallenge suggests possible relationship to POS.*

Another patient in the 3.5mg/kg age group 1 dosing cohort had an increase in total bilirubin from 6.8mmol micromol/L on Day 1 to 63 micromol/L (Grade 2) on Day 3. Patient was transfused RBCs from day 2 to 3 and on day 6, (prior to study drug discontinuation on Day 7), the total bilirubin trended down to 42.75 micromol/L.

Reviewer's Comment: Given that the total serum bilirubin decreased to 41.75 micromol/L on Day 6 (from its peak elevation to Grade 2 toxicity of 63mmol/L on Day 3) prior to study drug discontinuation, the drug related causality for Tbili elevation is less likely. Additionally, the patient was transfused RBCs from Day 2 to 3 which is likely to have contributed at least in part to the rise in total bilirubin.

Significant Adverse Events

Error! Reference source not found. summarizes TEAEs by maximum severity/toxicity grading in the three cohorts (3.5mg/kg, 4.5mg/kg, 6mg/kg) and by descending order in the 6mg/kg cohort

Pruritis, hypokalemia, AST and ALT elevations, thrombocytopenia, hypophosphatemia, hypoalbuminemia, (and oropharyngeal pain, myalgia, and dry eye) show increasing frequency in overall toxicity and in grade 3 to 5 specific toxicity with increasing dose.

Table 11-6 Summary of TEAEs by Maximum Severity-Toxicity by Dose Cohort occurring in >5% of Study Subjects

Preferred Term	3.5mg/kg (N=35)			4.5mg/kg (N=31)			6mg/kg (N=49)		
	Grade 1 to 5	Grade 3 to 5	Grade 5	Grade 1 to 5	Grade 3 to 5	Grade 5	Grade 1 to 5	Grade 3 to 5	Grade 5
	n (%)	n (%)	n (%)	n (%)	n (%)	n (%)	n (%)	n (%)	n (%)
Pyrexia	18 (51.4)	1 (2.9)	0	1 6 (51.6)	0	0	16 (32.7)	1 (2.0)	0
Febrile neutropenia	6 (17.1)	4 (11.4)	0	4 (12.9)	3 (9.7)	0	15 (30.6)	11 (22.4)	0
Vomiting	10 (28.6)	0	0	8 (25.8)	0	0	12 (24.5)	2 (4.1)	0
Mucosal inflammation	12 (34.3)	2 (5.7)	0	9 (29.0)	5 (16.1)	0	11 (22.4)	3 (6.1)	0
Pruritus	1 (2.9)	0	0	6 (19.4)	0	0	11 (22.4)	0	0
Hypokalemia	2 (5.7)	0	0	4 (12.9)	1 (3.2)	0	10 (20.4)	5 (10.2)	0
Hypertension	7 (20.0)	0	0	3 (9.7)	0	0	10 (20.4)	2 (4.1)	0
Stomatitis	2 (5.7)	1 (2.9)	0	1 (3.2)	1 (3.2)	0	10 (20.4)	7 (14.3)	0
Diarrhea	7 (20.0)	0	0	9 (29.0)	1 (3.2)	0	9 (18.4)	1 (2.0)	0
Nausea	5 (14.3)	1 (2.9)	0	4 (12.9)	0	0	9 (18.4)	0	0
Abdominal pain	4 (11.4)	0	0	8 (25.8)	1 (3.2)	0	8 (16.3)	1 (2.0)	0
Rash	6 (17.1)	1 (2.9)	0	5 (16.1)	0 (0.0)	0	7 (14.3)	0	0
Decreased appetite	6 (17.1)	2 (5.7)	0	4 (12.9)	1 (3.2)	0	7 (14.3)	2 (4.1)	0
Headache	5 (14.3)	0	0	5 (16.1)	0	0	6 (12.2)	0	0
Alanine aminotransferase increased	1 (2.9)	1 (2.9)	0	1 (3.2)	0	0	6 (12.2)	2 (4.1)	0
Aspartate aminotransferase increased	1 (2.9)	0	0	2 (6.5)	0	0	5 (10.2)	2 (4.1)	0
Epistaxis	3 (8.6)	1 (2.9)	0	6 (19.4)	0	0	4 (8.2)	0	0
Anemia	2 (5.7)	2 (5.7)	0	4 (12.9)	3 (9.7)	0	4 (8.2)	2 (4.1)	0
Constipation	5 (14.3)	0	0	3 (9.7)	2 (6.5)	0	4 (8.2)	0	0
Hypomagnesaemia	3 (8.6)	0	0	3 (9.7)	0	0	4 (8.2)	0	0
Back pain	1 (2.9)	0	0	3 (9.7)	0	0	4 (8.2)	0	0

Preferred Term	3.5mg/kg (N=35)			4.5mg/kg (N=31)			6mg/kg (N=49)		
	Grade 1 to 5	Grade 3 to 5	Grade 5	Grade 1 to 5	Grade 3 to 5	Grade 5	Grade 1 to 5	Grade 3 to 5	Grade 5
	n (%)	n (%)	n (%)	n (%)	n (%)	n (%)	n (%)	n (%)	n (%)
Abdominal pain upper	3 (8.6)	0	0	2 (6.5)	0	0	4 (8.2)	2 (4.1)	
Erythema	1 (2.9)	0	0	2 (6.5)	0	0	4 (8.2)	0	
Hypophosphatemia	0 (0.0)	0	0	1 (3.2)	0	0	4 (8.2)	0	
Drug hypersensitivity	1 (2.9)	1 (2.9)	0	0 (0.0)	0	0	4 (8.2)	1 (2.0)	
Hypoalbuminemia	0 (0.0)	0	0	0 (0.0)	0	0	4 (8.2)	0	
Cough	2 (5.7)	0	0	5 (16.1)	0	0	3 (6.1)	0	
Cytomegalovirus infection	0 (0.0)	0	0	4 (12.9)	0	0	3 (6.1)	1 (2.0)	
Thrombocytopenia	2 (5.7)	1 (2.9)	0	2 (6.5)	1 (3.2)	0	3 (6.1)	2 (4.1)	
Hypotension	0 (0.0)	0	0	2 (6.5)	0	0	3 (6.1)	0	
Epstein-Barr virus infection	2 (5.7)	0	0	1 (3.2)	0	0	3 (6.1)	1 (2.0)	
Graft versus host disease in skin	2 (5.7)	2 (5.7)	0	1 (3.2)	0	0	3 (6.1)	0	
Platelet count decreased	1 (2.9)	1 (2.9)	0	1 (3.2)	1 (3.2)	0	3 (6.1)	3 (6.1)	
Oropharyngeal pain	1 (2.9)	0	0	1 (3.2)	0	0	3 (6.1)	0	
Myalgia	1 (2.9)	0	0	1 (3.2)	0	0	3 (6.1)	0	
Dry eye	1 (2.9)	0	0	1 (3.2)	0	0	3 (6.1)	0	
Edema peripheral	1 (2.9)	0	0	0 (0.0)	0	0	3 (6.1)	0	

Source: Reviewer's Analysis (Analysis Studio)

Treatment Emergent Adverse Events and Adverse Reactions

The most common adverse events overall were fever, mucositis, rash, vomiting, abdominal pain, musculoskeletal pain, diarrhea, elevated LFTs, hypertension, pruritis, decreased appetite, hypokalemia, nausea, headache, GVHD, epistaxis, constipation, and thrombocytopenia. The most common TEAE by SOC were GI-related. There were two adverse events consistent with possible or probable IFI reported in 2 subjects (1.7%) during the study period. Both AEs occurred in Age Group 2 in the 4.5 mg/kg dose cohort one of whom experienced systemic mycosis starting on Day 11 as day fever without a clear source and follow up CT scans showing evidence of splenic and lung lesions likely of fungal etiology. POS IV had been discontinued on Day 7 due to pyrexia and investigator's decision to escalate therapy to include amphotericin B. A follow-up CT chest showed densities in spleen and lung suggestive of disseminated fungal infection and the patient was started on voriconazole. Patient continued on outpatient voriconazole and on Day 94 systemic mycosis resolved and outpatient voriconazole stopped.

The other subject's fungal infection started on Day 7 as fever and skin nodules after which the subject was started on amphotericin B and POS IV was discontinued on day 8. Following addition of voriconazole and continued chemotherapy and outpatient voriconazole with complete resolution on Day 160. Both subjects had POS Cavg concentrations within the target therapeutic range (1190ng/mL and 1180ng/mL) compared to the mean of Cavg 1240ng/mL for this age group. Both adverse events were resolved by the end of the study follow-up period.

NDA Multi-disciplinary Review and Evaluation, sNDA 205596, 205053, 214770
 NOXAFIL® (posaconazole) injection, delayed release tablet, PowderMix
 For prophylaxis of invasive fungal infections in pediatric patients 2 years of age and older
 For treatment of invasive aspergillosis in adults and pediatric patients 13 years and older

Error! Reference source not found. summarizes the most common TEAE by pooled (group query) term and dose and age cohort descending by the total down to >5%. Highlighted are the remarkable labs in the 6mg/kg dosing cohort, all of which are higher in the older age group other than anemia.

Table 11-7 TEAEs by pooled Preferred Term and Dose and Age Cohort in > 5% Study Subjects

TEAEs	Treatment 3.5 mg/kg:		Treatment 4.5 mg/kg:		Treatment 6 mg/kg		Totals N=115 n (%)
	Group 1 (2-<7 y) N=14 n (%)	Group 2 (7-17 y) N=21 n (%)	Group 1 (2-<7 y) N=15 n (%)	Group 2 (7-17 y) N=16 n (%)	Group 1 (2-<7 y) N=20 n (%)	Group 2 (7-17 y) N=29 n (%)	
Subjects with at least 1 TEAE	13 (92.9%)	21 (100.0%)	15 (100.0%)	16 (100.0%)	19 (95.0%)	29 (100.0%)	113 (98.3%)
*Fever	10 (71.4%)	13 (61.9%)	6 (40.0%)	12 (75.0%)	12 (60.0%)	14 (48.3%)	67 (58.3%)
*Mucositis	3 (21.4%)	11 (52.4%)	6 (40.0%)	5 (31.3%)	10 (50.0%)	14 (48.3%)	49 (42.6%)
*Rash	4 (28.6%)	7 (33.3%)	5 (33.3%)	5 (31.3%)	7 (35.0%)	5 (17.2%)	33 (28.7%)
Vomiting	4 (28.6%)	6 (28.6%)	2 (13.3%)	6 (37.5%)	6 (30.0%)	6 (20.7%)	30 (26.1%)
*Abdominal pain	3 (21.4%)	4 (19.0%)	4 (26.7%)	6 (37.5%)	5 (25.0%)	7 (24.1%)	29 (25.2%)
*Musculoskeletal pain	2 (14.3%)	6 (28.6%)	3 (20.0%)	7 (43.8%)	2 (10.0%)	6 (20.7%)	26 (22.6%)
Diarrhea	5 (35.7%)	2 (9.5%)	5 (33.3%)	4 (25.0%)	5 (25.0%)	4 (13.8%)	25 (21.7%)
Hypertension	5 (35.7%)	2 (9.5%)	2 (13.3%)	1 (6.3%)	6 (30.0%)	4 (13.8%)	20 (17.4%)
*Hypokalemia	3 (21.4%)	2 (9.5%)	1 (6.7%)	4 (25.0%)	3 (15.0%)	7 (24.1%)	20 (17.4%)
*Pruritus	0 (0.0%)	1 (4.8%)	1 (6.7%)	5 (31.3%)	5 (25.0%)	8 (27.6%)	20 (17.4%)
*Decrease appetite	3 (21.4%)	4 (19.0%)	4 (26.7%)	1 (6.3%)	4 (20.0%)	4 (13.8%)	20 (17.4%)
Nausea	1 (7.1%)	4 (19.0%)	1 (6.7%)	3 (18.8%)	2 (10.0%)	7 (24.1%)	18 (15.7%)
Headache	1 (7.1%)	4 (19.0%)	0 (0.0%)	5 (31.3%)	1 (5.0%)	5 (17.2%)	16 (13.9%)
*Graft versus host disease	2 (14.3%)	4 (19.0%)	0 (0.0%)	2 (12.5%)	2 (10.0%)	4 (13.8%)	14 (12.2%)
*Constipation	3 (21.4%)	2 (9.5%)	2 (13.3%)	1 (6.3%)	0 (0.0%)	5 (17.2%)	13 (11.3%)
Epistaxis	2 (14.3%)	1 (4.8%)	1 (6.7%)	5 (31.3%)	1 (5.0%)	3 (10.3%)	13 (11.3%)
*Thrombocytopenia	1 (7.1%)	2 (9.5%)	0 (0.0%)	3 (18.8%)	2 (10.0%)	4 (13.8%)	12 (10.4%)
*Hypomagnesaemia	2 (14.3%)	1 (4.8%)	2 (13.3%)	1 (6.3%)	1 (5.0%)	4 (13.8%)	11 (9.6%)
Anemia	1 (7.1%)	1 (4.8%)	1 (6.7%)	3 (18.8%)	2 (10.0%)	2 (6.9%)	10 (8.7%)

NDA Multi-disciplinary Review and Evaluation, sNDA 205596, 205053, 214770
 NOXAFIL® (posaconazole) injection, delayed release tablet, PowderMix
 For prophylaxis of invasive fungal infections in pediatric patients 2 years of age and older
 For treatment of invasive aspergillosis in adults and pediatric patients 13 years and older

TEAEs	Treatment 3.5 mg/kg:		Treatment 4.5 mg/kg:		Treatment 6 mg/kg:		Totals N=115 n (%)
	Group 1 (2-<7 y) N=14 n (%)	Group 2 (7-17 y) N=21 n (%)	Group 1 (2-<7 y) N=15 n (%)	Group 2 (7-17 y) N=16 n (%)	Group 1 (2-<7 y) N=20 n (%)	Group 2 (7-17 y) N=29 n (%)	
Subjects with at least 1 TEAE	13 (92.9%)	21 (100.0%)	15 (100.0%)	16 (100.0%)	19 (95.0%)	29 (100.0%)	113 (98.3%)
*Oxygen saturation decreased	1 (7.1%)	2 (9.5%)	1 (6.7%)	3 (18.8%)	1 (5.0%)	2 (6.9%)	10 (8.7%)
*Erythema	1 (7.1%)	1 (4.8%)	1 (6.7%)	1 (6.3%)	4 (20.0%)	2 (6.9%)	10 (8.7%)
Cough	2 (14.3%)	0 (0.0%)	4 (26.7%)	1 (6.3%)	0 (0.0%)	3 (10.3%)	10 (8.7%)
*Transfusion reaction	1 (7.1%)	1 (4.8%)	0 (0.0%)	3 (18.8%)	2 (10.0%)	1 (3.4%)	8 (7.0%)
Alanine aminotransferase increased	0 (0.0%)	1 (4.8%)	1 (6.7%)	0 (0.0%)	1 (5.0%)	5 (17.2%)	8 (7.0%)
*Edema	0 (0.0%)	2 (9.5%)	1 (6.7%)	0 (0.0%)	2 (10.0%)	3 (10.3%)	8 (7.0%)
Aspartate aminotransferase increased	0 (0.0%)	1 (4.8%)	1 (6.7%)	1 (6.3%)	0 (0.0%)	5 (17.2%)	8 (7.0%)
*Edema facial	2 (14.3%)	1 (4.8%)	0 (0.0%)	0 (0.0%)	0 (0.0%)	4 (13.8%)	7 (6.1%)
*Drug hypersensitivity	1 (7.1%)	0 (0.0%)	0 (0.0%)	0 (0.0%)	3 (15.0%)	3 (10.3%)	7 (6.1%)
Cytomegalovirus infection	0 (0.0%)	0 (0.0%)	3 (20.0%)	1 (6.3%)	1 (5.0%)	2 (6.9%)	7 (6.1%)
Transaminases increased	2 (14.3%)	1 (4.8%)	1 (6.7%)	3 (18.8%)	0 (0.0%)	0 (0.0%)	7 (6.1%)
*Oropharyngeal pain	0 (0.0%)	3 (14.3%)	1 (6.7%)	0 (0.0%)	0 (0.0%)	3 (10.3%)	7 (6.1%)
*Neutropenia	0 (0.0%)	2 (9.5%)	1 (6.7%)	0 (0.0%)	0 (0.0%)	3 (10.3%)	6 (5.2%)
Epstein-Barr virus infection	1 (7.1%)	1 (4.8%)	1 (6.7%)	0 (0.0%)	1 (5.0%)	2 (6.9%)	6 (5.2%)
*Skin lesion	3 (21.4%)	2 (9.5%)	0 (0.0%)	0 (0.0%)	1 (5.0%)	0 (0.0%)	6 (5.2%)
*Hyperbilirubinemia	1 (7.1%)	1 (4.8%)	1 (6.7%)	3 (18.8%)	0 (0.0%)	0 (0.0%)	6 (5.2%)
Tachycardia	1 (7.1%)	2 (9.5%)	1 (6.7%)	0 (0.0%)	1 (5.0%)	1 (3.4%)	6 (5.2%)
Veno-occlusive disease	3 (21.4%)	0 (0.0%)	1 (6.7%)	0 (0.0%)	0 (0.0%)	2 (6.9%)	6 (5.2%)
*Upper respiratory tract infection	0 (0.0%)	0 (0.0%)	3 (20.0%)	0 (0.0%)	1 (5.0%)	2 (6.9%)	6 (5.2%)

Source: Reviewer's analyses (JReview) custom group query Pooled terms marked with *

Error! Reference source not found. summarizes the most common TEAE by pooled preferred terms and dose cohort by descending order in the 6mg/kg group.

The most frequently reported adverse events (>20%) in the proposed 6mg/kg dose for marketing included fever and GI symptoms as in adults, but varied from adults in that there were significant numbers of mucocutaneous AE including mucositis, pruritis, and rash (49%, 26.5%, and 26.5% respectively), followed by reported hypokalemia (20.4%) and hypertension (20.4%). **Error! Reference source not found.** presents TEAEs (>10%) by pooling of preferred terms in descending order in the 6mg/kg dose cohort. Given the small sample size, pooled terms were created to group similar TEAEs to increase the precision of safety signal detection. **See footnotes** below for further details.

The most common TEAEs leading to discontinuation of posaconazole in the prophylaxis studies in pediatrics including all dose/age cohorts were fever (2.6%) followed by venocclusive disease (1.7%) varying from adult studies in which the most common adverse events leading to discontinuation were associated with GI disorders (nausea 2%, vomiting, 2%, and hepatic enzymes increased 2%)

Table 11-8 TEAEs by Pooled Preferred Terms in 6mg/kg Dose Cohort occurring in > 5% of Study Subjects

	6 mg/kg Dose Cohort	All Dose Cohorts
	n=49 (%)	n=115 (%)
Subjects with at least 1 TEAE	48 (98.0%)	113 (98.3%)
*Fever	26 (53.1%)	67 (58.3%)
*Mucositis	24 (49.0%)	49 (42.6%)
*Pruritus	13 (26.5%)	20 (17.4%)
*Rash	13 (26.5%)	34 (29.6%)
Vomiting	12 (24.5%)	30 (26.1%)
*Abdominal pain	12 (24.5%)	29 (25.2%)
*Hypokalemia	10 (20.4%)	20 (17.4%)
Hypertension	10 (20.4%)	20 (17.4%)
Nausea	9 (18.4%)	18 (15.7%)
Diarrhea	9 (18.4%)	25 (21.7%)
*Decrease appetite	8 (16.3%)	20 (17.4%)
*Musculoskeletal pain	8 (16.3%)	26 (22.6%)
*Edema	7 (14.3%)	11 (9.6%)
Headache	6 (12.2%)	16 (13.9%)
*Elevated LFTs	6 (12.2%)	16 (13.9%)
*Erythema	6 (12.2%)	10 (8.7%)
*Thrombocytopenia	6 (12.2%)	12 (10.4%)
*Drug hypersensitivity	6 (12.2%)	7 (6.1%)
*Hypomagnesemia	6 (12.2%)	12 (10.4%)
*Graft versus host disease	6 (12.2%)	14 (12.2%)
*Hypoalbuminemia	5 (10.2%)	6 (5.2%)
*Constipation	5 (10.2%)	13 (11.3%)

Source: Reviewer's analyses (JReview) custom group query
 Pooled terms are marked with *.

The Applicant requested to present the adverse reaction profile by the preferred term only (Table 11-10) to be consistent with the presentation for other clinical trials in the labeling.

Table 11-9 TEAEs by Preferred Term Occurring in > 5% of Study Subjects, P097

Treatment Emergent Adverse Events	3.5 mg/kg N=35 n (%)	4.5 mg/kg (N=31) n (%)	6 mg/kg (N=49) n (%)	All Dose Cohorts (N=115) n (%)
Pyrexia	18 (51)	16 (52)	16 (33)	50 (43)
Febrile neutropenia	6 (17)	4 (13)	15 (31)	25 (22)
Vomiting	10 (29)	8 (26)	12 (24)	30 (26)
Mucosal inflammation	12 (34)	9 (29)	11 (22)	32 (28)
Pruritus	1 (3)	6 (19)	11 (22)	18 (16)
Hypertension	7 (20)	3 (10)	10 (20)	20 (17)
Hypokalemia	2 (6)	4 (13)	10 (20)	16 (14)
Stomatitis	2 (6)	1 (3)	10 (20)	13 (11)
Diarrhea	7 (20)	9 (29)	9 (18)	25 (22)
Nausea	5 (14)	4 (13)	9 (18)	18 (16)
Abdominal pain	4 (11)	8 (26)	8 (16)	20 (17)
Decreased appetite	6 (17)	4 (13)	7 (14)	17 (15)
Rash	6 (17)	5 (16)	7 (14)	18 (16)
Alanine aminotransferase increased	1 (3)	1 (3)	6 (12)	8 (7)
Headache	5 (14)	5 (16)	6 (12)	16 (14)
Aspartate aminotransferase increased	1 (3)	2 (6)	5 (10)	8 (7)
Anemia	2 (6)	4 (13)	4 (8)	10 (9)
Constipation	5 (14)	3 (10)	4 (8)	12 (10)
Epistaxis	3 (9)	6 (19)	4 (8)	13 (11)
Cough	2 (6)	5 (16)	3 (6)	10 (9)
Cytomegalovirus infection	0	4 (13)	3 (6)	7 (6)
Graft versus host disease	4 (11)	1 (3)	1 (2)	6 (5)
Pain in extremity	3 (9)	4 (13)	1 (2)	8 (7)
Transaminases increased	3 (9)	4 (13)	0	7 (6)
Source: Reviewer's analyses; OCS Analysis Studio, Custom Table Tool. Columns - Dataset: Demographics; Filter: ACTARM = 'Posaconazole', TRTFL = 'Y'. Table Section 1 - Dataset: Adverse Events; Filter: TRTEMFL = 'Y'; Percent Threshold: >= 10%.				

(b) (6) A 3-year-old Asian male (Age Group 1) of the 3.5mg/kg cohort, experienced a SAE of grade 3 drug hypersensitivity on Day 4 of POS IV therapy resulting in subsequent drug discontinuation on Day 8 and the event resolved after 7 days. This subject also experienced grade 3 epistaxis, a non-SAE on Day 2 that lasted 9 days and was an additional reason behind

the study drug discontinuation. In this patient, the steady state Cavg concentration while on POS IV was 449ng/mL.

Laboratory Findings

Hepatic

ALT/AST: Approximately 50% of patients have experienced shifts in ALT and AST elevations postbaseline; these did not appear to be dose related.

As displayed in Tables 11-11 and 11-12 below shifts from grade 0-2 to grade 3 and 4 postbaseline occurred 3/49 (6%) and 2/49 (4%) pediatric patients in the 6 mg/kg dose group for ALT and AST, respectively compared to 6-17 % and 3-4% adults receiving POS oral suspension in IFI prophylaxis trials.

Table 11-10 Change from Baseline, ALT

Baseline ALT grade	Worst ALT Grade Postbaseline	Treatment 3.5 mg/kg:		Treatment 4.5 mg/kg:		Treatment 6 mg/kg	
		Group 1 (2-<7 y) N=14 n (%)	Group 2 (7-17 y) N=21 n (%)	Group 1 (2-<7 y) N=15 n (%)	Group 2 (7-17 y) N=16 n (%)	Group 1 (2-<7 y) N=20 n (%)	Group 2 (7-17 y) N=29 n (%)
Grade 0 >=LLN to <=ULN	Grade 1 >ULN to <=3x ULN	6 (43)	5 (24)	5 (33)	5 (31)	3 (15)	6 (21)
	Grade 2 >3x ULN to <=5x ULN	0	2 (10)	1 (7)	1 (6)	0	3 (10)
	Grade 3 >5x ULN to <=20x ULN	1 (7)	1 (5)	1 (7)	0	0	0
Grade 1 >ULN to <=3x ULN	Grade 2 >3x ULN to <=5x ULN	0	0	0	0	2 (10)	1 (3)
	Grade 3 >5x ULN to <=20x ULN	0	3 (14)	1 (7)	1 (6)	0	3 (10)
Grade 2 >3x ULN to <=5x ULN		0	1 (5)	1 (7)	1 (6)	0	0 (0)
	Subjects(filtered)	7 (50)	12 (57)	9 (60)	8 (50)	5 (25)	13 (45)
	1stCollItemSubjects	14 (100)	21 (100)	15 (100)	16 (100)	20 (100)	29 (100)

Source: Reviewer's analyses (JReview)

Table 11-11 Change from Baseline, AST

Baseline AST grade	Worst AST Grade Post baseline	Treatment 3.5 mg/kg:		Treatment 4.5 mg/kg:		Treatment 6 mg/kg	
		Group 1 (2-<7 y) N=14 n (%)	Group 2 (7-17 y) N=21 n (%)	Group 1 (2-<7 y) N=15 n (%)	Group 2 (7-17 y) N=16 n (%)	Group 1 (2-<7 y) N=20 n (%)	Group 2 (7-17 y) N=29 n (%)
Grade 0	Grade 1	3 (21)	8 (38)	7 (47)	3 (19)	3 (15)	9 (31)

>=LLN to <=ULN	>ULN to <=3x ULN						
	Grade 2 >3x ULN to <=5x ULN	1 (7)	2 (10)	1 (7)	1 (6.)	0 (0)	1 (3)
	Grade 3 >5x ULN to <=20x ULN	0 (0)	0 (0)	2 (13)	1 (6)	0 (0)	0 (0)
Grade 1 >ULN to <=3x ULN	Grade 2 >3x ULN to <=5x ULN	1 (7)	0 (0)	1 (7)	1 (6)	0 (0)	2 (7)
	Grade 3 >5x ULN to <=20x ULN	0 (0)	0 (0)	0 (0)	0 (0)	0 (0)	2 (7)
	Subjects(filtered)	5 (36)	10 (48)	11 (73)	6 (38)	3 (15)	14 (48)
	1stColltemSubjects	14 (100)	21 (100)	15 (100)	16 (100)	20 (100)	29 (100)

Source: Reviewer's analyses (JReview)

Total bilirubin: elevation postbaseline does not appear to be dose related.

Table 11-12 Change from Baseline, Total Bilirubin

Baseline Total Bilirubin - Grade Category	Worst Total Bilirubin - Grade Post baseline	Treatment 3.5 mg/kg:		Treatment 4.5 mg/kg:		Treatment 6 mg/kg		
		Group 1 (2-<7 y) N=14 n (%)	Group 2 (7-17 y) N=21 n (%)	Group 1 (2-<7 y) N=15 n (%)	Group 2 (7-17 y) N=16 n (%)	Group 1 (2-<7 y) N=20 n (%)	Group 2 (7-17 y) N=29 n (%)	
Base Grade 0 >=LLN to <=ULN	Grade 1 >ULN to <=1.5x ULN	2 (14)		1 (5)	2 (13)	5 (31)	3 (15)	1 (3)
	Grade 2 >1.5x ULN to <=3x ULN	2 (14)		2 (10)	1 (7)	3 (19)	0 (0.)	2 (7)
	Grade 3 >3x ULN to <=10x ULN	0 (0)		2 (10)	0 (0)	0 (0)	0 (0)	0 (0)
Base Grade 2 >ULN to <=1.5x ULN	Grade 2 >1.5x ULN to <=3x ULN	0 (0)		2 (10)	0 (0)	1 (6)	0 (0)	1 (3)
	Grade 3 >3x ULN to <=10x ULN	1 (7)		0 (0)	0 (0)	0 (0)	0 (0)	0 (0)
Base Grade 2: BILI >1.5x ULN to <=3x ULN		0 (0)		0 (0)	0 (0)	1 (6)	0 (0)	0 (0)
	Subjects(filtered)	5 (36)		7 (33)	3 (20)	10 (63)	3 (15)	4 (14)
	1stColltemSubjects	14 (100)		21 (100)	15 (100)	16 (100)	20 (100)	29 (100)

Source: Reviewer's analyses (JReview)

Electrolytes/Metabolism

Albumin: hypoalbuminemia is inversely correlated with increasing dose in older age group, but does not correlate with dose in younger age group.

Sodium: There were too few instances of hyponatremia 3/115 (3%) to determine dose dependency. Postbaseline increases in sodium were more prominent in 6 mg/kg dose group compared to 3.5mg/kg and 4.5 mg/kg groups (26% vs 13% and 11%, respectively).

Table 11-13 Change from Baseline, Hypernatremia

Baseline Hypernatremia Grade	Worst Hypernatremia Grade Post baseline	Treatment 3.5 mg/kg:		Treatment 4.5 mg/kg:		Treatment 6 mg/kg		
		Group 1 (2-<7 y) N=14 n (%)	Group 2 (7-17 y) N=21 n (%)	Group 1 (2-<7 y) N=15 n (%)	Group 2 (7-17 y) N=16 n (%)	Group 1 (2-<7 y) N=20 n (%)	Group 2 (7-17 y) N=29 n (%)	
base NA below LLN	Grade 0: NA Normal	0 (0)	0 (0)	0 (0)	0 (0)	0 (0)	2 (10)	4 (14)
	Grade 2: NA >150 to <=155 mmol/L	0 (0)	0 (0)	1 (7)	0 (0)	0 (0)	0 (0)	0 (0)
Base Grade 0: NA Normal	Grade 1: NA >ULN to <=150 mmol/L	1 (7)	3 (14)	1 (7)	2 (13)	0 (0)	5 (17)	
	Grade 2: NA >150 to <=155 mmol/L	0 (0)	0 (0)	0 (0)	0 (0)	1 (5)	1 (3)	
	Subjects(filtered)	1 (7)	3 (14)	2 (13)	2 (13)	3 (15)	10 (35)	
	1stColltemSubjects	14 (100)	21 (100)	15 (100)	16 (100)	20 (100)	29 (100)	

Source: Reviewer's analyses (JReview)

Potassium: Postbaseline hypokalemia appears to affect nearly all patients across all dose and age cohorts. Postbaseline worsening in hyperkalemia was observed less frequently and did not appear to be age or dose-dependent.

Table 11-14 Change from Baseline, Hypokalemia

Baseline Hypokalemia Grade	Worst Hypokalemia Grade Post baseline	Treatment 3.5 mg/kg:		Treatment 4.5 mg/kg:		Treatment 6 mg/kg	
		Group 1 (2-<7 y) N=14 n (%)	Group 2 (7-17 y) N=21 n (%)	Group 1 (2-<7 y) N=15 n (%)	Group 2 (7-17 y) N=16 n (%)	Group 1 (2-<7 y) N=20 n (%)	Group 2 (7-17 y) N=29 n (%)
base potassium below ULN	Grade 0: >=LLN - <=ULN	0 (0)	0 (0)	1 (7)	0 (0)	0 (0)	0 (0)
	Grade 3: <3.0-2.5 mmol/L	1 (7)	0 (0)	0 (0)	0 (0)	0 (0)	0 (0)
Base Grade 0: >=LLN - <=ULN	base potassium above ULN	0 (0)	1 (5)	0 (0)	0 (0)	0 (0)	0 (0)
	Grade 3: <3.0-2.5 mmol/L	3 (21)	3 (14)	0 (0)	4 (25)	1 (5)	2 (7)

Baseline Hypokalemia Grade	Worst Hypokalemia Grade Post baseline	Treatment 3.5 mg/kg:		Treatment 4.5 mg/kg:		Treatment 6 mg/kg	
		Group 1 (2-<7 y) N=14 n (%)	Group 2 (7-17 y) N=21 n (%)	Group 1 (2-<7 y) N=15 n (%)	Group 2 (7-17 y) N=16 n (%)	Group 1 (2-<7 y) N=20 n (%)	Group 2 (7-17 y) N=29 n (%)
	Grade 4: <2.5 mmol/L	0 (0)	0 (0)	0 (0)	0 (0)	2 (10)	1 (3)
Base Grade 2: <LLN - 3.0 mmol/L	Grade 3: <3.0-2.5 mmol/L	0 (0)	0 (0)	0 (0)	0 (0)	1 (5)	0 (0)
	Grade 4: <2.5 mmol/L	0 (0)	0 (0)	0 (0)	0 (0)	0 (0)	0 (0)
	Subjects(filtered)	14 (100)	19 (91)	12 (80)	16 (100)	19 (95)	25 (86)
	Total Subjects	14 (100)	21 (100)	15 (100)	16 (100)	20 (100)	29 (100)

Source: Reviewer's analyses (JReview)

Table 11-15 Changes from Baseline, Hyperkalemia

Baseline Hypokalemia Grade	Worst Hyperkalemia Grade Post baseline	Treatment 3.5 mg/kg:		Treatment 4.5 mg/kg:		Treatment 6 mg/kg	
		Group 1 (2-<7 y) N=14 n (%)	Group 2 (7-17 y) N=21 n (%)	Group 1 (2-<7 y) N=15 n (%)	Group 2 (7-17 y) N=16 n (%)	Group 1 (2-<7 y) N=20 n (%)	Group 2 (7-17 y) N=29 n (%)
low: below LLN	Grade 1: >ULN-5.5 mmol/L	0 (0)	1 (5)	1 (7)	0 (0)	1 (5)	1 (3)
	Grade 2: >5.5-6.0 mmol/L	0 (0)	0 (0)	1 (7)	0 (0)	0 (0)	0 (0)
Grade 0	Grade 1: >ULN-5.5 mmol/L	4 (29)	4 (19)	6 (40)	2 (13)	4 (20)	10 (34)
	Grade 2: >5.5-6.0 mmol/L	1 (7)	1 (5)	0 (0)	2 (13)	2 (10)	0 (0)
	Grade 3: >6.0-7.0 mmol/L	0 (0)	1 (5)	0 (0)	1 (6)	1 (5)	0 (0)
	Grade 4: >7 mmol/L Life Threatening	1 (7)	0 (0)	0 (0)	0 (0)	0 (0)	0 (0)
	Subjects(filtered)	6 (43)	6 (29)	8 (53)	4 (25)	7 (35)	11 (38)
	Total Subjects	14 (100)	21 (100)	15 (100)	16 (100)	20 (100)	29 (100)

Source: Reviewer's analyses (JReview)

Magnesium: Few patients experienced postbaseline hyper or hypomagnesemia; no trends in postbaseline elevation or decrease in magnesium levels related to dose have been identified.

NDA Multi-disciplinary Review and Evaluation, sNDA 205596, 205053, 214770
 NOXAFIL® (posaconazole) injection, delayed release tablet, PowderMix
 For prophylaxis of invasive fungal infections in pediatric patients 2 years of age and older
 For treatment of invasive aspergillosis in adults and pediatric patients 13 years and older

Table 11-16 Change from Baseline, Hypomagnesemia

Baseline Hypokalemia Grade	Worst Hypomagnesemia Grade Post baseline	Treatment 3.5 mg/kg:		Treatment 4.5 mg/kg:		Treatment 6 mg/kg	
		Group 1 (2-<7 y) N=14 n (%)	Group 2 (7-17 y) N=21 n (%)	Group 1 (2-<7 y) N=15 n (%)	Group 2 (7-17 y) N=16 n (%)	Group 1 (2-<7 y) N=20 n (%)	Group 2 (7-17 y) N=29 n (%)
Base Grade 0: Magnesium >=LLN to <=ULN	Grade 2: Hypomagnesemia <.5 to .4 mmol/L	1 (7)	1 (5)	1 (7)		1 (5)	2 (7)
	Subjects(filtered)	1 (7)	1 (5)	1 (7)		1 (5)	2 (7)
	Total Subjects	14 (100)	21 (100)	15 (100)		20 (100)	29 (100)

Source: Reviewer's analyses (JReview)

Table 11-17 Change from Baseline, Hypermagnesemia

Baseline Hypokalemia Grade	Worst Hypermagnesemia Grade Post baseline	Treatment 3.5 mg/kg:		Treatment 4.5 mg/kg:		Treatment 6 mg/kg	
		Group 1 (2-<7 y) N=14 n (%)	Group 2 (7-17 y) N=21 n (%)	Group 1 (2-<7 y) N=15 n (%)	Group 2 (7-17 y) N=16 n (%)	Group 1 (2-<7 y) N=20 n (%)	Group 2 (7-17 y) N=29 n (%)
base MG below LLN	Grade 0: Magnesium Normal		0	1 (7)	1 (6)	0	2 (7)
	Grade 1: HyperMG >ULN to <=1.23 mmol/L		0	0	0	1 (5)	0
	Grade 3: HyperMG >1.23 to <=3.3 mmol/L		0	0	0	1 (5)	0
Base Grade 0: Magnesium Normal	Grade 1: HyperMG >ULN to <=1.23 mmol/L		3 (14)	2 (13)	4 (25)	3 (15)	4 (14)
	Grade 4: HyperMG >3.3 mmol/L		0	0	0	1 (5)	0
	Subjects(filtered)		3 (14)	3 (20)	5 (31)	4 (20)	6 (21)

Source: Reviewer's analyses (JReview)Source: Reviewer's analyses (JReview)

Creatinine: Patients in 6 mg/kg dose cohort appear to have experienced worsening renal function on par with patients in 3.5 mg/kg dose cohort (18% each) as compared to only 6% of patients in 4.5 mg/kg dose group.

Table 11-18 Change from Baseline, Creatinine

Baseline Creatinine Grade	Worst Creatinine Grade Post baseline	Treatment 3.5 mg/kg:		Treatment 4.5 mg/kg:		Treatment 6 mg/kg	
		Group 1 (2-<7 y) N=14 n (%)	Group 2 (7-17 y) N=21 n (%)	Group 1 (2-<7 y) N=15 n (%)	Group 2 (7-17 y) N=16 n (%)	Group 1 (2-<7 y) N=20 n (%)	Group 2 (7-17 y) N=29 n (%)
base below lower limit	Grade 0: Normal	0 (0)	1 (5)	0 (0)	0 (0)	0 (0)	0 (0).
	Grade 1: >ULN to 1.5 x ULN	0 (0)	1 (5)	0 (0)	0 (0)	1 (5)	1 (3)
	Grade 2: >1.5 to 3 x ULN	0 (0)	0 (0)	0 (0)	0 (0).	0 (0)	1 (3)

NDA Multi-disciplinary Review and Evaluation, sNDA 205596, 205053, 214770
 NOXAFIL® (posaconazole) injection, delayed release tablet, PowderMix
 For prophylaxis of invasive fungal infections in pediatric patients 2 years of age and older
 For treatment of invasive aspergillosis in adults and pediatric patients 13 years and older

Baseline Creatinine Grade	Worst Creatinine Grade Post baseline	Treatment 3.5 mg/kg:		Treatment 4.5 mg/kg:		Treatment 6 mg/kg	
		Group 1 (2-<7 y) N=14 n (%)	Group 2 (7-17 y) N=21 n (%)	Group 1 (2-<7 y) N=15 n (%)	Group 2 (7-17 y) N=16 n (%)	Group 1 (2-<7 y) N=20 n (%)	Group 2 (7-17 y) N=29 n (%)
	Grade 3: >3 to 6 x ULN	0 (0)	0 (0)	0 (0)	0 (0)	0 (0)	1 (3)
Grade 0: Normal	Grade 1: >ULN to 1.5 x ULN	1 (7)	1 (5)	1 (7)	0 (0)	3 (15)	2 (7)
	Grade 2: >1.5 to 3 x ULN	1 (7)	1 (5)	0 (0)	1 (6)	0 (0)	0 (0)
	Subjects(filtered)	2 (14)	4 (19)	1 (7)	1 (6)	4 (20)	5 (17)
	1stCollItemSubjects	14 (100)	21 (100)	15 (100)	16 (100)	20 (100)	29 (100)

Source: Reviewer's analyses (JReview)

Hemoglobin: Nearly all patients on the study have experienced postbaseline worsening of anemia; however, no pattern that could have suggested a dose response in postbaseline anemia was identified.

Table 11-19 Change from Baseline, Hemoglobin

Baseline Anemia (Hb) Grade	Worst Anemia (Hb) Grade Post baseline	Treatment 3.5 mg/kg:		Treatment 4.5 mg/kg:		Treatment 6 mg/kg	
		Group 1 (2-<7 y) N=14 n (%)	Group 2 (7-17 y) N=21 n (%)	Group 1 (2-<7 y) N=15 n (%)	Group 2 (7-17 y) N=16 n (%)	Group 1 (2-<7 y) N=20 n (%)	Group 2 (7-17 y) N=29 n (%)
Base Grade 0: Hgb >=LLN to <=ULN	Grade 1: Hgb <LLN - 100 g/L	0 (0)	1 (5)	0 (0)	0 (0)	0 (0)	1 (3)
	Grade 2: Hgb <100 - 80g/L	0 (0)	1 (5)	0 (0)	0 (0)	1 (5)	0 (0)
	Grade 3: Hgb <80 g/L	0 (0)	1 (5)	1 (7)	1 (6)	1 (5)	2 (7)
Base Grade 1: Hgb <LLN - 100 g/L	Grade 2: Hgb <100 - 80g/L	2 (14)	3 (14)	1 (7)	1 (6)	3 (15)	3 (10)
	Grade 3: Hgb <80 g/L	2 (14)	2 (10)	1 (7)	0 (0)	0 (0)	0 (0)
Base Grade 2: Hgb <100 - 80g/L	Grade 3: Hgb <80 g/L	5 (36)	3 (14)	4 (27)	6 (36)	7 (35)	13 (45)
	Subjects(filtered)	14 (100)	20 (95)	15 (100)	16 (100)	20 (100)	28 (97)
	1stCollItemSubjects	14 (100)	21 (100)	15 (100)	16 (100)	20 (100)	29 (100)

Source: Reviewer's analyses (JReview)

Platelets: The majority of the patients in the study experienced thrombocytopenia. A slightly greater proportion of patients in the 6 mg/kg group experienced worsening of their thrombocytopenia compared to the 3.5 and 4.5 mg/kg dose cohorts [45 (92%) vs. 28(80%) vs. 28 (90%)], respectively.

Table 11-20 Change from Baseline, Thrombocytopenia

Baseline Thrombocytopenia Grade	Worst Thrombocytopenia Grade Post baseline	Treatment 3.5 mg/kg:		Treatment 4.5 mg/kg:		Treatment 6 mg/kg	
		Group 1 (2-<7 y) N=14 n (%)	Group 2 (7-17 y) N=21 n (%)	Group 1 (2-<7 y) N=15 n (%)	Group 2 (7-17 y) N=16 n (%)	Group 1 (2-<7 y) N=20 n (%)	Group 2 (7-17 y) N=29 n (%)
Base Grade 0: Platelets Normal	Grade 2: Platelets <75 to >=50 10e9 /L	0 (0)	0 (0)	0 (0)	0 (0)	1 (5)	0 (0)
	Grade 3: Platelets <50 to >=25 10e9 /L	1 (7)	0 (0)	0 (0)	0 (0)	0 (0)	0 (0)
	Grade 4: Platelets <25 10e9 /L	2 (14)	3 (14)	0 (0)	3 (19)	1 (5)	1 (3)
Base Grade 1: Platelets <LLN to >=75 10e9 /L	Grade 3: Platelets <50 to >=25 10e9 /L	1 (7)	0 (0)	0 (0)	0 (0)	1 (5)	2 (7)
	Grade 4: Platelets <25 10e9 /L	3 (21)	4 (19)	4 (27)	1 (6)	6 (30)	2 (7)
Base Grade 2: Platelets <75 to >=50 10e9 /L	Grade 3: Platelets <50 to >=25 10e9 /L	0 (0)	0 (0)	0 (0)	0 (0)	2 (10)	0 (0)
	Grade 4: Platelets <25 10e9 /L	2 (14)	3 (14)	3 (20)	2 (13)	1 (5)	6 (21)
	Subjects(filtered)	10 (71)	18 (86)	12 (80)	16 (100)	20 (100)	25 (86)
	1stCollItemSubjects	14 (100)	21 (100)	15 (100)	16 (100)	20 (100)	29 (100)

Source: Reviewer's analyses (JReview)

WBC/ANC: not patterns suggestive of dose related shifts in decreases in WBC/ANC were identified.

Vital Signs

There were no clinically meaningful changes in vital sign measurements or physical examinations.

The largest increase in mean systolic blood pressure from baseline was 13 mmHg on Day 28 in the 3.5 mg/kg cohort, 5 mmHg on Day 3 in the 4.5 mg/kg cohort, and 23 mmHg on Day 27 for the 6mg/kg cohort with a median, mean, and range of systolic blood pressure measurements of 104, 104, and 79-138 mm Hg, respectively.

Electrocardiograms (ECGs)

QT

No clinically significant ECG changes suggestive of a dose-related QTc interval prolongation were identified.

Adverse Events of Special Interest

AEs of special interest included azole class effects and those reported in adult trials: dermatologic, CNS/psychiatric, ocular, hepatic, and adrenal disorders, and QT prolongation.

NDA Multi-disciplinary Review and Evaluation, sNDA 205596, 205053, 214770
NOXAFIL® (posaconazole) injection, delayed release tablet, PowderMix
For prophylaxis of invasive fungal infections in pediatric patients 2 years of age and older
For treatment of invasive aspergillosis in adults and pediatric patients 13 years and older

The most common adverse events of special interest reported consistently in the pediatric and adult patients included mucocutaneous adverse events, elevated LFTs, and hypokalemia.

11.1. P032: A Study of the Safety, Tolerance, and Pharmacokinetics of Oral Posaconazole (POS) in Immunocompromised Pediatric Subjects with Neutropenia

Refer to the clinical review for POS oral suspension, injection and delayed release tablet NDAs for the prophylaxis of invasive *Aspergillus* and *Candida* infections in patients 13 years of age and older. POS oral suspension was approved on 09/15/2006, and POS delayed release tablets and IV injection formulations were approved on 11/25/2013 and 03/13/2014, respectively.

11.2. Postmarketing Safety of Posaconazole in Pediatric Patients

Since 2005, there have been several post-marketing reports (>1400 from observational studies in published literature and 465 in the Applicant's global safety database) regarding the use of posaconazole for prophylaxis and treatment of IFI in pediatric patients younger than 18 years generally demonstrating a safety profile similar to that of adults.

12 Labeling Recommendations

12.1. Prescription Drug Labeling

The following updates were made to the Noxafil Prescribing information

- Section 1 Indications and Usage
 - Expand indication of IFI prophylaxis to pediatric patients 2 years of age and older
 - Add a new indication of treatment of invasive aspergillosis in adults and pediatric patients 13 years of age and older
- Section 2, Dosage and Administration
 - Administration with alcohol recommendation
 - Pediatric dose regimen for IV Injection, PowderMix for delayed release oral suspension, delayed release tablet
 - Treatment of invasive aspergillosis regimen
- Section 4: Contraindications
 - Noxafil PowderMix in patients with hereditary fructose intolerance
- Section 5 Warnings and Precautions
 - Noxafil PowderMix in pediatric patients (to obtain careful history on sucrose/fructose tolerance)
- Section 6, Adverse Reactions
 - Clinical trials experience in pediatric patients and in patients with invasive aspergillosis
- Section 7, Drug Interactions
 - Administration with alcohol
- Section 8.4 Pediatric Use information
- Section 11 Product Information included the description of the new formulation Noxafil PowderMix for delayed release oral suspension
- Section 12.3, Pharmacokinetics
 - POWDERMIX PK
 - Specific populations
- Section 13.2 Updated information on nonclinical safety studies in dogs for Noxafil Injection
- Section 14 Clinical Trials included information on the results of Trial 069 for the treatment of invasive aspergillosis
- Section 16 How Supplied included information on the new formulation Noxafil PowderMix for delayed release oral suspension
- Section 17 Patient Counseling Information: to include information regarding hereditary fructose intolerance awareness when Noxafil PowderMix is to be prescribed

NDA Multi-disciplinary Review and Evaluation, sNDA 205596, 205053, 214770
NOXAFIL® (posaconazole) injection, delayed release tablet, PowderMix
For prophylaxis of invasive fungal infections in pediatric patients 2 years of age and older
For treatment of invasive aspergillosis in adults and pediatric patients 13 years and older

12.2. **Other Prescription Drug Labeling**

- Instructions for Use Booklet
- Patient Information

NDA Multi-disciplinary Review and Evaluation, sNDA 205596, 205053, 214770
NOXAFIL® (posaconazole) injection, delayed release tablet, PowderMix
For prophylaxis of invasive fungal infections in pediatric patients 2 years of age and older
For treatment of invasive aspergillosis in adults and pediatric patients 13 years and older

13 Risk Evaluation and Mitigation Strategies (REMS)

No REMS were considered necessary for these applications.

NDA Multi-disciplinary Review and Evaluation, sNDA 205596, 205053, 214770
NOXAFIL® (posaconazole) injection, delayed release tablet, PowderMix
For prophylaxis of invasive fungal infections in pediatric patients 2 years of age and older
For treatment of invasive aspergillosis in adults and pediatric patients 13 years and older

14 Postmarketing Requirements and Commitment

Postmarketing commitments

Develop a new dissolution method using constituted suspension samples for the Quality Control (QC) testing of the proposed drug product. Submit a method validation report and include additional dissolution data for constituted suspension samples from unexpired batches using 65 rpm and 75 rpm to determine an appropriate paddle rotation speed.

Final Report Submission: 08/2021

The above changes in the dissolution method resulting from this PMC study should be submitted to the NDA as a prior-approval supplement before marketing any commercial drug product batches.

The Agency also reached an agreement with the Applicant on an the following PMC to develop an appropriate administration method for Noxafil PowderMix (posaconazole) to support dosing in pediatric patients who weigh greater than 40 kg.

Provide evidence that the design of the user interface supports dosing and administration of Noxafil PowderMix to patients who weigh greater than 40 kg and data to demonstrate that the entire dose can be delivered to these patients using the proposed method of administration.

Draft Protocol Submission,: 06/2021
Final Protocol Submission: 07/2021
Final Report Submission: 08/2021

If based on the results of above PMC, a human factors (HF) validation study is necessary to support the new administration method, conduct the HF study according to the following timelines:

Draft Protocol Submission: 11/2021
Final Protocol Submission: 02/2022
Study/Trial Completion: 05/2022
Final Report Submission: 06/2022

15 Appendices

15.1. Financial Disclosure

Study MK5592-069

Financial disclosure documentation was obtained from all Principal and Sub-Investigators involved in the trial, except for two sub-Investigators:

Dr. Herman Schneider from site 0188 in Chile (the site randomized three subjects) and Dr. Tingting Liu from site 0263 in China (the site randomized five subjects). These two sub-investigators did not return forms with the requested information and the Applicant performed due diligence by following up with two requests for the information to each sub-investigator.

The spouse of [REDACTED] (b) (6) works for Merck; [REDACTED] (b) (6)

Clinical Investigators/Sub-Investigators Who Hold Financial Interests and/or Arrangements Requiring Disclosure:

The Applicant stated that medical institutions where two sub-investigators are employed received grants for research that was not related to study MK-5592-069.

(b) (6)

Covered Clinical Study (Name and/or Number): MK5592-P069

Was a list of clinical investigators provided:	Yes <input checked="" type="checkbox"/>	No <input type="checkbox"/> (Request list from Applicant)
Total number of investigators identified: <u>555</u>		
Number of investigators who are Sponsor employees (including both full-time and part-time employees): <u>0</u>		
Number of investigators with disclosable financial interests/arrangements (Form FDA 3455): <u>2</u>		
If there are investigators with disclosable financial interests/arrangements, identify the number of investigators with interests/arrangements in each category (as defined in 21 CFR		

NDA Multi-disciplinary Review and Evaluation, sNDA 205596, 205053, 214770
 NOXAFIL® (posaconazole) injection, delayed release tablet, PowderMix
 For prophylaxis of invasive fungal infections in pediatric patients 2 years of age and older
 For treatment of invasive aspergillosis in adults and pediatric patients 13 years and older

54.2(a), (b), (c) and (f):		
Compensation to the investigator for conducting the study where the value could be influenced by the outcome of the study: <u>0</u>		
Significant payments of other sorts: <u>2</u>		
Proprietary interest in the product tested held by investigator: <u>0</u>		
Significant equity interest held by investigator in Sponsor of covered study: <u>0</u>		
Is an attachment provided with details of the disclosable financial interests/arrangements:	Yes <input checked="" type="checkbox"/>	No <input type="checkbox"/> (Request details from Applicant)
Is a description of the steps taken to minimize potential bias provided:	Yes <input checked="" type="checkbox"/>	No <input type="checkbox"/> (Request information from Applicant)
Number of investigators with certification of due diligence (Form FDA 3454, box 3): <u>555</u>		
Is an attachment provided with the reason:	Yes <input checked="" type="checkbox"/>	No <input type="checkbox"/> (Request explanation from Applicant)

Financial Disclosure information for Study P097

Was a list of clinical investigators provided:	Yes <input checked="" type="checkbox"/>	No <input type="checkbox"/> (Request list from Applicant)
Total number of investigators identified: <u>123</u>		
Number of investigators who are Sponsor employees (including both full-time and part-time employees): <u>0</u>		
Number of investigators with disclosable financial interests/arrangements (Form FDA 3455): <u>0</u>		
If there are investigators with disclosable financial interests/arrangements, identify the number of investigators with interests/arrangements in each category (as defined in 21 CFR 54.2(a), (b), (c) and (f)):		
Compensation to the investigator for conducting the study where the value could be influenced by the outcome of the study: <u>N/A</u>		
Significant payments of other sorts: <u>N/A</u>		
Proprietary interest in the product tested held by investigator: <u>N/A</u>		

NDA Multi-disciplinary Review and Evaluation, sNDA 205596, 205053, 214770
 NOXAFIL® (posaconazole) injection, delayed release tablet, PowderMix
 For prophylaxis of invasive fungal infections in pediatric patients 2 years of age and older
 For treatment of invasive aspergillosis in adults and pediatric patients 13 years and older

Significant equity interest held by investigator in S		
Sponsor of covered study: <u>N/A</u>		
Is an attachment provided with details of the disclosable financial interests/arrangements:	Yes <input checked="" type="checkbox"/>	No <input type="checkbox"/> (Request details from Applicant)
Is a description of the steps taken to minimize potential bias provided:	Yes <input checked="" type="checkbox"/>	No <input type="checkbox"/> (Request information from Applicant)
Number of investigators with certification of due diligence (Form FDA 3454, box 3) <u>123</u>		
Is an attachment provided with the reason:	Yes <input checked="" type="checkbox"/>	No <input type="checkbox"/> (Request explanation from Applicant)

15.2. OCP Appendices (Technical documents supporting OCP recommendations)

15.2.1. Individual Study Reviews

15.2.2. *Study P106: Relative Bioavailability and Food-Effect Study*

This study was a crossover-design, three-period, relative bioavailability study comparing the approved Noxafil delayed-release tablet (DRT) under the fasted condition to a Noxafil prototype powder for delayed-release oral suspension (pPOWDERMIX) under both fasted and fed conditions in 13 healthy volunteers. Each healthy volunteer received 100 mg of posaconazole in each period, which is the highest available dose strength of the DRT. The effect of food on posaconazole pPOWDERMIX PK was evaluated using a high-fat meal, per the FDA food-effect guidance. There was a 10-day washout between each period.

The PK results of Study P106 are shown in Table 15-1. Relative Bioavailability of 100 mg Posaconazole Administered to 13 Healthy Volunteers as pPOWDERMIX Fasted, pPOWDERMIX Fed, or DRT Fasted. The posaconazole pPOWDERMIX has a 17% higher C_{max} and 19% higher AUC_{0-72} relative to the posaconazole DRT with both formulations under fasted conditions. Administration of a high-fat meal with the posaconazole pPOWDERMIX decreases the posaconazole C_{max} by 33% and the AUC_{0-72} by 6%. The decrease in AUC_{0-72} when the pPOWDERMIX is administered with a high-fat meal is not considered clinically or statistically significant. The reduction in the C_{max} of the pPOWDERMIX under fed conditions is likely the result of the substantially prolonged T_{max} ; as seen in Table 0-1, median and range T_{max} are doubled under fed conditions. Because steady-state average concentration was previously identified as the relevant PK index in the exposure-response relationship for efficacy, the changes in T_{max} and C_{max} under fed conditions are not expected to have a clinically significant effect.

Table 15-1. Relative Bioavailability of 100 mg Posaconazole Administered to 13 Healthy Volunteers as pPOWDERMIX Fasted, pPOWDERMIX Fed, or DRT Fasted

Treatment	GM (95% CI)		
	C_{max} * (ng/mL)	AUC_{0-72} * (hr·ng/mL)	T_{max} ** (hr)
pPOWDERMIX Fasted	371 (312, 441)	9957 (8160, 12149)	4.00 (3.00, 12.00)
pPOWDERMIX Fed	251 (211, 298)	9367 (7677, 11431)	8.00 (6.00, 24.00)
DRT Fasted	316 (266, 376)	8389 (6874, 10237)	5.00 (4.00, 6.00)
Comparison	GMR [90% CI]		
	C_{max} (ng/mL)	AUC_{0-72} (hr·ng/mL)	
Fasted pPOWDERMIX vs Fasted DRT	1.17 [1.04, 1.33]	1.19 [1.10, 1.28]	
Fed pPOWDERMIX vs Fasted pPOWDERMIX	0.67 [0.59, 0.77]	0.94 [0.87, 1.02]	

NDA Multi-disciplinary Review and Evaluation, sNDA 205596, 205053, 214770
NOXAFIL® (posaconazole) injection, delayed release tablet, PowderMix
For prophylaxis of invasive fungal infections in pediatric patients 2 years of age and older
For treatment of invasive aspergillosis in adults and pediatric patients 13 years and older

Source: Adapted from the Applicant's Clinical Study Report

*: Back-transformed least squares mean and confidence interval from mixed effects model performed on natural log-transformed values.

**: Median (Minimum, Maximum).

Abbreviations: AUC₀₋₇₂, area under the plasma concentration-time curve from 0 to 72 hours; CI, Confidence interval; C_{max}, maximum observed plasma concentration; DRT, delayed-release tablet; GM, Geometric least-squares mean; GMR = Geometric least-squares mean ratio between treatments; pPOWDERMIX, prototype powder for delayed-release oral suspension

15.2.3. Study P097: Phase 1B Safety and PK Study in Pediatric Patients with Neutropenia

This study was a nonrandomized, open-label, multicenter, Phase 1b study to assess the safety, tolerability, and PK of three dose regimens of posaconazole administered as an IV infusion and as a powder for delayed-release oral suspension (POWDERMIX) to pediatric patients with neutropenia. A total of 115 pediatric patients 2-17 years of age were enrolled and allocated to the 3.5 mg/kg, 4.5 mg/kg, or 6 mg/kg posaconazole dose cohorts. In each dose cohort, posaconazole was administered as an IV solution BID on Day 1 and then QD starting on Day 2. After 10 days, the patient could be switched to QD administration of the POWDERMIX formulation without regards for meal administration if the patient could tolerate oral administration. Serial PK samples were collected both in the IV and POWDERMIX treatment periods to assess whether each dose regimen would achieve the PK target: steady-state average concentration (C_{avg}) between 500 and 2500 ng/mL.

A summary of PK results is shown in Table 15-2. Summary of Plasma Steady-State Pharmacokinetic Parameters of Posaconazole After Administration of the Posaconazole IV and Oral Formulations. AUC and C_{max} of posaconazole appeared to increase in a roughly dose-proportional manner between 3.5 mg/kg and 6 mg/kg in pediatric patients. Posaconazole AUC and C_{max} were higher in the IV period than the POWDERMIX period, which indicates that the POWDERMIX has a lower bioavailability than the IV formulation. Posaconazole AUC was higher in pediatric patients 7 to 17 years than pediatric patients 2 to <7 years for each dose cohort and formulation, which aligns with the expectation that younger pediatric patients will have a higher weight-normalized clearance.

Table 15-2. Summary of Plasma Steady-State Pharmacokinetic Parameters of Posaconazole After Administration of the Posaconazole IV and Oral Formulations

Dose Cohort	Age (yr)	Formulation	N	C_{max} (ng/mL)*	T_{max} (hr)**	AUC ₀₋₂₄ (hr*ng/mL)*
3.5 mg/kg	2 to <7	IV	11	1590 (43.1)	1.78 (1.67 – 5.53)	17800 (55.0)
		POWDERMIX	5	884 (44.4)	3.83 (1.92 – 4.25)	12200 (36.0)
	7 to 17	IV	19	2450 (72.7)	1.77 (0.00 – 3.50)	27300 (49.7)
		POWDERMIX	10	1340 (30.8)	2.20 (1.92 – 6.03)	20700 (33.8)
4.5 mg/kg	2 to <7	IV	14	2320 (39.8)	1.78 (1.42 – 5.90)	25600 (30.0)
		POWDERMIX	8	1550 (40.8)	3.82 (1.88 – 5.92)	21600 (64.5)
	7 to 17	IV	15	2310 (40.3)	1.75 (1.52 – 1.80)	29800 (42.9)
		POWDERMIX	8	1670 (28.5)	6.14 (1.98 – 7.98)	28700 (33.7)
6.0 mg/kg	2 to <7	IV	17	3060 (54.1)	1.75 (1.57 – 1.83)	31100 (48.9)
		POWDERMIX	7	1510 (43.4)	4.00 (2.17 – 7.92)	23000 (47.3)
	7 to 17	IV	24	3340 (39.4)	1.77 (1.33 – 6.00)	44200 (41.5)
		POWDERMIX	12	1370 (178.5)	2.78 (0.00 – 4.00)	25000 (184.3)

Source: Adapted from the Applicant's Clinical Study Report

*: Geometric mean (Coefficient of Variation %)

** : Median (Minimum, Maximum).

Abbreviations: AUC₀₋₂₄, area under the plasma concentration-time curve from 0 to 24 hours; C_{max} , maximum observed plasma concentration; IV, Intravenous; N, number; POWDERMIX, powder for delayed-release oral suspension

NDA Multi-disciplinary Review and Evaluation, sNDA 205596, 205053, 214770
 NOXAFIL® (posaconazole) injection, delayed release tablet, PowderMix
 For prophylaxis of invasive fungal infections in pediatric patients 2 years of age and older
 For treatment of invasive aspergillosis in adults and pediatric patients 13 years and older

PK results regarding C_{avg} are shown in Table 15-3. Most patients in the 4.5 mg/kg and 6 mg/kg dose cohort achieved the PK target, 90% of patients with C_{avg} between 500 and 2500 ng/mL during both the IV and POWDERMIX periods. However, there was a trend toward more patients in the 6 mg/kg cohort having C_{avg} greater than 2500 ng/mL relative to the 4.5 mg/kg cohort. The population PK analysis will help to further clarify the appropriate posaconazole dose regimen.

Table 15-3. Summary of Posaconazole Steady-State Average Concentration and PK Target Attainment in Patients After Administration of the Posaconazole IV and Oral Formulations

Dose Cohort	Age (yr)	Formulation	N	Value**	C_{avg} (ng/mL)*		
					<500	500-2500	>2500
3.5 mg/kg	2 to <7	IV	11	743 (55.0)	2 (18%)	9 (82%)	0
		POWDERMIX	5	510 (36.0)	3 (60%)	2 (40%)	0
	7 to 17	IV	19	1140 (49.7)	0	18 (95%)	1 (5%)
		POWDERMIX	10	861 (33.8)	1 (10%)	9 (90%)	0
4.5 mg/kg	2 to <7	IV	14	1070 (30.0)	0	14 (100%)	0
		POWDERMIX	8	901 (64.5)	1 (13%)	7 (88%)	0
	7 to 17	IV	15	1240 (42.9)	0	14 (93%)	1 (7%)
		POWDERMIX	8	1200 (33.7)	0	8 (100%)	0
6.0 mg/kg	2 to <7	IV	17	1300 (48.9)	0	15 (88%)	2 (12%)
		POWDERMIX	7	960 (47.3)	0	7 (100%)	0
	7 to 17	IV	24	1840 (41.5)	0	18 (75%)	6 (25%)
		POWDERMIX	12	1040 (184.3)	2 (17%)	8 (67%)	2 (17%)

Source: Adapted from the Applicant's Clinical Study Report

*: Percent of patients with steady-state C_{avg} in each category

** : Geometric mean (Coefficient of Variation %)

Abbreviations: C_{avg} , average plasma concentration; IV, Intravenous; N, number; POWDERMIX, powder for delayed-release oral suspension

Posaconazole was well-tolerated in patients. Four out of 115 enrolled patients died. There was no apparent relationship between survival and posaconazole dose regimen.

NDA Multi-disciplinary Review and Evaluation, sNDA 205596, 205053, 214770
 NOXAFIL® (posaconazole) injection, delayed release tablet, PowderMix
 For prophylaxis of invasive fungal infections in pediatric patients 2 years of age and older
 For treatment of invasive aspergillosis in adults and pediatric patients 13 years and older

15.2.4. Pharmacometrics Review

15.2.5. *Results of Applicant's Analysis*

Prophylaxis of Invasive *Aspergillus* and *Candida* Infections (IFI) in Pediatric Patients

The Applicant submitted Modeling and Simulation Report 059DG to provide a population PK (PPK) analysis of the posaconazole (POS) concentration data from for Study P097 (b) (4)

This study included pediatric patients between 2 and 17 years of age administered POS as intravenous injection (IVI) and powder for delayed-release oral suspension (POWDERMIX) between doses of 3.5 mg/kg and 6 mg/kg as shown in Table 15-4. **Study Included in Applicant's POS PPK Report (IFI)..**

Table 15-4. Study Included in Applicant's POS PPK Report (IFI).

Study (Phase)	Title	Number of subjects	Population	Dosing regimen	PK measurements				
P097	A Study of the Safety, Tolerability, and Pharmacokinetics of Intravenous (IV) and Powder for Oral Suspension Formulations of Posaconazole (POS) in Immunocompromised Pediatric Subjects with Neutropenia	114	Male/Female immunocompromised subjects who have documented or anticipated neutropenia Age 2 – 17 years	<table border="0"> <tr> <td><u>Cohort 1</u> 3.5 mg/kg</td> <td rowspan="3">Day 1 – IV BID Day 2 to 10^a – IV QD Days 10 to 28 – Oral PFS QD</td> </tr> <tr> <td><u>Cohort 2</u> 4.5 mg/kg</td> </tr> <tr> <td><u>Cohort 3</u> 6 mg/kg</td> </tr> </table>	<u>Cohort 1</u> 3.5 mg/kg	Day 1 – IV BID Day 2 to 10 ^a – IV QD Days 10 to 28 – Oral PFS QD	<u>Cohort 2</u> 4.5 mg/kg	<u>Cohort 3</u> 6 mg/kg	<u>IV administration:</u> Day 6 – Predose <u>Day 7, 8, 9 or 10</u> – pre-dose, within 15 min after end of infusion, and at 4, 6, 12 and 24 h post start of infusion <u>Oral PFS administration:</u> Day 6 – Predose <u>Day 7, 8, 9 or 10</u> – pre-dose, within 15 min after end of infusion, and at 4, 6, 12 and 24 h post-dose
<u>Cohort 1</u> 3.5 mg/kg	Day 1 – IV BID Day 2 to 10 ^a – IV QD Days 10 to 28 – Oral PFS QD								
<u>Cohort 2</u> 4.5 mg/kg									
<u>Cohort 3</u> 6 mg/kg									

^a Switch to IV could also occur at later Day

Source: Applicant PPK Report (IFI)

The Applicant modeled POS PK using a one-compartment model structure with log-transformed values of POS concentration and first-order absorption for the POS POWDERMIX. Bodyweight-based allometric scaling was used for the covariate relationships for clearance (CL) and volume of distribution (V), with the exponents estimated in the modeling. Inter-individual variability terms were included for CL, V, and bioavailability (F) with the F term described in a logit function to constrain the F between 0 and 1. Parameter estimates of the Applicant's final PPK model are shown in Table 15-5. **Parameter Estimates of the Applicant's Final PPK Model (IFI)..**

NDA Multi-disciplinary Review and Evaluation, sNDA 205596, 205053, 214770
 NOXAFIL® (posaconazole) injection, delayed release tablet, PowderMix
 For prophylaxis of invasive fungal infections in pediatric patients 2 years of age and older
 For treatment of invasive aspergillosis in adults and pediatric patients 13 years and older

Table 15-5. Parameter Estimates of the Applicant's Final PPK Model (IFI).

Parameter	Estimate	RSE(%)	Shrinkage (%)
CL (L/h)	4.71	3.86	
V _c (L)	112	5.18	
KA (h ⁻¹)	0.212	17.9	
F1	0.826	5.58	
α for CL	0.624	9.86	
α for V _c	0.971	7.86	
IIV (CL) ^a	37.1	8.15	5
IIV (V _c) ^a	27.7	24.75	34
IIV (F1) ^b	2.02	18.9	42
Residual error (SD)	0.331	4.71	8

a: Expressed as a CV% using the following formula: $CV\% = \sqrt{OMEGA} \cdot 100$

b: The variability for F1 is shown as a standard deviation in the logit domain. This corresponds to 95% of subjects having F1 comprised between 8 and 99%.

Source: Applicant's PPK Model Report (IFI)

RSE: Residual Standard Error, CL: clearance, Q: intercompartmental clearance, V_c: volume of the central compartment, KA: absorption rate constant, α: exponent used for allometric scaling, IIV: inter-individual variability, F1: bioavailability, SD: standard deviation

Reviewer Comment: Note that the interindividual variability term on F is relatively high. This was caused by two patients with atypically low (<5%) estimated bioavailability, which was confirmed in the reviewer's analysis. The remaining patients has bioavailability >30% and thus 30% bioavailability was used as a cutoff in simulations.

Goodness-of-fit (GOF) plots for the Applicant's final PPK model are shown in Figure 15-1..

NDA Multi-disciplinary Review and Evaluation, sNDA 205596, 205053, 214770
NOXAFIL® (posaconazole) injection, delayed release tablet, PowderMix
For prophylaxis of invasive fungal infections in pediatric patients 2 years of age and older
For treatment of invasive aspergillosis in adults and pediatric patients 13 years and older

Figure 15-1. GOF Plots for Applicant's PPK Model (IFI).

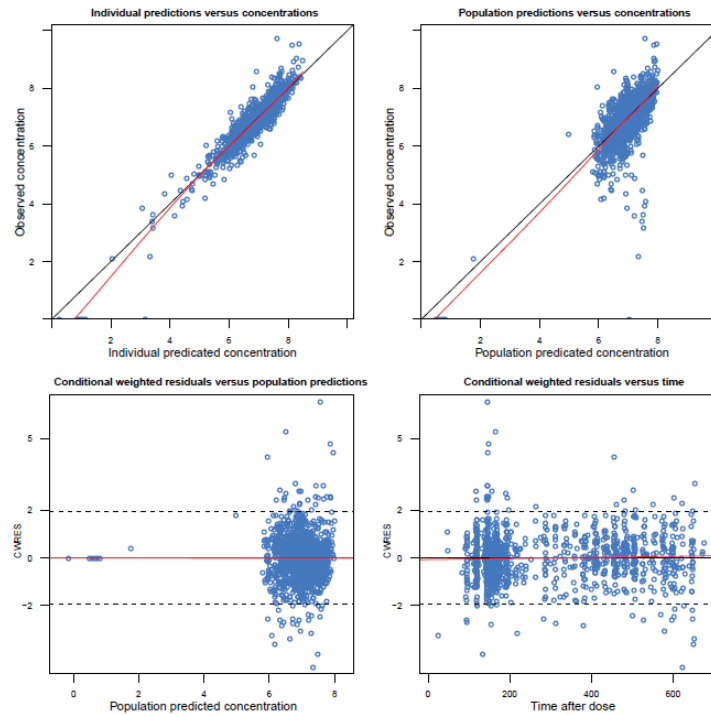

Source: Adapted from Applicant's PPK Model.

CWRES: Conditional Weighted Residuals. The red line represents the trend of the data relative to the line of unity (black line).

A visual predictive check (VPC) for the Applicant's final PPK model is shown in Figure 15-2., stratified by age group and formulation (IV or POWDERMIX).

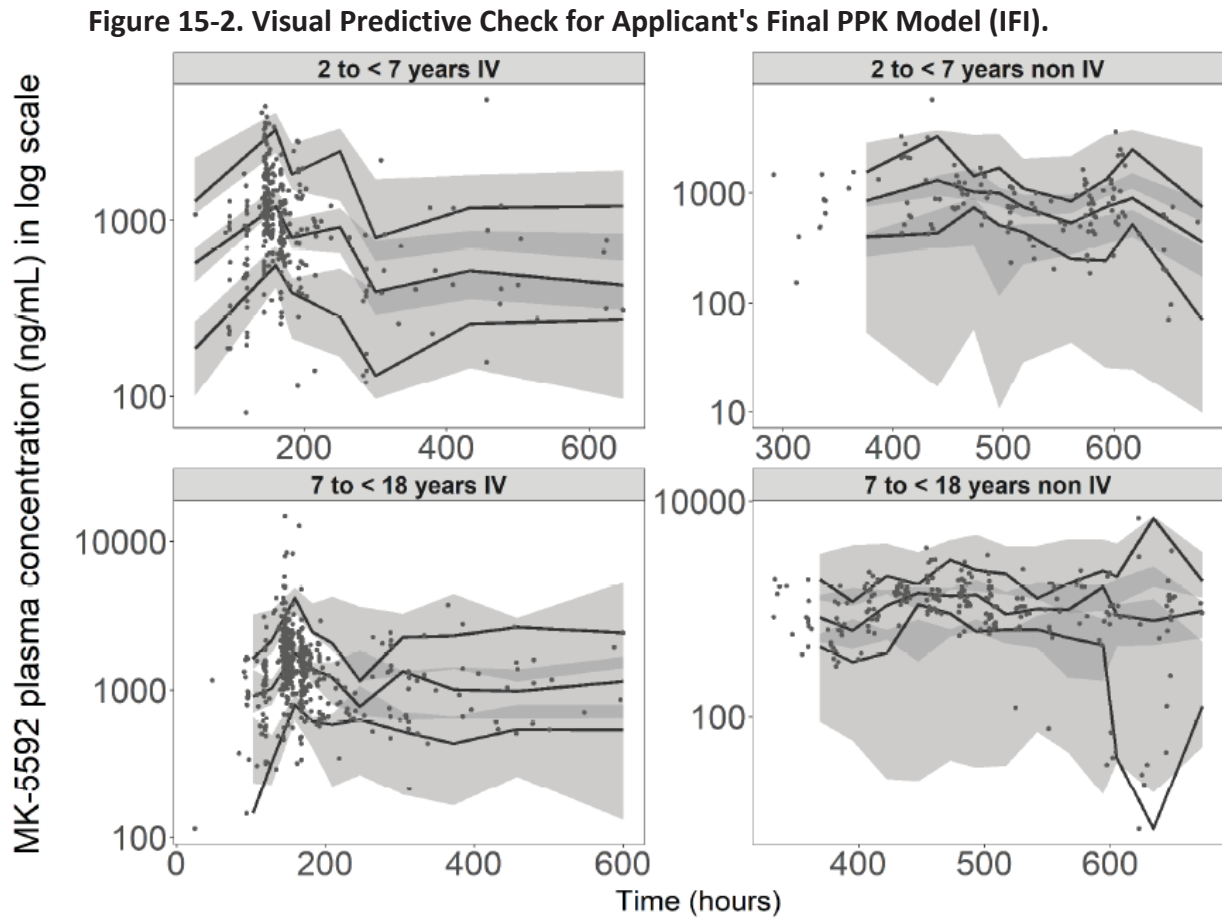

Source: Applicant's PPK Model (IFI)
MK-5592: Posaconazole, IV: intravenous
The dots represent observed posaconazole concentrations. The lines represent the 5th, 50th, and 95th percentiles of the observed data. The shaded areas represent the 90% prediction intervals of the 5th, 50th, and 95th percentiles generated from the PPK model.

Reviewer Comment: Note that the model appears to underpredict maximum concentration in patients receiving the IV formulation regardless of age. This finding may be a result of using a 1-compartment model instead of a 2-compartment model, which was used for the adult posaconazole PPK model. This may limit the pediatric PPK model's ability to predict C_{max}.

Overall, the Applicant's model appears to describe the collected PK data reasonably well. Both the GOF plots and VPC show reasonable agreement between observed concentrations and the model predictions. The Applicant's PPK model is acceptable for simulation of different dosing scenarios for exposure matching. The effective POS exposure for prophylaxis of IFIs was determined using C_{avg} as an exposure metric. The Applicant's PPK model adequately described CL and F, which are the most relevant parameters for C_{avg} determination.

NDA Multi-disciplinary Review and Evaluation, sNDA 205596, 205053, 214770
 NOXAFIL® (posaconazole) injection, delayed release tablet, PowderMix
 For prophylaxis of invasive fungal infections in pediatric patients 2 years of age and older
 For treatment of invasive aspergillosis in adults and pediatric patients 13 years and older

Treatment of Invasive Aspergillosis (IA)

The Applicant submitted Modeling and Simulation Report 05J0YY to provide a population PK (PPK) analysis of the posaconazole (POS) concentration data collected in multiple studies of POS in healthy volunteers and in patients for the prophylaxis of invasive fungal infections or treatment of invasive aspergillosis (IA) as shown in Table 15-6. Studies Included in Applicant's Final PPK Model (IA). The model included patients administered the POS intravenous injection (IVI) and delayed-release tablet (DRT).

Table 15-6. Studies Included in Applicant's Final PPK Model (IA)

Study number	Type	Subject N° Active Population	Dose regimen and dose	PK sampling scheme	Number of samples evaluable	Number of excluded samples
P04975 (Global)	Phase 1	Healthy N=16	SD 100 mg	rich	848	4
P05637 (Global)	Phase 1	Healthy N=19	SD 200 mg SD 400 mg MD 200 mg MD 400 mg	rich	675	0
P07764 (Global)	Phase 1	Healthy N=21	SD 400 mg	rich	1253	0
P07783 (Global)	Phase 1	Healthy N=25	SD 300 mg MD 300 mg	rich	526	0
P05615 (Global)	Phase 3	Prophylaxis N=231	MD 200 mg MD 300 mg	rich/ sparse	2140	13
P07691 (Global)	Phase 1	Healthy N=23	SD 100 mg	rich	505	0
PN111/P111 (Chinese)	Phase 1	Healthy N=18	SD 300 mg	rich	665	2
PN117/P117 (Chinese)	Phase 3	Prophylaxis N=65	MD 300 mg	rich/ sparse	498	1
PN067/P067 (Japanese)	Phase 1	Healthy N=28	SD & MD 200 mg MD 300 mg SD & MD 400 mg MD 600 mg	rich	670	0
PN101/P101 (Japanese)	Phase 3	Treatment Other Disease* N=76	MD 300 mg	rich/ sparse	835	2
PN120/P120 (Chinese)	Phase 1	Prophylaxis N=70	MD 300 mg	rich/ sparse	433	0
P05520 (Global)	Phase 1	Prophylaxis N=239	SD 200 mg SD 300 mg MD 200 mg MD 300 mg	rich/ sparse	1395	30
PN069/P069 (Global + Chinese)	Phase 3	Treatment of IA N=290	MD 300 mg	rich/ sparse	1098	23
Total		1121			11541	75
Evaluable		1092			11466	

* included 9 invasive aspergillosis patients.

Source: Applicant's PPK Report (IA)

NDA Multi-disciplinary Review and Evaluation, sNDA 205596, 205053, 214770
NOXAFIL® (posaconazole) injection, delayed release tablet, PowderMix
For prophylaxis of invasive fungal infections in pediatric patients 2 years of age and older
For treatment of invasive aspergillosis in adults and pediatric patients 13 years and older

The Applicant's final PPK model utilized a two-compartment model with allometric scaling on the central volume (V_c), total clearance (CL), intercompartmental clearance (Q), and peripheral volume (V_p), with estimated exponents. For the DRT, the absorption process was described using an absorption lag followed by zero-order absorption to a depot followed by first-order absorption to the central compartment as shown in Figure 15-3..

Figure 15-3. Applicant's Final PPK Model Structure (IA).

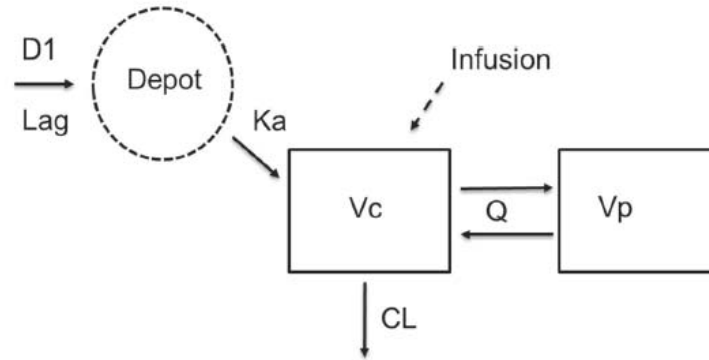

Note, Allometric scaling with estimated exponent is applied for CL , V_c , Q and V_p .

Source: Applicant's PPK Report (IA)

D1: Zero-order absorption duration, K_a : first-order absorption, V_c : central volume, CL : total clearance, Q : intercompartmental clearance, V_p : peripheral volume

Parameter estimates for the Applicant's final PPK model are shown in Figure 15-4..

NDA Multi-disciplinary Review and Evaluation, sNDA 205596, 205053, 214770
 NOXAFIL® (posaconazole) injection, delayed release tablet, PowderMix
 For prophylaxis of invasive fungal infections in pediatric patients 2 years of age and older
 For treatment of invasive aspergillosis in adults and pediatric patients 13 years and older

Figure 15-4. Parameter Estimates for Applicant's Final PPK Model (IA).

Parameter	Estimate	RSE (%)	Shrinkage
Fixed effects			
CL (L/h)	6.8	2.3	
V _c (L)	123	7.5	
Q (L/h)	52.7	5.6	
V _p (L)	250	3	
KA (1/h)	0.264	7.2	
D1 (h)	1.99	9.5	
F1	0.819	1.8	
Lag time (h)	0.419	0.7	
WT for CL and Q	0.531	13.9	
WT for V _c and V _p	1.41	5.3	
Covariate effects			
Food on F1	0.195	9.4	
HV ~ V _p	-0.2	21.3	
Other Disease ~ CL	-0.437	9.1	
IA ~ CL	-0.11	28.2	
HV ~ V _c	-0.543	12.5	
HV ~ D1	0.63	35	
Age ~ CL	-0.234	20.3	
Race-Chinese ~ CL	-0.248	14	
Random effects			
IIV CL (%CV)	45.5	2.45	13.9
IIV V _c (%CV)	109	3.8	40.3
IIV V _p (%CV)	22.4	7.8	63.7
IIV KA (%CV)	42.7	14.9	61.8
IIV D1 (%CV)	71.9	9.35	54.0
IIV F1 (%CV)	179	5.85	42.7
Residual error			
SD ^a (Ph1)	31.3	0.55	12.2
SD ^a (Ph3)	45.5	2.45	13.9

Source: Applicant's PPK Report (IA)

D1: Zero-order absorption duration, Ka: first-order absorption, V_c: central volume, CL: total clearance, Q: intercompartmental clearance, V_p: peripheral volume, WT: weight, IA: invasive aspergillosis, HV: healthy volunteer, F1: bioavailability, SD: standard deviation

Source: Applicant's PPK Model Report (IFI)

Reviewer Comment: Note that shrinkage for the interindividual variability terms on peripheral volume, absorption rate, and zero-order absorption duration are relatively high. However, these parameters are not the most relevant for the estimation of average concentration or area under the concentration-time curve, which is thought to be the relevant pharmacokinetic-pharmacodynamic index for POS.

Goodness-of-fit (GOF) plots for the Applicant's Final PPK model are shown in X.

NDA Multi-disciplinary Review and Evaluation, sNDA 205596, 205053, 214770
NOXAFIL® (posaconazole) injection, delayed release tablet, PowderMix
For prophylaxis of invasive fungal infections in pediatric patients 2 years of age and older
For treatment of invasive aspergillosis in adults and pediatric patients 13 years and older

Figure 15-5. GOF Plots for Applicant's PPK Model (IA).

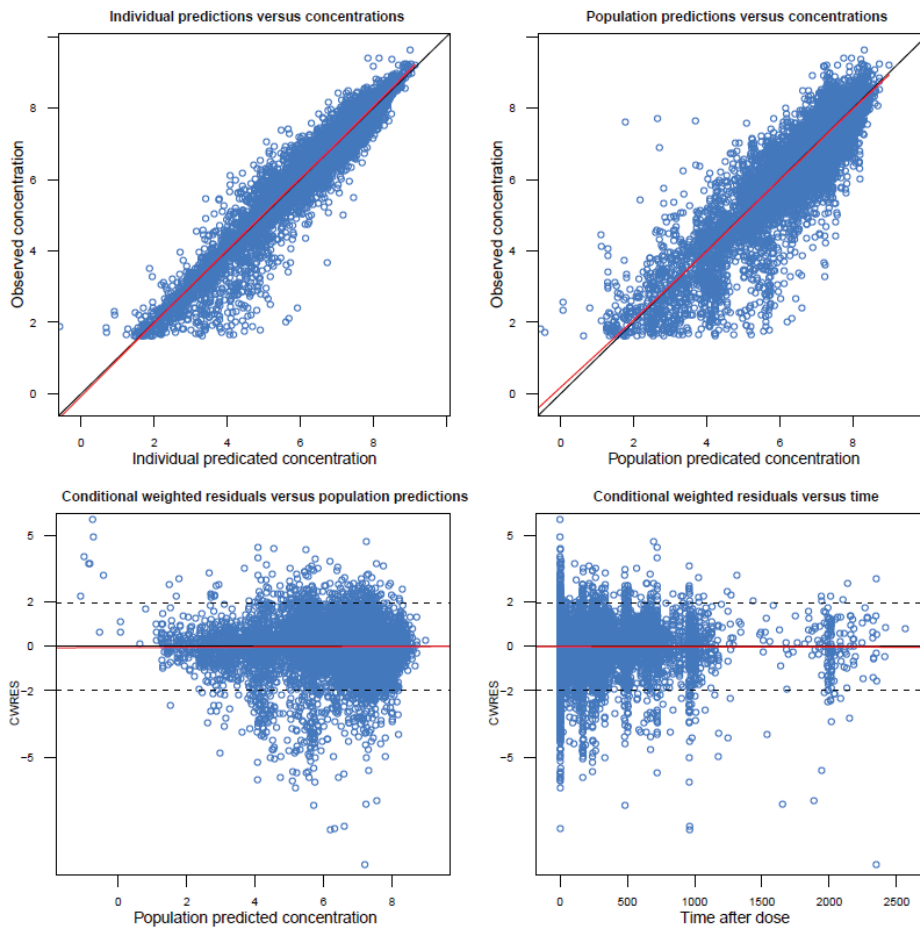

Source: Adapted from Applicant's Final PPK Model (IA)

A prediction-corrected visual predictive check (VPC) for the Applicant's final PPK model stratified by disease status is shown in Figure 15-6..

Figure 15-6. Prediction-Corrected Visual Predictive Check for Applicant's Final PPK Model (IA).

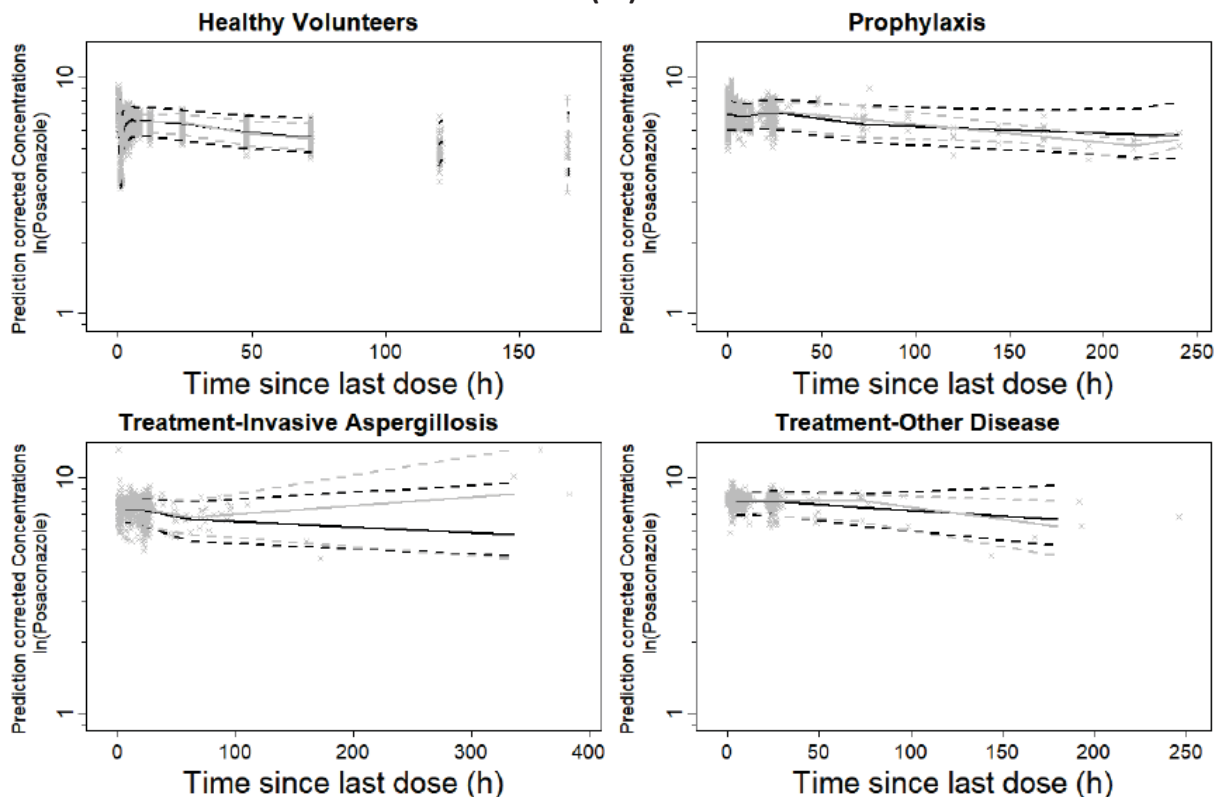

Source: Applicant's PPK Report (IA).

The dots represent observed posaconazole concentrations. The lines represent the 5th, 50th, and 95th percentiles of the observed data (gray line) and the model predictions (black line).

Reviewer Comment: The Applicant's final PPK model appears to describe the collected PK data reasonably well. The GOF plots and VPC both appear to show general agreement between the observed concentrations and model predictions.

Overall, the Applicant's PPK model is acceptable to provide post-hoc PK parameters to support exposure-response analysis.

15.2.6. *Reviewer's Analysis*

15.2.7. *Introduction*

Prophylaxis of Invasive IFI in Pediatric Patients

Because the standalone food-effect study used a prototype formulation and not the final to-be-marketed formulation (See Section 15.2.1 for more details), the characterization of the food effect was primarily informed by PPK analysis. In the Applicant's model, they determined that food was not a significant covariate on bioavailability. To inform labeling, the review team further assessed the covariate effect of food on bioavailability.

NDA Multi-disciplinary Review and Evaluation, sNDA 205596, 205053, 214770
 NOXAFIL® (posaconazole) injection, delayed release tablet, PowderMix
 For prophylaxis of invasive fungal infections in pediatric patients 2 years of age and older
 For treatment of invasive aspergillosis in adults and pediatric patients 13 years and older

Treatment of Invasive Aspergillosis

The review team used the Applicant’s developed PPK model to assess an exposure-response relationship for efficacy in the treatment of invasive aspergillosis (IA).

15.2.8. *Methods*

Prophylaxis of Invasive IFI in Pediatric Patients

Datasets

Datasets used in this analysis are summarized in Table 15-7. Datasets Used in PPK Analysis (IFI)..

Table 15-7. Datasets Used in PPK Analysis (IFI).

Study Number	Name	Link to EDR
05G9DG	Extension of Population Pharmacokinetic Analysis of MK-5592 (SCH 56592, Posaconazole, NOXAFIL®) across Oral POWDERMIX and IV formulations in Pediatric Subjects	\\CDSESUB1\evsprod\NDA205596\0090\m5\datasets\05g9dg\analysis\legacy

Software

NONMEM v7.4 was used for population pharmacokinetics modeling. Rv3.6.1 was used for data visualization and statistical analyses.

PPK Modeling

The review team further assessed the covariate effect of food on bioavailability for POS POWDERMIX. Using the Applicant’s final model, food was assessed as a covariate using a stepwise selection process. The covariate was considered in terms of change of objective function value and change in associated ETA. If a covariate was suspected to be significant, a bootstrap analysis where the model with the candidate covariate relationship included was used to estimate a 95% interval of parameter for the covariate relationship.

Treatment of Invasive Aspergillosis

Datasets

Datasets used in this analysis are summarized in Table 15-8. Datasets Used in PPK Analysis (IA)..

Table 15-8. Datasets Used in PPK Analysis (IA).

Study Number	Name	Link to EDR
05JOYY	A Population Pharmacokinetic Analysis of MK-5592 (SCH 56592, Posaconazole, NOXAFIL®) across Delayed-Release Tablet and Intravenous Solution Formulations used in the Prophylaxis and Treatment of Fungal Infections.	\\CDSESUB1\evsprod\NDA205596\0092\m5\datasets\05j0yy\analysis\legacy

Software

NONMEM v7.4 was used for population pharmacokinetics modeling. Rv3.6.1 was used for data visualization and statistical analyses.

Exposure-Response Analysis for Efficacy in the Treatment of IA

The review team assessed the relationship between exposure and response for efficacy in the treatment of IA using logistic regression. Average steady-state concentration (Cavg) was used as the exposure metric and was generated from post-hoc estimates using the Applicant’s final PPK model. The primary endpoint (all-cause mortality) and secondary endpoint (global response) measured in Study P069 were used as the efficacy metrics (See Statistics section for more details). The relationship between Cavg and efficacy was assessed using logistic regression. Formulation (initial route of administration selected), food coadministration, neutropenia, and organ impairment were considered as covariates in the analysis to account for potential confounding variables.

15.2.9. *Results - Food-effect analysis for POS POWDERMIX (IFI)*

The stepwise selection process to assess the effect of food on bioavailability is shown in Table 15-9. Stepwise Selection Process for Food on POS PK.. Food is a significant covariate on POS F at a significance level of p=0.042. Inclusion of food in the PPK model also reduced the inter-individual variability on bioavailability by 13%. However, the Applicant did not consider food to be a significant covariate because it did not meet their more stringent statistical significance criteria used in their modeling (p<0.01).

Table 15-9. Stepwise Selection Process for Food on POS PK.

Covariate Parameter	Final Model	Stepwise Addition
FOOD on F	Eta-F = 4.13 OFV = -954.688 F = 0.826	Eta-F = 3.58 OFV = -958.702 ΔOFV = -4.014 F = 0.719 Food-F= 1.2

Source: Reviewer’s analysis

Eta: Inter-individual variability, F: Bioavailability, OFV: Objective function value, Food-F: Effect of food on bioavailability

To further qualify the potential for a food effect, the review team performed a bootstrap analysis of the PPK model with the food-effect included. The bootstrapped median (90% interval) of the food-effect parameter was 1.20 (1.04, 1.48). Because the interval does not include 1 (unity), the bootstrap analysis cannot exclude the potential for food to have a significant effect on POS F.

Taken together, the PPK analysis cannot confirm whether food has a significant effect on POS PK. Note that the maximum bioavailability is similar in the Applicant’s final models with and without a food-effect on POS F: 83 without food-effect and 86% with food effect. Thus, the two models are not significantly different and the Applicant’s final model without the food effect

can be used for simulation. However, food may be necessary from a labeling perspective to optimize exposure.

15.2.10. Results - Exposure-Response Analysis for Efficacy in IA

The relationship between POS Cavg and survival (related to primary efficacy endpoint of all-cause mortality) is shown in Figure 15-7.. Most of the Cavg values are between 1000 and 4000 ng/mL. There did not appear to be a relationship between survival and POS Cavg. Survival rates remain high (80-90%) regardless of the interval of Cavg. There is no apparent trend toward increase or decrease in survival as POS Cavg increases. Food coadministration, neutropenia, and organ failure (renal impairment or hepatic impairment) did not significantly affect the exposures-response relationship for survival. In particular, renal impairment and hepatic impairment were rare in the dataset (<3%) and were unlikely to have any significant effect on the efficacy endpoints.

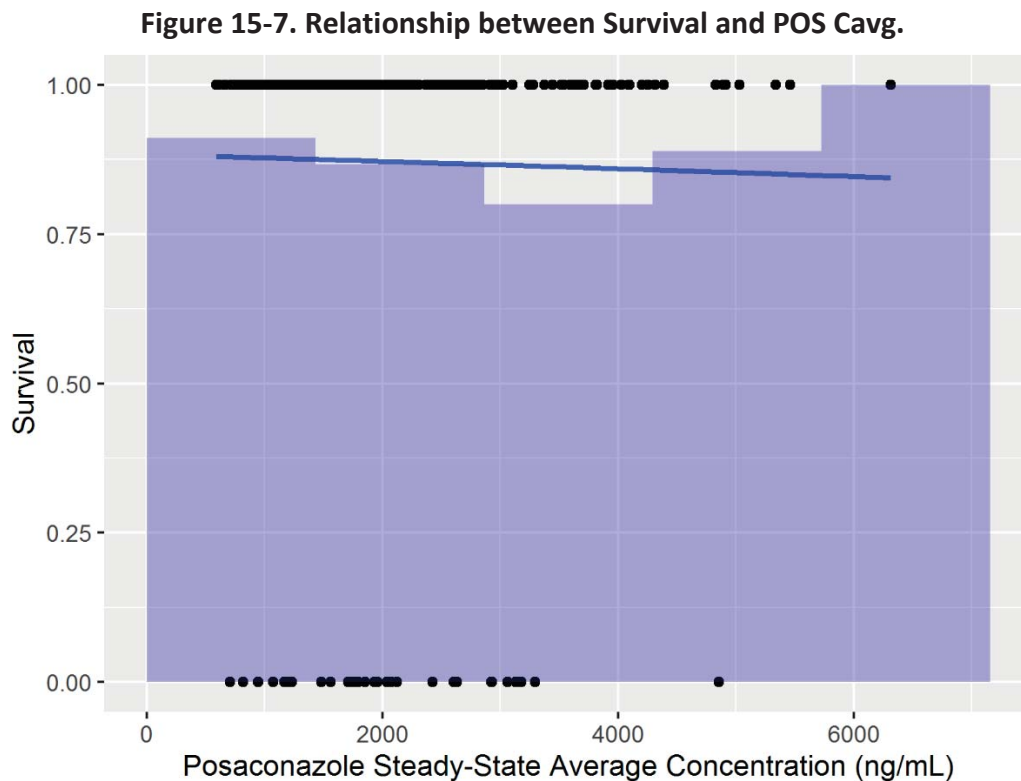

Source: Reviewer's Analysis

POS: Posaconazole, Cavg: steady-state average concentration

The plot was generated from a logistic regression of POS Cavg and survival (primary endpoint). The blue shaded area represents the average survival rate for a given interval of posaconazole average concentration.

To further characterize the exposure-response relationship for efficacy and to assess whether food coadministration affected the relationship, the review team assessed the exposure-

response relationship in patients who only received oral POS DRT to avoid confounding from intravenous administration. Table 15-10. Exposure-Response Relationship for Survival by Food Status in Oral Only Patients. demonstrates this exposure-response relationship stratified by food coadministration status. Food did not appear to independently impact survival. There are no major trends in survival between the only fasted, only fed, and the both fasted and fed groups. Within each food category, there is no consistent trend between POS Cavg and survival.

Table 15-10. Exposure-Response Relationship for Survival by Food Status in Oral Only Patients.

Only Fasted			Only Fed			Both Fed and Fasted		
POS Cavg	n	Survival	POS Cavg	n	Survival	POS Cavg	n	Survival
[0,1087)	4	100%	[0,1349)	6	83%	[0,1509)	18	100%
[1087,1611)	3	100%	[1349,1852)	5	80%	[15095,2078)	17	88%
[1611,2272)	3	100%	[1855,2407)	5	60%	[2078,2758)	18	100%
[2272,4098]	4	75%	[2407,4892]	6	83%	[2758,4854]	18	89%

Source: Reviewer’s Analysis

POS: Posaconazole, Cavg: steady-state average concentration, n: sample size

The exposure-response relationship for efficacy was further assessed by stratifying all combinations of formulations as shown in Figure 15-8.. There was a trend towards increased survival with increasing POS Cavg in the patients only administered POS IV. There was no consistent trend in patients administered POS by the other routes (oral or a combination of oral and IV). Baseline covariates did not have a significant effect on survival and were relatively balanced in each group. Within the IV only subset, the exposure-response relationship appears to be driven by 4 patients who survived with Cavg >4000 ng/mL. Upon further evaluation, it was determined that 3 of those 4 patients did not have proven or probable IA, which was not a requirement to be included in the primary efficacy analysis. Without those 3 patients, the positive trend between POS Cavg and survival in the IV only subset appears to be driven by chance. Additionally, choices of formulation and formulation switches were determined by clinician judgment. Thus, disease severity acts as a confounding variable and further diminishes the applicability of the trend between POS Cavg and survival observed in IV oral patients, which the review team determined is not clinically meaningful.

Figure 15-8. Exposure-Response Relationship for Survival Stratified by Route.

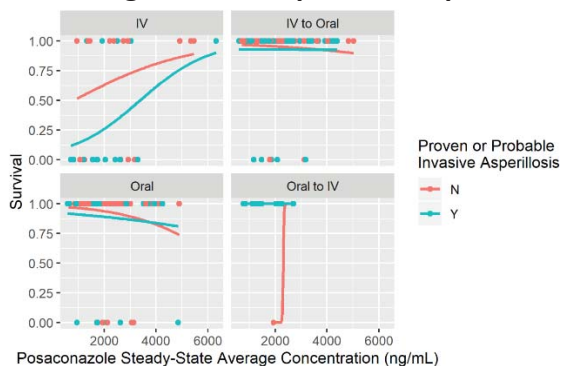

Route	Baseline Covariate Distribution				n
	CrCl <30	ALT >3x ULN	AST >3x ULN	Neutropenia	
IV	3%	3%	3%	53%	31 ^a
IV to Oral	0%	3%	2%	53%	107 ^b
Oral	2%	2%	0%	34%	108 ^c
Oral to IV	0%	0%	0%	62%	12 ^d

NDA Multi-disciplinary Review and Evaluation, sNDA 205596, 205053, 214770
 NOXAFIL® (posaconazole) injection, delayed release tablet, PowderMix
 For prophylaxis of invasive fungal infections in pediatric patients 2 years of age and older
 For treatment of invasive aspergillosis in adults and pediatric patients 13 years and older

Source: Reviewer’s Analysis

The panel above each graph represents the formulation(s) each patient received and the order they were given in (if multiple formulations were administered). The line represents the trend between POS Cavg and survival for each subgroup.

POS: Posaconazole, Cavg: steady-state average concentration, IV: Intravenous, N: Patients without proven or probable invasive aspergillosis, Y: Patients with proven or probable invasive aspergillosis, n = sample size for baseline covariates, ULN: upper limit of normal, CrCl: creatinine clearance in units of mL/min, ALT: alanine transaminase, AST: aspartate transaminase

^a: 32 measurements of neutrophils at baseline, ^b: 111 measurements of neutrophils at baseline, ^c:107 measurements of ALT at baseline, ^d:13 measurements of neutrophils at baseline

The review team also assessed the exposure-response relationship for the secondary endpoint (global response in patients with proven or probable IA) as shown in Figure 15-9.. There was no significant relationship between POS Cavg and global responses. The baseline covariates of interest were comparable within each administration group.

Figure 15-9. Exposure-Response Relationship for Global Response Stratified by Route.

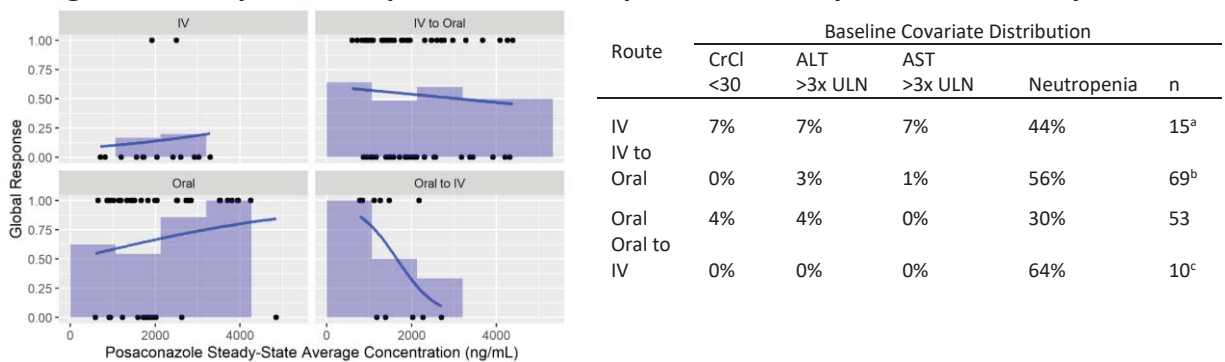

Source: Reviewer’s Analysis

The blue shaded area represents the average survival rate for a given interval of posaconazole average concentration.

POS: Posaconazole, Cavg: steady-state average concentration, IV: Intravenous, N: Patients without proven or probable invasive aspergillosis, Y: Patients with proven or probable invasive aspergillosis, n = sample size for baseline covariates, ULN: upper limit of normal, CrCl: creatinine clearance in units of mL/min, ALT: alanine transaminase, AST: aspartate transaminase

^a: 16 measurements of neutrophils at baseline, ^b: 70 measurements of neutrophils at baseline, ^c:11 measurements of neutrophils at baseline

Taken together, POS Cavg does not appear to affect clinical response (mortality or global response) to the treatment of IA. The exposure-response relationship for clinical response did not appear to be affected by potential confounders: route of administration, neutropenia, and organ dysfunction. At the same time, some elements of disease severity may be unexplained and could potentially confound the analysis. Overall, the proposed dose of POS (6 mg/kg twice daily then daily as a DRT or IVI) appears to produce exposures on the plateau of the exposure-response curve for efficacy.

NDA Multi-disciplinary Review and Evaluation, sNDA 205596, 205053, 214770
NOXAFIL® (posaconazole) injection, delayed release tablet, PowderMix
For prophylaxis of invasive fungal infections in pediatric patients 2 years of age and older
For treatment of invasive aspergillosis in adults and pediatric patients 13 years and older

Appears this way on original

15.3. Additional Clinical Analyses

15.3.1. Study P069 – Additional Tables

Deaths in Study P069

The following table summarizes all reported deaths (n= 197) during the trial period (185 deaths) and after the completion of the trial (12 deaths). Deaths are discussed in section 10.3.

Table 15-11 Study P069: Listing of Deaths (N = 197) by Cause of Death and Day of Death

Unique Subject Identifier	Age/Sex	Race	Country	Description of Actual Arm	Cause of Death	Day of Death	Duration on Treatment
(b) (6)	42 M	ASIAN	KOR	POS	Hypoxia	2	2
(b) (6)	71 F	WHITE	ISR	POS	Pulmonary alveolar hemorrhage	2	1
(b) (6)	53 F	MULTIPLE	COL	POS	Sepsis	3	2
(b) (6)	61 M	WHITE	BEL	POS	Fungal infection	5	3
(b) (6)	64 M	WHITE	FRA	POS	Acute respiratory distress syndrome	5	4
(b) (6)	46 F	WHITE	MEX	POS	Cerebral hemorrhage	5	3
(b) (6)	76 M	WHITE	BEL	VOR	Cerebral disorder	6	5
(b) (6)	57 M	WHITE	BEL	VOR	Aspergillus infection	6	6
(b) (6)	53 M	MULTIPLE	COL	VOR	Septic shock	6	5
(b) (6)	76 M	WHITE	ISR	POS	Septic shock	6	6
(b) (6)	63 F	WHITE	ISR	VOR	Lung infiltration	6	6
(b) (6)	68 M	WHITE	ISR	VOR	Pneumonia bacterial	6	5
(b) (6)	55 F	ASIAN	CHN	POS	Respiratory failure	6	5
(b) (6)	39 F	MULTIPLE	COL	VOR	Pancreatitis	7	5
(b) (6)	74 M	AMERICAN INDIAN OR ALASKA NATIVE	COL	VOR	Septic shock	7	5
(b) (6)	36 M	ASIAN	CHN	VOR	Cerebral hemorrhage	7	6
(b) (6)	73 M	WHITE	BEL	POS	Encephalopathy	7	5

NDA Multi-disciplinary Review and Evaluation, sNDA 205596, 205053, 214770
 NOXAFIL® (posaconazole) injection, delayed release tablet, PowderMix
 For prophylaxis of invasive fungal infections in pediatric patients 2 years of age and older
 For treatment of invasive aspergillosis in adults and pediatric patients 13 years and older

Unique Subject Identifier	Age/Sex	Race	Country	Description of Actual Arm	Cause of Death	Day of Death	Duration on Treatment
(b) (6)	62 F	ASIAN	KOR	POS	Septic shock	7	1
	69 M	WHITE	TUR	VOR	Septic shock	7	7
	69 M	WHITE	USA	POS	Interstitial lung disease	8	8
	28 M	WHITE	RUS	VOR	Multiple organ dysfunction syndrome	8	8
	68 M	WHITE	ISR	POS	Acute graft versus host disease	8	7
	58 F	WHITE	ISR	POS	Klebsiella sepsis	8	7
	44 F	ASIAN	TWN	VOR	Septic shock	8	6
	48 M	ASIAN	CHN	VOR	Gastrointestinal hemorrhage	8	7
	62 M	WHITE	HUN	VOR	Mucormycosis	8	7
	65 M	ASIAN	KOR	POS	Respiratory failure	9	6
	78 M	WHITE	DEU	VOR	Acute myeloid leukemia	9	4
	81 M	WHITE	DEU	POS	Death	9	8
	66 M	WHITE	DEU	VOR	Septic shock	9	9
	40 F	ASIAN	CHN	POS	Respiratory failure	9	5
	59 M	WHITE	ESP	POS	Pneumonia cytomegaloviral	9	7
	72 M	WHITE	CAN	VOR	Respiratory failure	10	9
	53 F	WHITE	BEL	VOR	Cardiac arrest	10	9
	63 F	WHITE	DEU	VOR	Cellulitis pharyngeal	10	6
	66 F	WHITE	RUS	POS	Cardiac failure acute	11	11
	62 M	MULTIPLE	COL	POS	Bacteremia	11	11
	49 M	WHITE	ISR	VOR	Escherichia bacteremia	11	11
	52 M	WHITE	RUS	POS	Bronchopulmonary aspergillosis	12	11
	68 F	ASIAN	USA	POS	Respiratory failure	12	4
	75 F	WHITE	DEU	POS	Sepsis	13	11
	45 M	WHITE	CAN	VOR	Sepsis	14	14

NDA Multi-disciplinary Review and Evaluation, sNDA 205596, 205053, 214770
 NOXAFIL® (posaconazole) injection, delayed release tablet, PowderMix
 For prophylaxis of invasive fungal infections in pediatric patients 2 years of age and older
 For treatment of invasive aspergillosis in adults and pediatric patients 13 years and older

Unique Subject Identifier	Age/Sex	Race	Country	Description of Actual Arm	Cause of Death	Day of Death	Duration on Treatment
(b) (6)	47 F	AMERICAN INDIAN OR ALASKA NATIVE	COL	VOR	Pneumonia fungal	14	12
	70 M	WHITE	BEL	VOR	Encephalopathy	14	10
	29 F	MULTIPLE	TUR	VOR	Immunodeficiency	14	2
	46 M	WHITE	ISR	VOR	Candida sepsis	14	14
	23 F	WHITE	TUR	VOR	Acute respiratory distress syndrome	15	3
	63 F	WHITE	RUS	VOR	Brain edema	16	14
	69 M	WHITE	BEL	POS	Septic shock	16	15
	68 F	WHITE	BEL	POS	Acute myeloid leukemia	16	11
	16 M	MULTIPLE	BRA	POS	Shock	16	15
	22 M	WHITE	MEX	VOR	Lymphocytic leukemia	16	15
	61 F	WHITE	DEU	VOR	Plasma cell myeloma	16	14
	37 M	WHITE	TUR	VOR	Sepsis	16	5
	40 M	WHITE	ISR	VOR	Septic shock	16	16
	35 M	WHITE	ISR	VOR	Septic shock	16	15
	65 F	ASIAN	TWN	POS	Respiratory failure	16	14
	68 M	WHITE	BEL	VOR	Septic shock	17	17
	62 M	WHITE	BEL	POS	Respiratory distress	17	17
	20 F	WHITE	TUR	VOR	Pulmonary alveolar hemorrhage	18	18
	63 F	WHITE	ISR	VOR	Acute myeloid leukemia	18	17
	38 F	WHITE	CHL	VOR	Acute myeloid leukemia	19	15
	66 F	WHITE	BEL	VOR	Acute respiratory failure	20	19
	67 M	WHITE	ISR	VOR	Mucormycosis	20	10
	70 M	WHITE	CAN	VOR	Acute myeloid leukemia	21	8
	63 M	WHITE	COL	VOR	Acute myeloid leukemia	21	21
	57 M	WHITE	TUR	POS	Engraftment syndrome	21	15

NDA Multi-disciplinary Review and Evaluation, sNDA 205596, 205053, 214770
 NOXAFIL® (posaconazole) injection, delayed release tablet, PowderMix
 For prophylaxis of invasive fungal infections in pediatric patients 2 years of age and older
 For treatment of invasive aspergillosis in adults and pediatric patients 13 years and older

Unique Subject Identifier	Age/Sex	Race	Country	Description of Actual Arm	Cause of Death	Day of Death	Duration on Treatment
(b) (6)	48 F	WHITE	TUR	VOR	Stenotrophomonas infection	21	20
	61 M	WHITE	ISR	VOR	Systemic mycosis	21	19
	91 F	MULTIPLE	COL	VOR	Respiratory failure	22	19
	60 M	WHITE	BEL	POS	Acute lymphocytic leukemia	22	4
	65 M	WHITE	BEL	VOR	Bronchopulmonary aspergillosis	23	11
	63 F	WHITE	DEU	VOR	Hydrocephalus	23	11
	79 F	ASIAN	TWN	POS	Septic shock	23	18
	35 F	ASIAN	SGP	POS	Acute lymphocytic leukemia	24	23
	34 F	WHITE	BRA	POS	Cardiac failure	24	10
	21 F	WHITE	MEX	POS	Respiratory failure	24	24
	80 M	WHITE	ITA	POS	General physical health deterioration	24	11
	62 M	WHITE	CAN	VOR	Chronic lymphocytic leukemia	25	24
	67 M	AMERICAN INDIAN OR ALASKA NATIVE	COL	VOR	Septic shock	25	20
	61 F	WHITE	TUR	POS	Pneumonia	27	10
	70 F	WHITE	ISR	POS	Hemoptysis	28	11
	19 M	WHITE	MEX	VOR	Pneumonia fungal	29	10
	64 F	WHITE	TUR	VOR	Septic shock	29	28
	39 M	WHITE	ISR	POS	Pulmonary hemorrhage	29	29
	62 F	WHITE	ITA	POS	Acute myeloid leukemia	31	8
	25 F	WHITE	BRA	VOR	Respiratory failure	32	14
	19 M	WHITE	CHL	VOR	Respiratory failure	33	32
	63 M	ASIAN	KOR	VOR	Malignant neoplasm progression	34	14
	84 F	WHITE	MEX	VOR	Abdominal sepsis	34	10
	56 F	WHITE	ISR	POS	Lung infiltration	35	32
	79 F	WHITE	DEU	VOR	Acute myeloid leukemia	36	22

NDA Multi-disciplinary Review and Evaluation, sNDA 205596, 205053, 214770
 NOXAFIL® (posaconazole) injection, delayed release tablet, PowderMix
 For prophylaxis of invasive fungal infections in pediatric patients 2 years of age and older
 For treatment of invasive aspergillosis in adults and pediatric patients 13 years and older

Unique Subject Identifier	Age/Sex	Race	Country	Description of Actual Arm	Cause of Death	Day of Death	Duration on Treatment
(b) (6)	57 M	MULTIPLE	COL	POS	Septic shock	37	9
	50 M	WHITE	ISR	VOR	Pneumonia	37	33
	67 M	MULTIPLE	COL	POS	Septic shock	38	38
	68 F	WHITE	ITA	POS	Septic shock	38	28
	57 M	WHITE	DEU	VOR	Arrhythmia	39	16
	76 M	WHITE	USA	POS	Hemorrhage intracranial	39	3
	71 F	WHITE	BEL	POS	Leukemia	41	31
	54 M	AMERICAN INDIAN OR ALASKA NATIVE	PER	VOR	Sepsis	41	40
	55 F	ASIAN	KOR	POS	Acute myeloid leukemia	41	40
	63 M	WHITE	HUN	VOR	Pneumonia	42	39
	58 M	WHITE	HUN	VOR	Multiple organ dysfunction syndrome	42	39
	72 M	WHITE	BEL	VOR	Acute myeloid leukemia	43	36
	46 F	WHITE	ISR	POS	Thrombotic thrombocytopenic purpura	43	40
	19 M	MULTIPLE	COL	POS	Precursor T-lymphoblastic lymphoma/leukemia refractory	44	28
	21 M	BLACK OR AFRICAN AMERICAN	USA	VOR	Pneumonia	45	5
	62 M	WHITE	ITA	VOR	Acute myeloid leukemia	45	37
	50 M	MULTIPLE	PER	POS	Septic shock	45	40
	51 M	WHITE	TUR	VOR	Sepsis	45	33
	51 M	WHITE	RUS	POS	Acute coronary syndrome	46	26
	57 F	WHITE	BEL	POS	Non-Hodgkin's lymphoma	47	2
	63 F	ASIAN	KOR	VOR	Aspergillus infection	47	35
	70 M	WHITE	USA	POS	Plasma cell myeloma	48	14
	71 M	WHITE	ROU	POS	Acute lymphocytic leukemia recurrent	48	8

NDA Multi-disciplinary Review and Evaluation, sNDA 205596, 205053, 214770
 NOXAFIL® (posaconazole) injection, delayed release tablet, PowderMix
 For prophylaxis of invasive fungal infections in pediatric patients 2 years of age and older
 For treatment of invasive aspergillosis in adults and pediatric patients 13 years and older

Unique Subject Identifier	Age/Sex	Race	Country	Description of Actual Arm	Cause of Death	Day of Death	Duration on Treatment
(b) (6)	48 F	MULTIPLE	COL	POS	Acute lymphocytic leukemia recurrent	50	24
	69 F	WHITE	BEL	POS	Respiratory failure	52	47
	57 F	ASIAN	KOR	VOR	Gastrointestinal hemorrhage	52	51
	53 M	MULTIPLE	COL	POS	Cerebral hemorrhage	53	53
	61 M	WHITE	BEL	VOR	Acute myeloid leukemia	53	52
	74 M	WHITE	ITA	VOR	Death	53	13
	60 M	WHITE	BEL	POS	Varicella zoster virus infection	54	24
	36 M	ASIAN	KOR	POS	Acute respiratory distress syndrome	54	53
	73 M	WHITE	ESP	VOR	Acute myeloid leukemia	54	48
	74 M	WHITE	USA	POS	Neuroendocrine tumour of the lung	55	39
	39 M	MULTIPLE	COL	VOR	B-cell type acute leukemia	55	55
	73 M	WHITE	MEX	POS	Clostridium difficile infection	55	55
	25 M	WHITE	ISR	VOR	Acute myelomonocytic leukemia	55	54
	41 F	AMERICAN INDIAN OR ALASKA NATIVE	COL	POS	B-cell type acute leukemia	55	5
	60 F	WHITE	MEX	POS	Acute pulmonary edema	57	57
	73 M	WHITE	ITA	POS	Leukemia	58	12
	41 M	WHITE	BRA	VOR	Systemic candida	58	58
	74 F	WHITE	BEL	VOR	Sinusitis	59	46
	66 M	WHITE	DEU	VOR	Plasma cell myeloma	59	16
	63 F	ASIAN	SGP	VOR	Lymphoma	60	54
	43 M	ASIAN	CHN	VOR	Respiratory failure	60	60
	61 M	WHITE	TUR	POS	Bacteremia	61	52
	46 F	WHITE	ITA	POS	Bronchopulmonary aspergillosis	62	12
	73 M	WHITE	FRA	POS	Multiple organ dysfunction syndrome	62	60

NDA Multi-disciplinary Review and Evaluation, sNDA 205596, 205053, 214770
 NOXAFIL® (posaconazole) injection, delayed release tablet, PowderMix
 For prophylaxis of invasive fungal infections in pediatric patients 2 years of age and older
 For treatment of invasive aspergillosis in adults and pediatric patients 13 years and older

Unique Subject Identifier	Age/Sex	Race	Country	Description of Actual Arm	Cause of Death	Day of Death	Duration on Treatment
(b) (6)	25 F	WHITE	ISR	POS	Enterococcal sepsis	62	62
	63 F	WHITE	BEL	POS	Acute myeloid leukemia	63	42
	47 F	WHITE	BEL	POS	Pneumocystis jirovecii pneumonia	64	63
	57 M	WHITE	BEL	VOR	Aspergillus infection	65	50
	71 F	ASIAN	KOR	POS	Diffuse large B-cell lymphoma	66	2
	46 F	WHITE	CHL	VOR	Death	66	25
	52 M	WHITE	TUR	VOR	Septic shock	66	57
	60 M	ASIAN	KOR	VOR	Septic shock	67	28
	43 F	ASIAN	KOR	VOR	Pneumonia viral	68	67
	52 F	WHITE	DEU	POS	Systemic candida	68	23
	21 F	AMERICAN INDIAN OR ALASKA NATIVE	COL	VOR	Acute lymphocytic leukemia	68	46
	62 M	WHITE	ISR	POS	Sepsis	70	70
	82 F	WHITE	HUN	POS	Cardiac failure	70	69
	55 F	WHITE	CAN	VOR	Pulmonary hemorrhage	73	64
	57 M	ASIAN	SGP	POS	Pneumonia	73	73
	55 M	WHITE	DEU	POS	Septic shock	77	7
	66 M	ASIAN	KOR	POS	Myelodysplastic syndrome	77	8
	66 M	WHITE	CAN	POS	Cardiac arrest	78	67
	66 M	WHITE	BEL	POS	Septic shock	78	76
	24 M	WHITE	TUR	POS	Diffuse large B-cell lymphoma refractory	78	77
	83 M	WHITE	ISR	POS	Septic shock	80	79
	41 M	AMERICAN INDIAN OR ALASKA NATIVE	COL	POS	Respiratory failure	80	79
	70 M	WHITE	USA	VOR	Aplastic anemia	82	16
	22 M	WHITE	BRA	POS	Pseudomembranous colitis	82	80

NDA Multi-disciplinary Review and Evaluation, sNDA 205596, 205053, 214770
 NOXAFIL® (posaconazole) injection, delayed release tablet, PowderMix
 For prophylaxis of invasive fungal infections in pediatric patients 2 years of age and older
 For treatment of invasive aspergillosis in adults and pediatric patients 13 years and older

Unique Subject Identifier	Age/Sex	Race	Country	Description of Actual Arm	Cause of Death	Day of Death	Duration on Treatment
(b) (6)	63 F	WHITE	ISR	POS	Acute myeloid leukemia	82	81
	33 M	WHITE	MEX	VOR	Acute lymphocytic leukemia	83	56
	20 F	WHITE	ISR	VOR	Acute myeloid leukemia	83	27
	60 M	WHITE	USA	POS	Chronic obstructive pulmonary disease	85	73
	36 F	WHITE	RUS	POS	Death	87	65
	79 F	WHITE	USA	VOR	Death	89	62
	52 F	WHITE	ISR	VOR	Disseminated cytomegaloviral infection	90	85
	29 M	AMERICAN INDIAN OR ALASKA NATIVE	COL	VOR	Pulmonary hemorrhage	90	89
	31 F	WHITE	RUS	VOR	Death	91	90
	52 M	MULTIPLE	COL	POS	Pneumonia	93	89
	74 F	WHITE	MEX	POS	Acute myeloid leukemia	93	60
	60 M	ASIAN	TWN	POS	Pneumonia	96	88
	74 F	WHITE	ITA	VOR	Cerebral hematoma	98	82
	33 F	WHITE	BEL	POS	Aspergillus infection	99	41
	69 F	WHITE	BRA	POS	Septic shock	100	88
	78 F	WHITE	DEU	VOR	Acute myeloid leukemia	100	57
	64 F	WHITE	USA	POS	Death	102	17
	62 F	WHITE	ISR	VOR	Acute myeloid leukemia	104	4
	72 F	WHITE	HUN	POS	Hemorrhage intracranial	108	92
	80 F	WHITE	BEL	POS	Clostridial infection	109	50
	68 M	ASIAN	CHN	POS	Pneumonia	110	93
	41 M	MULTIPLE	COL	VOR	Pneumonia bacterial	114	31
	70 M	ASIAN	KOR	POS	Sepsis	116	98
	71 F	WHITE	USA	POS	Myelodysplastic syndrome	120	90
	50 M	WHITE	CAN	POS	Graft versus host disease in gastrointestinal tract	120	84

NDA Multi-disciplinary Review and Evaluation, sNDA 205596, 205053, 214770
 NOXAFIL® (posaconazole) injection, delayed release tablet, PowderMix
 For prophylaxis of invasive fungal infections in pediatric patients 2 years of age and older
 For treatment of invasive aspergillosis in adults and pediatric patients 13 years and older

Unique Subject Identifier	Age/Sex	Race	Country	Description of Actual Arm	Cause of Death	Day of Death	Duration on Treatment
(b) (6)	38 M	WHITE	ESP	POS	Lymphoma	125	91
	19 F	MULTIPLE	COL	POS	Febrile neutropenia	132	90
	68 F	WHITE	ISR	VOR	Mucormycosis	139	86
	60 M	MULTIPLE	COL	VOR	Septic shock	145	85
	68 M	MULTIPLE	PER	VOR	Acute myeloid leukemia	154	84
	65 F	ASIAN	SGP	VOR	Plasma cell myeloma	161	85
	62 M	WHITE	ISR	POS	Sepsis	161	92
	22 F	MULTIPLE	COL	POS	Acute myeloid leukemia recurrent	186	85
	26 M	ASIAN	KOR	VOR	Death	224	4

Source: OCS Analysis Studio, Listing Table Tool.
 Subjects - Dataset: Demographics; Filter: ITTFL = 'Y', DTHFL = 'Y'.

Table 15-12 summarizes TEAEs of special interest (referred to as “Tier 1” adverse events by the Applicant) in the POS and VOR treatment groups. Hepatobiliary Disorders and potential Hy’s Law cases (also designated as Tier 1 adverse events by the Applicant) are discussed in section 10.3.

Table 15-12 Study P069: TEAEs of Special Interest by Treatment Group

	Posaconazole (N=288)	Voriconazole (N=287)	Total (N=575)
Subjects with ≥ 1 TEAE	131 (45.5)	141(49.1)	272 (47.3)
Nervous system disorders	60 (20.8)	53 (18.5)	113 (19.7)
Dizziness	22 (7.6)	12 (4.2)	34 (5.9)
Tremor	7 (2.4)	9 (3.1)	16 (2.8)
Syncope	6 (2.1)	9 (3.1)	15 (2.6)
Encephalopathy	3 (1.0)	8 (2.8)	11 (1.9)
Seizure	3 (1.0)	5 (1.7)	8 (1.4)
Paraesthesia	3 (1.0)	4 (1.4)	7 (1.2)
Hypoaesthesia	3 (1.0)	3 (1.0)	6 (1.0)
Depressed level of consciousness	4 (1.4)	1 (0.3)	5 (0.9)
Dysgeusia	2 (0.7)	2 (0.7)	4 (0.7)
Cognitive disorder	2 (0.7)	1 (0.3)	3 (0.5)
Neuropathy peripheral	2 (0.7)	1 (0.3)	3 (0.5)
Brain oedema	0	2 (0.7)	2 (0.3)

	Posaconazole (N=288)	Voriconazole (N=287)	Total (N=575)
Peripheral sensory neuropathy	2 (0.7)	0	2 (0.3)
Posterior reversible encephalopathy syndrome	1 (0.3)	1 (0.3)	2 (0.3)
Altered state of consciousness	0	1 (0.3)	1 (0.2)
Anosmia	1 (0.3)	0	1 (0.2)
Asterixis	0	1 (0.3)	1 (0.2)
Cerebral disorder	0	1 (0.3)	1 (0.2)
Disturbance in attention	0	1 (0.3)	1 (0.2)
Dysaesthesia	1 (0.3)	0	1 (0.2)
Dysarthria	0	1 (0.3)	1 (0.2)
Dyskinesia	0	1 (0.3)	1 (0.2)
Hypokinesia	0	1 (0.3)	1 (0.2)
Loss of consciousness	0	1 (0.3)	1 (0.2)
Mental impairment	1 (0.3)	0	1 (0.2)
Myoclonus	0	1 (0.3)	1 (0.2)
Neurotoxicity	0	1 (0.3)	1 (0.2)
Nystagmus	0	1 (0.3)	1 (0.2)
Paraparesis	1 (0.3)	0	1 (0.2)
Parosmia	1 (0.3)	0	1 (0.2)
Presyncope	1 (0.3)	0	1 (0.2)
Psychomotor hyperactivity	1 (0.3)	0	1 (0.2)
Pyramidal tract syndrome	1 (0.3)	0	1 (0.2)
Speech disorder	0	1 (0.3)	1 (0.2)
Status epilepticus	1 (0.3)	0	1 (0.2)
Stupor	1 (0.3)	0	1 (0.2)
Taste disorder	1 (0.3)	0	1 (0.2)
Wernicke's encephalopathy	0	1 (0.3)	1 (0.2)
Skin and subcutaneous tissue disorders	46 (16.0)	53 (18.5)	99 (17.2)
Rash	28 (9.7)	30 (10.5)	58 (10.1)
Erythema	5 (1.7)	10 (3.5)	15 (2.6)
Dermatitis	6 (2.1)	5 (1.7)	11 (1.9)
Skin exfoliation	2 (0.7)	2 (0.7)	4 (0.7)
Drug eruption	2 (0.7)	1 (0.3)	3 (0.5)
Urticaria	1 (0.3)	2 (0.7)	3 (0.5)
Angioedema	0	2 (0.7)	2 (0.3)
Dermatitis exfoliative generalized	2 (0.7)	0	2 (0.3)
Photosensitivity reaction	1 (0.3)	1 (0.3)	2 (0.3)
Skin ulcer	1 (0.3)	1 (0.3)	2 (0.3)
Toxic skin eruption	0	2 (0.7)	2 (0.3)
Pruritus allergic	0	1 (0.3)	1 (0.2)

	Posaconazole (N=288)	Voriconazole (N=287)	Total (N=575)
Skin irritation	0	1 (0.3)	1 (0.2)
Skin necrosis	1 (0.3)	0	1 (0.2)
Skin reaction	1 (0.3)	0	1 (0.2)
Psychiatric disorders	35 (12.2)	47 (16.4)	82 (14.3)
Hallucination	6 (2.1)	15 (5.2)	21 (3.7)
Hallucination visual	2 (0.7)	6 (2.1)	8 (1.4)
Hallucination hypnagogic	0	1 (0.3)	1 (0.2)
Confusional state	10 (3.5)	16 (5.6)	26 (4.5)
Depression	8 (2.8)	4 (1.4)	12 (2.1)
Agitation	5 (1.7)	6 (2.1)	11 (1.9)
Delirium	3 (1.0)	2 (0.7)	5 (0.9)
Depressed mood	2 (0.7)	3 (1.0)	5 (0.9)
Mental status changes	0	4 (1.4)	4 (0.7)
Panic attack	1 (0.3)	1 (0.3)	2 (0.3)
Abnormal behaviour	0	1 (0.3)	1 (0.2)
Abnormal dreams	1 (0.3)	0	1 (0.2)
Bipolar I disorder	0	1 (0.3)	1 (0.2)
Disorientation	1 (0.3)	0	1 (0.2)
Nightmare	1 (0.3)	0	1 (0.2)
Eye disorders	19 (6.6)	36 (12.5)	55 (9.6)
Visual impairment	14 (4.9)	21 (7.3)	35 (6.1)
Photopsia	2 (0.7)	6 (2.1)	8 (1.4)
Dyschromatopsia	0	6 (2.1)	6 (1.0)
Vitreous floaters	1 (0.3)	2 (0.7)	3 (0.5)
Blepharitis	1 (0.3)	1 (0.3)	2 (0.3)
Photophobia	0	2 (0.7)	2 (0.3)
Uveitis	2 (0.7)	0	2 (0.3)
Blindness	0	1 (0.3)	1 (0.2)
Blindness unilateral	0	1 (0.3)	1 (0.2)
Choroidal sclerosis	1 (0.3)	0	1 (0.2)
Iridocyclitis	0	1 (0.3)	1 (0.2)
Pupils unequal	0	1 (0.3)	1 (0.2)
Vascular disorders	22 (7.6)	20 (7.0)	42 (7.3)
Hypotension	20 (6.9)	19 (6.6)	39 (6.8)
Orthostatic hypotension	2 (0.7)	1 (0.3)	3 (0.5)
Immune system disorders	2 (0.7)	2 (0.7)	4 (0.7)
Drug hypersensitivity	2 (0.7)	2 (0.7)	4 (0.7)
Endocrine disorders	1 (0.3)	1 (0.3)	2 (0.3)
Adrenal insufficiency	1 (0.3)	1 (0.3)	2 (0.3)

NDA Multi-disciplinary Review and Evaluation, sNDA 205596, 205053, 214770
 NOXAFIL® (posaconazole) injection, delayed release tablet, PowderMix
 For prophylaxis of invasive fungal infections in pediatric patients 2 years of age and older
 For treatment of invasive aspergillosis in adults and pediatric patients 13 years and older

	Posaconazole (N=288)	Voriconazole (N=287)	Total (N=575)
--	-------------------------	-------------------------	------------------

Source: OCS Analysis Studio, Custom Table Tool.

Columns - Dataset: Demographics; Filter: TRTFL = 'Y'.

Table Section 1 - Dataset: Adverse Events; Filter: TRTEMFL = 'Y', TIER1FL = 'Y'.

Adverse events are reported from the first dose of study treatment through 30 days after the last dose.

PT Visual impairment includes vision blurred, visual acuity reduced, visual impairment

PT Rash includes rash erythematous, rash macular, rash maculo-papular, rash papular, rash pruritic, rash vesicular

This is a representation of an electronic record that was signed electronically. Following this are manifestations of any and all electronic signatures for this electronic record.

/s/

CHRISTOPHER L SMITH
05/28/2021 07:46:29 PM

SUMATHI NAMBIAR
05/28/2021 10:31:51 PM