

**CENTER FOR DRUG EVALUATION AND
RESEARCH**

APPLICATION NUMBER:

215352Orig1s000

LABELING

HIGHLIGHTS OF PRESCRIBING INFORMATION
These highlights do not include all the information needed to use MYDCOMBI® safely and effectively. See full prescribing information for MYDCOMBI.

MYDCOMBI (tropicamide and phenylephrine hydrochloride ophthalmic spray) 1%/2.5%, for topical ophthalmic use
Initial U.S. Approval: 2023

INDICATIONS AND USAGE
MYDCOMBI is a combination of tropicamide, an anticholinergic, and phenylephrine hydrochloride, an alpha-1 adrenergic receptor agonist indicated to induce mydriasis for diagnostic procedures and in conditions where short term pupil dilation is desired (1)

DOSAGE AND ADMINISTRATION
• Administer one metered spray to the cornea of each eye to be dilated. Repeat after 5 minutes. (2.1)
• In pediatric patients younger than 1 year old, administer one metered spray to the cornea of each eye to be dilated, up to a maximum of 3 sprays per eye per day (2.1)

DOSAGE FORMS AND STRENGTHS
Ophthalmic spray containing tropicamide 1% and phenylephrine hydrochloride 2.5%. Each metered spray delivers 0.008 mL which contains 0.08 mg tropicamide and 0.2 mg phenylephrine HCl (3)

CONTRAINDICATIONS
• Known hypersensitivity to any component of the formulation (4.1)

WARNINGS AND PRECAUTIONS
• Not for Injection: Topical ophthalmic use (5.1)
• Significant Elevations in Blood Pressure: Caution in pediatric patients less than 5 years of age, and in patients with cardiovascular disease or hyperthyroidism. In patients at high risk, monitor blood pressure post treatment (5.2)

- **Central Nervous System Disturbances:** Caution in pediatric patients where rare incidences of central nervous system disturbances have been reported (5.3)
- **Intraocular Pressure:** May produce a transient elevation (5.4)
- **Rebound Miosis:** Reported 1 day after administration (5.5)

ADVERSE REACTIONS
• Most common ocular adverse reactions include transient blurred vision, reduced visual acuity, photophobia, superficial punctate keratitis, and mild eye discomfort. Increased intraocular pressure has been reported following the use of mydriatics (6.1)
• Systemic adverse reactions including dryness of the mouth, tachycardia, headache, allergic reactions, nausea, vomiting, pallor, central nervous system disturbances and muscle rigidity have been reported with the use of tropicamide (6.2)

To report SUSPECTED ADVERSE REACTIONS, contact Eyeovia, Inc. at 1-833-393-6684 or FDA at 1-800-FDA-1088 or www.fda.gov/medwatch

DRUG INTERACTIONS
• **Atropine-like Drugs:** May exaggerate the adrenergic pressor response (7.1)
• **Cholinergic Agonists and Ophthalmic Cholinesterase Inhibitors:** May interfere with the antihypertensive action of carbachol, pilocarpine, or ophthalmic cholinesterase inhibitors (7.2)
• **Potent Inhalation Anesthetic Agents:** May potentiate cardiovascular depressant effects of (7.3)

USE IN SPECIFIC POPULATIONS
Pediatric Use: May rarely cause central nervous system disturbances which may be dangerous in pediatric patients (5.3, 8.4)

See 17 for **PATIENT COUNSELING INFORMATION**

Revised: 5/2023

FULL PRESCRIBING INFORMATION: CONTENTS*

1	INDICATIONS AND USAGE
2	DOSAGE AND ADMINISTRATION
2.1	Recommended Dosage
2.2	Administration Instructions
3	DOSAGE FORMS AND STRENGTHS
4	CONTRAINDICATIONS
4.1	Known Hypersensitivity
5	WARNINGS AND PRECAUTIONS
5.1	Topical Ophthalmic Use
5.2	Blood Pressure Elevation
5.3	Central Nervous System Disturbances
5.4	Intraocular Pressure
5.5	Rebound Miosis
6	ADVERSE REACTIONS
6.1	Ocular Adverse Reactions
6.2	Systemic Adverse Reactions

7	DRUG INTERACTIONS
7.1	Agents That May Exaggerate Pressor Responses
7.2	Cholinergic Agonists and Ophthalmic Cholinesterase Inhibitors
7.3	Potent Inhalation Anesthetic Agents
8	USE IN SPECIFIC POPULATIONS
8.1	Pregnancy
8.2	Lactation
8.4	Pediatric Use
8.5	Geriatric Use
10	OVERDOSAGE
11	DESCRIPTION
12	CLINICAL PHARMACOLOGY
12.1	Mechanism of Action
12.2	Pharmacodynamics
14	CLINICAL STUDIES
16	HOW SUPPLIED/STORAGE AND HANDLING
17	PATIENT COUNSELING INFORMATION

*Sections or subsections omitted from the full prescribing information are not listed.

FULL PRESCRIBING INFORMATION

1 INDICATIONS AND USAGE

MYDCOMBI (tropicamide and phenylephrine hydrochloride ophthalmic spray) 1% / 2.5% is indicated to induce mydriasis for diagnostic procedures and in conditions where short term pupil dilation is desired.

2 DOSAGE AND ADMINISTRATION

2.1 Recommended Dosage

Administer one metered spray to the cornea of each eye to be dilated. Repeat after 5 minutes.

Pediatric Patients Younger Than 1 Year Old

In pediatric patients younger than 1 year old, administer one metered spray to the cornea of each eye to be dilated, up to a maximum of 3 sprays per eye per day.

2.2 Administration Instructions

The following steps should be followed sequentially:

- A. Load the MYDCOMBI dispenser by depressing the FILL BUTTON at the top of the dispenser once.

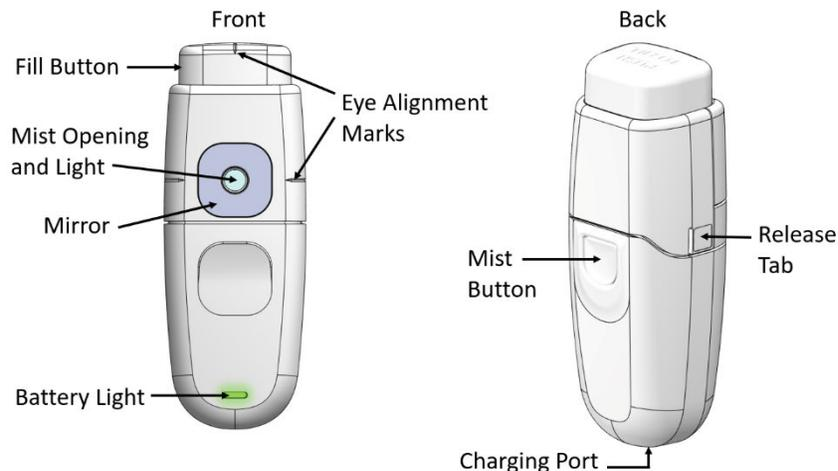

Figure 1: MYDCOMBI Dispenser Front (L) and Back (R) View

- B. Hold MydCombi™ dispenser with thumb over Mist Button, wrapping other fingers around base.
- C. Bring MydCombi™ dispenser to patient's eye with Mirror facing the eye.
 - The dispenser should be as close as patient's nose.

- To prevent blinking, use your other hand to gently pull lower eyelid down or ask patient to pull her/his lid down.
- D. Aim Mist Opening toward the center of eye.
- E. Confirm Alignment Marks (on the Fill Button and the cartridge side) align with the center of eye.
 - Ask patient to confirm when their eye is centered on the BLUE Mirror.*If patient is having trouble centering their eye on the blue light, ask that they look up, then look at the BLUE Mirror.*
- F. Firmly press and release Mist Button.
 - The drug solution should gently wet the eye. Repeat steps A to F if needed.
- G. Administer a second metered spray after 5 minutes to each dilated eye.
- H. Repeat steps A to G for the contralateral eye if it is to be dilated.

3 DOSAGE FORMS AND STRENGTHS

MYDCOMBI is a sterile, clear, colorless, topical ophthalmic spray containing tropicamide 1% (w/w) and phenylephrine hydrochloride 2.5% (w/w). Each metered spray delivers 0.008 mL which contains 0.08 mg tropicamide and 0.2 mg phenylephrine hydrochloride.

4 CONTRAINDICATIONS

4.1 Known Hypersensitivity

Contraindicated in persons showing known hypersensitivity to any component of the formulation.

5 WARNINGS AND PRECAUTIONS

5.1 Topical Ophthalmic Use

MYDCOMBI is not indicated for injection.

5.2 Blood Pressure Elevation

Caution should be exercised with the use of MYDCOMBI in pediatric patients less than 5 years of age and patients with hyperthyroidism, or cardiovascular disease. The post-treatment blood pressure of patients with cardiac and endocrine diseases and any patients who develop symptoms should be carefully monitored.

5.3 Central nervous system disturbances

Tropicamide in MYDCOMBI may cause CNS disturbances which may be dangerous in pediatric patients. The possibility of psychotic reactions and behavioral disturbances due to hypersensitivity to anticholinergic drugs should be considered.

5.4 Intraocular Pressure

Mydriatics may produce a transient elevation of intraocular pressure.

5.5 Rebound Miosis

Rebound miosis has been reported one day after receiving phenylephrine hydrochloride ophthalmic solution, and re-administration of the drug produced a lesser mydriatic effect.

6 ADVERSE REACTIONS

Because clinical trials are conducted under widely varying conditions, adverse reaction rates observed in the clinical trials of a drug cannot be directly compared to rates in the clinical trials of another drug and may not reflect the rates observed in practice. The most common adverse reactions (incidence < 2%) were transient blurred vision, reduced visual acuity, photophobia, and mild eye discomfort.

6.1 Ocular Adverse Reactions

Transient blurred vision, reduced visual acuity, photophobia, superficial punctate keratitis, and mild eye discomfort may occur. Increased intraocular pressure has been reported following the use of mydriatics.

6.2 Systemic Adverse Reactions

Dryness of the mouth, tachycardia, headache, allergic reactions, nausea, vomiting, pallor, central nervous system disturbances and muscle rigidity have been reported with the use of tropicamide. Psychotic reactions, behavioral disturbances, and vasomotor or cardiorespiratory collapse in children have been reported with the use of anticholinergic drugs.

A marked increase in blood pressure has been reported with the use of phenylephrine, particularly, but not limited to, low weight premature neonates, infants, and hypertensive patients.

7 DRUG INTERACTIONS

7.1 Agents That May Exaggerate Pressor Responses

Phenylephrine in MYDCOMBI may enhance the pressor effects of atropine-like drugs and induce tachycardia in some patients.

7.2 Cholinergic Agonists And Ophthalmic Cholinesterase Inhibitors

Tropicamide in MYDCOMBI may interfere with the antihypertensive action of carbachol, pilocarpine, or ophthalmic cholinesterase inhibitors.

7.3 Potent Inhalation Anesthetic Agents

Phenylephrine in MYDCOMBI may potentiate the cardiovascular depressant effects of some inhalation anesthetic agents.

8 USE IN SPECIFIC POPULATIONS

8.1 Pregnancy

Risk Summary

There are no available data on MYDCOMBI use in pregnant women or animals to inform any drug-associated risks. It is also not known whether tropicamide or phenylephrine can cause fetal harm when administered to a pregnant woman or can affect reproduction capacity. MYDCOMBI should be given to a pregnant woman only if clearly needed.

8.2 Lactation

Risk Summary

There are no data on the presence of tropicamide or phenylephrine in human milk from the administration of MYDCOMBI, the effects on the breastfed infant, or the effects on milk production. The developmental and health benefits of breastfeeding should be considered along with the mother's clinical need for MYDCOMBI and any potential adverse effects on the breastfed child from MYDCOMBI.

8.4 Pediatric Use

Tropicamide in MYDCOMBI may rarely cause CNS disturbances which may be dangerous in pediatric patients. Psychotic reactions, behavioral disturbances, and vasomotor or cardiorespiratory collapse in children have been reported with the use of anticholinergic drugs [*see Warnings and Precautions (5.3)*].

8.5 Geriatric Use

No overall differences in safety or effectiveness of MYDCOMBI have been observed between patients 65 years of age and older and younger adult patients.

10 OVERDOSAGE

Overdosage of MYDCOMBI may cause a rapid rise in blood pressure. It may also cause headache, anxiety, nausea and vomiting, and ventricular arrhythmias. Prompt injection of a rapidly acting alpha-adrenergic blocking agent such as phentolamine has been recommended.

11 DESCRIPTION

MYDCOMBI is a sterile, clear, colorless fixed dose combination of an anticholinergic (tropicamide) and an alpha-adrenergic receptor agonist (phenylephrine hydrochloride) for topical ophthalmic use. The 2 active ingredients are represented by the chemical structures below.

Tropicamide:

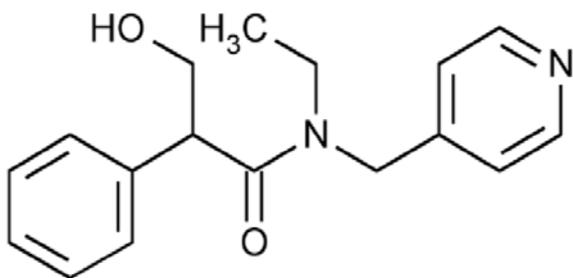

Chemical Name: Benzeneacetamide, N-ethyl- α -(hydroxymethyl)-N-(4-pyridinylmethyl)-

Molecular Formula: C₁₇H₂₀N₂O₂

Molecular Weight: 284.35 g/mol

Phenylephrine Hydrochloride:

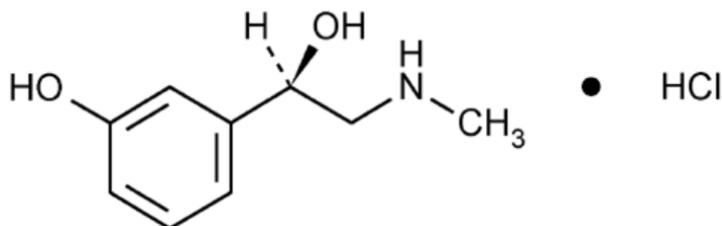

Chemical Name: (R)-3-hydroxy- α [(methylamino)methyl]benzenemethanol hydrochloride

Molecular Formula: C₉H₁₃NO₂•HCl

Molecular Weight: 203.67 g/mol

Each mL of MYDCOMBI ophthalmic spray (sterile) contains: **ACTIVES:** Phenylephrine Hydrochloride 2.5% (25 mg) equivalent to 20.6 mg of phenylephrine base, Tropicamide 1% (10 mg); **INACTIVE:** Hydrochloric Acid and/or Sodium Hydroxide may be added to adjust pH (pH 4.8–5.2), Water for Injection; **PRESERVATIVE:** Benzalkonium Chloride 0.01% (0.1 mg).

12 CLINICAL PHARMACOLOGY

12.1 Mechanism Of Action

Tropicamide, the anticholinergic component of MYDCOMBI, blocks the responses of the sphincter muscle of the iris, dilating the pupil (mydriasis). Phenylephrine hydrochloride, the alpha-1 adrenergic agonist component of MYDCOMBI, acts as a mydriatic agent by contracting the dilator muscle of the iris.

12.2 Pharmacodynamics

MYDCOMBI acts in 15 to 30 minutes with maximal mydriasis occurring in 20 to 90 minutes. Darker irides tend to dilate slower than lightly pigmented irides and to achieve maximal effect may require more doses than lighter irides.

Mydriasis will reverse spontaneously with time, with recovery after 3 to 8 hours. Complete recovery from mydriasis in some individuals may require 24 hours.

14 CLINICAL STUDIES

Two Phase 3 clinical trials were conducted to evaluate the efficacy of MYDCOMBI for achievement of mydriasis. The MIST-1 study was a prospective, double-masked, active-controlled, 3-period cross-over, superiority study to compare the pupil dilating effect of MYDCOMBI to tropicamide 1% and to phenylephrine 2.5%, with all solutions topically administered by the Optejet® Dispenser (N = 64 subjects; 128 eyes). The MIST-2 study was a prospective, multicenter, double-masked, placebo-controlled, 3-period crossover, superiority study to compare the pupil dilating effect of MYDCOMBI to placebo (eyewash solution), with both solutions topically administered by the Optejet Dispenser (N = 70 subjects; 140 eyes).

The primary efficacy endpoint for both studies was the mean change in 35-minute pupil diameter compared to baseline as measured by digital pupillometry in highly photopic conditions. Data from the 2 studies are presented in **Table 1** [Error! Reference source not found.](#) At 35 minutes post-dose, the mean change in pupil diameter was 4.7 mm with MYDCOMBI, 4.1 mm with tropicamide, and 0.9 mm with phenylephrine in MIST-1, and was 4.8 mm with MYDCOMBI and 0.1 mm with placebo in MIST-2. MYDCOMBI was statistically superior to tropicamide administered alone and phenylephrine administered alone.

Table 1 Pupil Size and Change in Diameter from Baseline at 35 Minutes Post-Dose (MIST-1 and MIST-2) (Per-Protocol Population ^[1])

Visit	MIST-1			MIST-2	
	MYDCOMBI (N = 124)	Tropicamide Alone (N = 124)	Phenylephrine Alone (N = 124)	MYDCOMBI (N = 138)	Placebo (N = 138)
Mean Baseline (SD)	2.6 (0.05)	2.6 (0.05)	2.6 (0.05)	2.6 (0.04)	2.6 (0.04)
35-Minutes Post-Dose (SD)	7.3 (0.08)	6.7 (0.08)	3.5 (0.08)	7.3 (0.07)	2.7 (0.05)
Change from Baseline (SD)	4.7 (0.07)	4.1 (0.06)	0.9 (0.08)	4.8 (0.07)	0.1 (0.04)
Difference from MYDCOMBI (95% CI) ^[2]	--	0.6 (0.4, 0.8)	3.9 (3.7, 4.1)	--	4.7 (4.5, 4.8)

SD=Standard Deviation

^[1] The per-protocol (PP) population included all randomized subjects who received at least one dose of study medication and completed all planned assessments (related to the primary endpoint) without major protocol violations. Two subjects in MIST-1 and one subject in MIST-2 who withdrew consent after their first treatment visit were not included in the PP populations which resulted in 62 completed subjects (124 eyes) in MIST-1 and 69 completed subjects (138 eyes) in MIST-2 comprised the PP populations. Sensitivity analysis performed on the intent-to-treat (ITT) population including all randomized subjects resulted in consistent efficacy results.

^[2] Treatment differences and 95% confidence interval estimates were based on a mixed model including treatment, eye, baseline diameter, and carryover effect (for MIST-2 study only). In both studies, an unstructured covariance structure was used to account for within-subject correlation between eyes.

MYDCOMBI provided a clinically significant effect in the proportion of eyes achieving pupil diameter of ≥ 6 mm at 35-minute post-dose in 94% of eyes compared to 78% of eyes administered tropicamide alone and 1.6% of eyes administered phenylephrine alone, and 0% of eyes administered placebo. As shown in [Figure 2](#), peak effect was measured at the 80-minute evaluation when the mean change from baseline was 5.2 mm. Treatment differences in mydriasis were observed as early as 20 minutes and still present at 180 minutes post-dose, the end of the protocol-specified observation period.

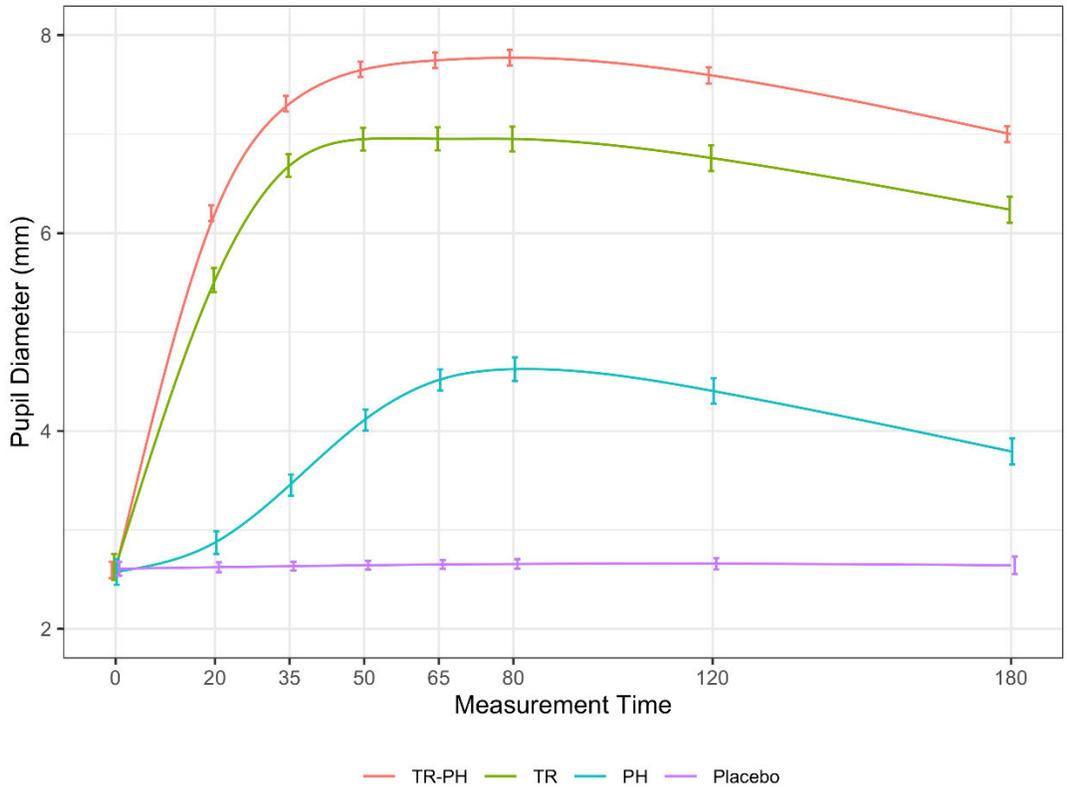

Figure 2: MIST-1 and MIST-2 pooled, mean pupil diameter vs measurement time, by treatment group. Vertical bars show 95% confidence interval for the mean at each point. Smooth curves are based on an 8 degrees of freedom (df) generalized additive model (GAM) smooth through time, adjusting for baseline pupil diameter. Confidence intervals are not adjusted for correlation.

16 HOW SUPPLIED/STORAGE AND HANDLING

MYDCOMBI is supplied as sterile, clear, colorless solution in a 2 mL vial enclosed in a dispenser cartridge. Each MYDCOMBI cartridge holds approximately 180 sprays.

Do not tamper with or attempt to open the MYDCOMBI cartridge. Such action may damage the dispenser causing an incorrect medication discharge volume; additionally, the dispenser base may not function properly.

Only use the MYDCOMBI cartridge with the MYDCOMBI Dispenser base which may be supplied separately. The MYDCOMBI base will not work with any other cartridges.

NDC 81046-0111-01. Carton containing one replacement sterile drug cartridge

NDC 81046-0111-02. Box containing one carton with one sterile drug cartridge, and one carton with one base unit

NDC 81046-0111-05. Box containing five cartons, each with one replacement sterile drug cartridge

The MYDCOMBI cartridge must be used prior to the expiration date on the cartridge.

Storage: Store at room temperature 15°C to 25°C (59°F to 77°F).

Manufactured for Eyenovia, Inc. by Alcami Corporation

17 PATIENT COUNSELING INFORMATION

Advise patients that they may experience sensitivity to light and blurred vision while their pupils are dilated.

Advise patients not to drive, use machinery, or do any activity that requires clear vision until they are sure they can perform such activities safely.

INSTRUCTIONS FOR USE

MydCombi™ (Tropicamide and Phenylephrine HCl Ophthalmic Spray), 1%/2.5%

Rx Only

Contents

Getting to know MydCombi™	3
How the MydCombi™ Dispenser Works	3
Understanding the Mist and Battery Lights	4
Important Reminders and Cleaning Instructions	4
Storing the MydCombi™ Base and Cartridges	5
Assembling the MydCombi™ Dispenser	6
Preparing MydCombi™ for Use Each Day	8
Administering MydCombi™	9
Troubleshooting Tips	10
Replacing the MydCombi™ Cartridge	10
Symbols Used in Labels on the MydCombi™ Cartridge, Base and Packaging	11

INSTRUCTIONS FOR USE MydCombi™ Ophthalmic Spray

This “Instructions for Use” document has information about the administration of MydCombi™ (Tropicamide and Phenylephrine HCl Ophthalmic Spray) 1%/2.5%.

MydCombi™ is packaged in a dispenser that mists drug solution onto the eye. It has 2 parts – the cartridge that holds the drug solution, and the base that holds electronics.

Getting to know MydCombi™

MydCombi™ Dispenser Parts

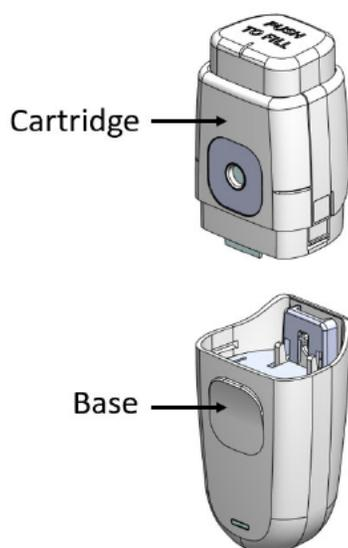

MydCombi™ Assembled

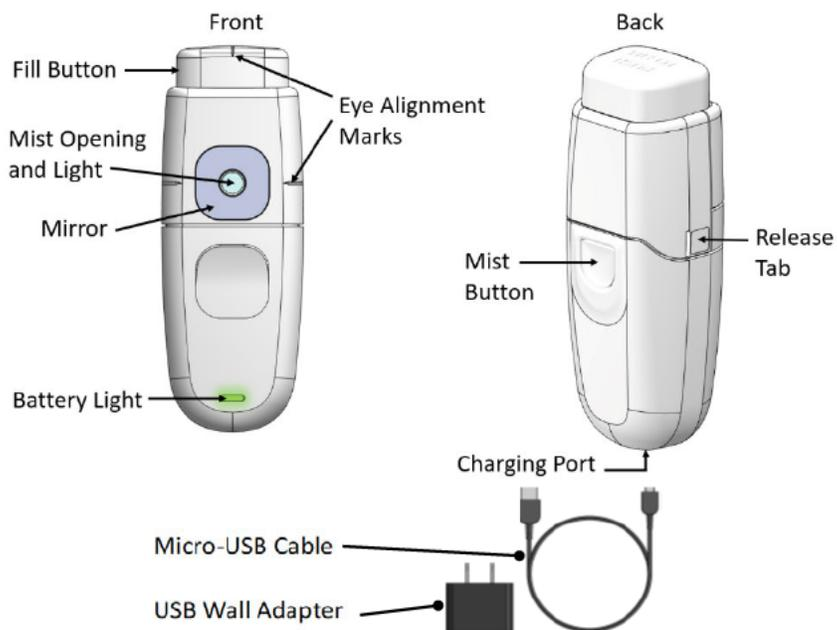

How the MydCombi™ Dispenser Works

- The **MydCombi™ Cartridge** holds the drug solution.
- The **MydCombi™ Base** supplies power to the dispenser.
- The **Fill Button** is pressed to load the drug solution for topical ophthalmic administration.
- The **Mist Opening** is where drug solution comes out when the **Mist Button** is pressed.
- The **Light and Mirror** around the **Mist Opening** and the **Eye Alignment Marks** on the top and each side of the cartridge help align the eye for drug administration.
- The **Battery Light** shows how much electrical charge remains in the **Base**.
- The **Release Tabs** on each side of the cartridge are used to separate the cartridge and base when replacing cartridges.
- The MydCombi™ Base is charged using a **Micro-USB to USB Cable with Wall Plug or USB port** (supplied separately). See “MydCombi™ Base Charging and Electrical Information” .

Understanding the Mist and Battery Lights

The **Mist Light** and the **Battery Light** show the status of the MydCombi™ dispenser.

What the Mist and Battery Lights Mean

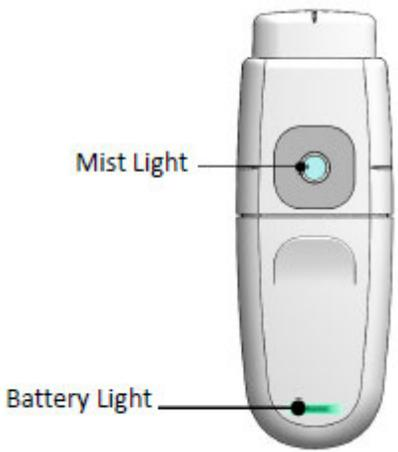
	If you see...	It means...
 <p>The diagram shows a vertical, grey dispenser. At the top, there is a circular area labeled 'Mist Light' containing a small blue light. At the bottom, there is a rectangular area labeled 'Battery Light' containing a small green light.</p>	Mist Light SOLID BLUE	Ready to dose
	Mist Light BLINKING BLUE with Battery Light BLINKING RED & BLUE	Reset the dispenser – See “ TROUBLESHOOTING TIPS ” (page 10) for dispenser reset instructions. <i>If lights continue blinking after dispenser reset, reset again. If lights continue to blink after second reset, change the cartridge.</i>
	Battery Light BLINKING GREEN	Battery is charging
	Battery Light SOLID GREEN	Battery is fully charged
	Battery Light BLINKING RED	Battery is low
	Battery Light SOLID RED	Charge dispenser base at once

Important Reminders and Cleaning Instructions

- Wash hands prior to using MydCombi™.
- Before each use, the exterior (including the mirror surface) of the dispenser should be cleaned using a 70% isopropyl alcohol (IPA) wipe or a clean dust-free, cotton cloth dampened with 70% IPA solution.
- Wipe the exterior for 3 minutes. While wiping, pay close attention to all cracks, crevices, and any other hard to reach areas. Additional wipes may be used as needed. Allow the exterior to air dry. Only manual, non-immersion cleaning as described should be used for the dispenser. Do not autoclave (steam sterilize) or immerse in cleaning fluids. Always disconnect power supply from source before cleaning.
- If the patient wears soft contact lenses, they should be removed at least 10 minutes before drug administration.
- If the patient uses artificial tears, they should not be administered within 10 minutes of drug administration.
- Each MydCombi™ cartridge holds approximately 180 sprays.
- Only use the MydCombi™ cartridge with the MydCombi™ base. The MydCombi™ base will not work with any other type of cartridges.
- See “MydCombi™ Base Charging and Electrical Information” contained with MydCombi™ for complete instruction on charging and applicable electrical information.

Storing the MydCombi™ Base and Cartridges

Store MydCombi™ bases and cartridges at room temperature 15°C to 25°C (59°F to 77°F). Protect from light and excessive heat.

- **Do not** heat or freeze the MydCombi™ base or cartridge.
- **Do not** expose MydCombi™ base to fluids.
- **Do not** tamper with or try to open the MydCombi™ cartridge or base. Doing so could cause damage and result in personal injury.

The MydCombi™ base contains a lithium-ion battery. Damage to the base can cause fire. Do not puncture base or expose to excessive heat ($\geq 50^{\circ}\text{C}$).

Li-Ion batteries may pose environmental and safety hazards and should be disposed of in accordance with all applicable Federal and State Laws. Check with all governing travel bodies for current requirements before air travel.

Assembling the MydCombi™ Dispenser

Complete these steps to assemble the MydCombi™ base and cartridge.

Note: If packaging is opened or damaged, do not use the contents. Instead, open a new base or cartridge, and contact your distributor for a replacement.

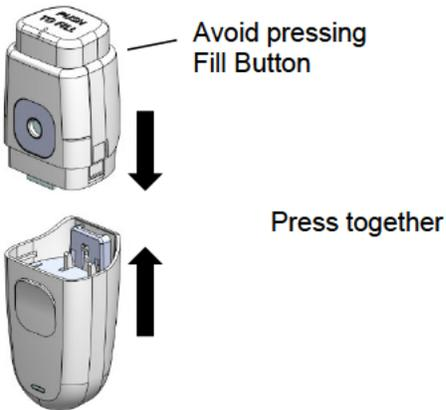

1. Assemble

- Remove base and/or cartridge from packaging.
- Align base and cartridge, then press together until they click.
 - Take care to avoid pressing Fill Button when assembling.

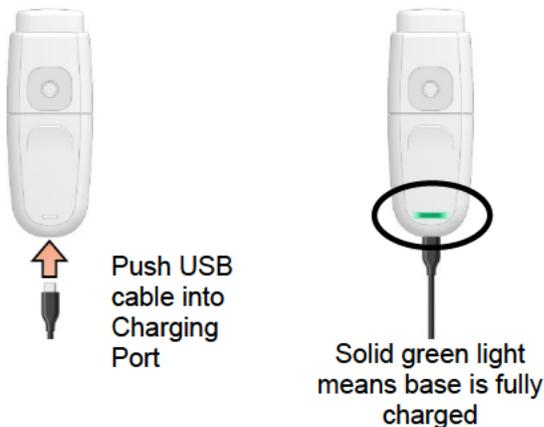

2. Charge

Charge MydCombi™ base before first use (see “MydCombi Base Charging and Electrical Information” contained with MydCombi™ base packaging). Charging may be performed either before or after assembly.

- Push micro-USB cable into Charging Port.
- Connect opposite end of USB cable to wall outlet plug or USB port.
 - Battery light **BLINKS GREEN** while charging.
- Charge until battery light turns **SOLID GREEN**, then disconnect cable from Charging Port.

Note: Excessive charging may damage battery or decrease battery life. Charging weekly, or when the Battery Light begins blinking red (signaling low battery) is recommended.

(continued)

Assembling the MydCombi Dispenser (continued)

Press Fill Button down until
light turns blue



Then, slowly release,
while counting to 3



3. Prime

- a. Hold MydCombi™ dispenser upright.
- b. Firmly press Fill Button down until it stops, and Mist Light turns Blue.
- c. Slowly release Fill Button, while counting to 3.
 - If Fill Button does not return to position, press again until it is all the way down.
 - If Fill Button still does not return to position, get a new cartridge, and re-assemble (**Steps 1 - 2** [page 6]).
- d. Point Mist Opening away from face.
- e. Firmly press, then release Mist Button.
- f. Repeat **Steps a – e** until mist emerges from opening.
 - If mist does not come out after repeating these steps 5 times, get a new cartridge and re-assemble (**Steps 1 - 2** [page 6]).

Press and release
Mist Button
(on back of base)

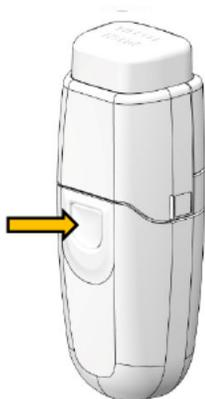

4. MydCombi™ is now ready to use.

Preparing MydCombi™ for Use Each Day

Important: A test mist must be performed each day before dosing is commenced.

Press Fill Button down until
light turns blue



Then, slowly release,
while counting to 3

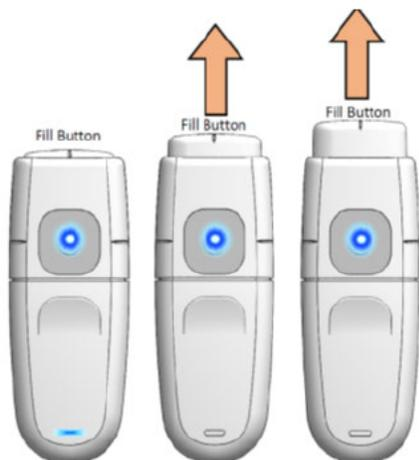

Press and release
Mist Button
(on back of base)

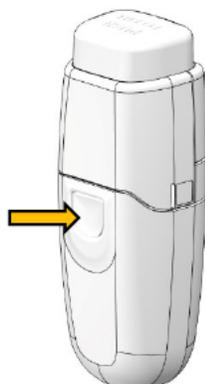

1. Load drug solution

- Hold MydCombi™ dispenser upright.
- Firmly press Fill Button down until it stops, and Mist Light turns Blue.
- Slowly release Fill Button, while counting to 3.
 - If Fill Button does not return to position, press again until it is all the way down.
 - If Fill Button still does not return to position, get a new cartridge, and re-assemble (**Steps 1 - 2** [page 6]).

2. Do a test mist

- Holding MydCombi™ dispenser upright, point Mist Opening away from face.
- Firmly press and release Mist Button.

3. MydCombi™ is ready to use.

Administering MydCombi™

Important: Keep MydCombi™ dispenser upright during use to maintain dose volume.

Press Fill Button down until light turns blue



Then, slowly release, while counting to 3



1. Load drug solution

- Hold MydCombi™ dispenser upright and firmly press Fill Button down until it stops, and Mist Light turns Blue.
- Slowly release Fill Button, while counting to 3.

2. Align MydCombi™ with patient's eye

- Hold MydCombi™ dispenser with thumb over Mist Button, wrapping other fingers around base.
- Bring MydCombi™ dispenser to patient's eye with Mirror facing the eye.
 - The dispenser should be as close as patient's nose.
 - To prevent blinking, use your other hand to gently pull lower eyelid down or ask patient to pull her/his lid down.
- Aim Mist Opening toward the center of eye.
- Confirm Alignment Marks (on the Fill Button and the cartridge side) align with the center of eye.
 - Ask patient to confirm when their eye is centered on the BLUE Mirror.

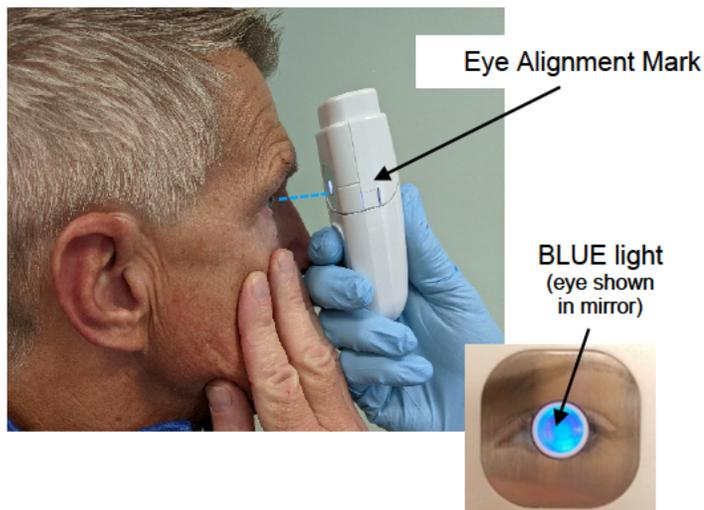

If patient is having trouble centering their eye on the blue light, ask that they look up, then look at the BLUE Mirror.

3. Press Mist Button

- Firmly press and release Mist Button.
 - The drug solution should gently wet the eye. Repeat Steps 1-3 if needed.

Press and release Mist Button (on back of base)

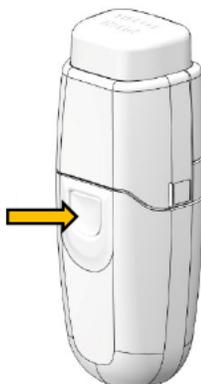

Troubleshooting Tips

1. If no mist comes out when Mist Button is pressed, confirm Fill Button has been pressed down completely, and has returned to the “up” position.
2. If solution is not administered within 1 minute after loading, it will be automatically discharged - the MIST Light will blink blue while the Battery Light blinks red and blue. The MydCombi™ dispenser must be reset using the steps below.

To reset dispenser:

- Press and release Mist Button.
- Press and release Fill Button.
- Press and release Mist Button again.
- Reload solution (Step 1 [page 9]).

To report suspected adverse reactions please contact Eyenovia, Inc at 1-833-393-6684 (Option 1) or FDA at 1-800-FDA-1088 or <http://www.fda.gov/medwatch>.

Replacing the MydCombi™ Cartridge

Squeeze Release Tabs
on each side

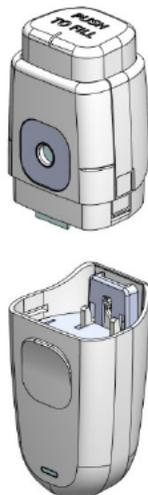
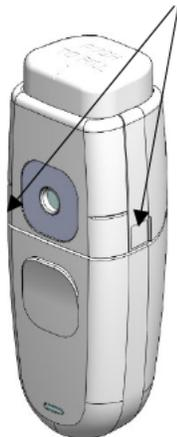

1. Remove cartridge

- a. Hold MydCombi™ base in one hand. With other hand, press and squeeze Release Tabs on each side of cartridge.
- b. Pull cartridge and base apart.
- c. Place used cartridge in original tray and box for disposal or recycling.

Symbols Used in Labels on the MydCombi™ Cartridge, Base and Packaging

SYMBOL	DEFINITION	SYMBOL	DEFINITION
	CAUTION, CONSULT ACCOMPANYING DOCUMENTS		USE BY (YYYY-MM: YEAR-MONTH)
	SEE INSTRUCTIONS FOR USE		STERILIZED USING ETHYLENE OXIDE
	CATALOG NUMBER		NON-STERILE
	BATCH CODE		DO NOT RESTERILIZE
	QUANTITY		LITHIUM-ION BATTERY - TO BE APPROPRIATELY RECYCLED
	DATE OF MANUFACTURE (YYYY-MM : YEAR-MONTH)		KEEP DRY
	MANUFACTURER		GHS LITHIUM-ION DISPOSAL
	DO NOT USE IF THE PACKAGING HAS BEEN OPENED OR DAMAGED		ELECTRONIC EQUIPMENT. DO NOT THROW IN TRASH.
	WARNING: ELECTRICITY		BY PRESCRIPTION ONLY
	PROTECTED AGAINST VERTICALLY FALLING WATER DROPS UP TO 15-DEGREE ANGLE		TYPE BF PART COMPLYING WITH IEC 60601-1



Manufactured By:

Eyenovia
295 Madison Ave., Suite 2400
New York, NY 10017

© 2022 Eyenovia, Inc. All rights reserved.

Mydcombi™ Base

Charging and Electrical Information

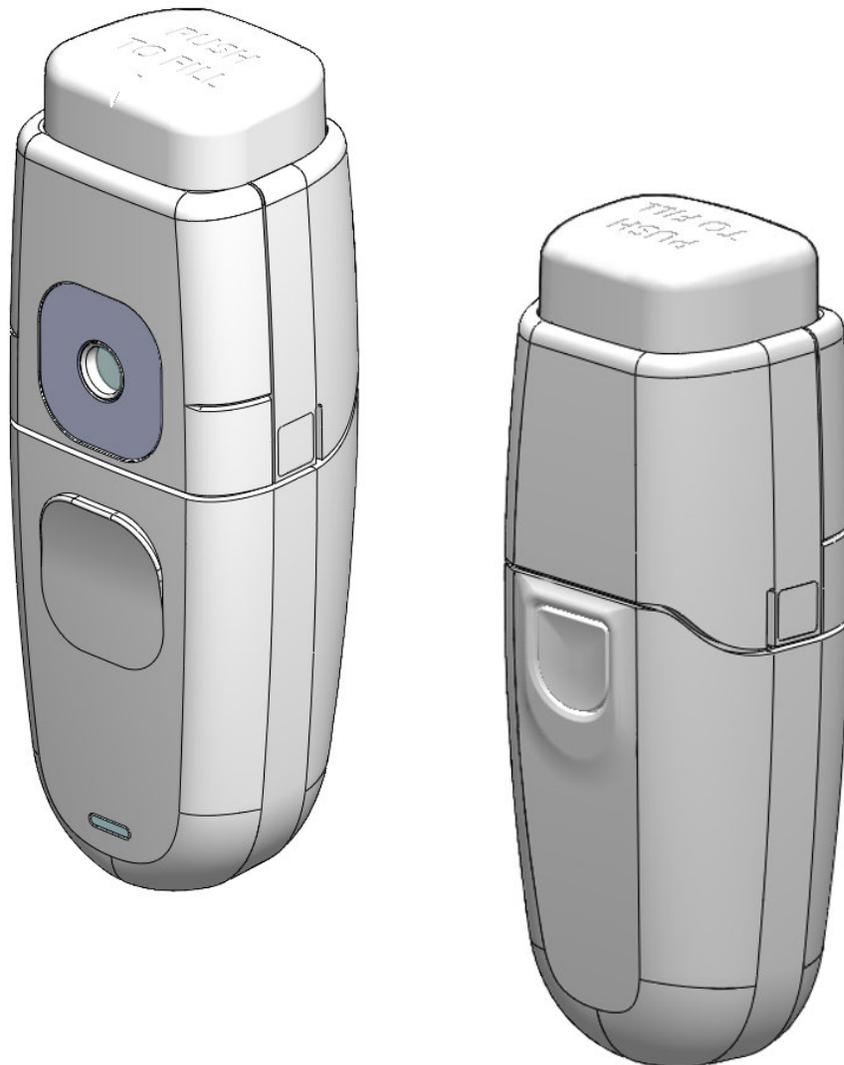

Table of Contents

1. Charging the Mydcombi™ Base	3
2. Specifications for Mydcombi Base and Charger	4
3. EMC	5
4. Disposal	7
5. Notes on Safety	7
6. Reporting to Manufacturer and Authorities	7
7. Symbols Used in Labels on Mydcombi™ Base and Packaging	8

1. CHARGING THE MYDCOMBI™ BASE

NOTE: Do not use base if packaging is opened or damaged. Get a new package by contacting your Eyenovia sales representative or calling 1-833-393-6684 (choose Option 1).

Type of Charger: Micro-USB to USB Cable with Wall Plug or USB port (see section 2 for specifications)

Charge Mydcombi™ Base Before First Use

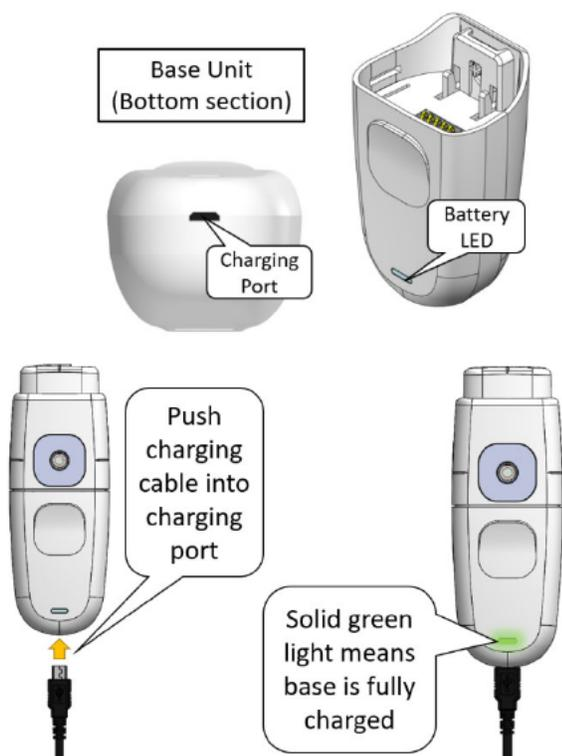

Charging may be performed either before or after assembly with Mydcombi™ cartridge.

Refer to “Instructions for Use - Mydcombi™ Ophthalmic Spray” for information on cartridge/base assembly and drug administration.

Perform the following steps to charge base:

1. Push micro-USB cable into charging port.
2. Connect opposite end of USB cable to wall outlet plug or USB port.
 - Battery light **BLINKS GREEN** while charging.
3. Charge until battery light turns **SOLID GREEN**, then disconnect cable from base.

Note: Excessive charging may damage battery or decrease battery life. Charging weekly, or when the LED light begins blinking red (signaling low battery), is recommended.

Battery Indicators on Mydcombi™ Base

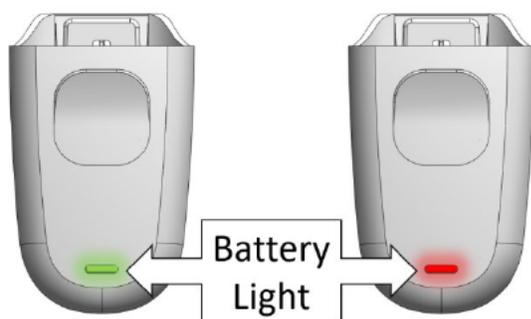

If Battery Light is...	It means...
BLINKING GREEN	Battery is charging
SOLID GREEN	Battery is fully charged
BLINKING RED	Battery is low
SOLID RED	Charge base at once

2. SPECIFICATIONS FOR MYDCOMBI BASE AND CHARGER

Base Specifications

Parameter	Specifications
Operating power	4.1VDC
Power source	Internally powered, Lithium-Ion Battery
Instrument make / model	Eyenovia / Mydcombi™ Base
Dimensions	50 length, 120mm height, 40mm width (When assembled with cartridge)
Weight (system)	< 100g (When assembled with cartridge)
Allowed operating temperature range	15°C to 25°C (59°F to 77°F)
Allowed shipping and storage temperature range	15°C to 25°C (59°F to 77°F) at relative humidity of 15% to 90% RH, non-condensing
Allowed operation, storage, and shipping humidity range	15°C to 25°C (59°F to 77°F) at relative humidity of 15% to 90% RH, non-condensing
Allowed operation, storage, and shipping atmospheric pressure	700hPa to 1060hPa
Electrical shock protection - Classification / Degree	Internally powered Class I
Battery life	2-4 weeks, if used as indicated.
Use Life	Do not use base longer than 12 months from date of first use, or after Use By Date
Software version	Software version number can be obtained by calling the manufacturer.

Charger Specifications (Micro-USB to USB Cable with Wall Plug or USB port)

Parameter	Specifications
Type	Switching Power Supply
Input	100-240V~, 50/60 Hz 200mA
Output	5V, 1A
USB Cable Minimum Requirements	5V, 1A
<p>USB cable must be UL Listed. Must meet US Standard Level VI energy efficiency. Must meet DOE & CEC regulatory requirements.</p> <p>Examples of acceptable cables include those with UL number E178074 or Homespot Model S005AYU0500100.</p>	

Charging and Electrical Information
Mydcombi™ Base

3. EMC

This device has been tested and found to comply with the limits for a Class B digital device, pursuant to part 15 of the FCC Rules. These limits are designed to provide reasonable protection against harmful interference in professional medical equipment. This equipment generates, uses, and radiates radio frequency energy and, if not prepared and used in accordance with instructions, may cause harmful interference to radio communications. There is no guarantee, however, that interference will not occur in a particular setting. If this device does cause harmful interference to radio or television reception, which can be determined by turning the device off/on, the user is encouraged to try to correct the interference by one or more of the following measures:

- Reorient or relocate the receiving antenna
- Increase the separation between the device and receiver
- Connect the device into an outlet on a circuit different from that to which the receiver is connected
- Consult the dealer or an experienced radio/TV technician for help

Note: Changes or modifications not expressly approved by the party responsible for compliance could void the user's authority to operate the device.

Guidance and Manufacturer's Declaration

This device is intended for use in the electromagnetic environment specified below. The device user should assure use in such an environment.

Electromagnetic emissions		
Emissions Test	Compliance	
RF emissions CISPR 11	Group 1	
RF emissions CISPR 11	Class B	
Harmonic Emissions IEC 61000-3-2	Class B	
Voltage Fluctuations/Flicker emissions IEC 61000-3-3	Complies	
Electromagnetic immunity		
Phenomena of a continuous nature	Shall operate as intended. Shall be no degradation of performance. Shall be no loss of function.	
Phenomena of transient nature	Functions shall be self-recoverable. Shall operate as intended after recovering. Shall be no degradation of performance,	
Power interruption exceeding a certain time	Functions shall be recoverable by the operator. Shall operate as intended after recovering. Shall be no degradation of performance.	
Immunity Test	IEC 60601 Test Level	Compliance Level
Electrostatic fast transient/burst IEC 61000-4-4 (Charging Only)	±2 kV for power supply lines	±2 kV for power supply lines
Surge IEC 61000-4-5 EN/IEC 61000-4-3 L-N (Charging Only)	±1 kV differential mode	±1 kV differential mode
EN/IEC 61000-4-3 (Charging Only)	Radiated Immunity 3 V/m, 80 – 2700 MHz 80% AM at 1 kHz & Proximity Fields from RF Wireless Communications Equipment	Radiated Immunity 3 V/m, 80 – 2700 MHz 80% AM at 1 kHz & Proximity Fields from RF Wireless Communications Equipment
Voltage dips, short interruptions, and voltage variations on power supply input lines IEC 61000-4-11	Voltage Dips 30% reduction, 25/30 periods At 0°	Voltage Dips 30% reduction, 25/30 periods At 0°
	Voltage Dips > 95% reduction, 0.5 period At 0°, 45°, 90°, 135°, 180°, 225°, 270°, and 315°	Voltage Dips > 95% reduction, 0.5 period At 0°, 45°, 90°, 135°, 180°, 225°, 270°, and 315°
	Voltage Dips > 95% reduction, 1 period At 0°	Voltage Dips > 95% reduction, 1 period At 0°
	Voltage Interruptions > 95% reduction, 250/300 periods	Voltage Interruptions > 95% reduction, 250/300 periods
Conducted RF EN/IEC 61000-4-6	Continuous Conducted RF, 80% AM (1 kHz) 3 Vrms, 0.15-80 MHz 6 Vrms in ISM and amateur radio Bands within 150kHz – 80MHz	Continuous Conducted RF, 80% AM (1 kHz) 3 Vrms, 0.15-80 MHz 6 Vrms in ISM and amateur radio Bands within 150kHz – 80MHz
Magnetic field IEC 61000-4-8	Power Frequency Magnetic Field 30Arms/m at 50/60Hz	Power Frequency Magnetic Field 30Arms/m at 50/60Hz

Charging and Electrical Information
Mydcombi™ Base

Immunity to RF Wireless Communications Equipment						
Test Frequency (MHz)	Band ^{a)} (MHz)	Service ^{a)}	Modulation ^{b)}	Max. Power (W)	Distance (m)	Immunity test level (V/m)
385	380 – 390	TETRA 400	Pulse ^{b)} 18 Hz	1.8	0.3	27
450	430 – 470	GMRS 460, FRS 460	FM ^{c)} ± 5 kHz Deviation 1 kHz sine	2	0.3	28
710	704 – 787	LTE Band 13, 17	Pulse ^{b)} 217 Hz	0.2	0.3	9
745						
780						
810	800 – 960	GSM 800/900, TETRA 800, iDEN 820, CDMA 850, LTE Band 5	Pulse ^{b)} 18 Hz	2	0.3	28
870						
930						
1720	1 700 – 1 990	GSM 1800; CDMA 1900; GSM 1900; DECT; LTE Band 1, 3, 4, 25; UMTS	Pulse ^{b)} 217 Hz	2	0.3	28
1845						
1970						
2450	2 400 – 2 570	Bluetooth, WLAN, 802.11 b/g/n, RFID 2450, LTE Band 7	Pulse ^{b)} 217 Hz	2	0.3	28
5240	5 100 – 5 800	WLAN 802.11 a/n	Pulse ^{b)} 217 Hz	0.2	0.3	9
5500						
5785						

a) For some services, only uplink frequencies are included.
b) The carrier shall be modulated using a 50% duty cycle square wave signal.
c) As an alternative to FM modulation, 50% pulse modulation at 18 Hz may be used because, while it does not represent actual modulation, it would be worst case.

Recommended separation distances between portable and mobile RF communications equipment and the device, except for the distances indicated in the following table “Immunity to RF Wireless Communications Equipment”.			
The device is intended for use in an electromagnetic environment in which radiated RF disturbances are controlled. Users can help prevent electromagnetic interference by maintaining a minimum distance between portable and mobile RF communications equipment (transmitters) and the device as recommended below, according to the maximum output power of the communications equipment.			
Rated maximum output power of transmitter (W)	Separation distance according to frequency of transmitter (m)		
	150 kHz to 80 MHz $d = 1.2\sqrt{P}$	80 MHz to 800 MHz $d = 1.2\sqrt{P}$	800 MHz to 2.7 GHz $d = 2.3\sqrt{P}$
0.01	0.12	0.12	0.23
0.1	0.38	0.38	0.73
1	1.2	1.2	2.3
10	3.8	3.8	7.3
100	12	12	23
For transmitters rated at a maximum output power not listed above, the recommended separation distance d in meters (m) can be estimated using the equation applicable to the frequency of the transmitter, where P is the maximum output power rating of the transmitter in watts (W) according to the transmitter manufacturer.			
NOTE: At 80 MHz and 800 MHz, the separation distance for the higher frequency range applies.			
NOTE: These guidelines may not apply in all situations. Electromagnetic propagation is affected by absorption and reflection from structures, objects, and people.			

4. DISPOSAL

- **Contains Lithium-Ion Battery**
Lithium-Ion batteries may pose environmental and safety hazards and should be disposed of in accordance with all applicable Federal and State laws.
- **Electronic Equipment**
Base should be properly disposed of in accordance with all applicable State and Federal laws.

5. NOTES ON SAFETY

Warnings and Recommendations

- **Contains Lithium-Ion Battery**
Damage can cause fire. Do not puncture. Do not expose to excessive heat ($\geq 50^{\circ}\text{C}$).
- **Do not use after expiration date**
Expiration date is published on base label. Discontinue use if expiration date has passed.
- **Inspect for device damage**
Do not use if package has been opened or damaged or if there is evidence of base damage. Doing so could result in injury.
- **Tampering with parts in the Mydcombi™ Base**
Do not tamper with or attempt to open the base. Doing so could cause damage and result in personal injury.
- **Risk of usage**
Failure to use base in accordance with instructions could affect dose dispensation. Keep base in upright position during use. If base has been idling for an extended period, dispense a waste spray. _Optejet will not dispense drug while the base is actively charging.
- **Risk due to insufficient user training**
Use base only with Mydcombi™ Cartridge. Refer to “Instructions for Use - Mydcombi™ Ophthalmic Spray”.
- **Risk due to battery leakage**
Do not use base if there is any sign of battery leakage.
- **Keep dry**
Do not expose base to fluids; keep dry.
- **Transportation and Storage**
Do not store or transport base with sharp or metallic objects.
- **Risk of electrical leakage**
Non-hazardous voltage is present during normal use.
- **Do not use with other equipment**
- **Do not use with non-certified USB charger**
Recharge base using a micro-USB cable (not included). Use of a charger other than that specified in **Section 2 - Specifications** could result in increased electromagnetic emissions or decreased electromagnetic immunity of the base, resulting in improper operation.

CAUTION – For professional use

Federal law restricts this device to sale by or on the order of a physician (21 CFR§801.109(b)(1)).

CAUTION – Radiation emission

This device emits electromagnetic radiation.

6. REPORTING TO MANUFACTURER AND AUTHORITIES

If a serious incident occurs in connection with this device that affects the user or another person, please report incident to Eyenovia by calling 1-833-393-6684 (choose Option 1) or FDA at 1-800-FDA-1088 or <http://www.fda.gov/medwatch>.

7. SYMBOLS USED IN LABELS ON MYDCOMBI™ BASE AND PACKAGING

SYMBOL	DEFINITION	SYMBOL	DEFINITION
	CAUTION, CONSULT ACCOMPANYING DOCUMENTS		USE BY (YYYY-MM: YEAR-MONTH)
	SEE INSTRUCTIONS FOR USE		ELECTRONIC EQUIPMENT. DO NOT THROW IN TRASH.
	CATALOG NUMBER		NON-STERILE
	BATCH CODE		KEEP DRY
	QUANTITY		LITHIUM-ION BATTERY - TO BE APPROPRIATELY RECYCLED
	DATE OF MANUFACTURE (YYYY-MM : YEAR-MONTH)		MANUFACTURER
	WARNING: ELECTRICITY		CAUTION: FEDERAL LAW RESTRICTS THIS PRODUCT
	PROTECTED AGAINST VERTICALLY FALLING WATER DROPS UP TO 15-DEGREE ANGLE		TYPE BF PART COMPLYING WITH IEC 60601-1

MANUFACTURED BY	Contact / Return Goods Policy
Eyenovia, Inc. 8748 Technology Way, Reno, NV 89521 © 2022 Eyenovia, Inc. All rights reserved. www.eyenovia.com	Contact your sales representative or Eyenovia for product returns. Call 1-833-EYENOVIA (393-6684) admin@eyenovia.com

MydCombi Bulk Replacement Cartridge Box

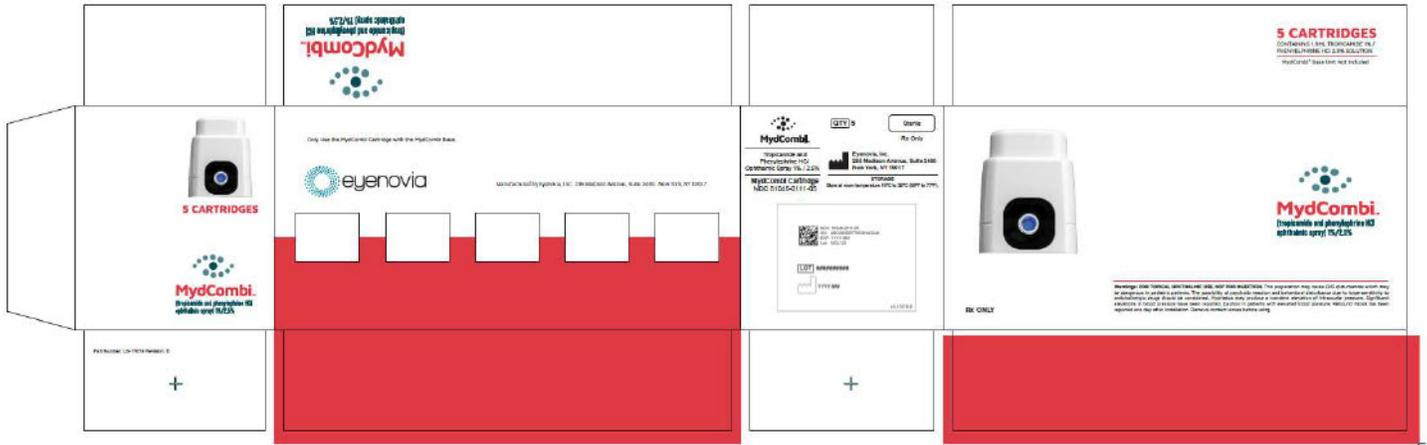

MydCombi Label Cartridge

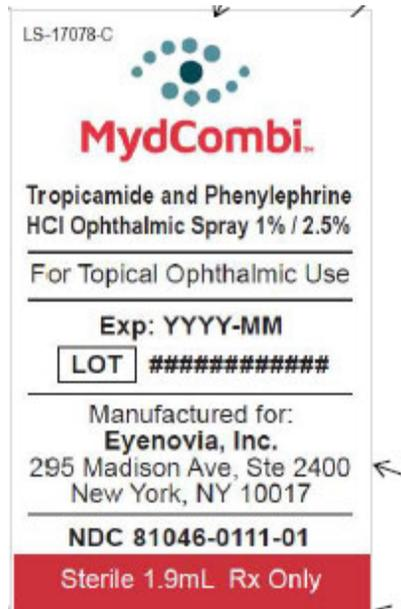

Scale - 2:1

MydCombi 2-Pack Box

Rx ONLY LS-17081-C

MydCombi. NDC 81046-0111-02

Tropicamide and Phenylephrine HCl Ophthalmic Spray 1% / 2.5%

MydCombi Cartridge

STORAGE
Store at room temperature 15°C to 25°C (59°F to 77°F). QTY 1

BASE UNIT

REF FG-16427 MydCombi Base QTY 1

STORAGE
Store at room temperature 15°C to 25°C (59°F to 77°F).

 **Eyenvia, Inc.**
295 Madison Avenue, Suite 2400
New York, NY 10017

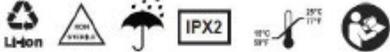

	<p>1 CARTRIDGE <small>CONTAINING 1 ML TROPICAMIDE 1% / PHENYLEPHRINE 2.5% HCl SOLUTION</small></p> <p>Store at room temperature 15°C to 25°C (59°F to 77°F)</p> <p>1 BASE UNIT</p>		<p style="transform: rotate(180deg);">MydCombi. <small>(tropicamide and phenylephrine HCl ophthalmic spray) 1% / 2.5%</small></p> 
<p>Rx ONLY LS-17081-C</p> <p style="text-align: center;"> MydCombi. NDC 81046-0111-02</p> <p style="text-align: center;">Tropicamide and Phenylephrine HCl Ophthalmic Spray 1% / 2.5%</p> <p>MydCombi Cartridge</p> <p>STORAGE Store at room temperature 15°C to 25°C (59°F to 77°F). QTY 1</p> <hr/> <p>BASE UNIT</p> <p>REF FG-16427 MydCombi Base QTY 1</p> <p>STORAGE Store at room temperature 15°C to 25°C (59°F to 77°F).</p> <p style="text-align: center;"> Eyenvia, Inc. 295 Madison Avenue, Suite 2400 New York, NY 10017</p> <p style="text-align: center;"></p>	 <p style="text-align: center;"> MydCombi. <small>(tropicamide and phenylephrine HCl ophthalmic spray) 1% / 2.5%</small></p> <p>1 CARTRIDGE <small>CONTAINING 1 ML TROPICAMIDE 1% / PHENYLEPHRINE HCl 2.5% SOLUTION</small></p> <p>1 BASE UNIT</p> <p><small>Recommended dosage. See Prescribing Information. Only use the MydCombi Cartridge with the MydCombi Base.</small></p>	 <p style="text-align: center;"> MydCombi. <small>(tropicamide and phenylephrine HCl ophthalmic spray) 1% / 2.5%</small></p>	 <p style="text-align: center;"><small>Warnings: FOR TOPICAL OPHTHALMIC USE. NOT FOR INJECTION. This preparation may cause OEG disturbance which may be dangerous in pediatric patients. The possibility of systemic reaction and behavioral disturbance due to hyperemmetropia in amblyopic eye should be considered. Monitor the patient for onset of muscular weakness. Significant weakness in these areas has been reported. Caution in patients with a known class of muscle. Reduced muscle has been reported only after intubation. Refer to package insert before using.</small></p>
			<p>LS-17081-C</p>

MydCombi Refill Cartridge Single Carton

Warnings: FOR TOPICAL OPHTHALMIC USE. NOT FOR INJECTION. This preparation may cause CNS disturbances which may be dangerous in pediatric patients. The possibility of psychotic reaction and behavioral disturbance due to hypersensitivity to anticholinergic drugs should be considered. Mydriatics may produce a transient elevation of intraocular pressure. Significant elevations in blood pressure have been reported. Caution in patients with elevated blood pressure. Rebound miosis has been reported one day after installation. Remove contact lenses before using.



NDC: 81046-0111-01
SN: ABC098DEF765GHI432JK
EXP: YYYY-MM
Lot: MCL123



Sterile
Rx Only

Tropicamide and Phenylephrine HCl
Ophthalmic Spray 1% / 2.5%

MydCombi Cartridge
NDC 81046-0111-01

LOT ##### **QTY** 1

YYYY-MM

Eyenovia, Inc.
295 Madison Avenue, Suite 2400
New York, NY 10017

STORAGE
Store at room temperature 15°C to 25°C (59°F to 77°F).

LS-17077-D



4.75" wide x 3.5" tall label
Does not print on carton
(Pink line does not print)

MydCombi. 1 CARTRIDGE
CONTAINS 0.1ML TROPICAMIDE 1% / PHENYLEPHRINE HCL 2.5% SOLUTION

MydCombi. 1 CARTRIDGE
CONTAINS 0.1ML TROPICAMIDE 1% / PHENYLEPHRINE HCL 2.5% SOLUTION

MydCombi. 1 CARTRIDGE
CONTAINS 0.1ML TROPICAMIDE 1% / PHENYLEPHRINE HCL 2.5% SOLUTION

MydCombi. 1 CARTRIDGE
CONTAINS 0.1ML TROPICAMIDE 1% / PHENYLEPHRINE HCL 2.5% SOLUTION

Warnings: FOR TOPICAL OPHTHALMIC USE. NOT FOR INJECTION. This preparation may cause CNS disturbances which may be dangerous in pediatric patients. The possibility of psychotic reaction and behavioral disturbance due to hypersensitivity to anticholinergic drugs should be considered. Mydriatics may produce a transient elevation of intraocular pressure. Significant elevations in blood pressure have been reported. Caution in patients with elevated blood pressure. Rebound miosis has been reported one day after installation. Remove contact lenses before using.



NDC: 81046-0111-01
SN: ABC098DEF765GHI432JK
EXP: YYYY-MM
Lot: MCL123

MydCombi. **Sterile**
Rx Only

Tropicamide and Phenylephrine HCl
Ophthalmic Spray 1% / 2.5%

MydCombi Cartridge
NDC 81046-0111-01

LOT ##### **QTY** 1

YYYY-MM

Eyenovia, Inc.
295 Madison Avenue, Suite 2400
New York, NY 10017

STORAGE
Store at room temperature 15°C to 25°C (59°F to 77°F).

LS-17077-D

C3995A

Part Number LS-17077
Revised: 0

MydCombi Commercial Base

MydCombi™ Base **Non-Sterile**

REF FG-16427  

LOT F-#####  

 YYYY-MM-DD **Li-ion** 

 **IPX2** 

Eyenovia, Inc.
295 Madison Ave, Ste 2400
New York, NY 10017

 (01) 00860009909700 **Rx ONLY**
(10) F-123456 **LS-17076-E**
(17) 250405

Scale – 2:1

MydCombi Commercial Base Single Carton

 **Rx ONLY**
LS-17075-D

REF FG-16427 MydCombi™ Base

LOT F-#####

QTY 1

 **USE BY** YYYY-MM-DD

 YYYY-MM-DD

 Eyenovia, Inc.
295 Madison Avenue, Suite 2400
New York, NY 10017

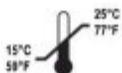

(01) 00860009909700
(10) F-123456
(17) 250405

   **IPX2**  

MydCombi Commercial Base Single Carton (cont'd)

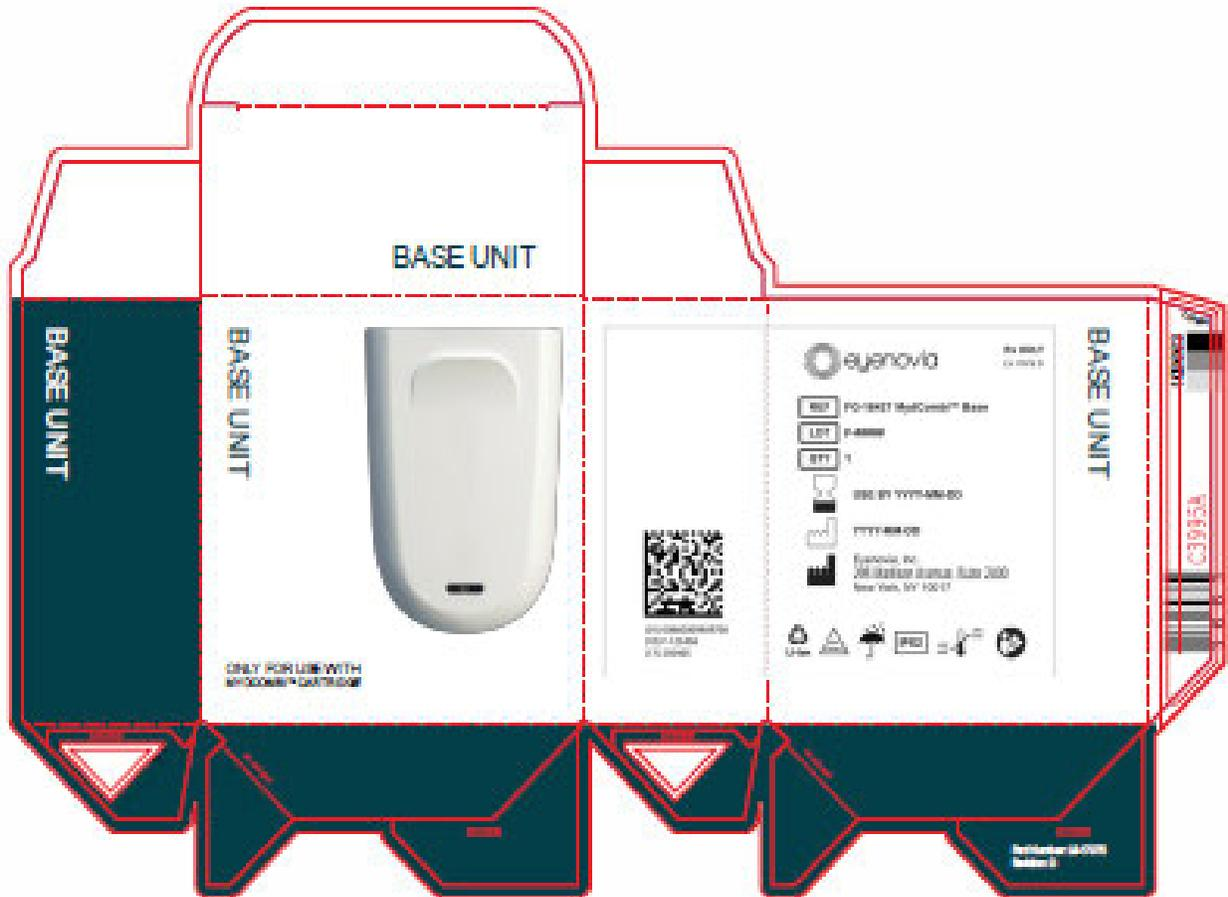

This is a representation of an electronic record that was signed electronically. Following this are manifestations of any and all electronic signatures for this electronic record.

/s/

WILEY A CHAMBERS
05/05/2023 03:56:17 PM